

Laboratorio di MECCANICA

GRU E MEZZI ELEVATORI

Costruzioni da 1 a 20

- 1 - Gru con carrucola fissa
- 2 - Gru con carrucola mobile
- 3 - Gru per riprese cinematografiche
- 4 - Gru a bandiera
- 5 - Piattaforma semovente verticale
- 6 - Gru con argano centrale
- 7 - Gru a cavalletto su ruote
- 8 - Gru mobile cabinata
- 9 - Cestello elevatore
- 10 - Gru su autocarro
- 11 - Transpallet
- 12 - Gru a portale
- 13 - Carrello elevatore con forche
- 14 - Carrello elevatore con pinza per fusti
- 15 - Ascensore da cantiere
- 16 - Torre della gru
- 17 - Gru tradizionale
- 18 - Gru con braccio a volata variabile
- 19 - Autogru
- 20 - Costruisci un ingranaggio a cremagliera



AVVISO

Per garantire un adeguato funzionamento del motore elettrico, durante la produzione è stata aggiunta una piccola quantità di grasso. In presenza di temperature elevate tale sostanza può sciogliersi divenendo untuosa. Nel caso in cui il motore contenuto nel kit sia sporco, puoi semplicemente pulirlo con delle salviette. Il grasso utilizzato non è né tossico, né pericoloso.

ATTENZIONE!

Solo per bambini di 8 anni e oltre. Le istruzioni per gli adulti sono incluse e devono essere rispettate.



Assistenza clienti
Tel. 02.82.52.52
Email - assistenza@clementoni.it

Manuale da leggere e conservare per future referenze.

Clementoni S.p.A.

Zona Industriale Fontenoce s.n.c.

62019 Recanati (MC) Italy

Tel.: +39 071 75811 - Fax: +39 071 7581234

www.clementoni.com

ISTRUZIONI PER GLI ADULTI CHE SURVEGLIANO: questo gioco è adatto ai bambini dagli 8 anni in su. Per il montaggio dello strumento e durante la manipolazione ed installazione degli elementi elettrici si raccomanda la presenza di un adulto.

RIMOZIONE E INSTALLAZIONE DELLE BATTERIE

Assicuratevi che l'apparecchio sia spento.

- 1 Utilizzate un cacciavite universale per svitare la vite che fissa il coperchio del vano batterie.
- 2 Rimuovete le batterie esaurite.
- 3 Inserite (4 x 1,5V AA/LR6) secondo il segno di polarità indicato nel vano stesso.
- 4 Le batterie devono essere inserite da un adulto.
- 5 Richiudete il coperchio del vano, stringendo la vite.
- 6 Assicuratevi che l'apparecchio funzioni.

COME INSERIRE LE BATTERIE

Chiedi aiuto ad un adulto!

Alimentazione: d.c. 6V

Batterie: 4 x 1,5V AA/LR6

Le batterie non sono incluse.

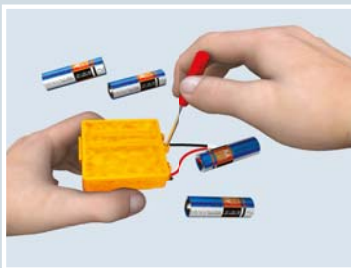

ALTRE RACCOMANDAZIONI:

- Le batterie sono pericolose se inghiottite, quindi tenerle lontano dalla portata dei bambini.
- Rimuovere le batterie qualora il gioco non venga utilizzato per un lungo periodo.
- Non tentare di aprire le batterie.
- Non gettare le batterie nel fuoco.

INDICAZIONI PER IL CORRETTO UTILIZZO DEI GIOCHI CON BATTERIE SOSTITUIBILI

ATTENZIONE!

- Le batterie devono essere inserite rispettando la corretta polarità + e - contrassegnata sulle batterie stesse.
- Le batterie scariche devono essere rimosse dal gioco.
- I morsetti di alimentazione non devono essere cortocircuitati.
- Non toccate in alcun modo i contatti all'interno del vano batterie per evitare possibili corto-circuiti.
- Le batterie ricaricabili vanno rimosse prima di essere ricaricate, effettuare la ricarica solo sotto la supervisione di un adulto.
- Le batterie non ricaricabili non devono essere ricaricate.
- Diversi tipi di batterie o batterie nuove e usate non devono essere mischiate.

COME SMALTIRE LE BATTERIE:

- Prima di gettare le batterie, scaricarle completamente attivando l'apparecchio fino al completo esaurimento delle stesse.
- Rimuovere le batterie dall'apparecchio prima dello smaltimento.
- Smaltire le batterie in conformità alle normative vigenti conferendole negli appositi contenitori laddove disponibili o presso un centro di raccolta autorizzato o presso il punto vendita dove è stato effettuato l'acquisto. La restituzione è gratuita!
- Sono previste sanzioni in caso di smaltimento abusivo.

ISTRUZIONI PER LO SMALTIMENTO DELLE BATTERIE



Il simbolo indica che le batterie esauste devono essere trattate in rispetto delle normative ambientali in vigore. I simboli chimici relativi a mercurio (Hg), cadmio (Cd) e/o piombo (Pb) che compaiono sotto il simbolo del bidone barrato indicano la presenza nella batteria di una significativa percentuale della sostanza indicata. Tali sostanze sono altamente dannose per l'ambiente e per la salute umana. Il corretto smaltimento delle batterie permette l'isolamento e il trattamento mirato delle sostanze nocive e consente il riciclaggio delle materie prime pregiate diminuendo gli effetti negativi sulle persone e sull'ambiente. Gettare le pile esauste in discarica o nell'ambiente aumenta notevolmente il rischio di inquinamento delle acque.

Ai sensi della Direttiva Europea 2013/56/UE è vietato smaltire pile e accumulatori come rifiuti urbani ed è fatto obbligo ai consumatori di partecipare alla raccolta differenziata in modo da agevolare il trattamento e il riciclaggio degli stessi.

ISTRUZIONI PER LO SMALTIMENTO DI APPARECCHIATURE ELETTRICHE ED ELETTRONICHE SOGGETTE A RACCOLTA DIFFERENZIATA

IMPORTANTE! Il simbolo del bidone  barrato indica che nei paesi dell'Unione Europea (Dir.2012/19/UE) ed in quelli che adottano sistemi di raccolta differenziata tutti i componenti del prodotto contrassegnati da questo simbolo (o in tal modo indicati nelle istruzioni del gioco) sono soggetti all'obbligo di raccolta differenziata alla fine del loro ciclo di vita. È vietato smaltire tali componenti come rifiuti urbani misti.

COME SMALTIRE LE AEE:

- È obbligatorio raccogliere separatamente solo i componenti contrassegnati con il simbolo  (o indicate nella documentazione come soggette) e conferirli agli appositi centri di raccolta allo scopo istituiti o, ove consentito, restituire il prodotto di cui ci si vuole disfare al proprio negoziante all'atto dell'acquisto di un prodotto analogo o a titolo gratuito nel caso in cui le dimensioni esterne del componente siano inferiori ai 25 cm.
- Gli utilizzatori del prodotto svolgono un ruolo determinante per favorire il corretto smaltimento delle apparecchiature elettriche ed elettroniche giunte a fine vita. È pertanto importante che ciascun utilizzatore sia consapevole del proprio ruolo e smaltisca sempre i rifiuti elettrici/elettronici nel rispetto della normativa vigente, contribuendo in questo modo ad una loro corretta gestione e favorendo il loro riutilizzo, riciclaggio e/o recupero.

ATTENZIONE!

- i componenti contrassegnati con il simbolo  contengono sostanze nocive per l'ambiente e la salute umana pertanto è vietato smaltirli come rifiuto urbano indifferenziato o con gli altri rifiuti domestici. Uno smaltimento non corretto può comportare danni per l'ambiente ed è sanzionato a termini di legge.
- È vietato utilizzare tali componenti in maniera impropria ed in particolare è vietato smontare le componenti elettriche ed elettroniche del gioco ed utilizzarlo se danneggiato. Tali comportamenti potrebbero provocare danni alla salute.

N.B.: Quanto sopra riportato riguarda esclusivamente le componenti del gioco contrassegnate (o indicate nella documentazione come soggette) con il simbolo .

Gli altri componenti del gioco (schede, accessori ecc.) e la confezione non sono soggetti alle indicazioni sopra riportate e devono essere smaltiti secondo le modalità previste dalle norme vigenti. Tali altri componenti non devono essere conferiti ai centri di raccolta delle apparecchiature elettriche ed elettroniche o restituiti al rivenditore all'atto dell'acquisto di un nuovo prodotto.

Gli utenti domestici (non professionali) sono invitati a contattare il proprio rivenditore, gli uffici pubblici preposti allo smaltimento dei rifiuti o il Servizio Clienti della: **CLEMENTONI S.p.A. (Tel. +39 071 75811; fax +39 071 7581234; e-mail: info@clementoni.it)** per tutte le informazioni inerenti il corretto smaltimento del prodotto.

 Iscrizione Registro produttori apparecchiature elettriche o elettroniche n° IT0801000000019 del 10/01/2008

AVVERTENZE

AVVERTENZA: Per distaccare correttamente i componenti dal supporto occorre ruotare su se stesso, manualmente, ogni piccolo elemento invece che strapparli.

N.B.: far eseguire da un adulto la rimozione dei pezzi dai supporti in plastica. Eventuali residui pungenti devono essere smaltiti prontamente.

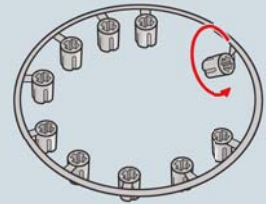

Assembla il giunto cardanico come indicato nelle figure.

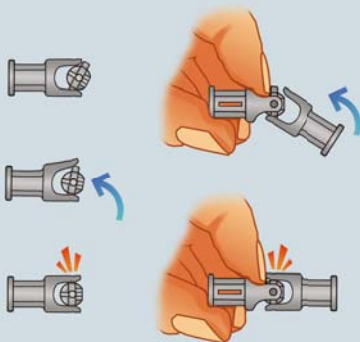

SIGNIFICATO DEI SIMBOLI:



Significa: Ruotare il modello



Significa: I pezzi sono stati serrati

ELENCO DEI PEZZI

	Barra doppia 15 fori	pz. 6		Anello corto	pz. 12		Ruota 10 denti	pz. 2
	Barra doppia 11 fori	pz. 6		Anello lungo	pz. 12		Ruota 18 denti	pz. 5
	Barra doppia 9 fori	pz. 6		Vite senza fine	pz. 1		Ruota 26 denti	pz. 1
	Barra doppia 7 fori	pz. 4		Gabbia portasatelliti	pz. 1		Ruota 41 denti	pz. 1
	Barra doppia 5 fori	pz. 4		Ruota 32 denti	pz. 1		Modulo di trasmissione	pz. 2
	Barra doppia 3 fori	pz. 4		Ruota 24 denti	pz. 1		Pneumatico	pz. 4
	Barra singola 15 fori	pz. 4		Ruota 12 denti	pz. 9		Cerchione	pz. 4
	Barra singola 13 fori	pz. 4		Giunto cardanico	pz. 2		Volante	pz. 1
	Barra singola 9 fori	pz. 4		Chiodino corto doppio	pz. 32		Rocchetto	pz. 1
	Barra singola 7 fori	pz. 4		Chiodino corto singolo	pz. 16		Puleggia	pz. 4
	Barra singola 5 fori	pz. 4		Chiodino corto libero	pz. 32		Filo	pz. 1
	Barra singola 3 fori	pz. 4		Chiodino corto doppio	pz. 16		Motore	pz. 1
	Modulo ad angolo alto	pz. 4		Chiodino lungo libero	pz. 16		Vano batterie	pz. 1
	Modulo ad angolo basso	pz. 4		Barra con chiodini	pz. 4		Cabina autogru	pz. 1
	Modulo ad angolo basso	pz. 2		Barra con perni	pz. 4		Pannello cabina DX	pz. 1
	Barra T	pz. 2		Gancio	pz. 1		Pannello cabina SX	pz. 1
	Barra ad angolo	pz. 4		Manovella	pz. 2			
	Astina 6 lunga cm. 11,7	pz. 2		Asta dentata	pz. 1			
	Astina 5 lunga cm. 8,1	pz. 2						
	Astina 4 lunga cm. 7,2	pz. 2						
	Astina 3 lunga cm. 5,4	pz. 10						
	Astina 2 lunga cm. 3,6	pz. 4						
	Astina 1 lunga cm. 2,7	pz. 2						

Le carrucole

La carrucola è una macchina semplice capace di sollevare i pesi. È una ruota girevole attorno ad un asse passante per il centro, sul bordo esterno è presente una scanalatura (gola) nella quale scorre una fune.



**Carrucola fissa
Indifferente!**



**Carrucola mobile
Vantaggiosa!**

La carrucola è una macchina che permette di sollevare un peso esercitando lo sforzo nel verso più facile, dall'alto verso il basso e quindi di trovare la direzione più comoda per compiere lo sforzo.

1 Gru con carrucola fissa

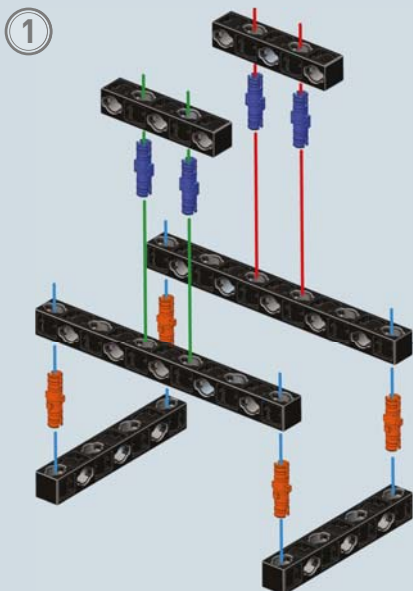
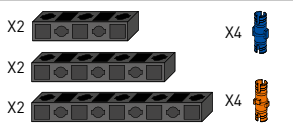

Lege un capo del filo al rocchetto, poi fallo passare per la puleggia e infine lega l'altro capo al gancio.

②

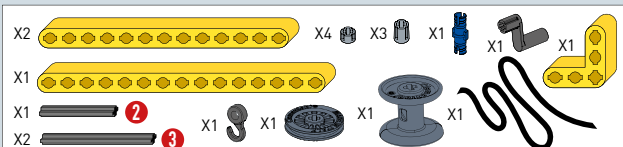
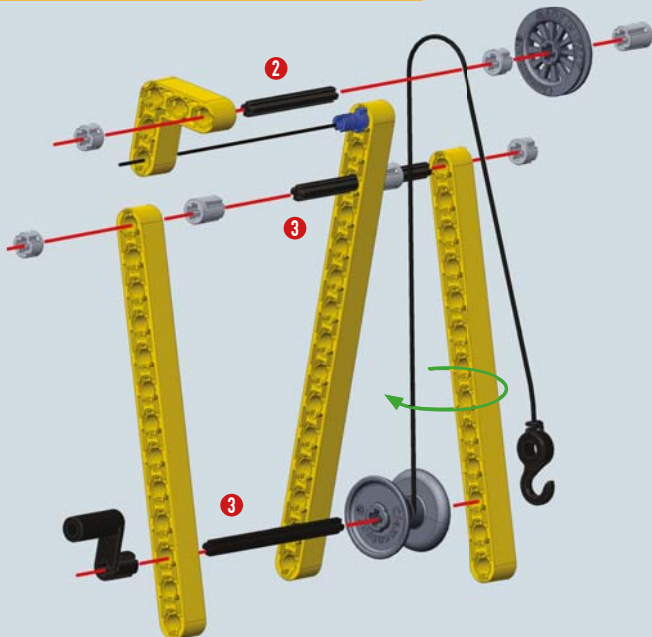

- X8
- X2

3

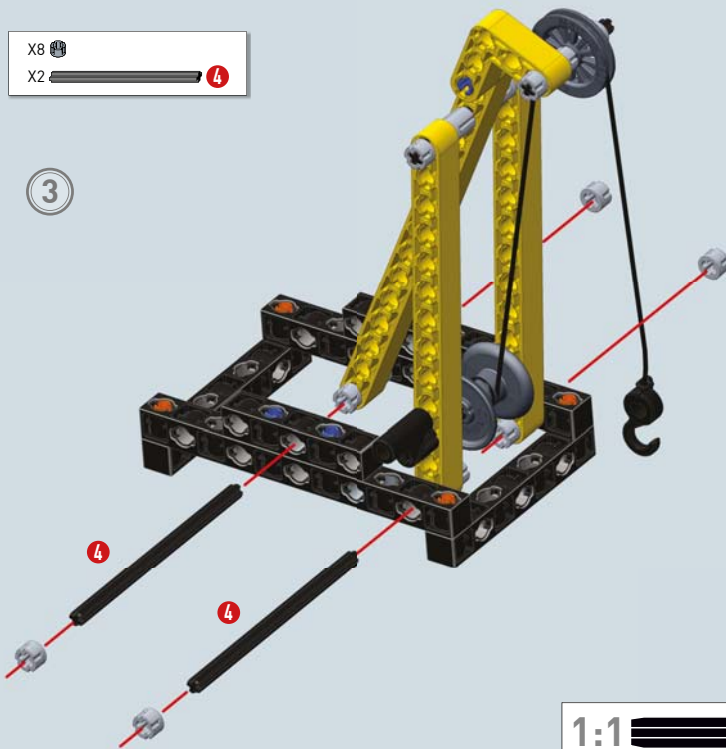

Modello finale

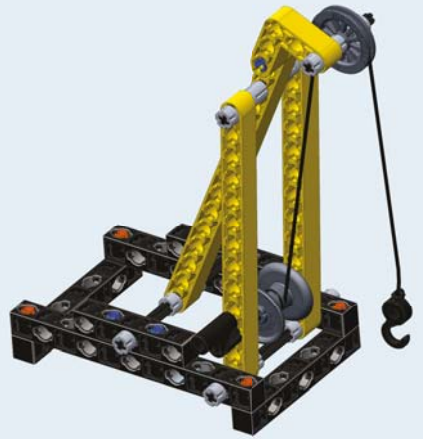

- 1:1

2 Gru con carrucola mobile

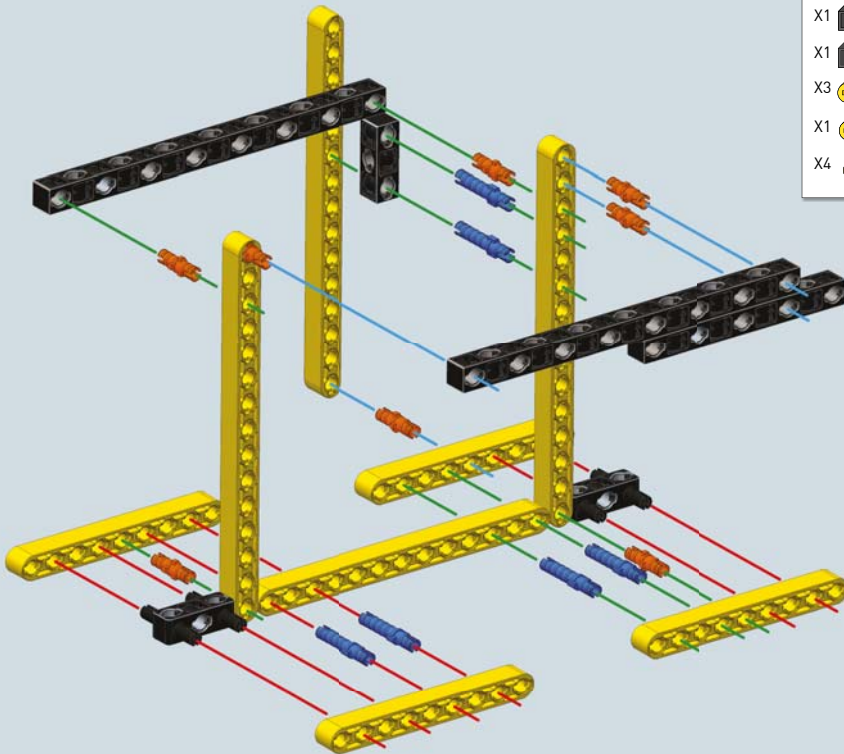

- X2
- X1
- X1
- X3
- X1
- X4
- X8
- X8
- X2

1



- X2
- X1
- X4
- X2

2

- X1
- X1
- X2
- X4
- X5
- X1
- X2
- X1
- X1

3

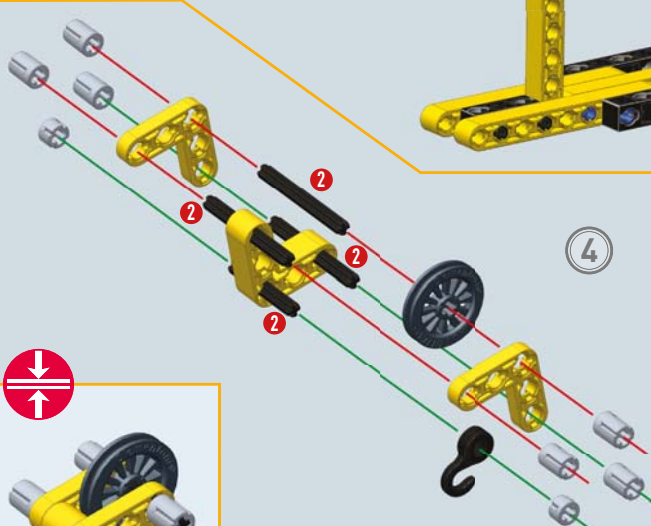
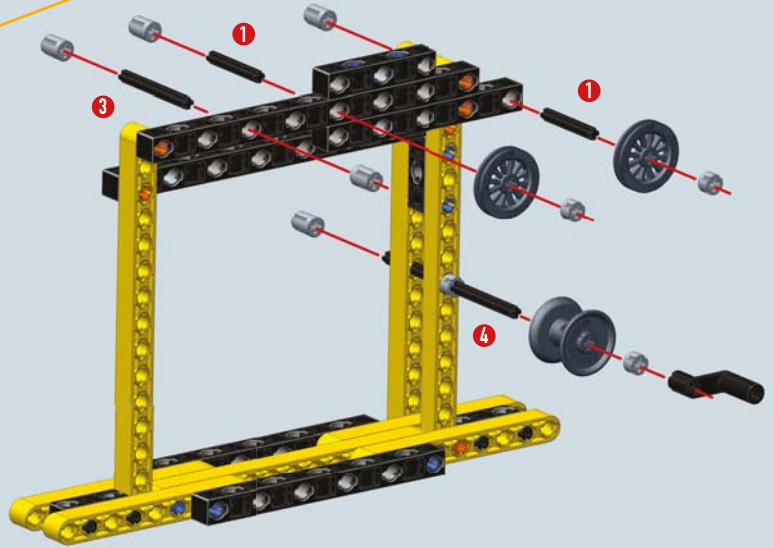

4



- X4
- X2
- X1
- X1
- X6
- X1
- X2
- X1
- X1

Modello finale



Leγα un capo del filo al rocchetto e fallo passare per le pulegge come indicato, poi lega l'altro capo all'astina 3



- X2
- X1
- X2
- X4
- X4
- X2
- X1

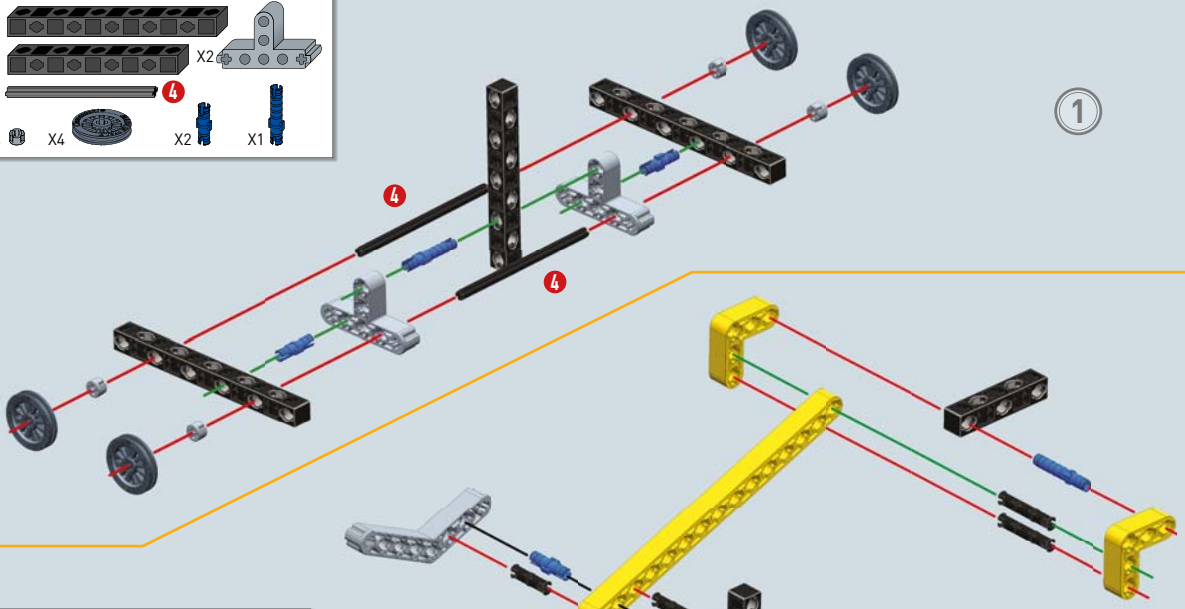

1

- X1
- X1
- X1
- X1
- X1
- X1
- X2
- X2

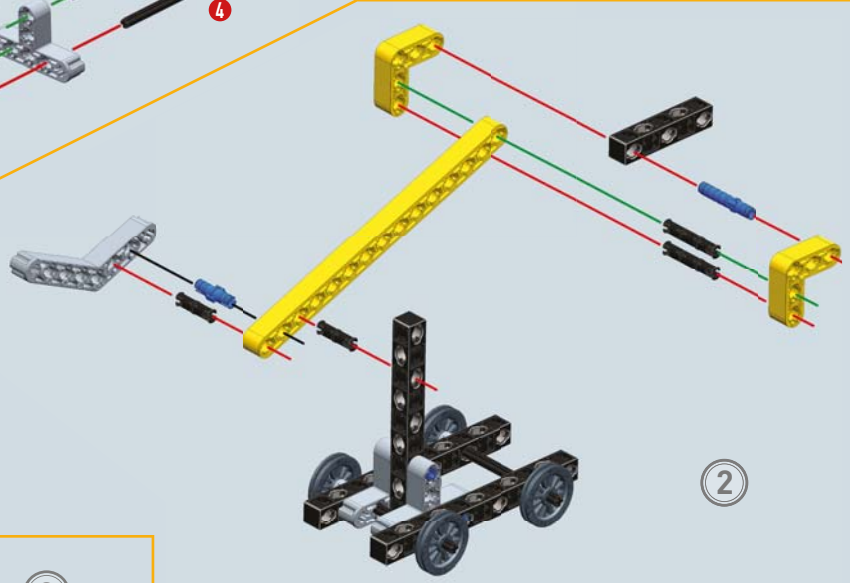

2

- X1
- X1
- X1
- X3
- X1
- X1
- X1
- X1
- X1

3

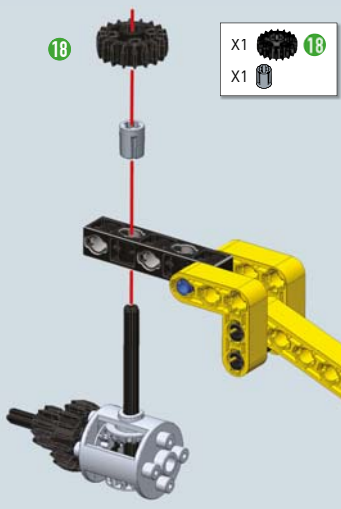
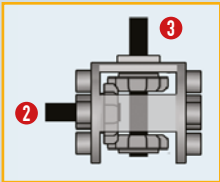
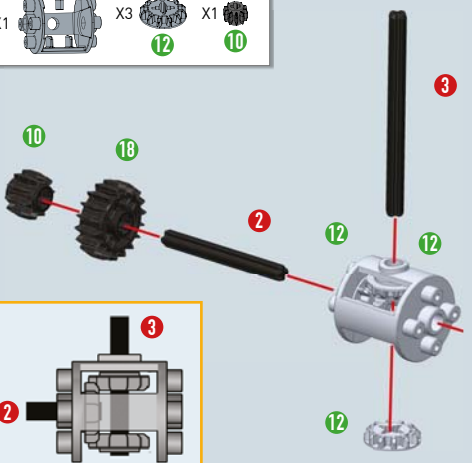

4

- X1
- X1



Modello finale





- X2
- X1
- X3
- X4

1

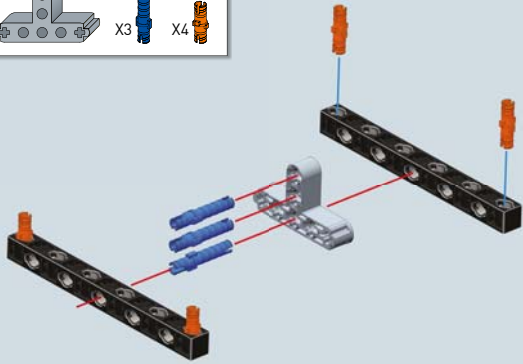

2

- X2
- X4
- X2

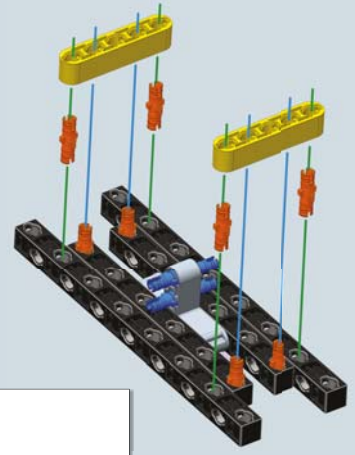

- X1
- X1
- X1
- X2
- X3
- X2

3

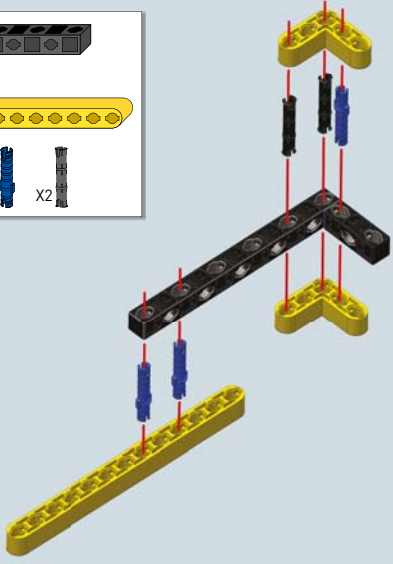

-
- X1
- X1

4

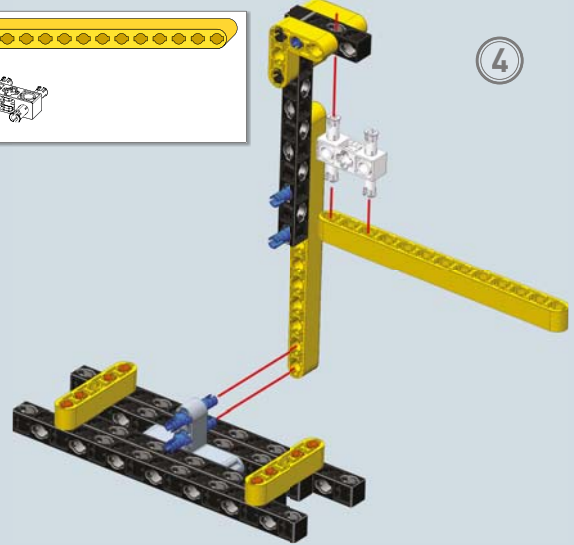

- X1
- X1
- X1
- X1
- X1
- X1

5

Lega il filo al rocchetto

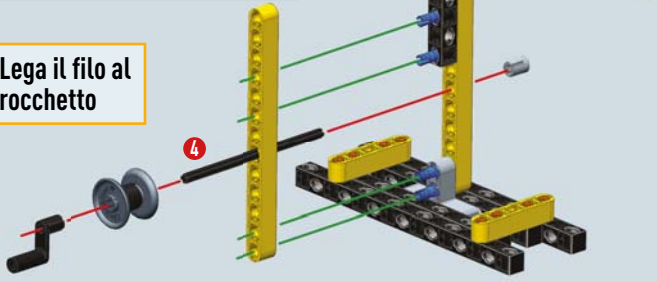

- X1

Modello finale

6

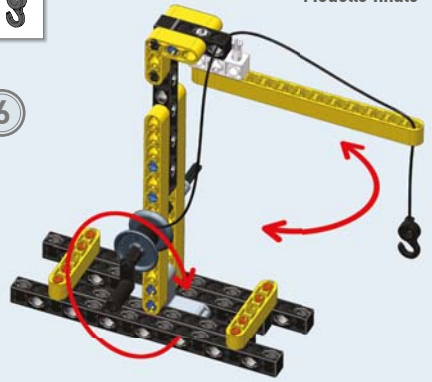

Fai passare il filo nei fori come in figura, poi lega il gancio

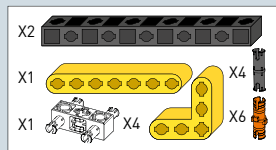
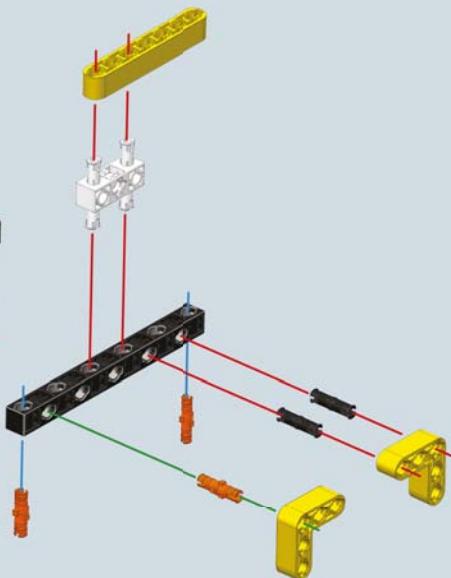
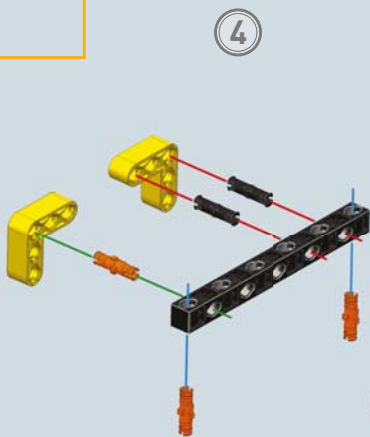
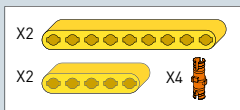
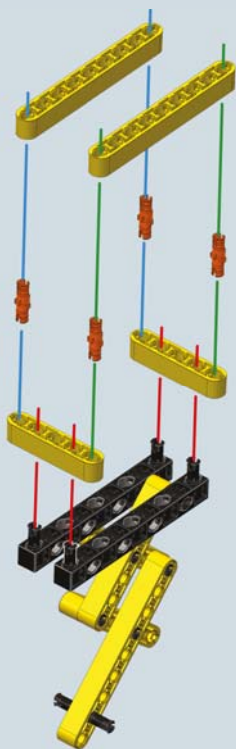
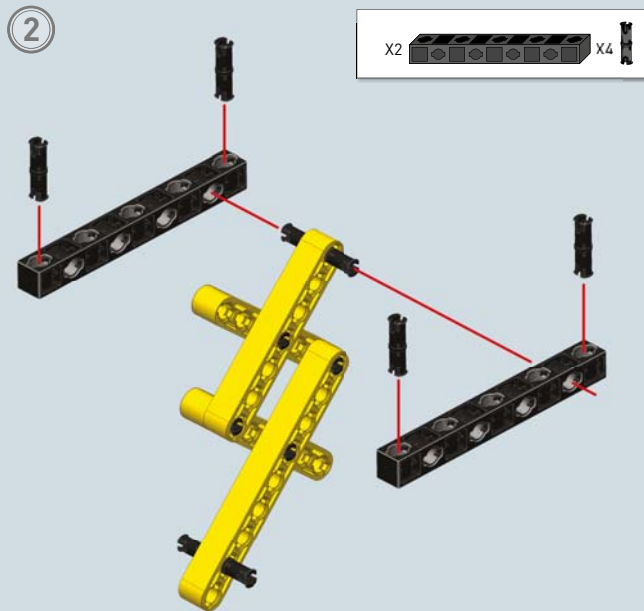
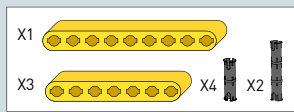
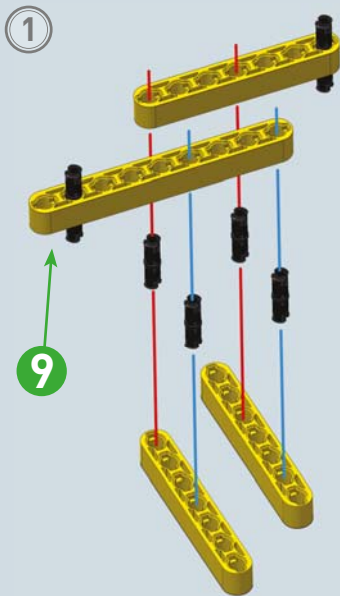

7

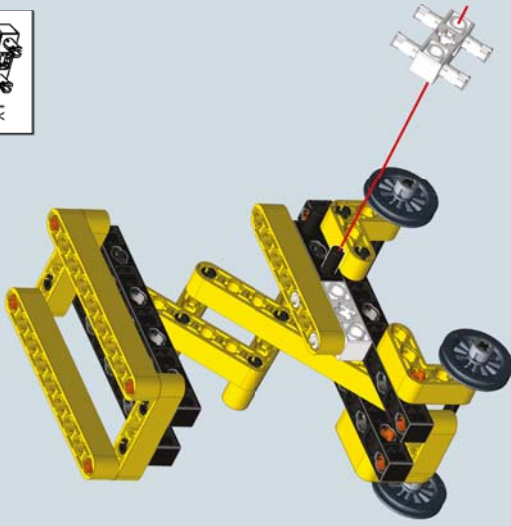

Modello finale

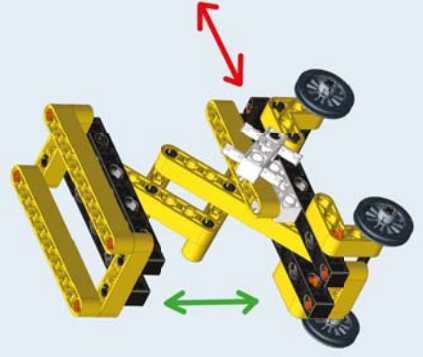

5

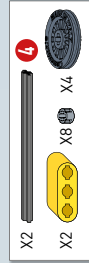
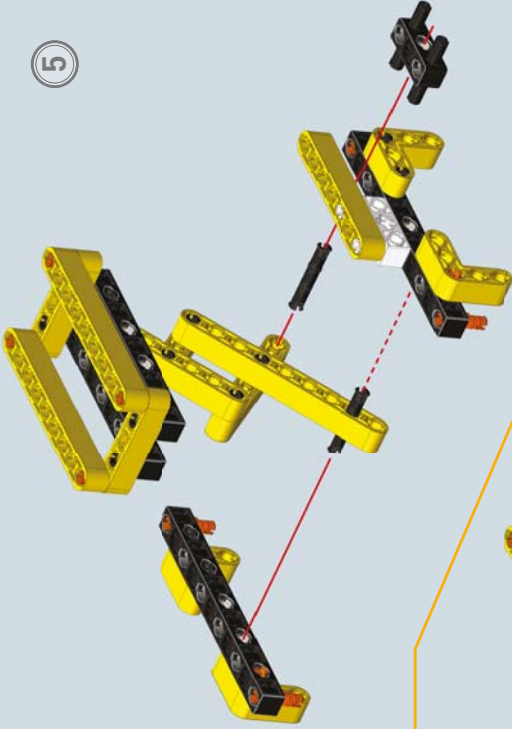

6

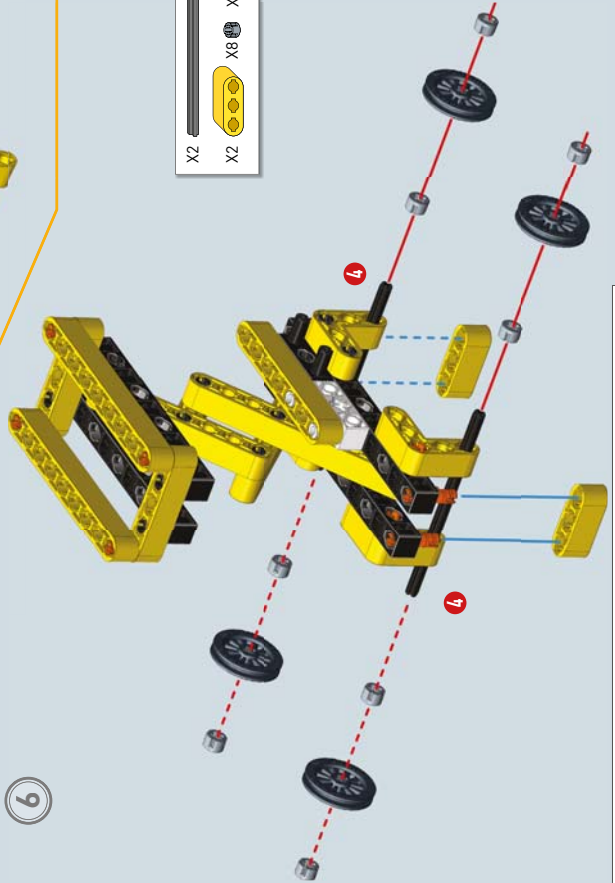



1

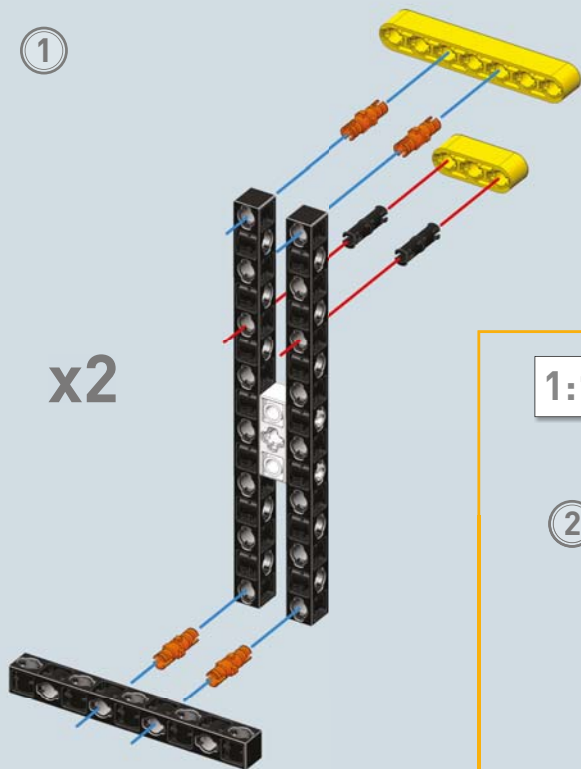

x2

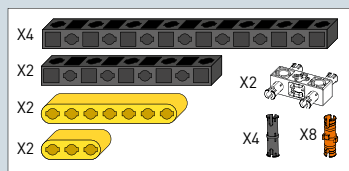

1:1



1:1



2

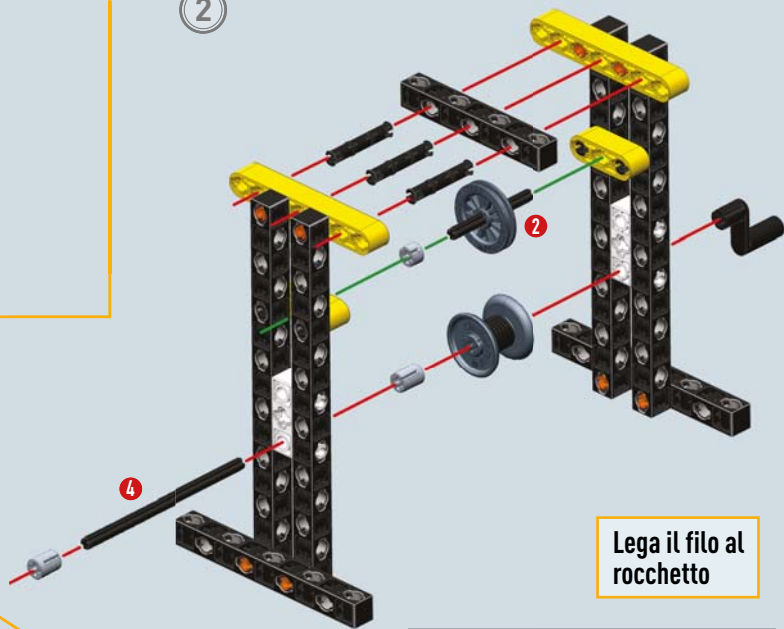

Leγα il filo al rocchetto

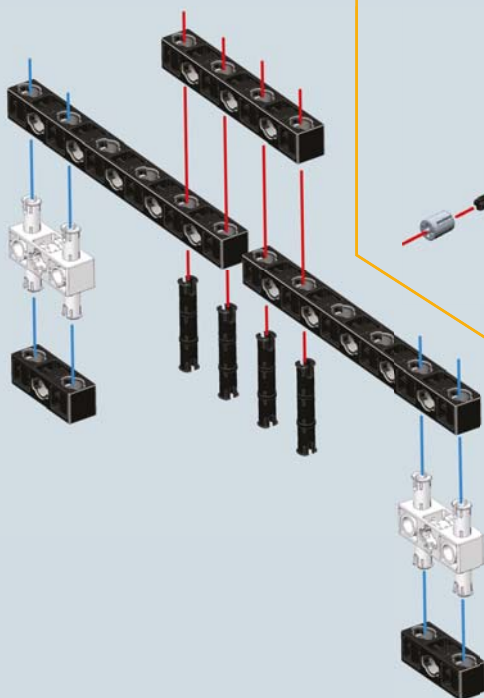
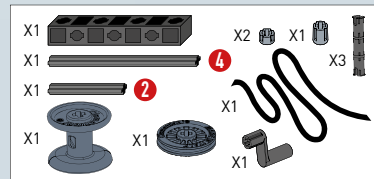

3

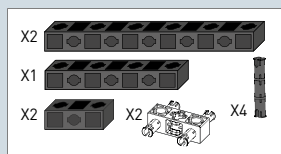

1:1

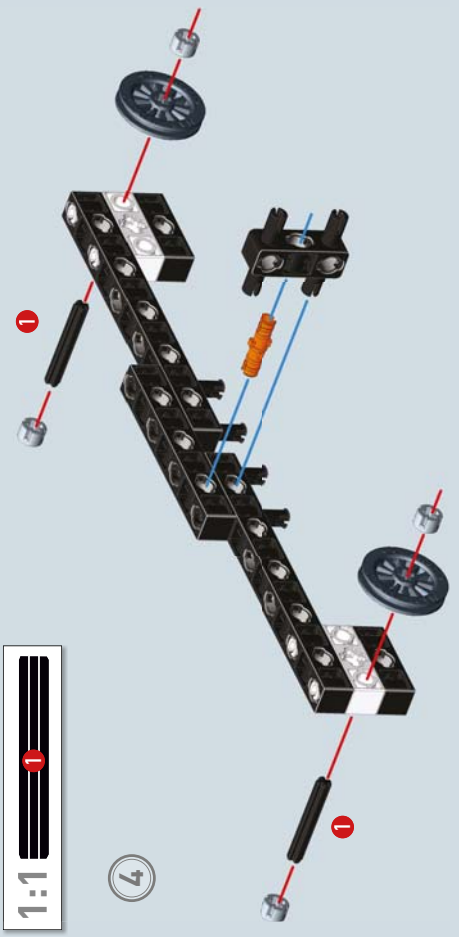

4

- X2
- X4
- X1
- X2
- X1



6

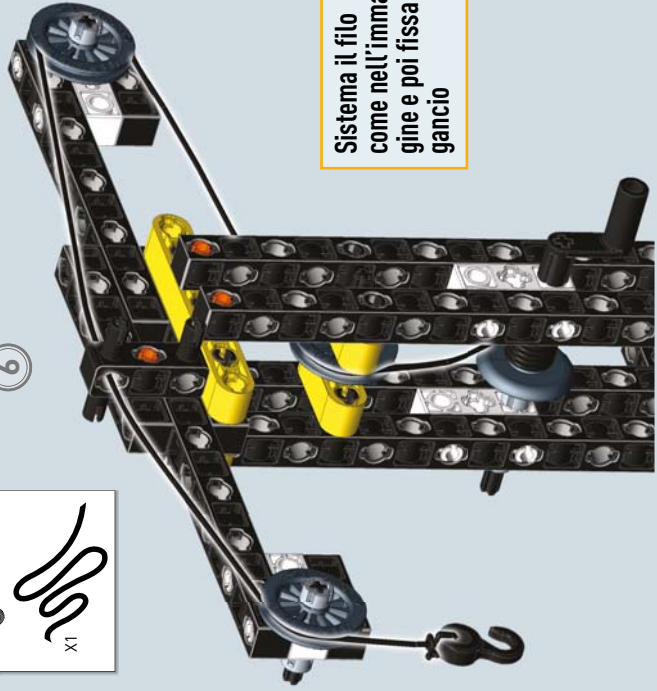

Sistema il filo come nell'immagine e poi fissa il gancio

5

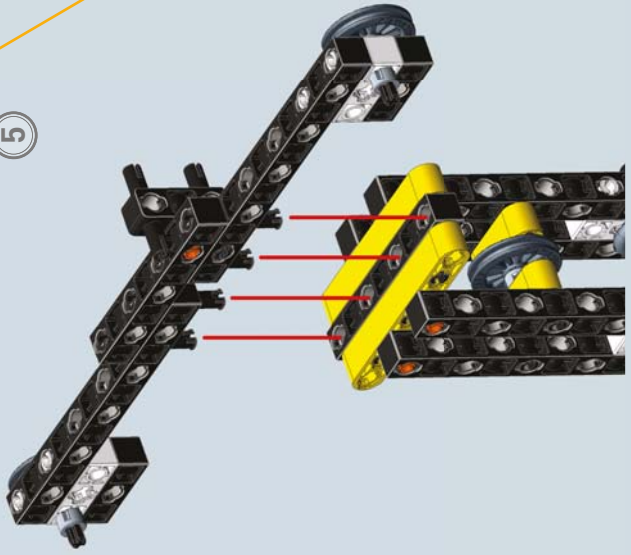

Modello finale

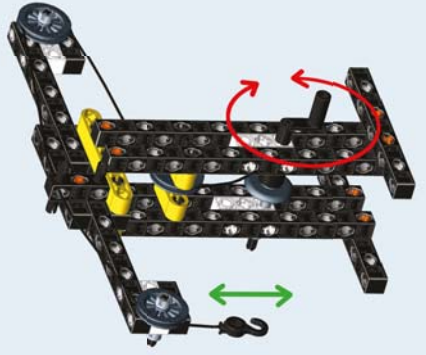

Notizie tecniche e curiosità
 La gru con argano centrale fa parte di una serie di schizzi che Leonardo da Vinci realizzò studiando le gru utilizzate al suo tempo. Oltre a questo modello disegnò gru con basi girevoli che potevano essere trainate e per brevi tratti. Questi modelli erano pensati per lavorare in prossimità di cave di pietra o per facilitare lo spostamento di materiale nello scavo dei canali.

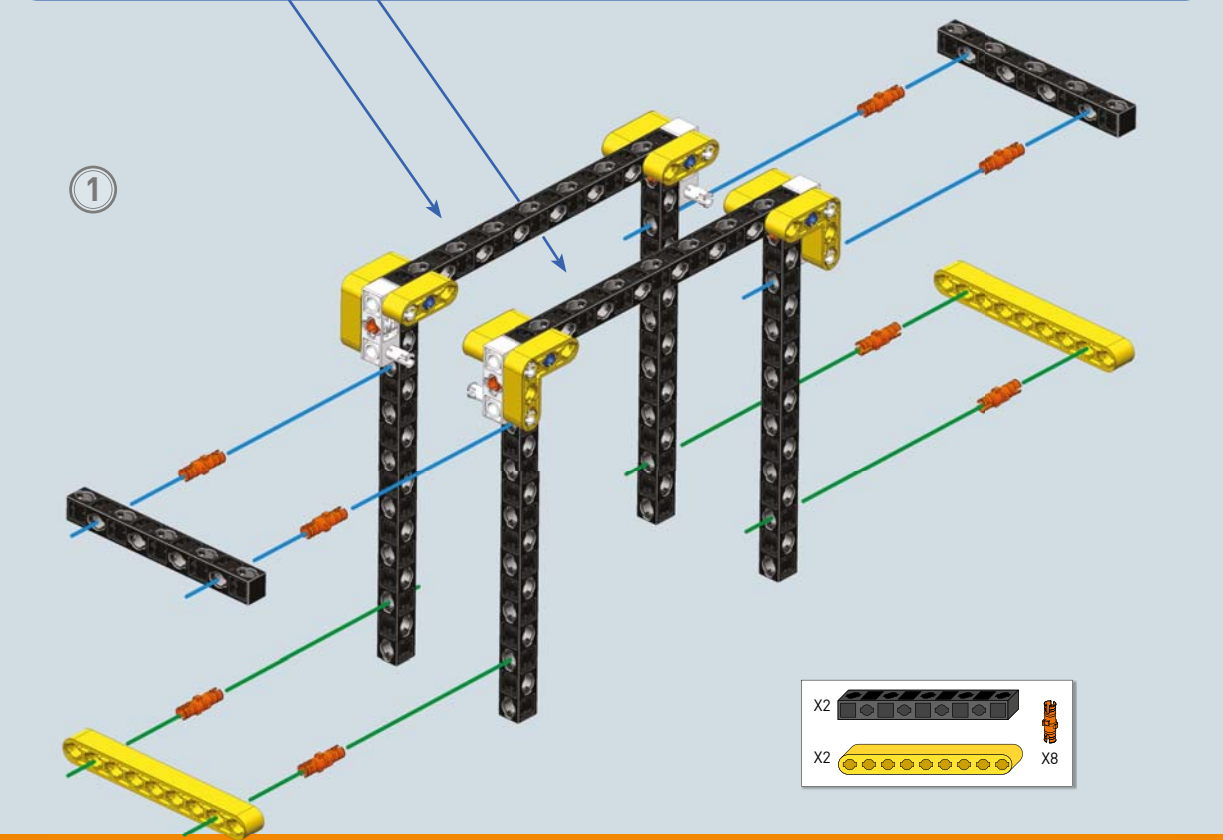
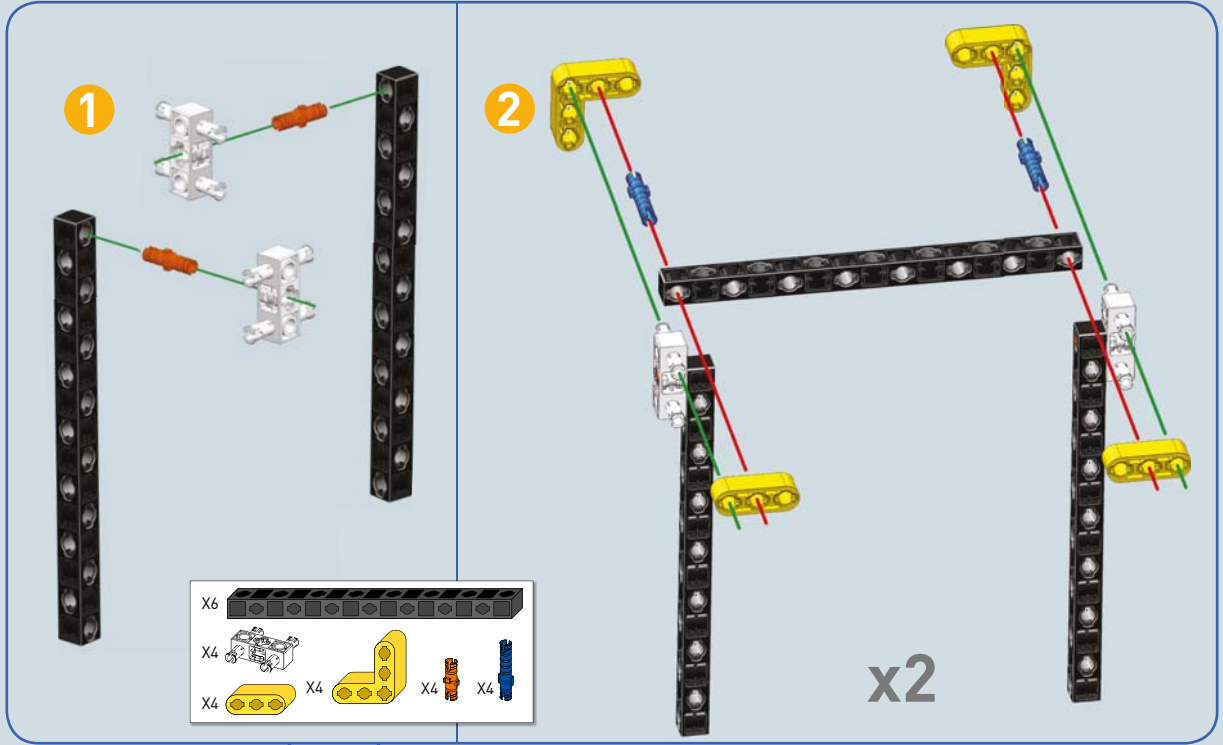

1:1 

1:1 

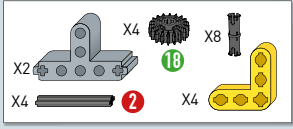

2

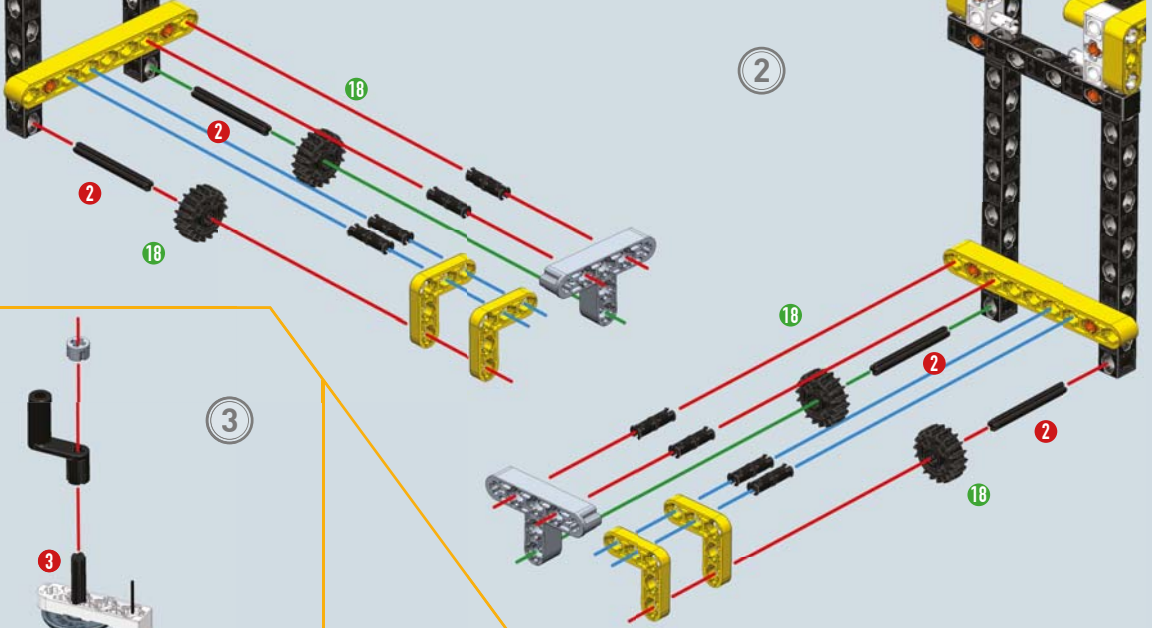

3

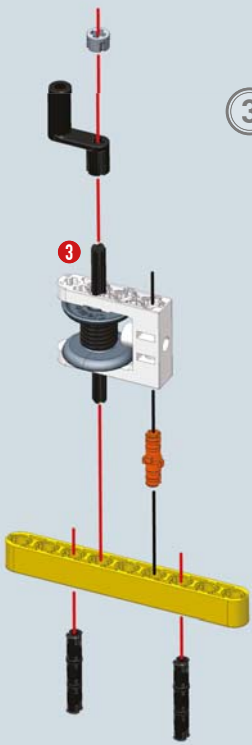

4

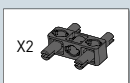
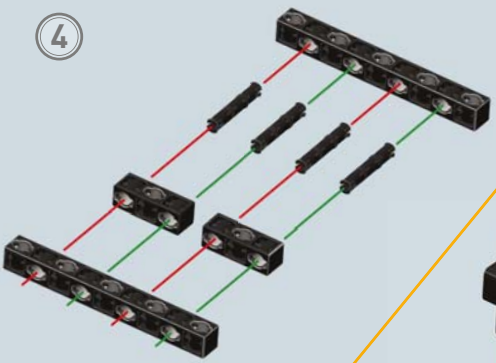

5

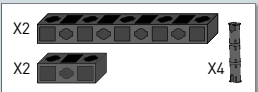
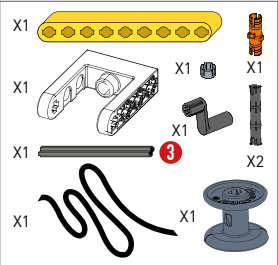
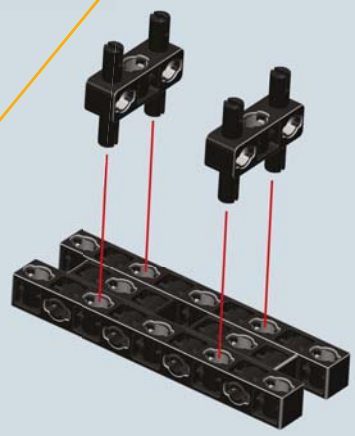

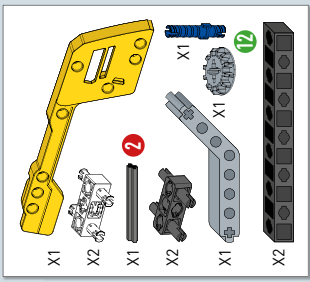

3

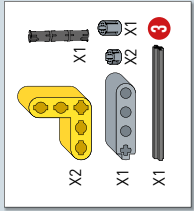
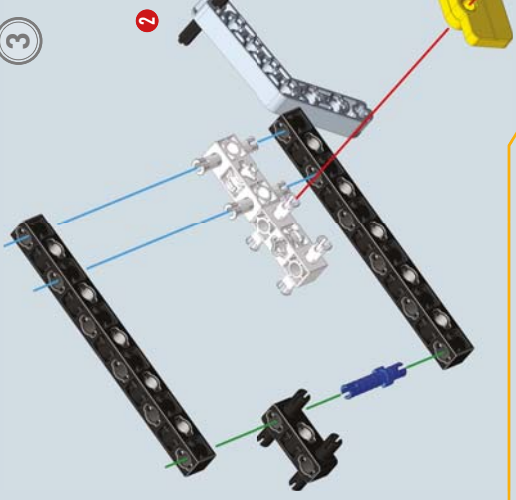

4

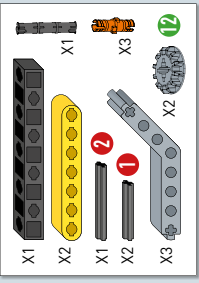
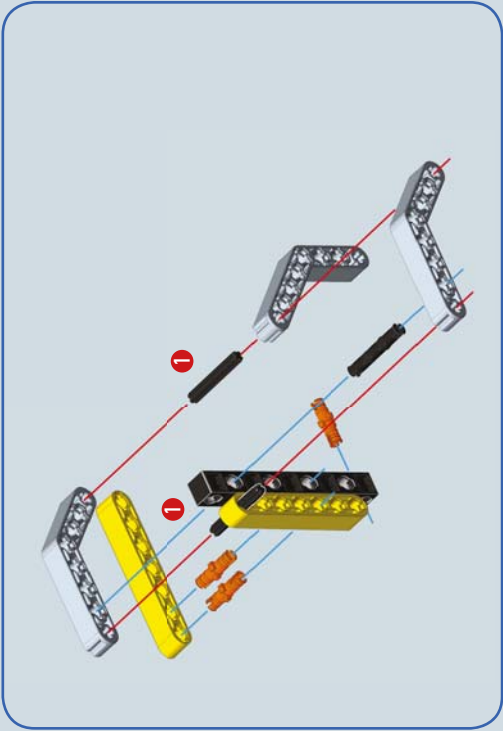
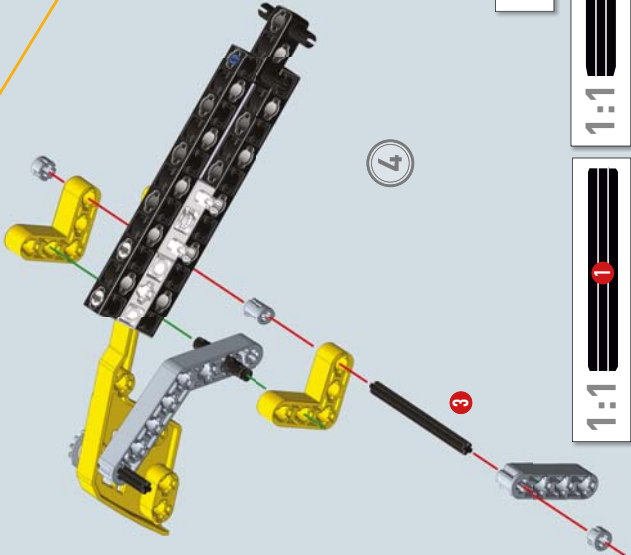

2

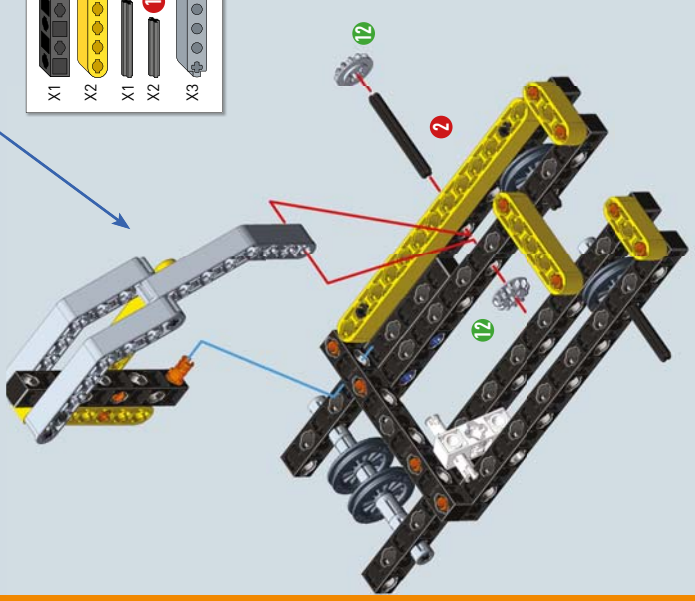

5

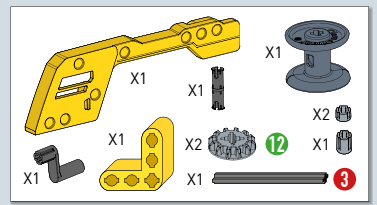
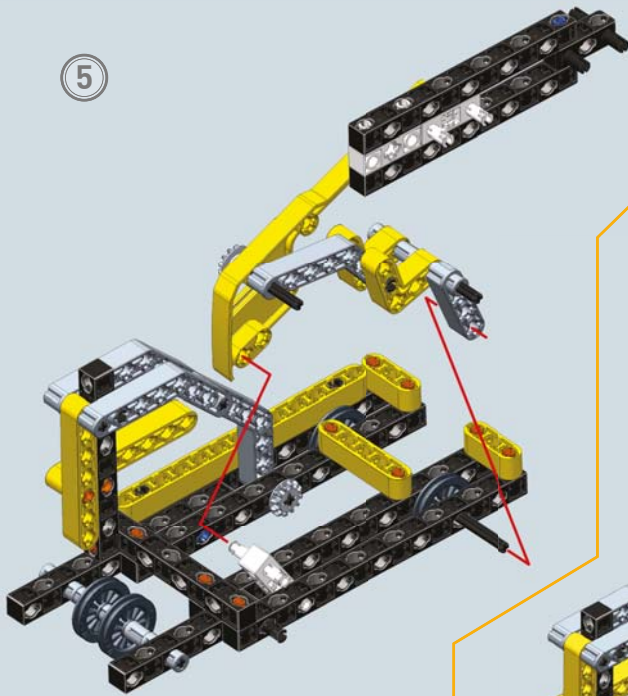

6

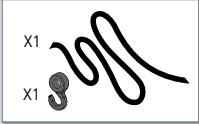
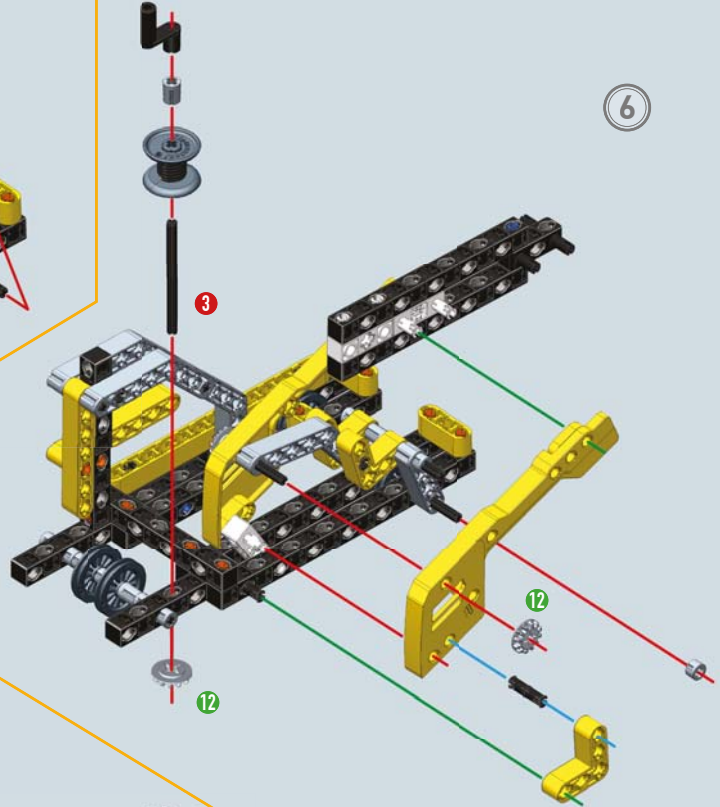

Fai passare il filo nei fori
come in figura, poi lega il
gancio

7

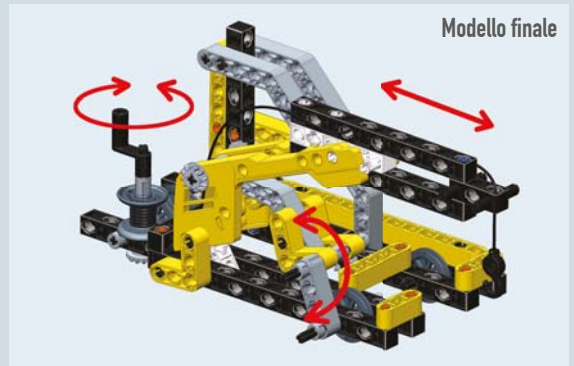
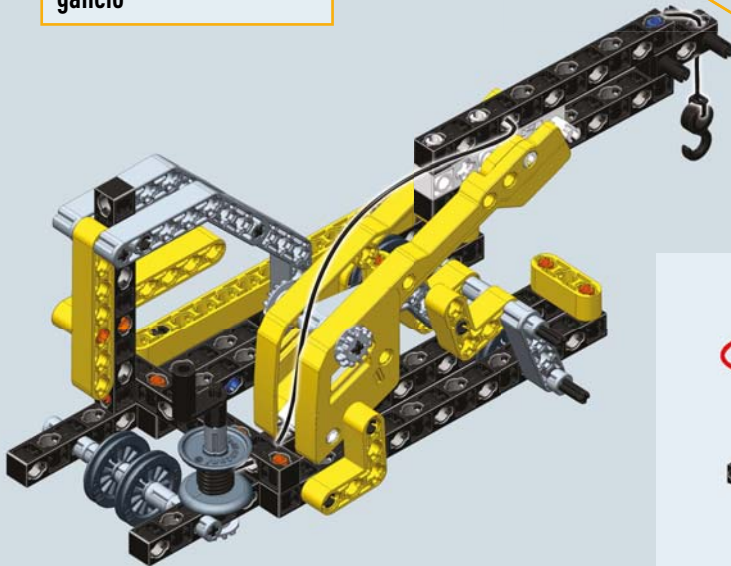

1:1 

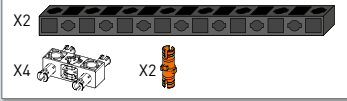

1

x2

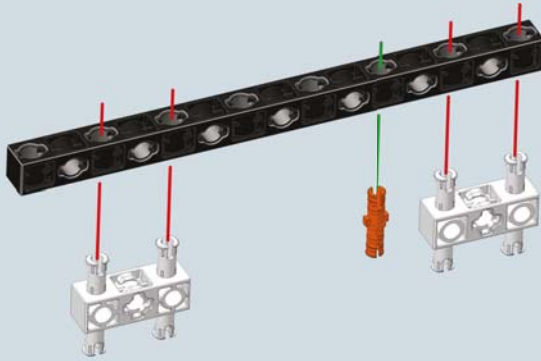

È una macchina che permette di sollevare l'operatore dalle altezze considerevoli. Il sollevamento viene effettuato tramite pistoni idraulici.

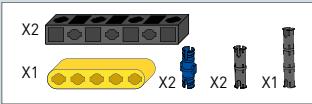

3

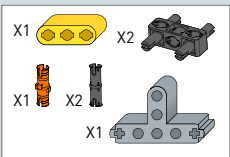
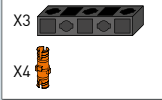
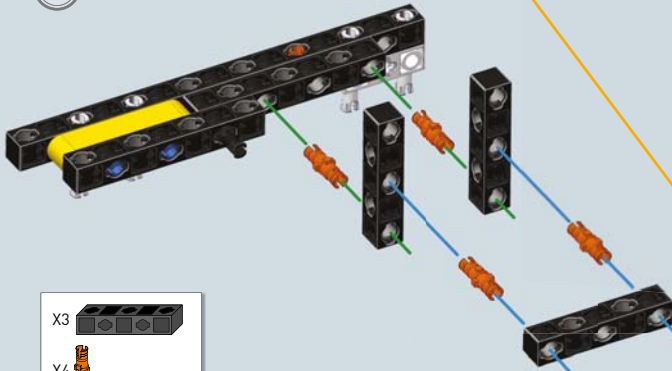

2

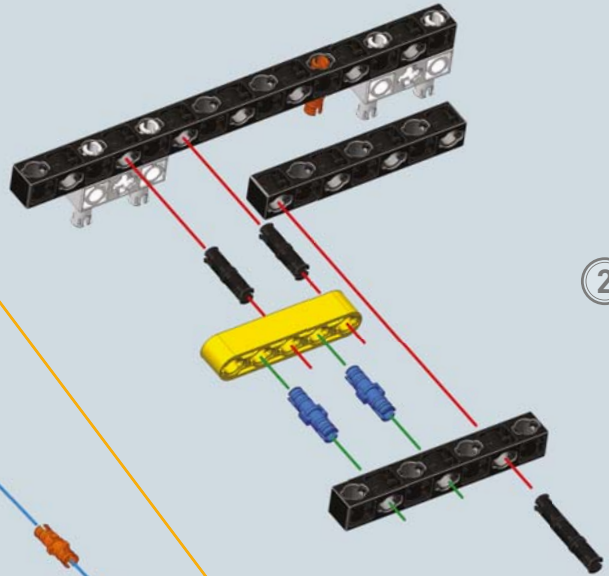

4

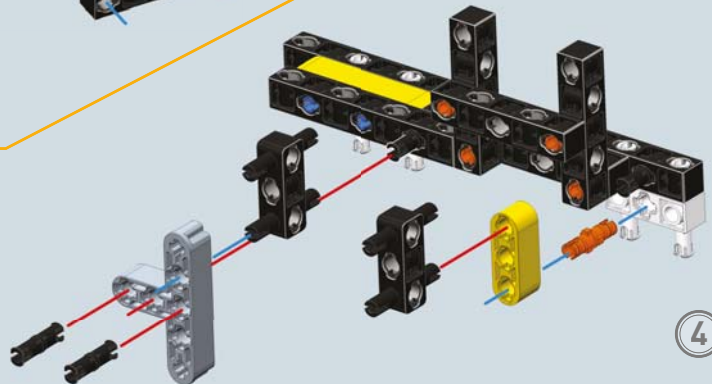

7

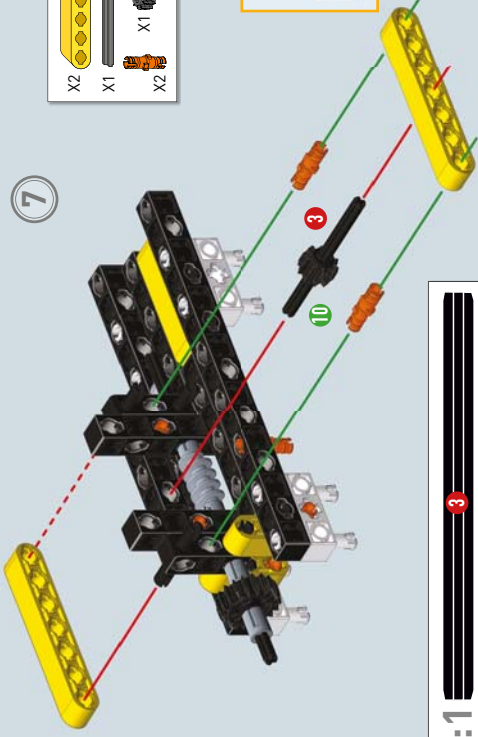

- X2
- X1
- X2
- X1
- X1

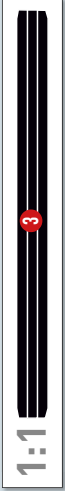

1:1

8

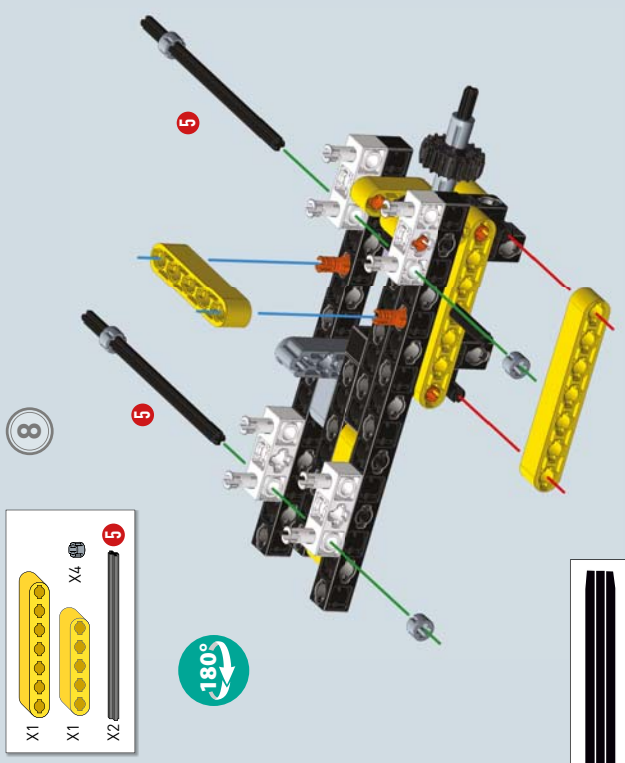

- X1
- X1
- X2
- X4
- X5



1:1

5

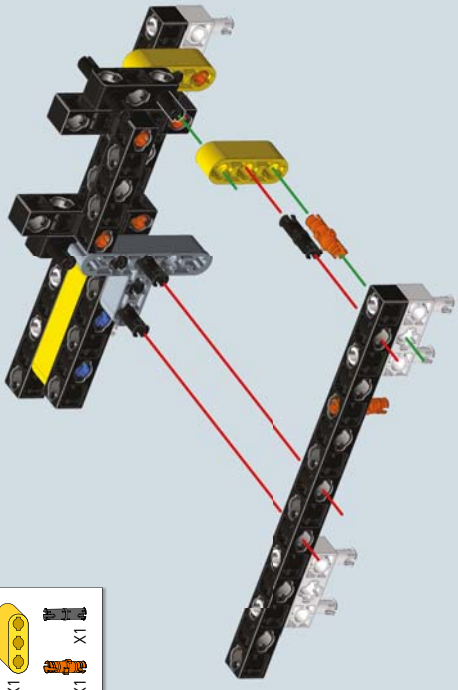

- X1
- X1
- X1
- X1

6

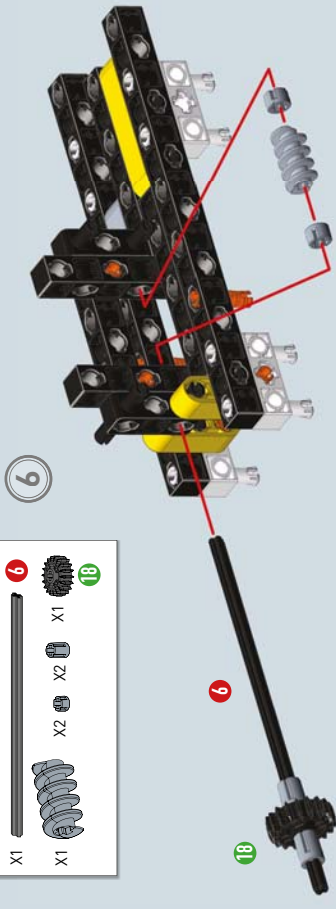

- X1
- X1
- X2
- X2
- X1
- X1



1:1



1:1

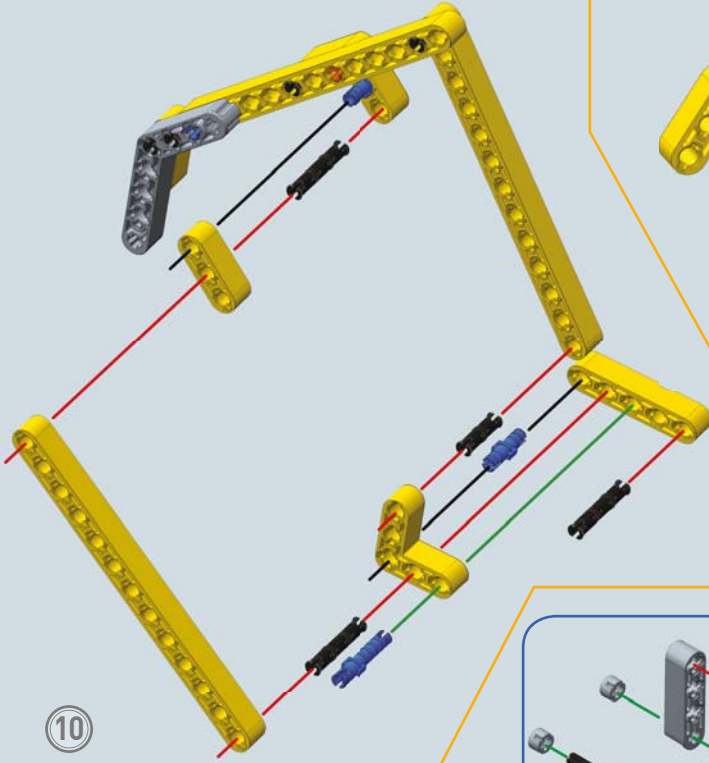
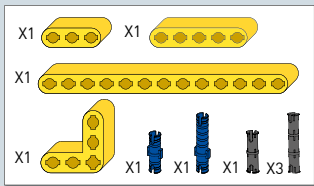

10

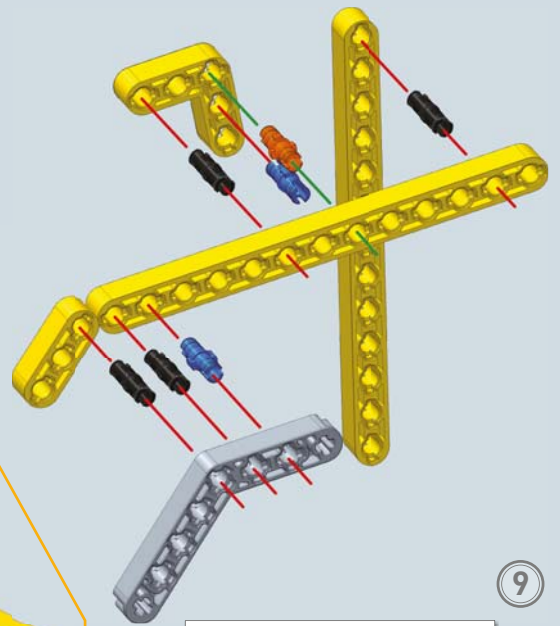

9

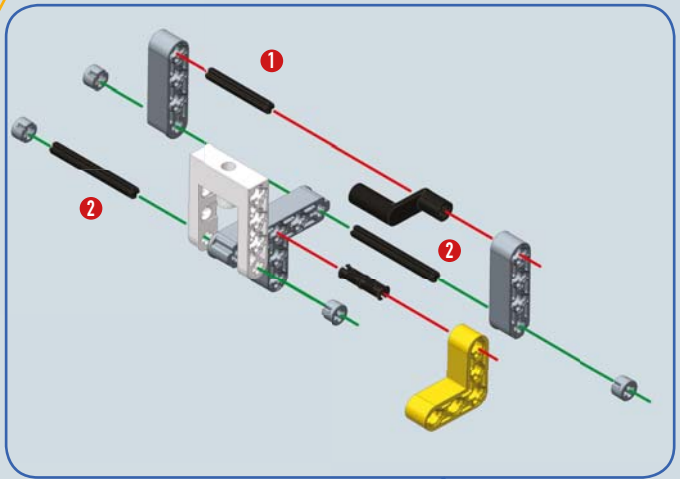
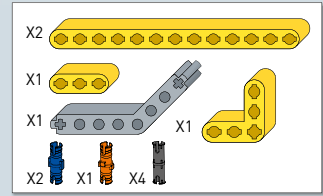

11

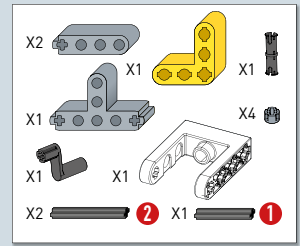
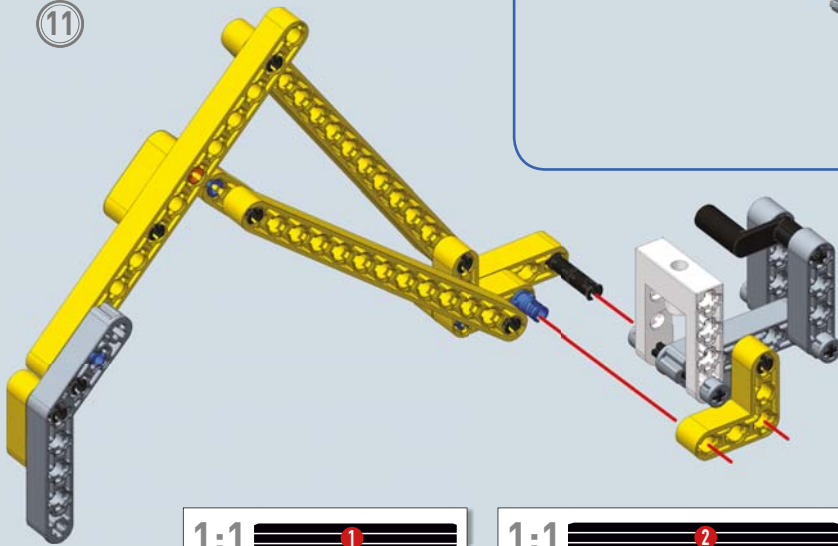

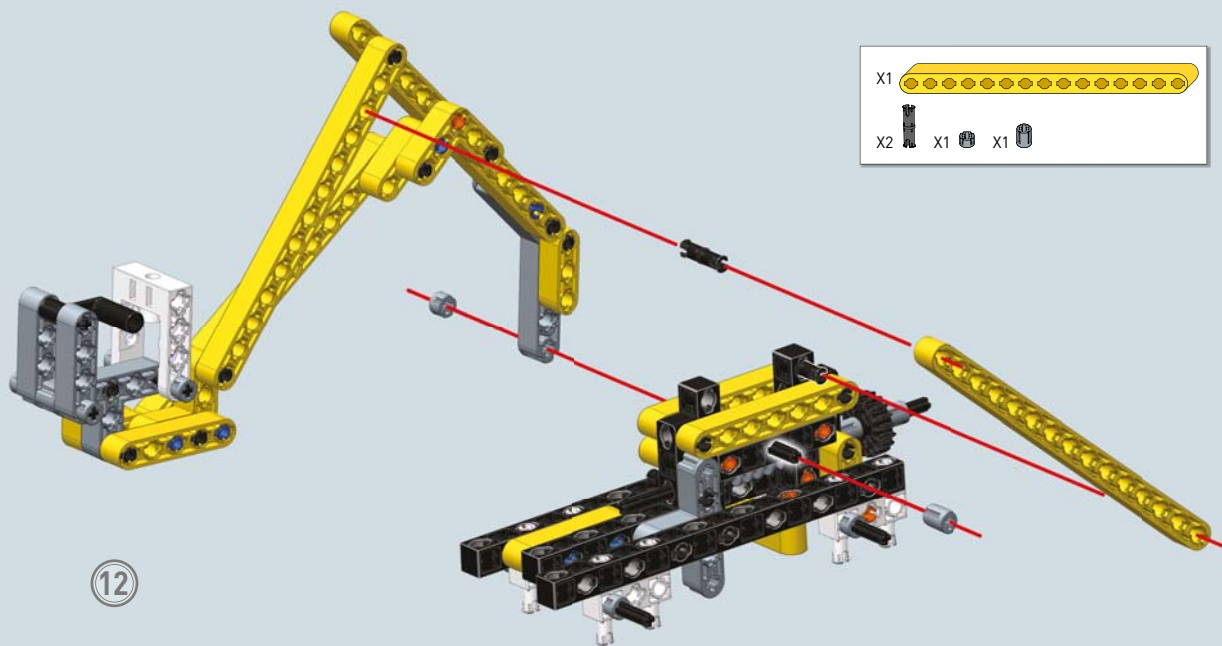

13

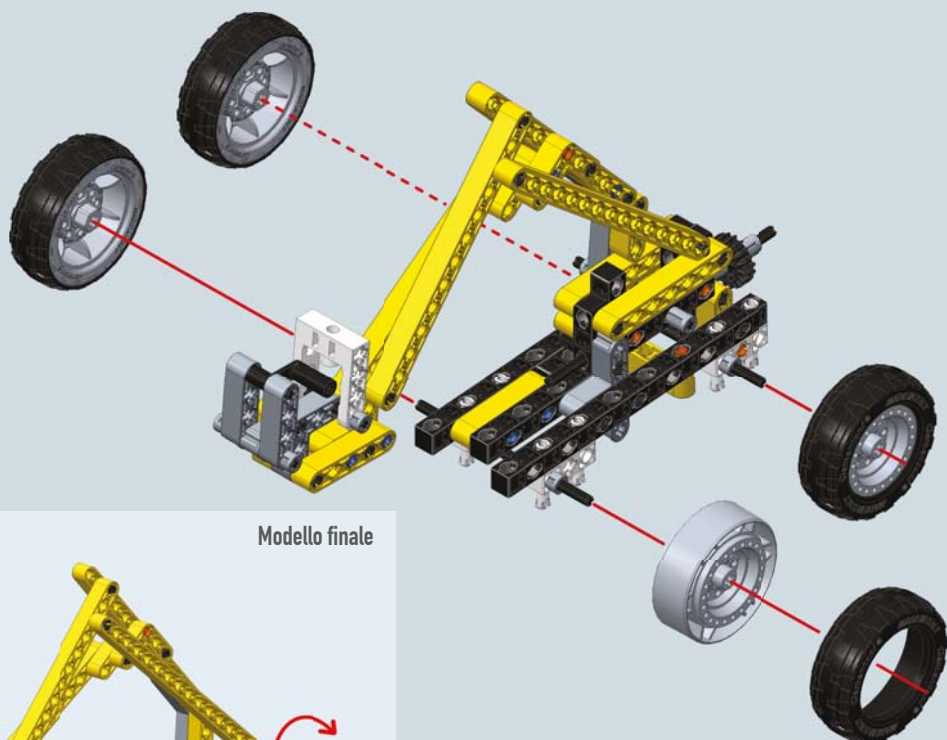

Modello finale

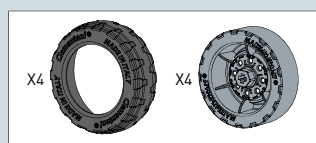

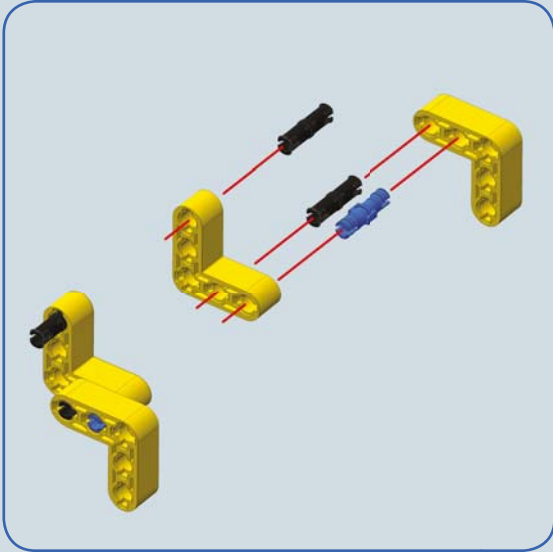

1

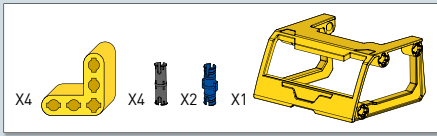
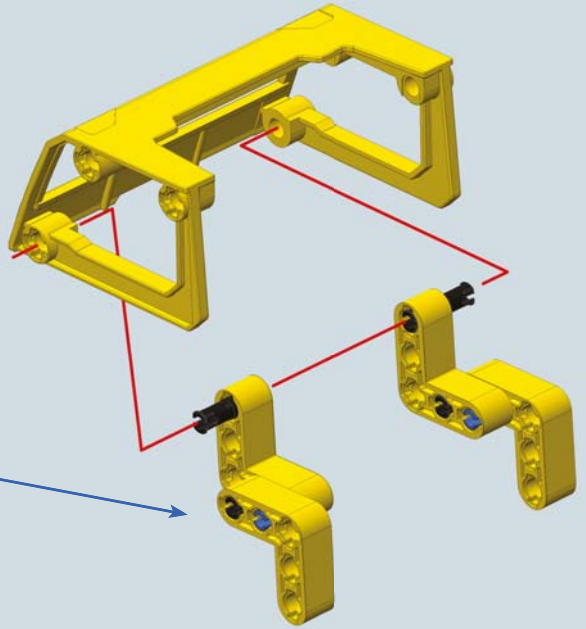

2

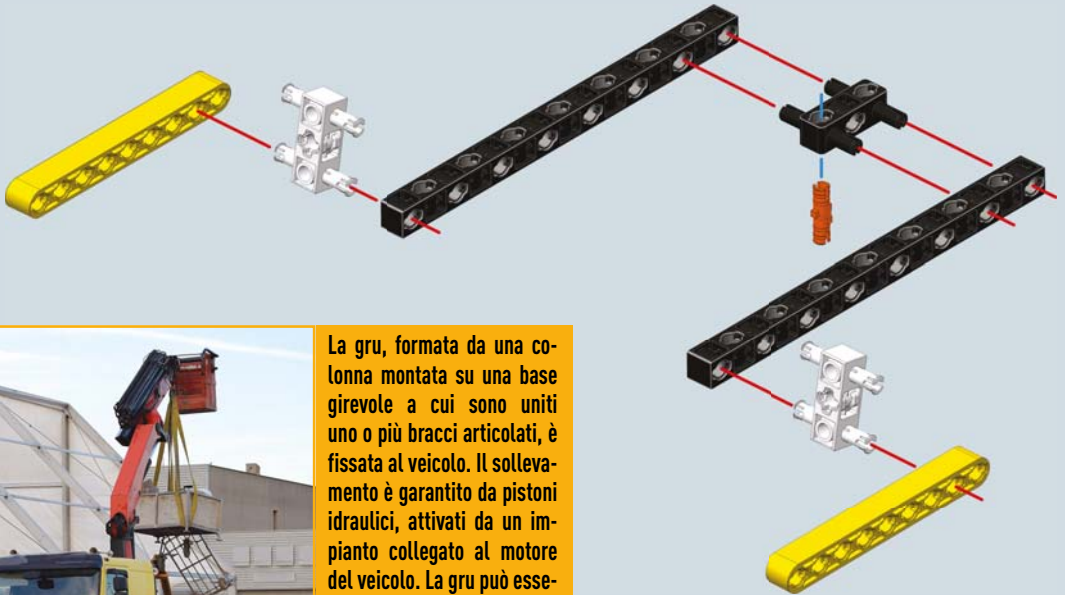

La gru, formata da una colonna montata su una base girevole a cui sono uniti uno o più bracci articolati, è fissata al veicolo. Il sollevamento è garantito da pistoni idraulici, attivati da un impianto collegato al motore del veicolo. La gru può essere montata dietro la cabina o in posizione posteriore.

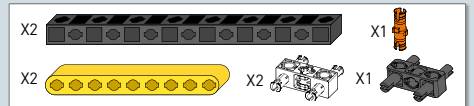

3

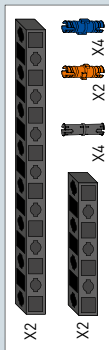
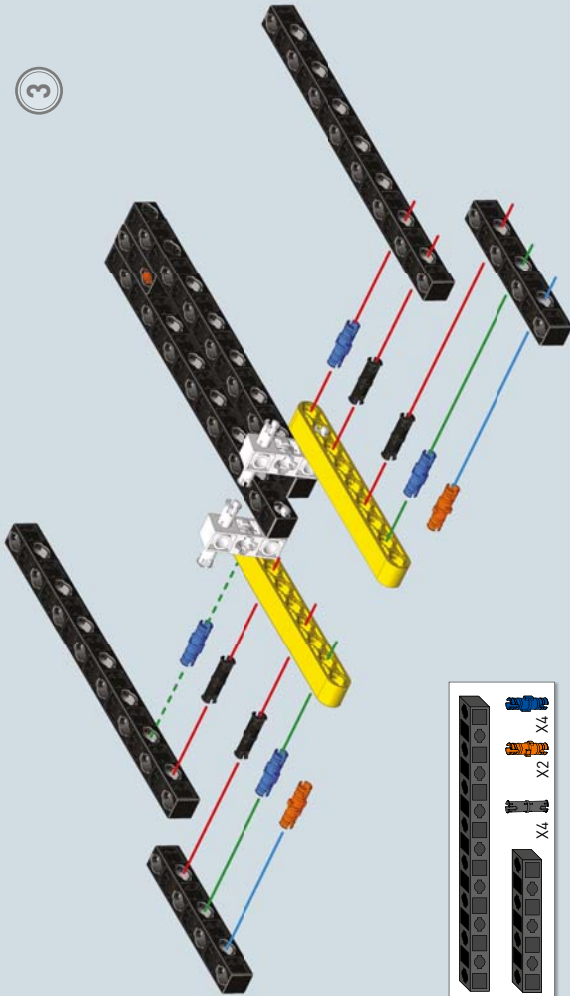

4

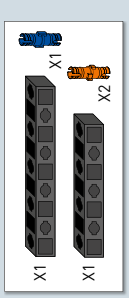
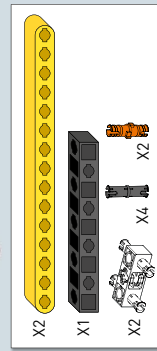
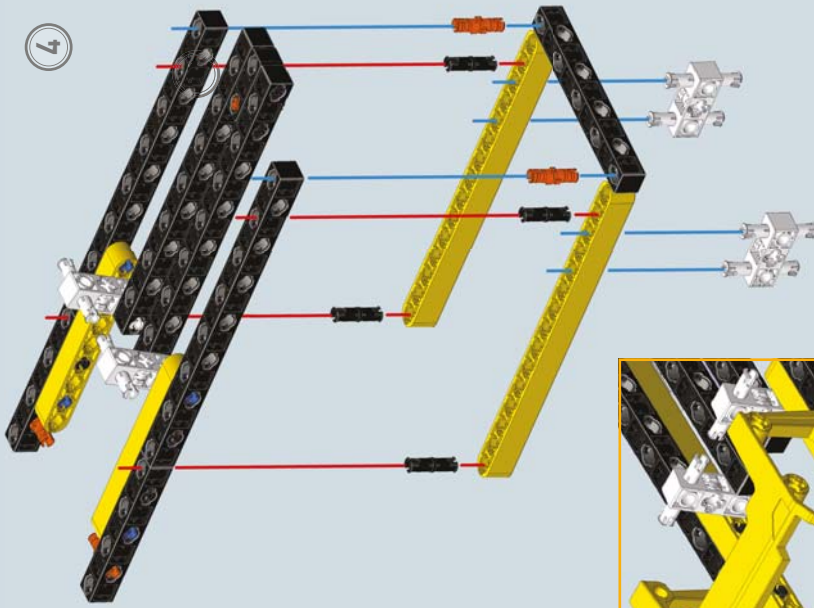

6

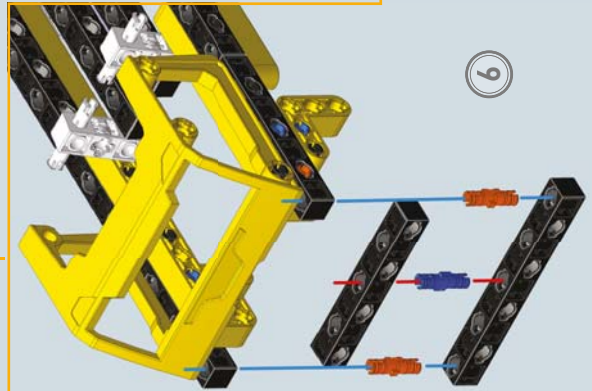

5

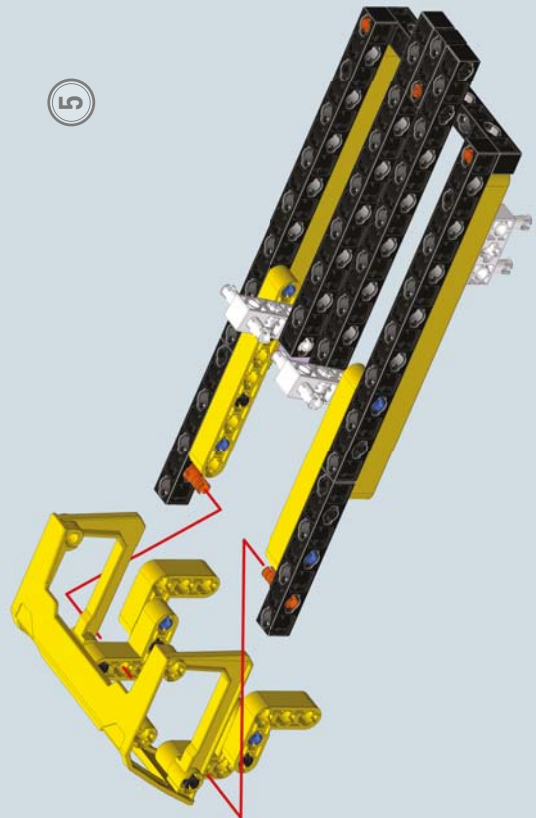

1:1 **6**

9

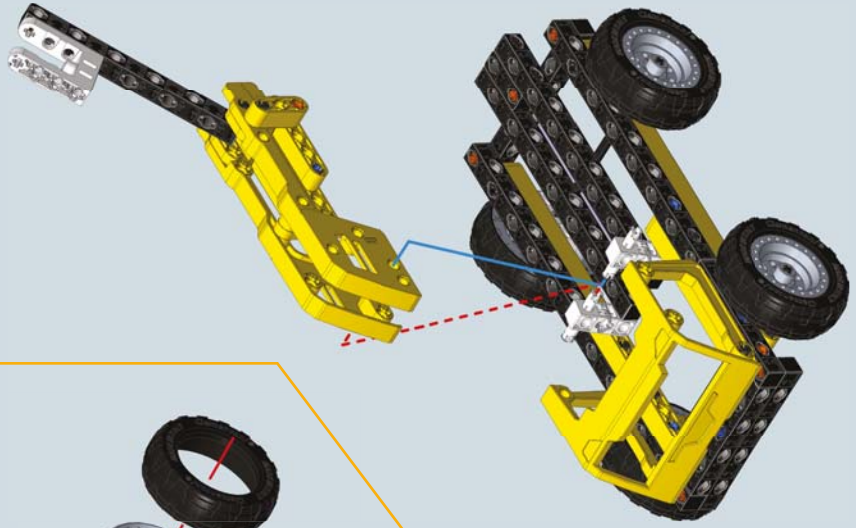

7

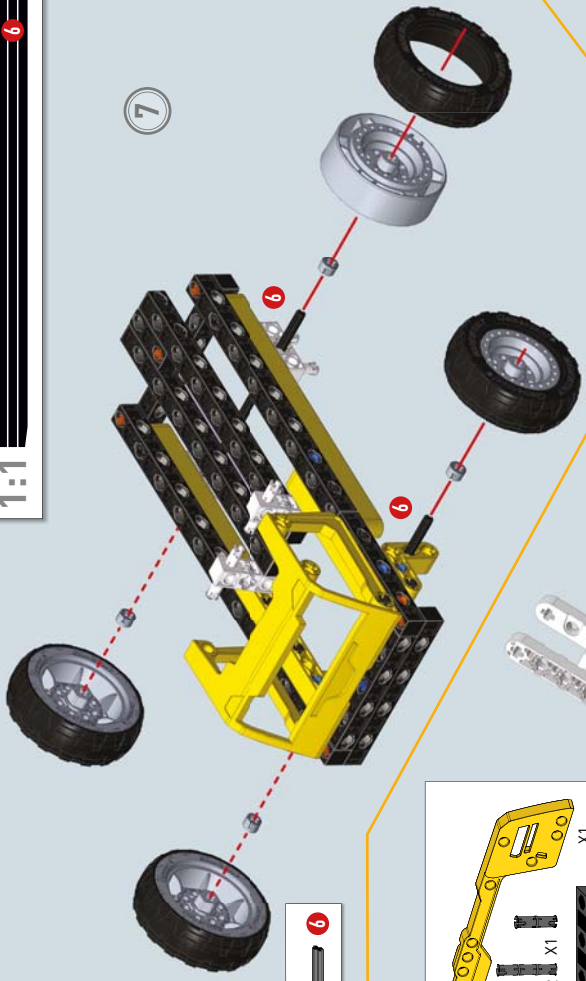

8

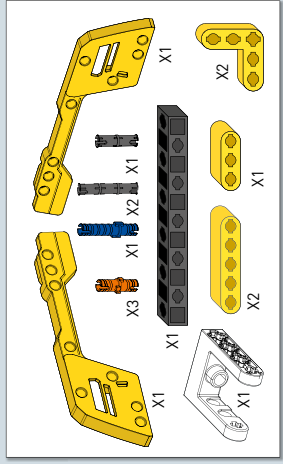
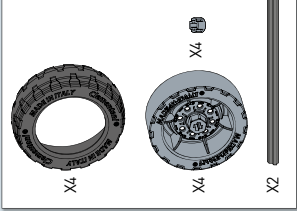
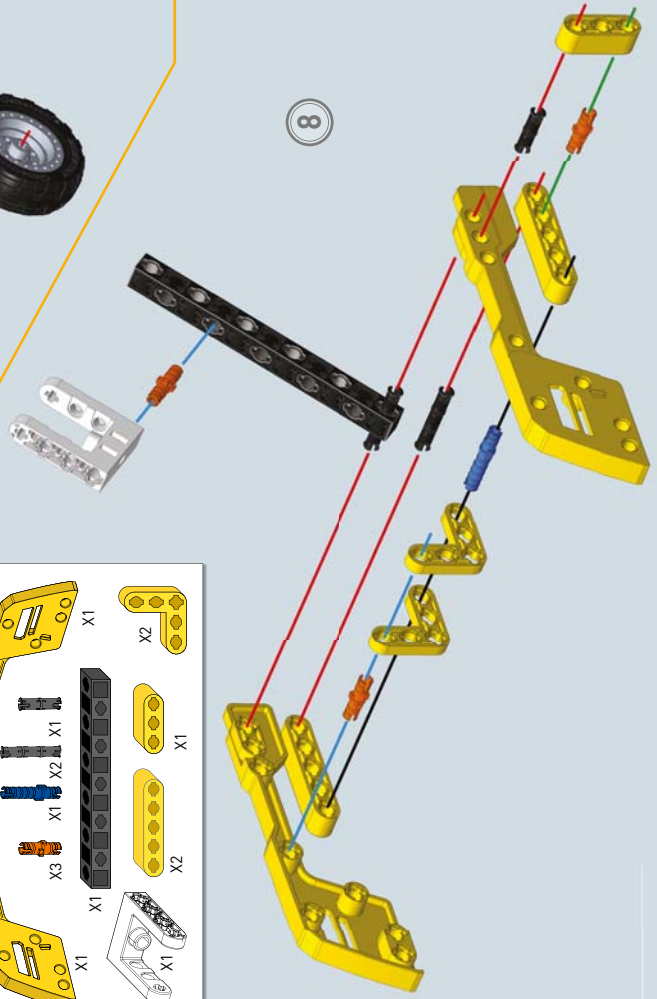

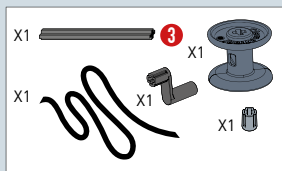

10

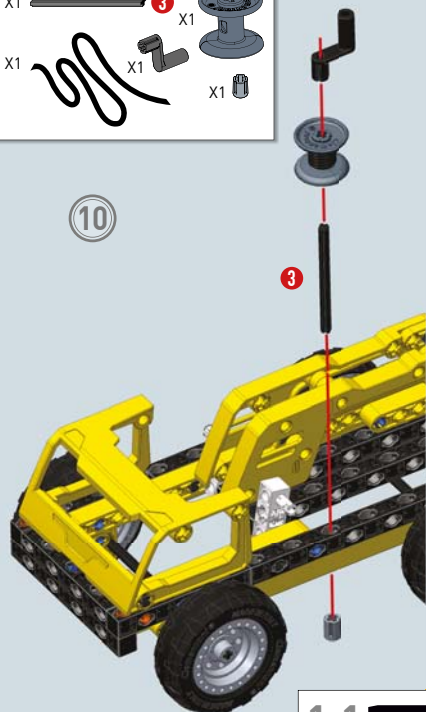

11



Fai passare il filo nei fori come in figura, poi lega il gancio



Modello finale

11 Transpallet



Il transpallet è uno strumento comunemente utilizzato nell'industria per la movimentazione di piccoli carichi poggiati su apposite pedane in legno (pallet). Nella sua forma più semplice le forche vengono sollevate da un pistone idraulico attivato manualmente, pompando l'olio tramite il timone.

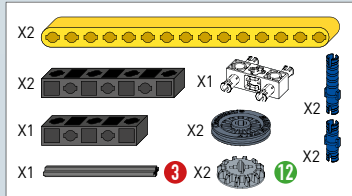
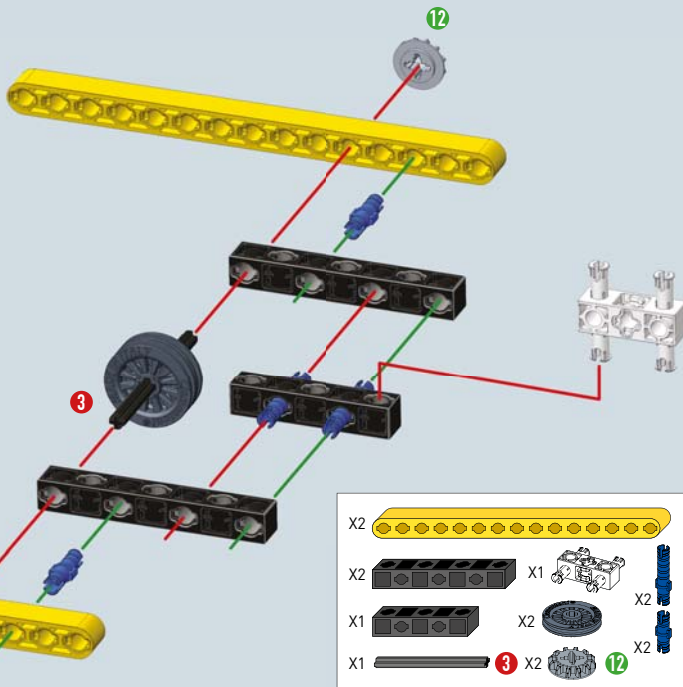

2

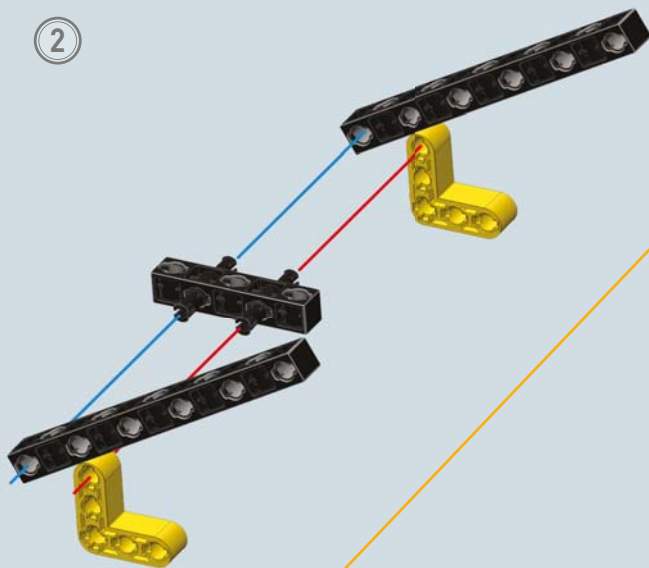

- X2
- X2
- X1

3

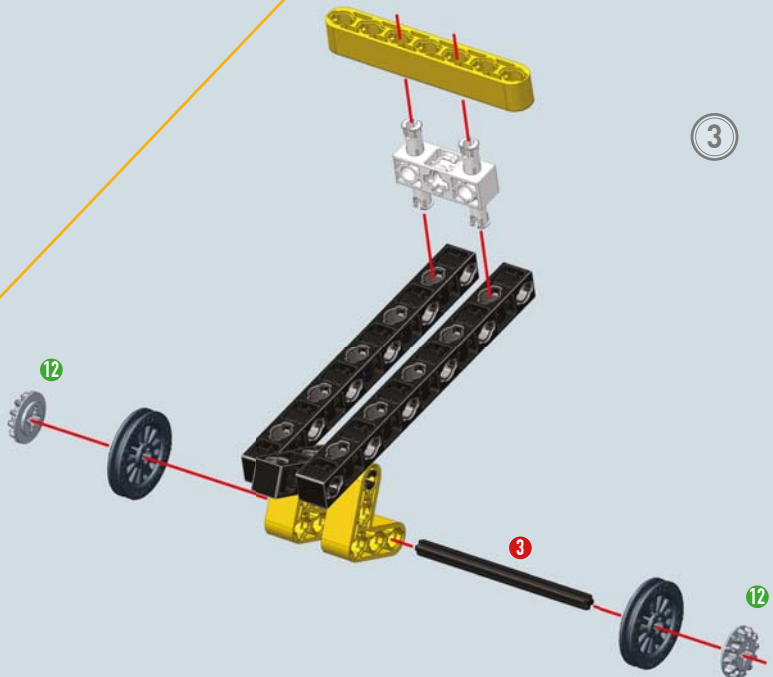

- X1
- X2
- X1
- X2
- X1
-

4

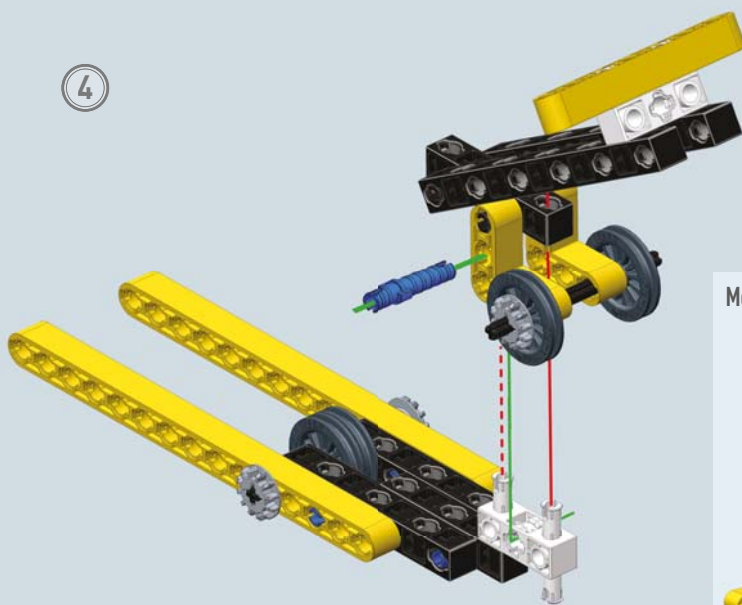

- X1



- 1:1

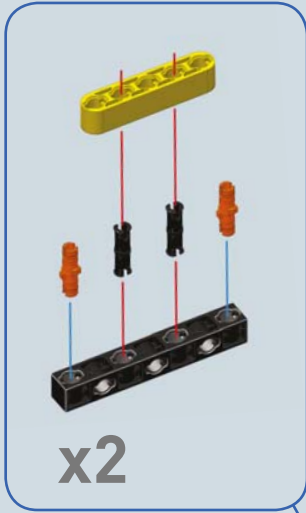

x2

- X2
- X2
- X2
- X8
- X4

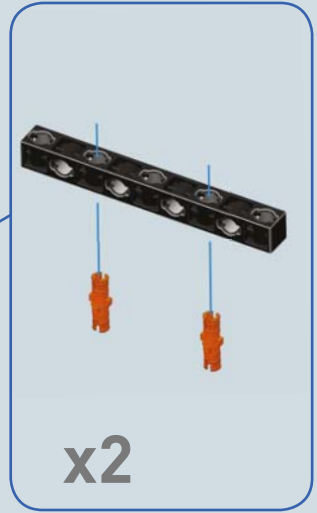

x2

1

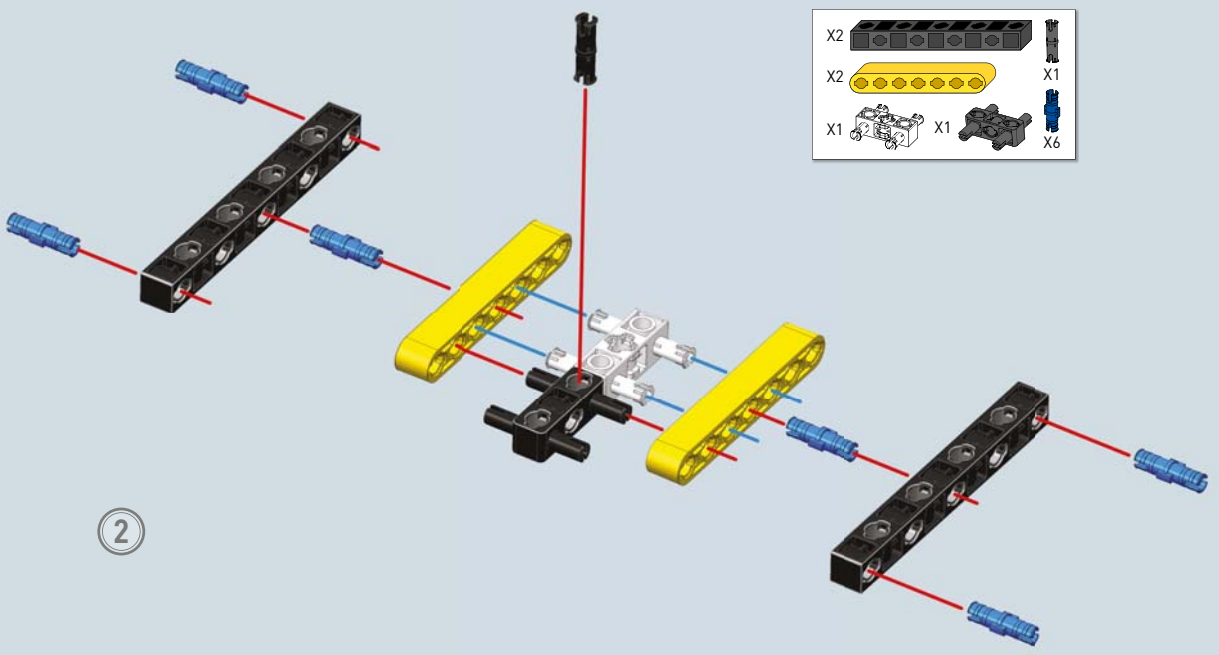
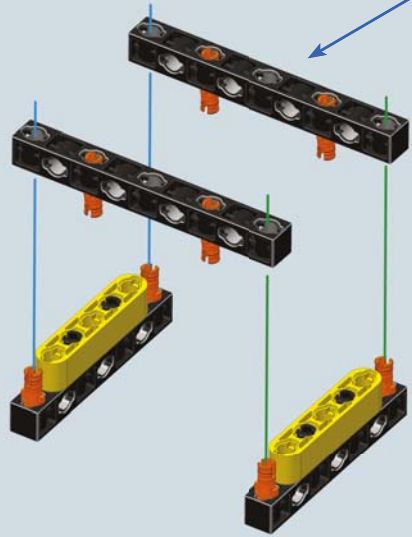

- X2
- X2
- X1
- X1
- X1
- X6

2

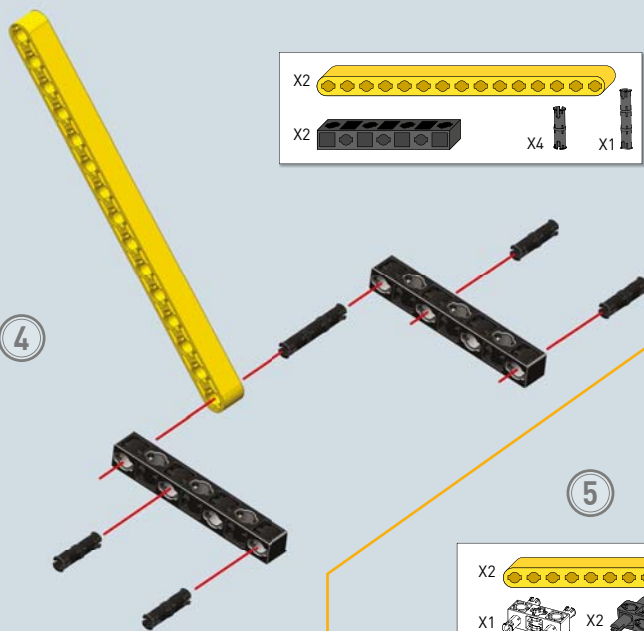
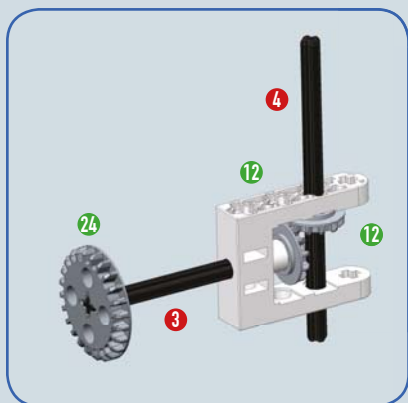
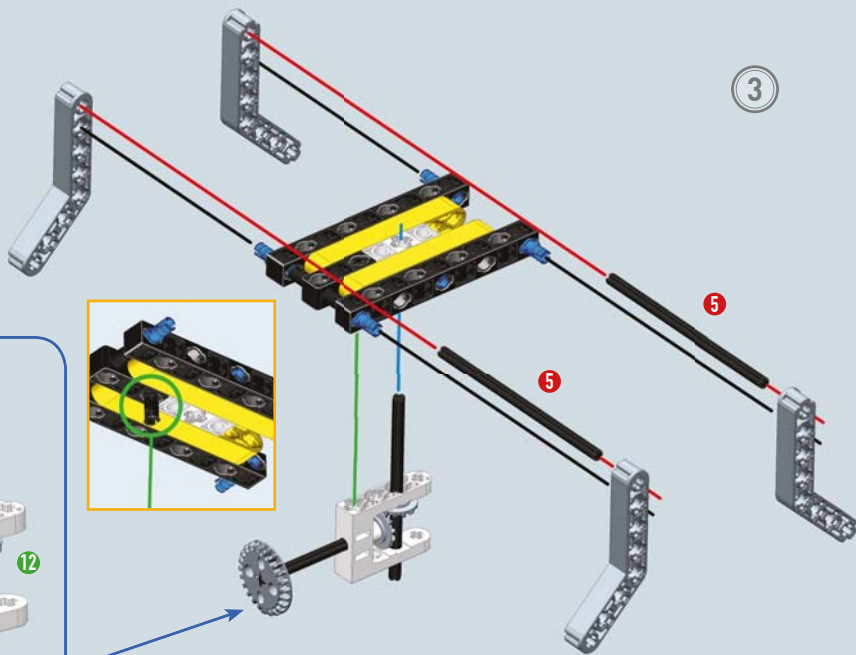
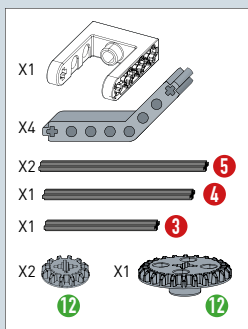

5

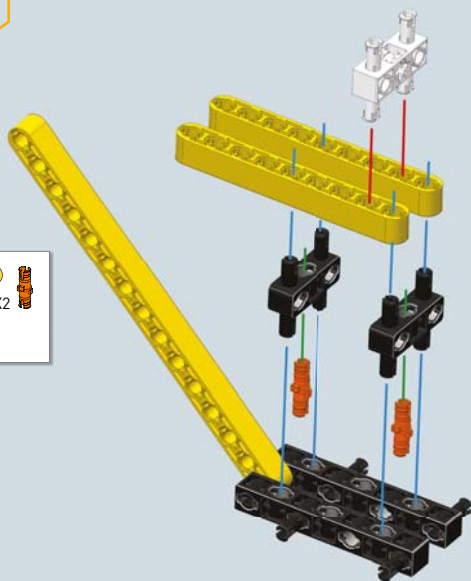
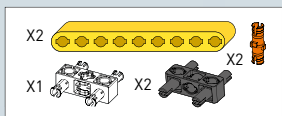

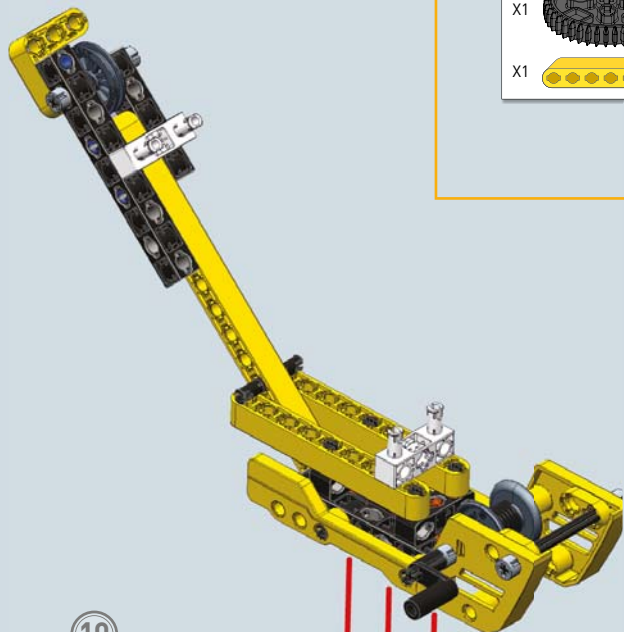

10

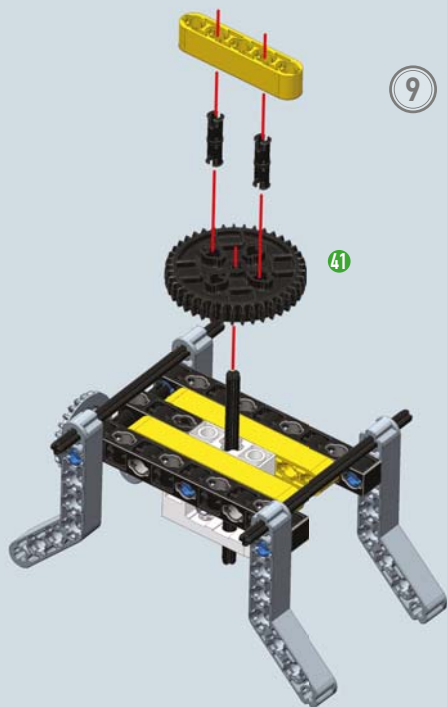
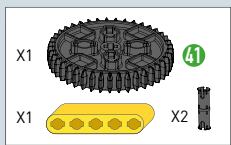

9

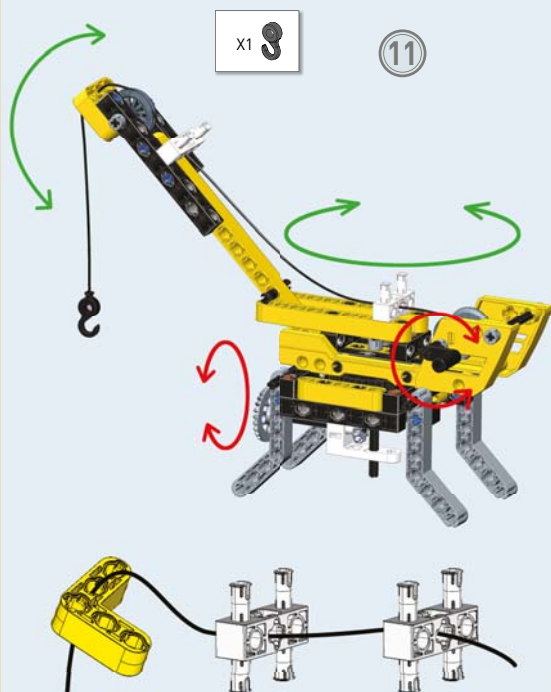
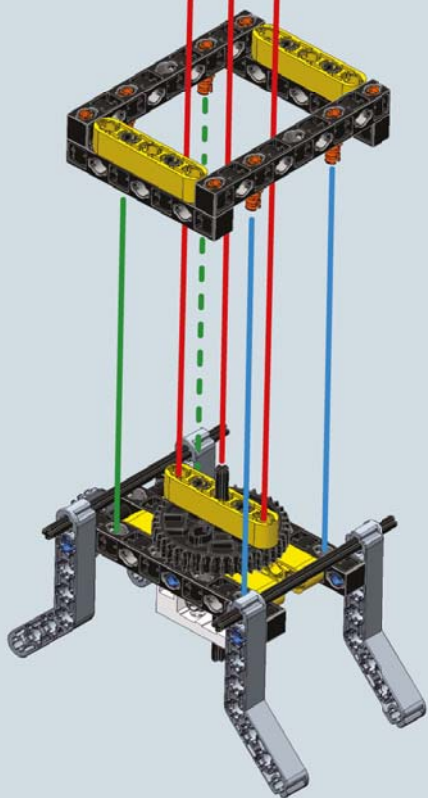

X1 3

11

Modello finale

Fai passare il filo nei fori come in figura, poi lega il gancio.

13 Carrello elevatore con forche

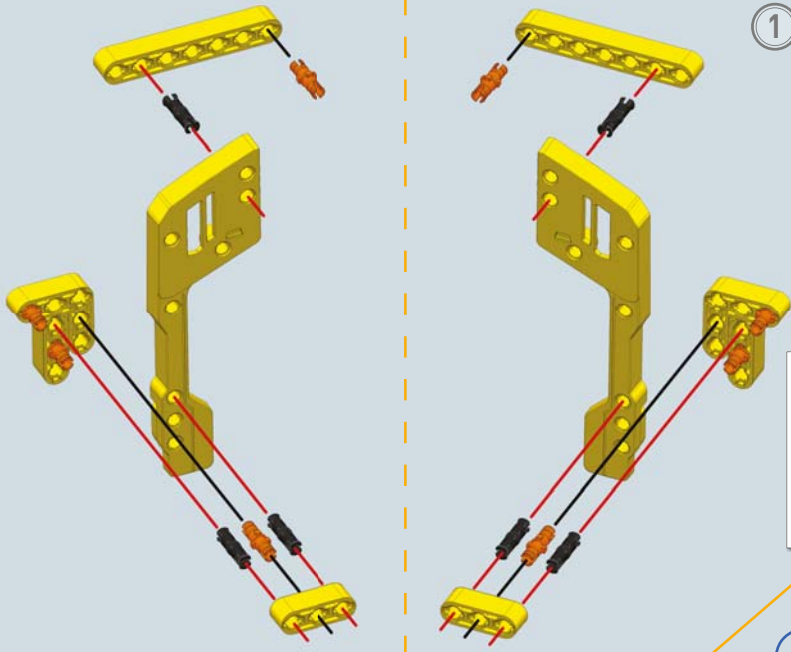

1



Il carrello elevatore industriale è progettato per sollevare e spostare carichi su superfici stabili e lisce. Si muove grazie ad un motore elettrico.

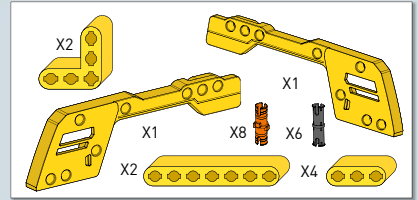

2

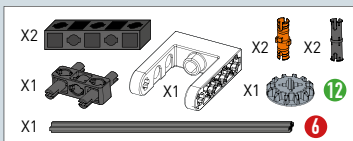
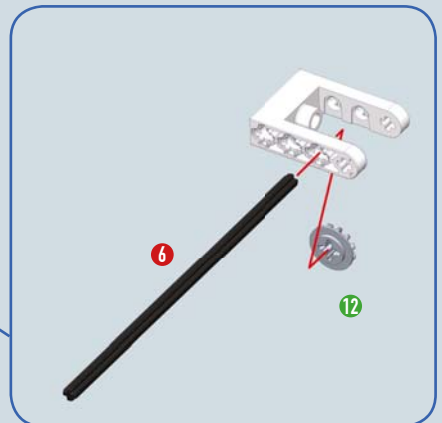
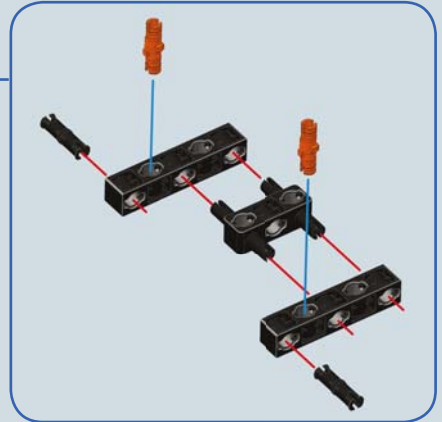
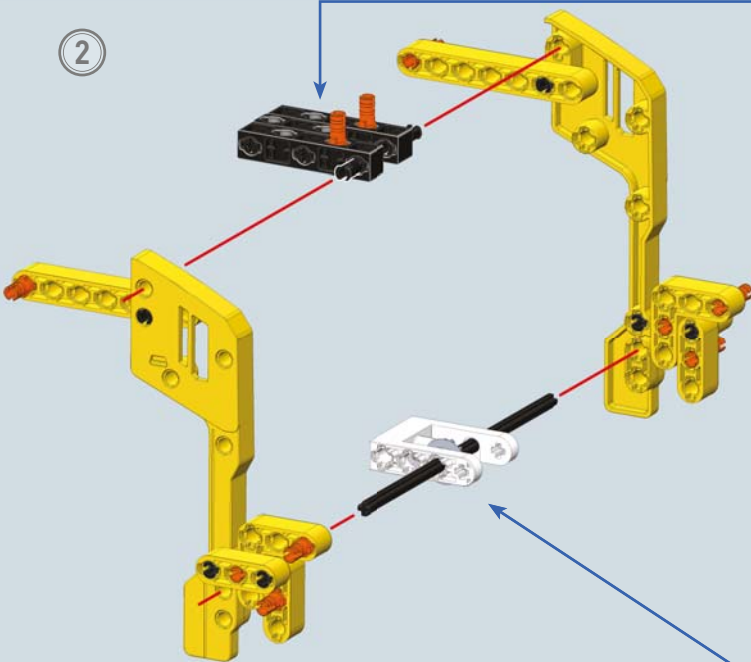

1:1



3

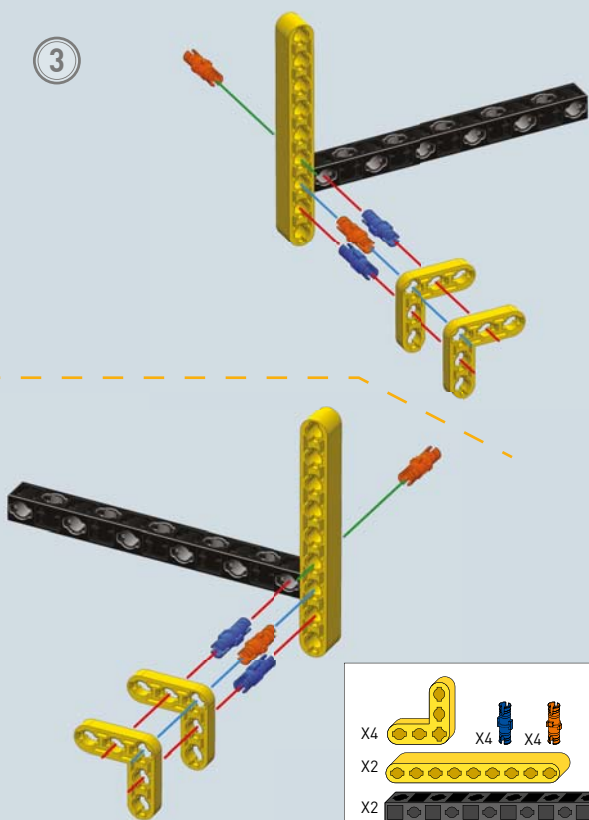

- X4
- X4
- X4
- X2
- X2

4

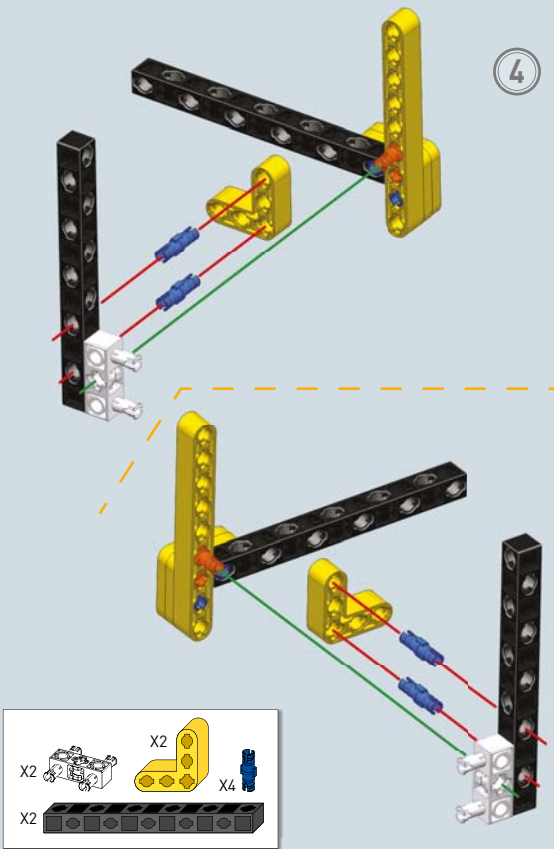

- X2
- X2
- X4
- X2

- X1
- X4

5

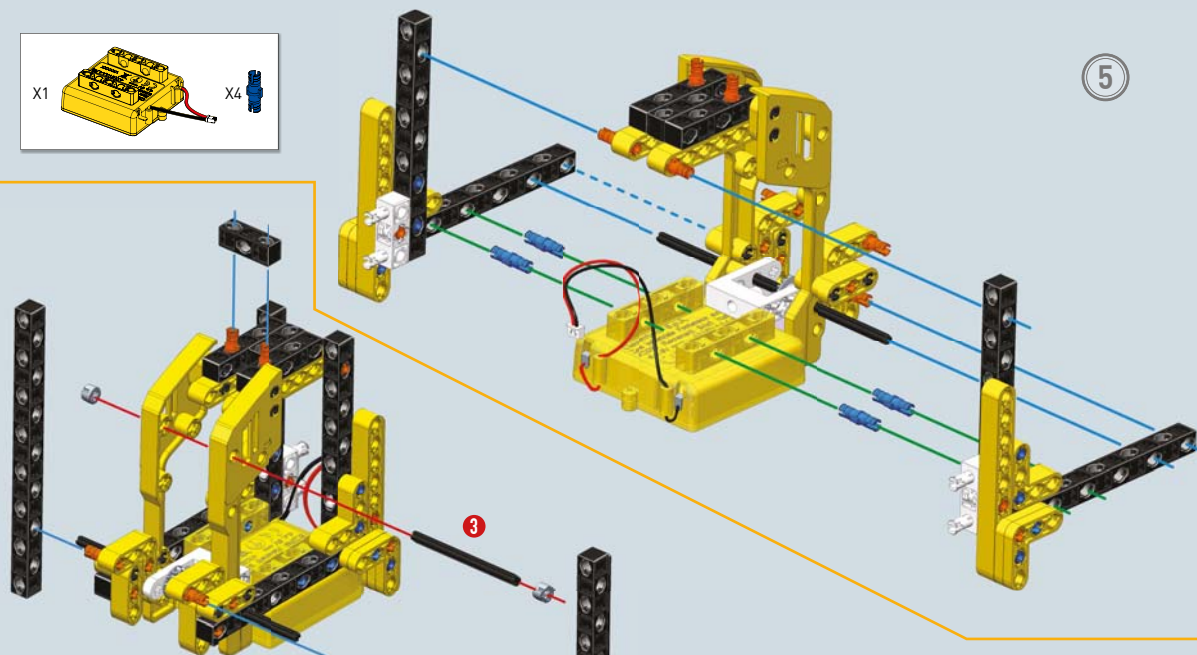

- X2
- X1
- X1
- X2





6

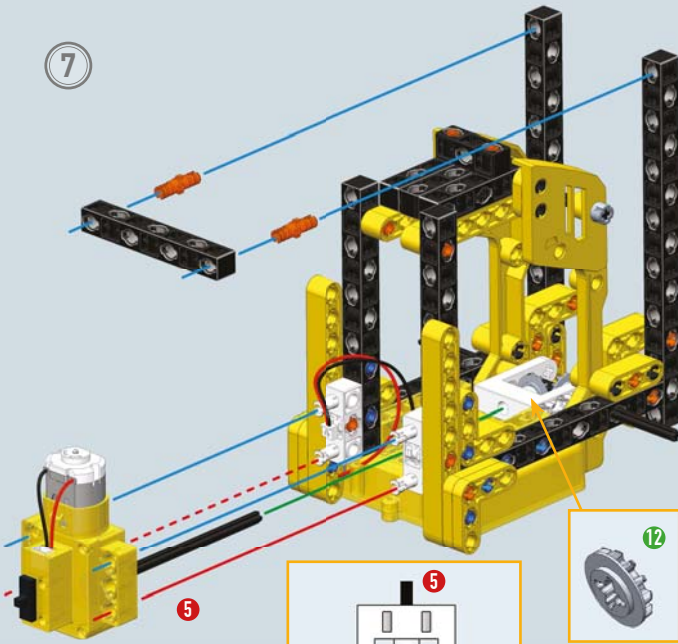

- 1:1

7

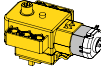

- X1 
- X1  5
- X1 
- X1  12
- X2 

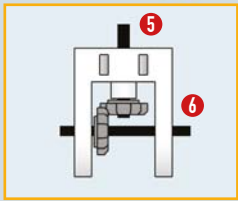



- X2 
- X2 

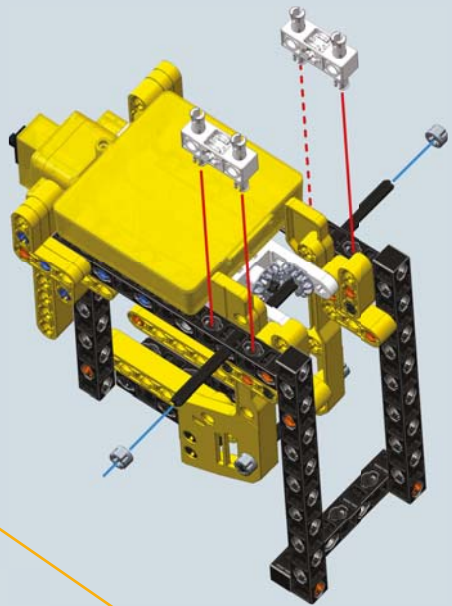

8

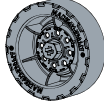

- X2 
- X2 
- X4 
- X2  2

9

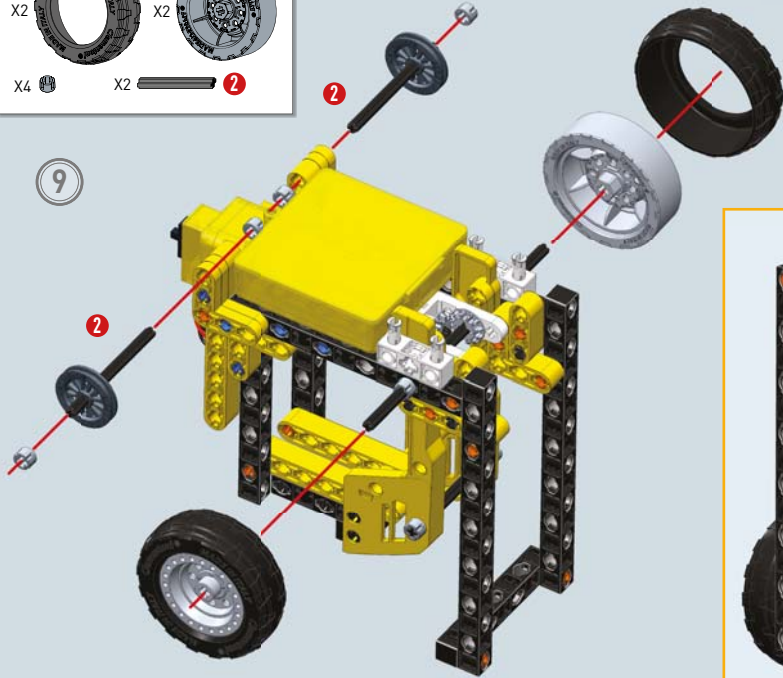

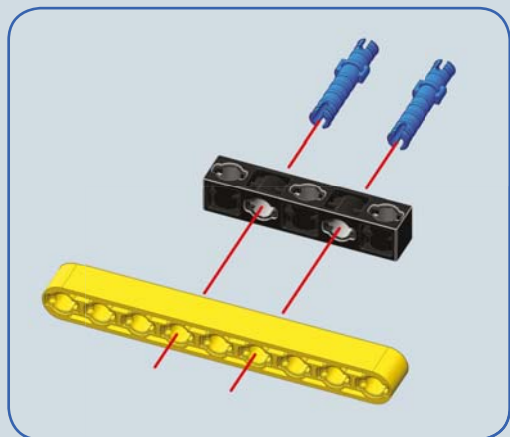

10

- X1
- X2
- X1
- X2
- X2
- X4
- X6
- X2
- X2

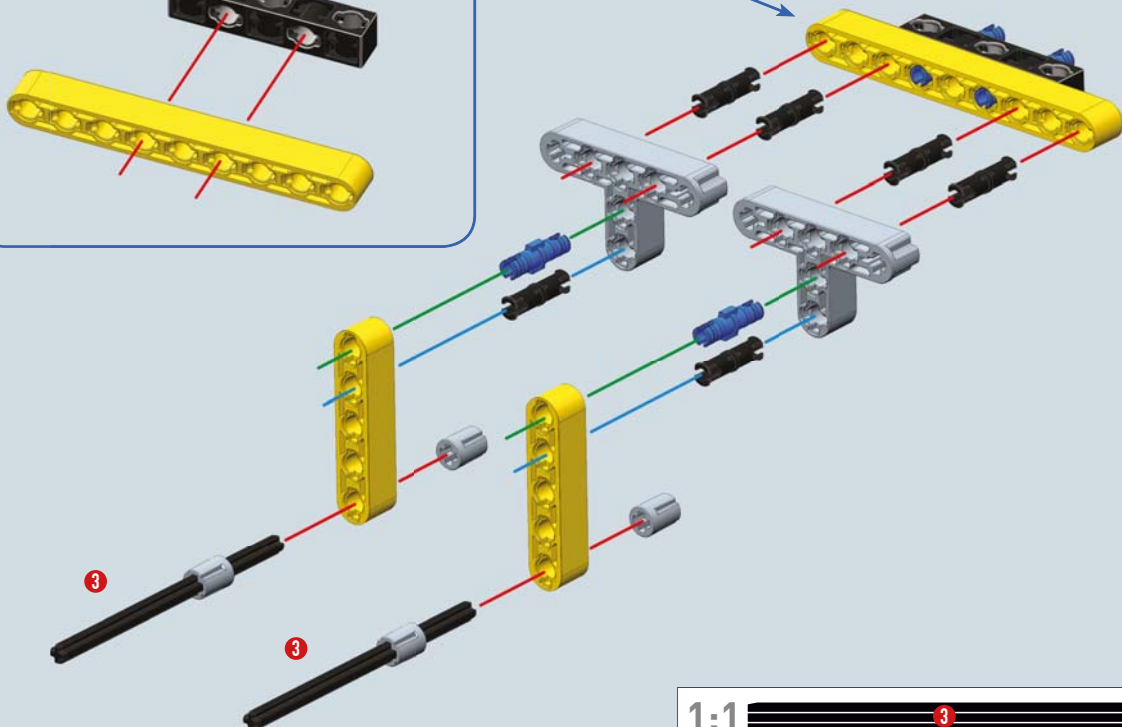

1:1

- X1

11



Modello finale

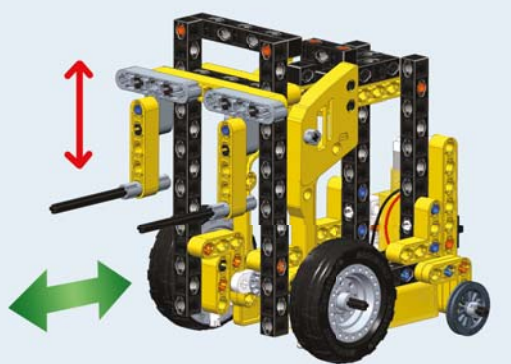

Il carrello elevatore può essere visto come una leva in cui il fulcro si trova sulle ruote anteriori. La resistenza è rappresentata dal peso da sollevare e viene bilanciata dal corpo stesso del carrello elevatore: posteriormente infatti vengono montati elementi molto pesanti, come il motore e soprattutto il vano batterie.

14 Carrello elevatore con pinza per fusti



Realizza prima il carrello elevatore seguendo gli step da 1 a 9 dell'attività 13.

- X4
- X1
- X4
- X1
- X2
- X1
- X1
- X1
- X2
- X2
- X2
- X2

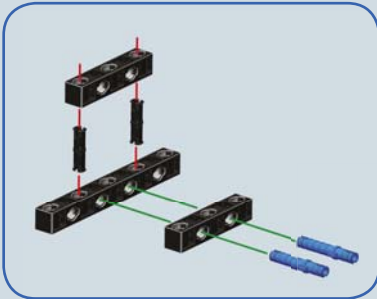
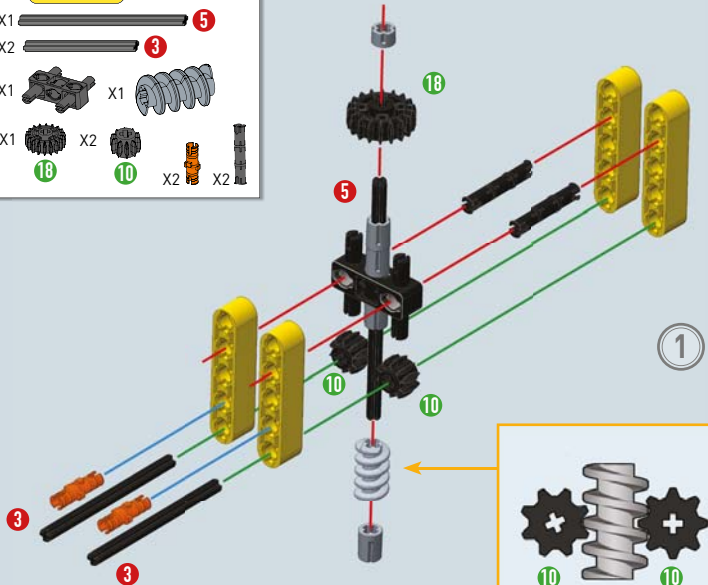

- X1
- X2
- X2
- X4
- X6
- X2
- X2

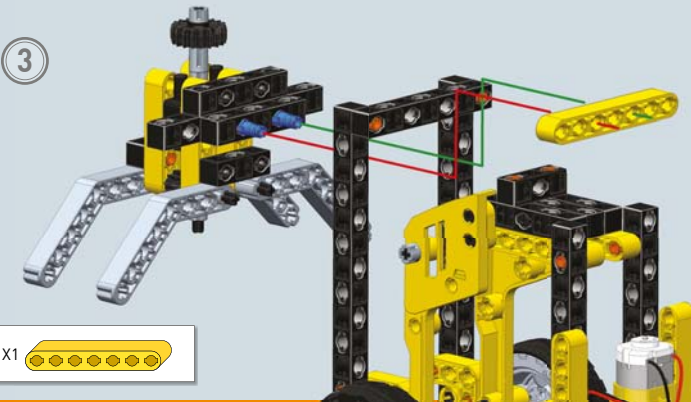
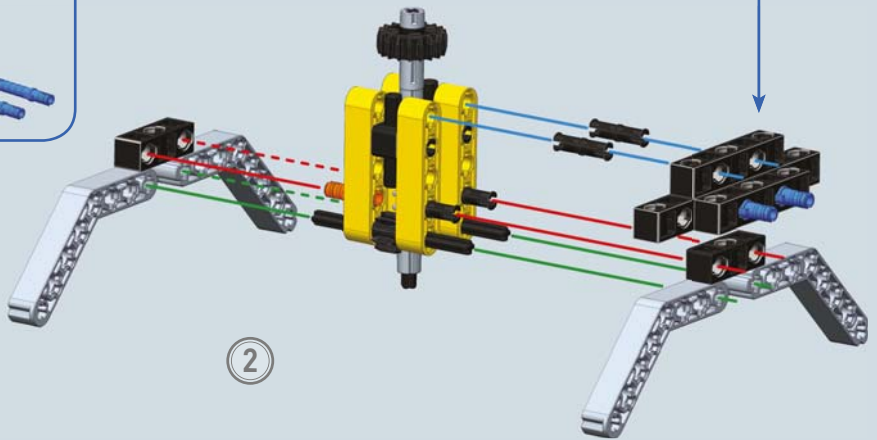

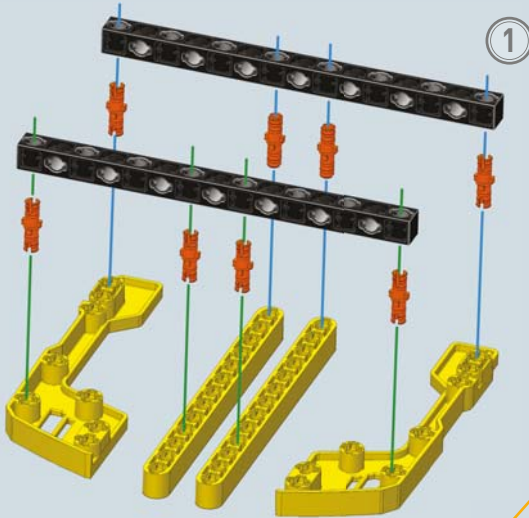

1

- X1 6
- X1 4
- X4 X2 18
- X2 X1 X1 1
- X1 X2 12
- X1 X2 12

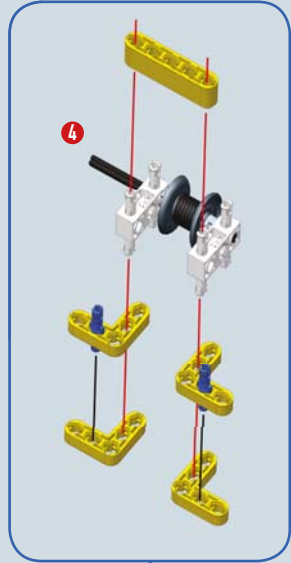

- X2
- X1
- X1
- X8
- X2

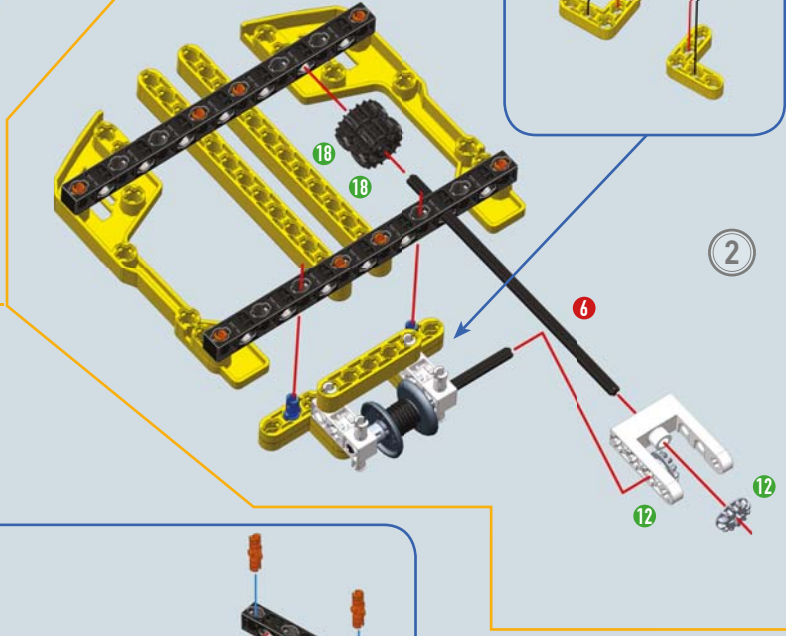

2

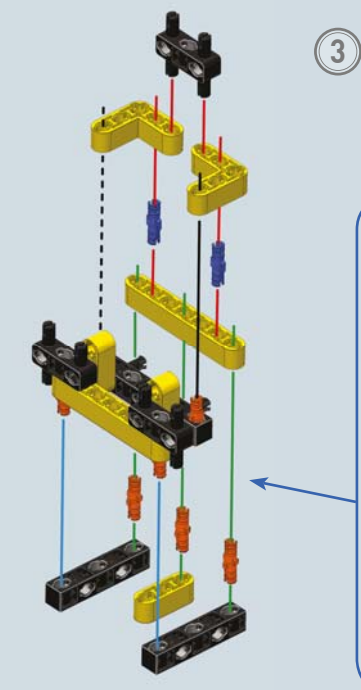

3

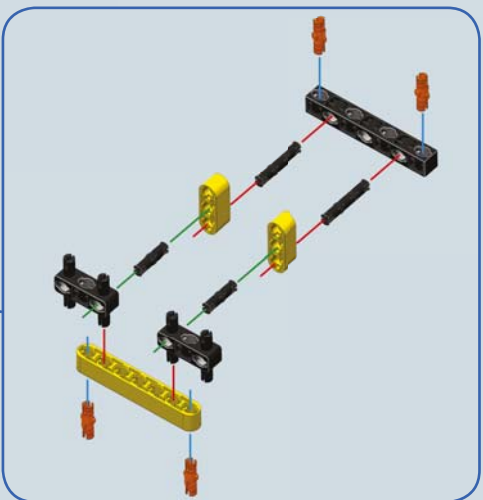

- X1 X3
- X2
- X2
- X3 X2
- X2 X2
- X2 X7



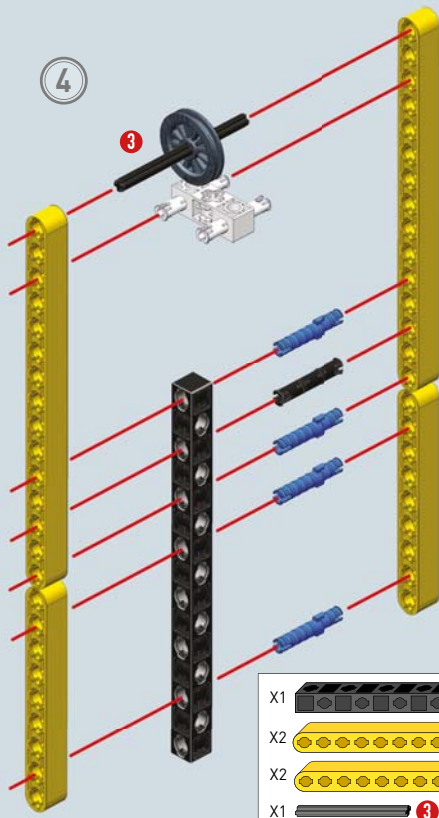

4

3

- X1
- X2
- X2

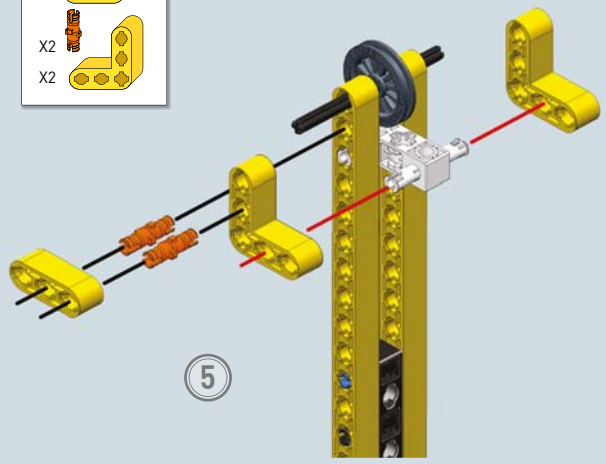

5

- 1:1
- 3

- X1
- X2
- X2
- X1
- X1
- X1
- X1
- X4

Fai passare il filo nei fori come in figura, poi lega il gancio.

Modello finale

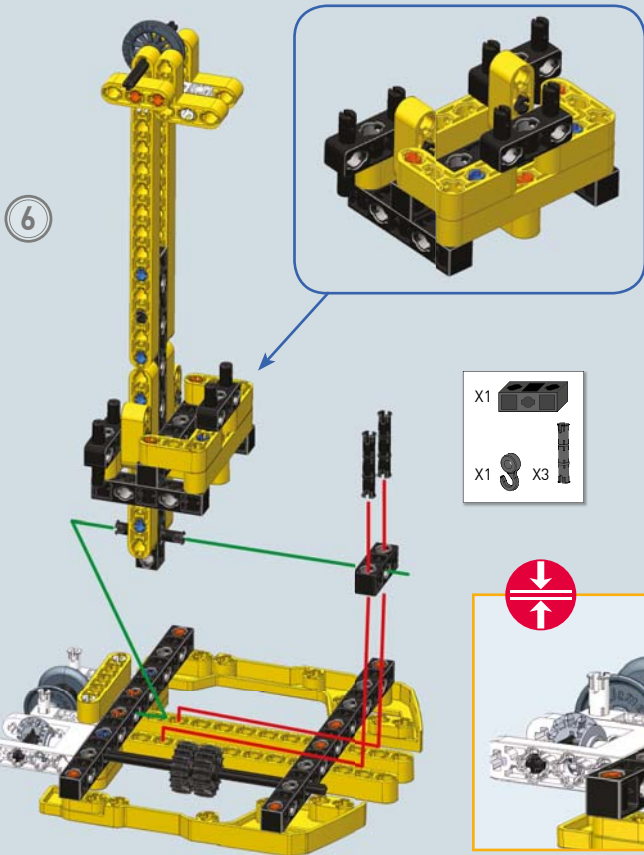

6

- X1
- X1
- X3

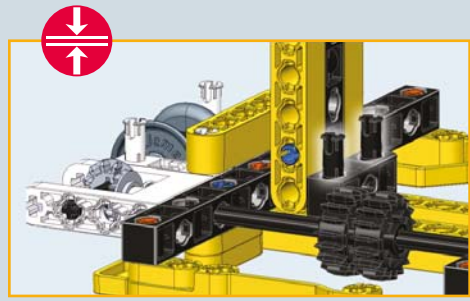

In questa attività costruirai la torre della gru che ti servirà, nelle attività successive, per realizzare una gru tradizionale o una gru con braccio a volata variabile.

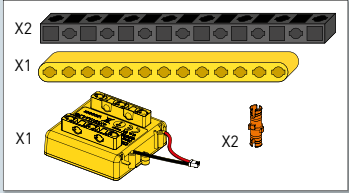
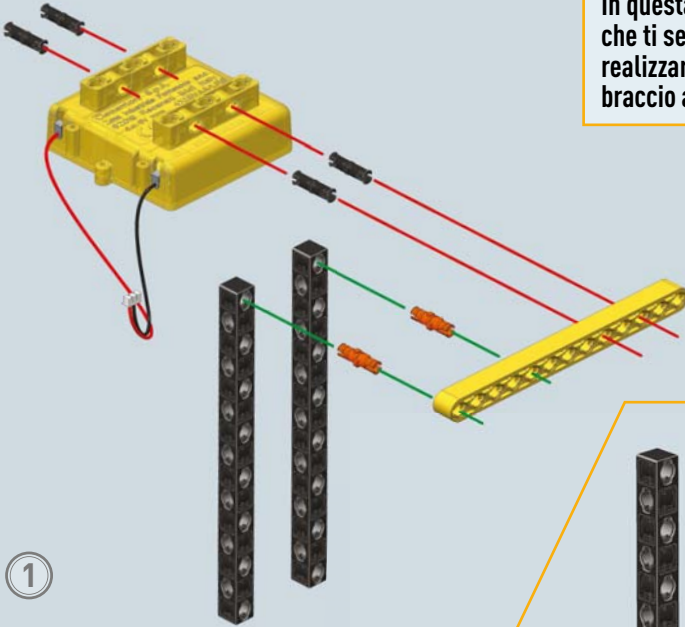

1

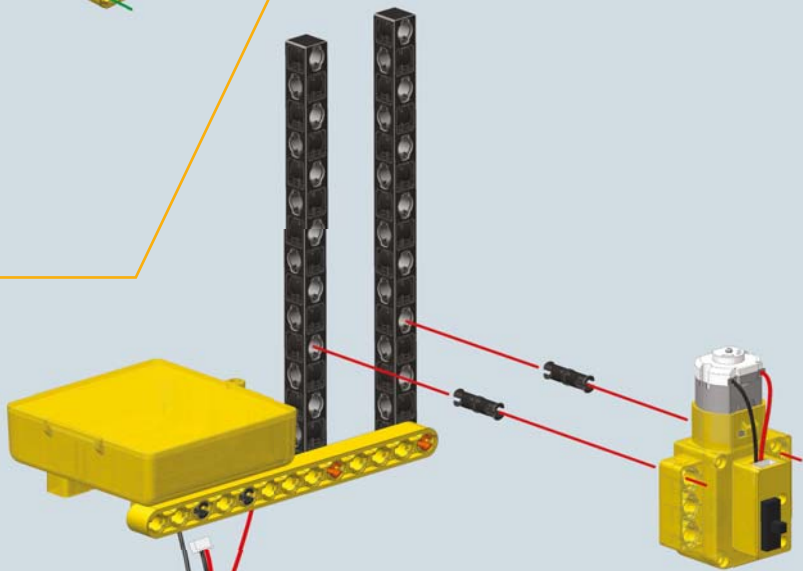
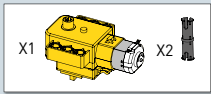

2

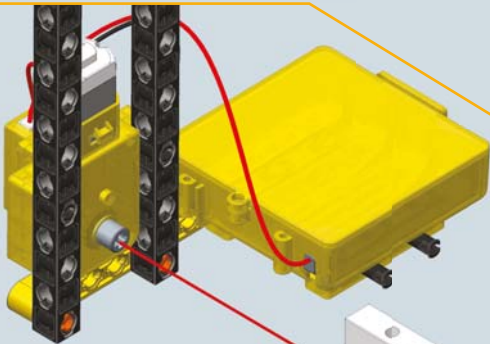

3

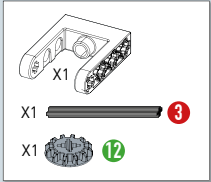

Connetti il vano batterie al motore



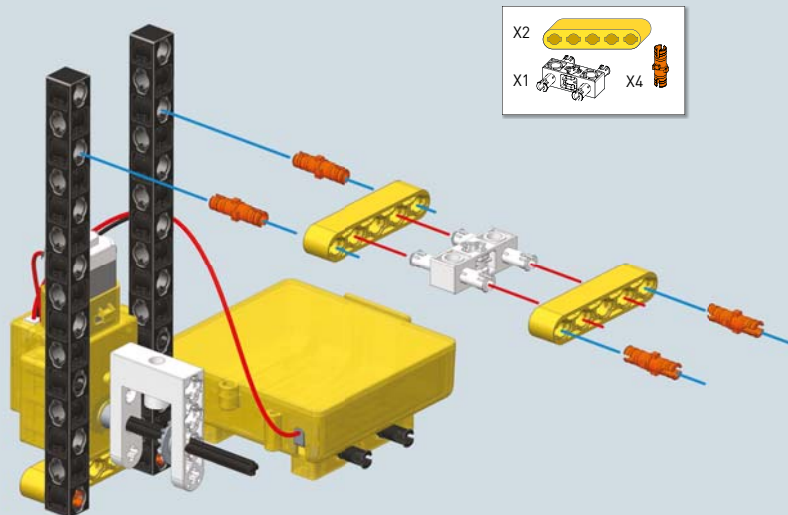

- X2
- X1
- X4

4



La torre costituisce l'impalcatura verticale della gru. Può innalzarsi fino ad un'altezza di 80-100 m e viene stabilizzata alla base con imponenti zavorre (di solito lastre di cemento impilate).

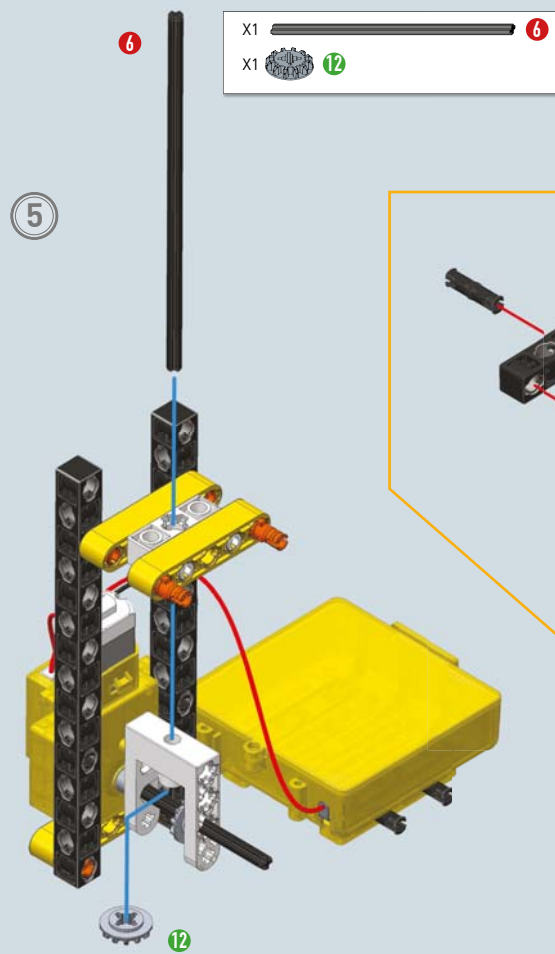

- X1
- X1

5

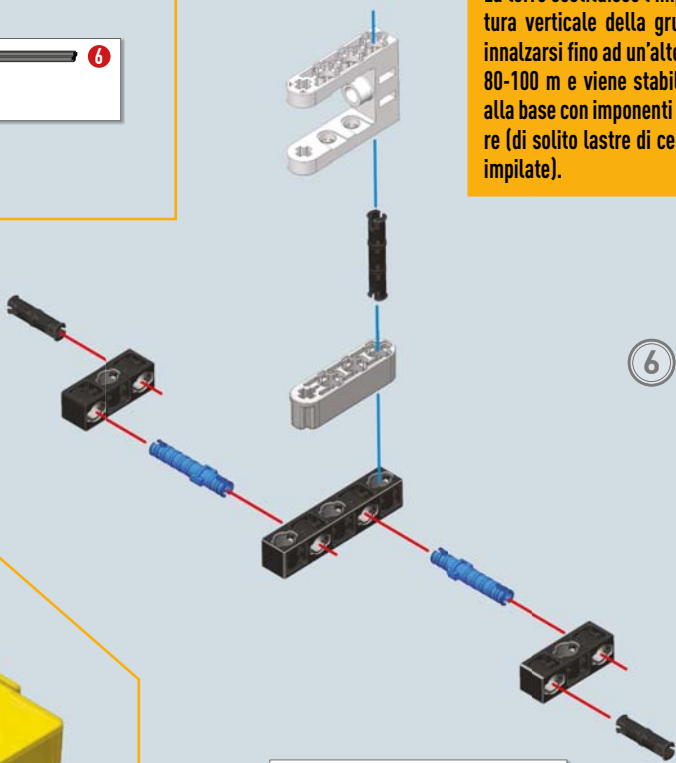

6

- X1
- X2
- X1
- X1
- X2
- X1
- X2





7

Per assemblare il giunto cardanico controlla le istruzioni a pag. 3

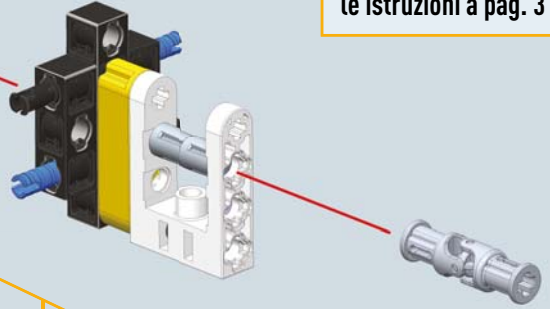
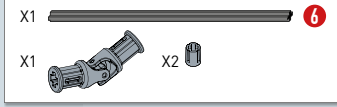

8

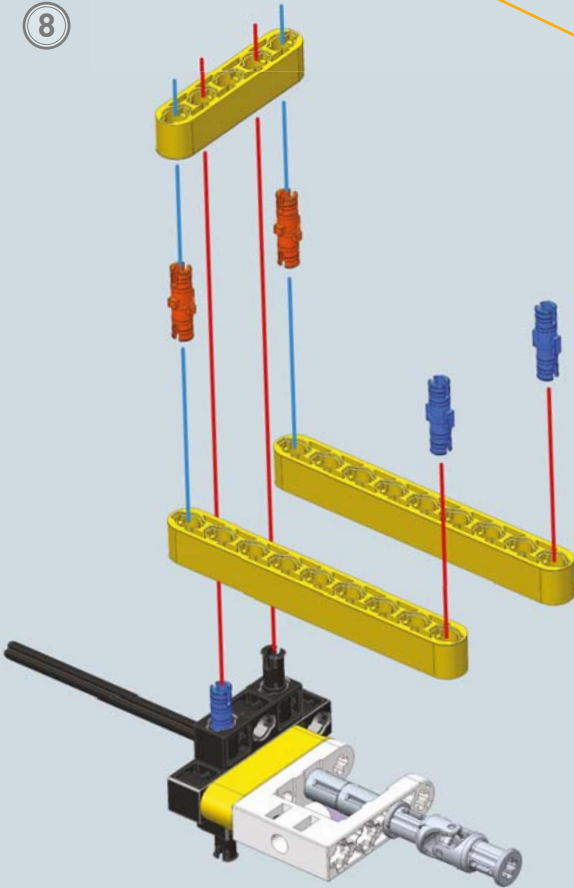

9

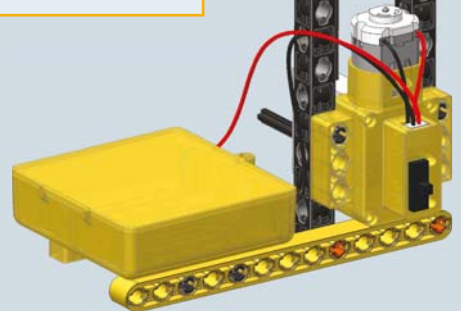
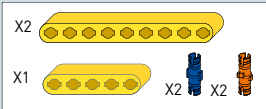
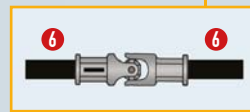

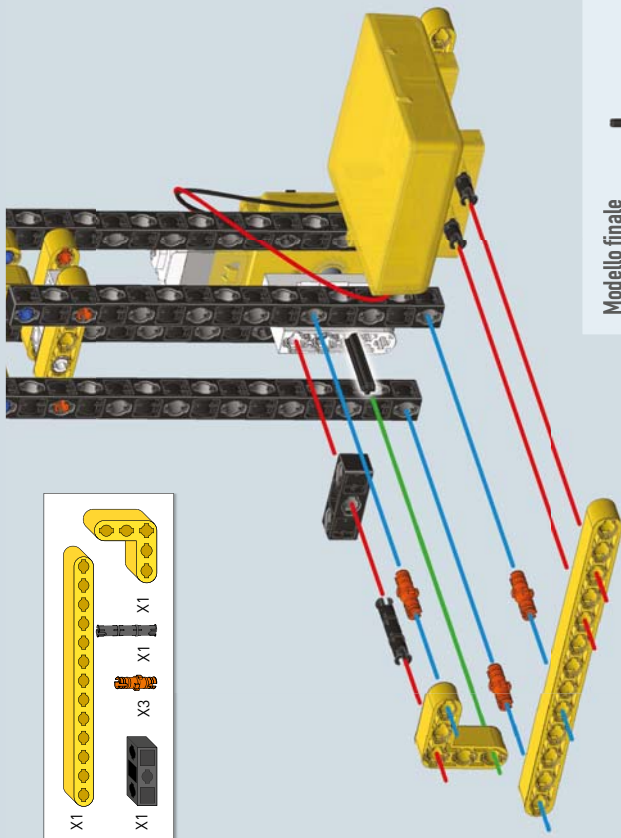

11

Spostando il tasto dello switch puoi azionare il motore e regolare il verso di rotazione. Tramite i meccanismi della torre trasferiremo la rotazione dal motore, alla base della gru, alla cima, dove costruiremo il braccio.

Modello finale

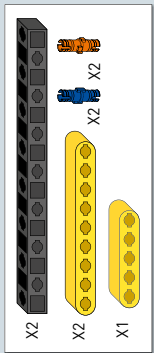
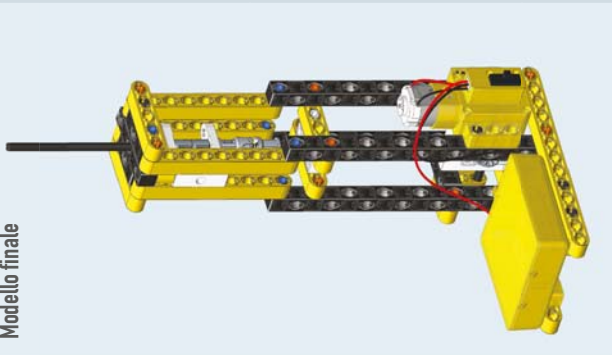

10

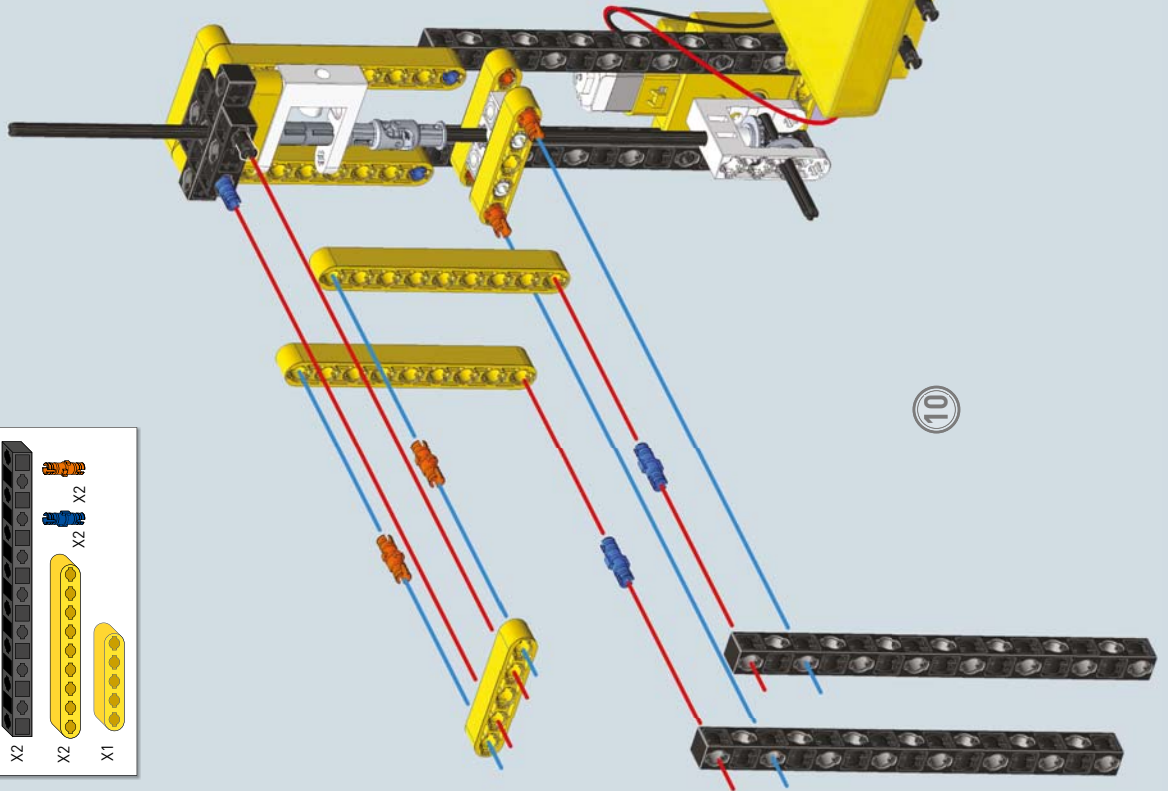



1

X1				
X1		X1		X1
X1		2		

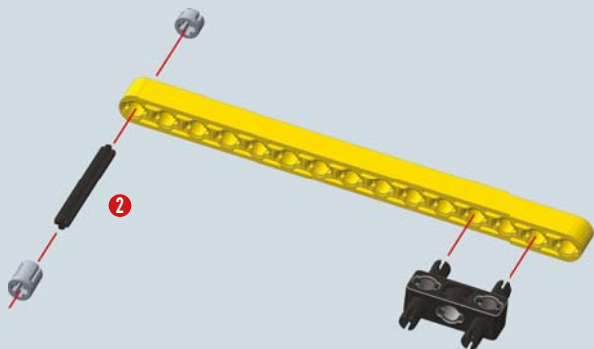

Il braccio orizzontale rotante monta da un lato il gancio sospeso per il sollevamento del materiale e dall'altro lato il contrappeso. La cabina dell'operatore si trova al centro.

2

1

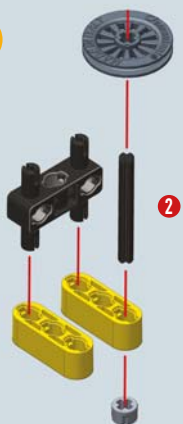

2

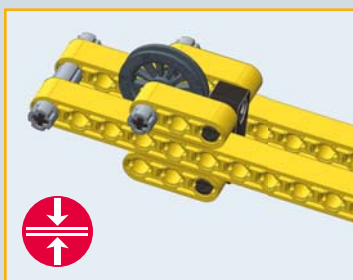
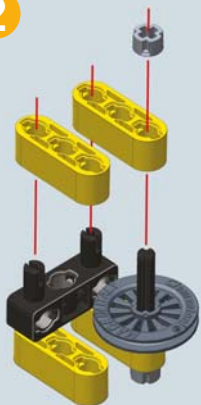

X1				
X4		X1		X1
X1		X3		X1

1:1		2
-----	--	---



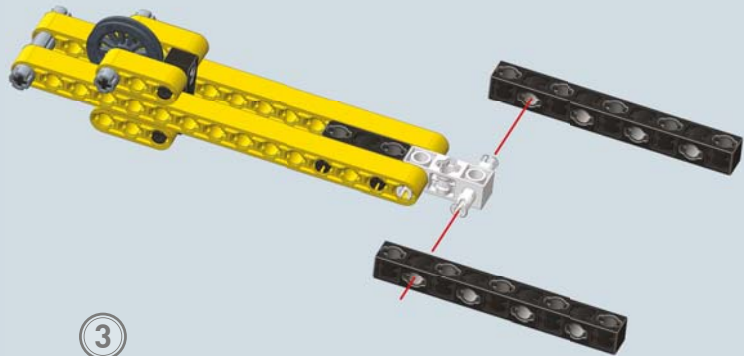
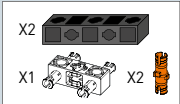

3

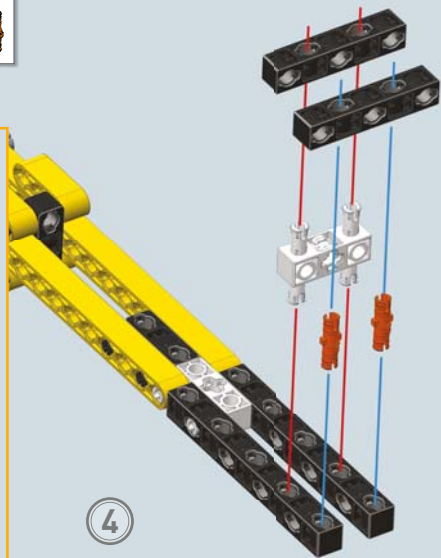

4

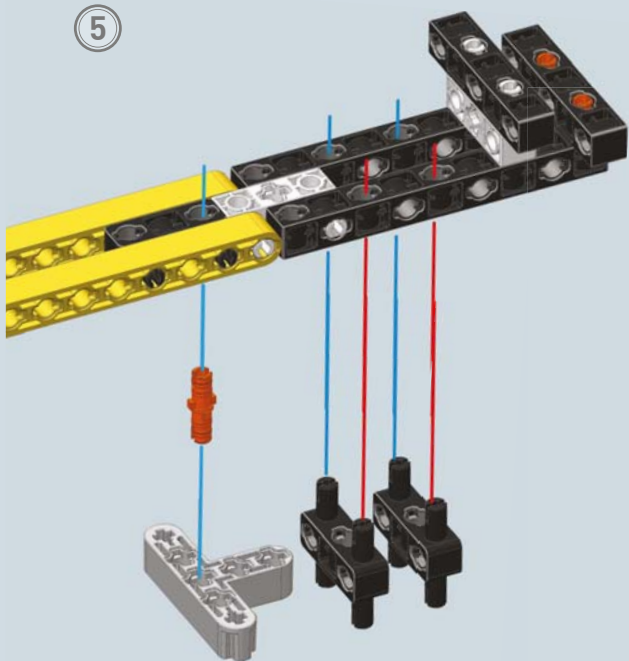
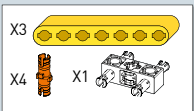

5

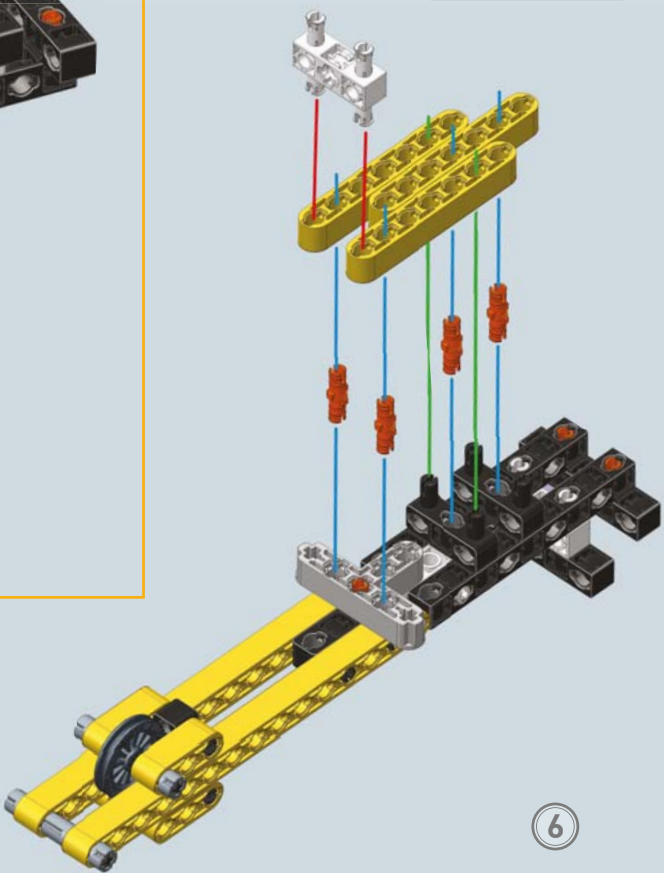
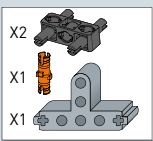

6

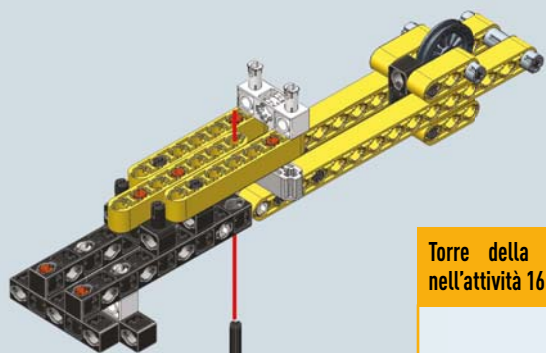

7

Torre della gru costruita nell'attività 16

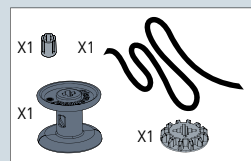

Lega il filo al rocchetto

8

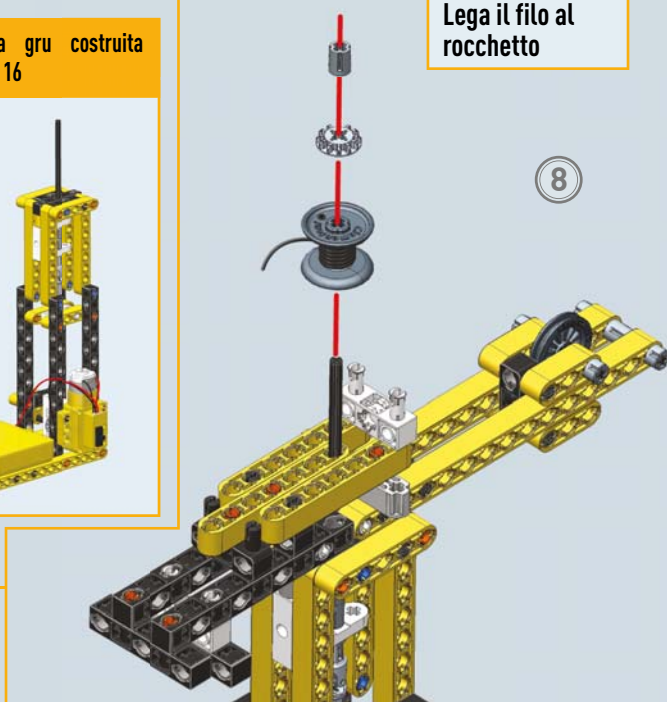

Fai passare il filo nei due fori della barra con chiodini e della barra nera, poi nella scanalatura (gola) della puleggia. Infine lega il gancio.

9

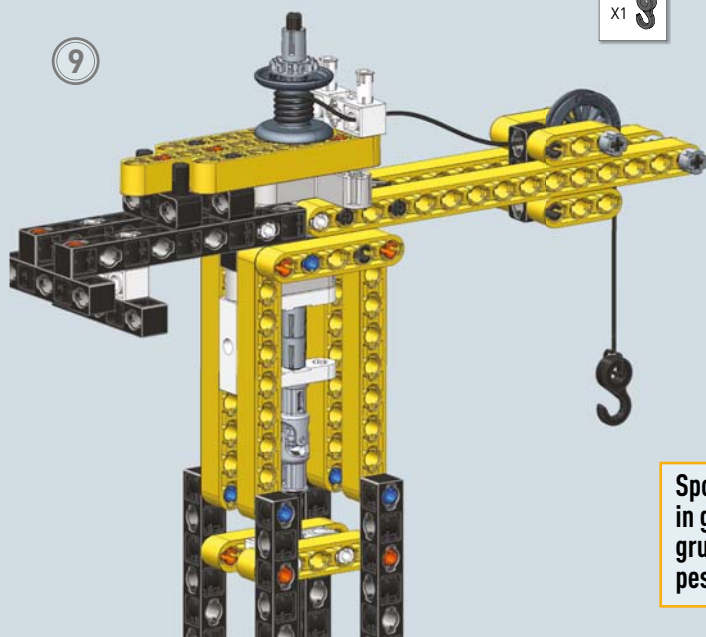

Modello finale

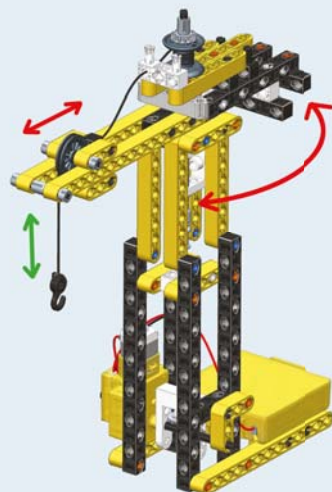

Spostando la carrucola vicino al rocchetto, sarai in grado di sollevare più peso, senza sbilanciare la gru. Più allontani la carrucola dal rocchetto, meno peso potrai sollevare senza sbilanciarla.

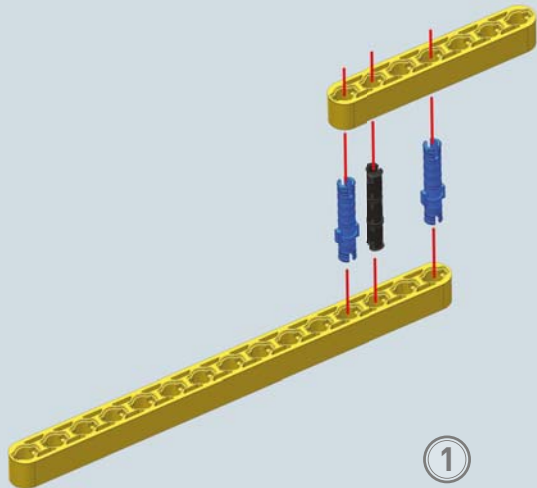
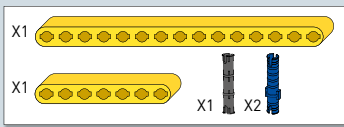

2

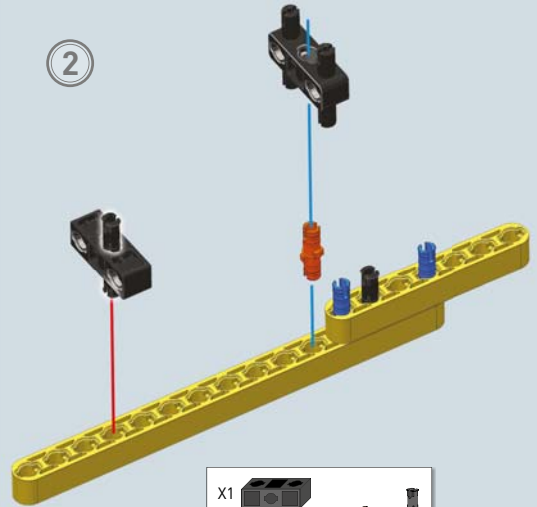

3

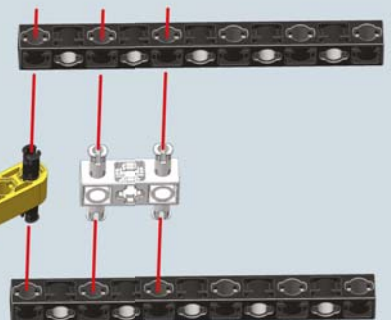
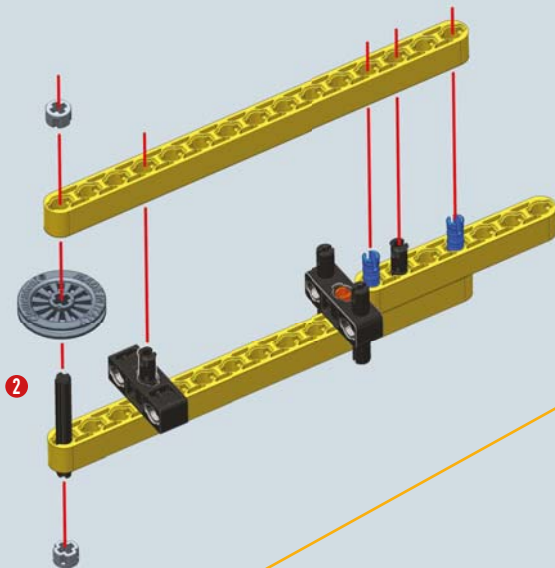
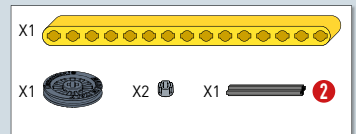

4

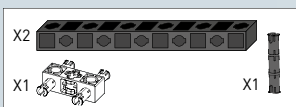

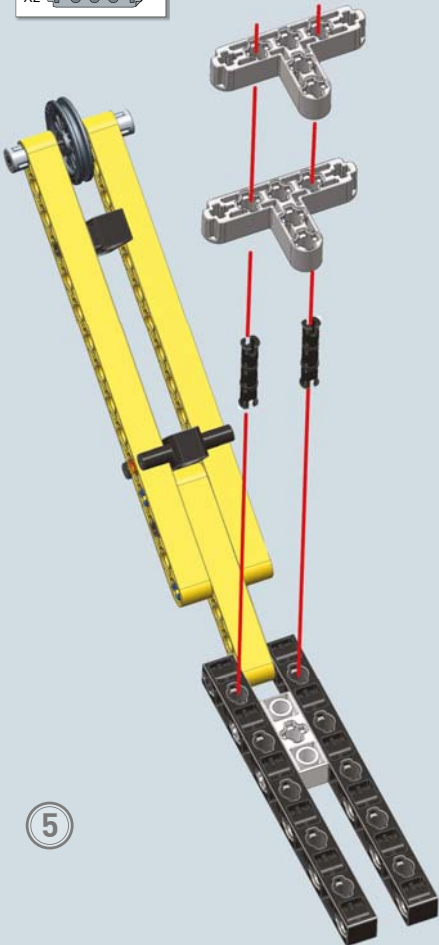
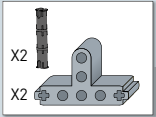

5

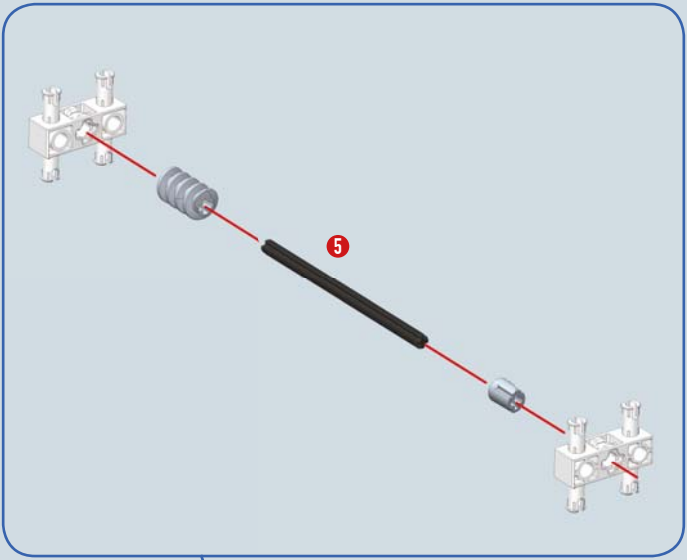

5

6

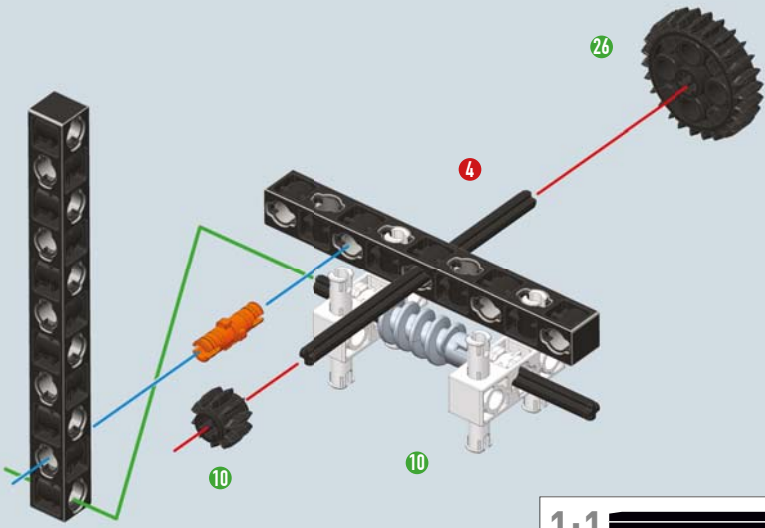
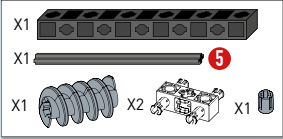
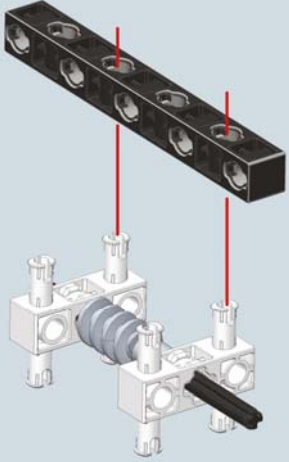

7

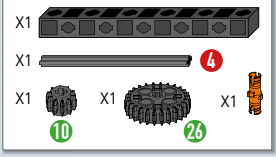

8

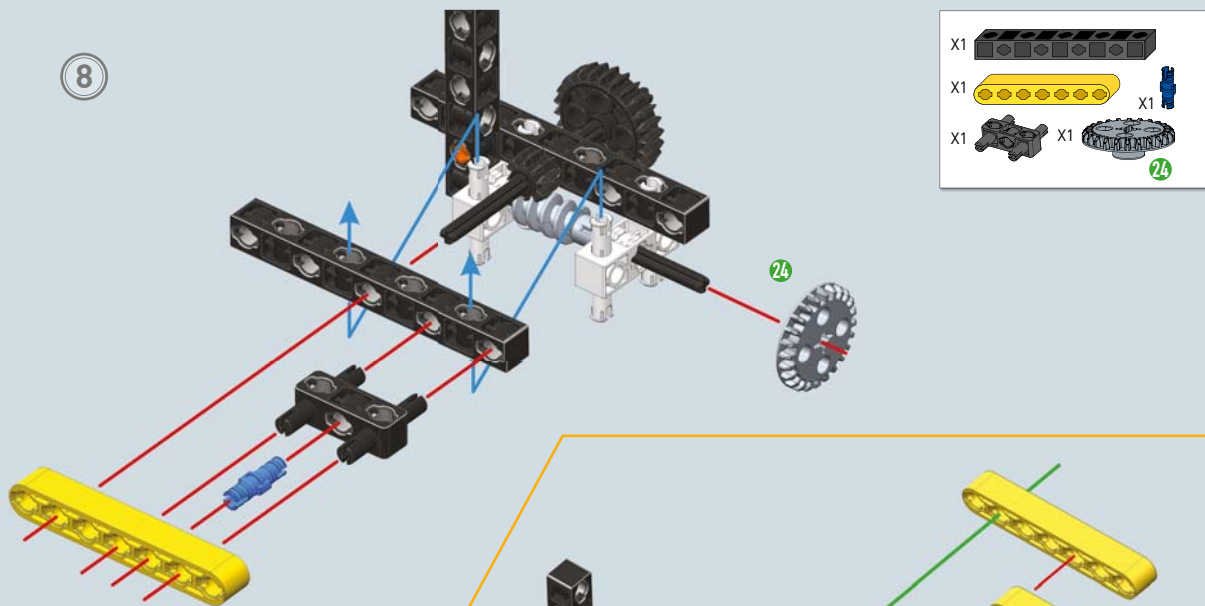

- X1
- X1
- X1
- X1
- X1
- X1

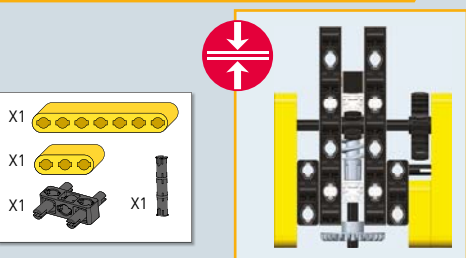

- X1
- X1
- X1
- X1

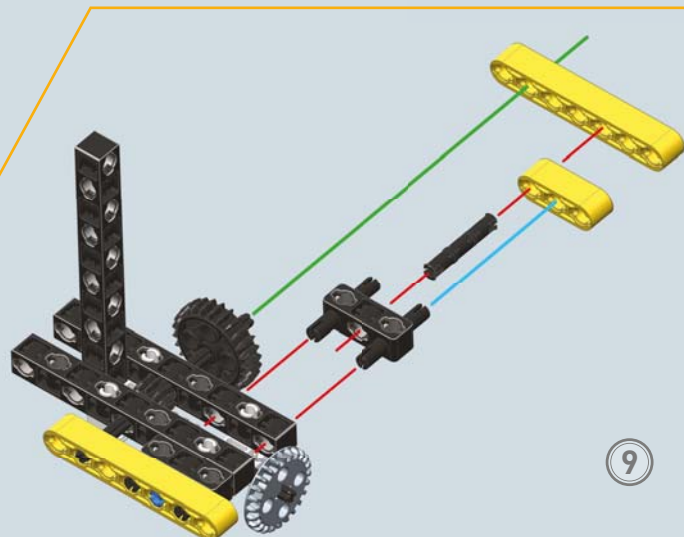

9



X1

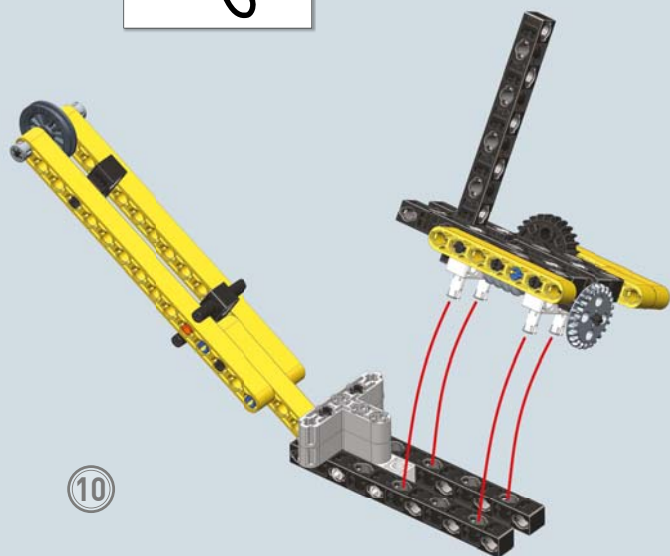

10

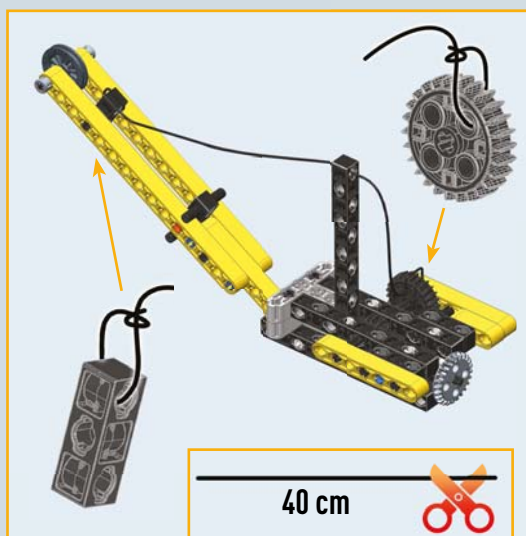

40 cm



Facendoti aiutare da un adulto, taglia il filo ad una lunghezza di 40cm. Legane un capo alla ruota 26 denti, poi fai passare il filo nell'ultimo foro della barra da 11 e infine lega l'altro capo al foro della barra da 3.

11

Torre della gru costruita nell'attività 16

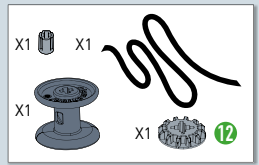
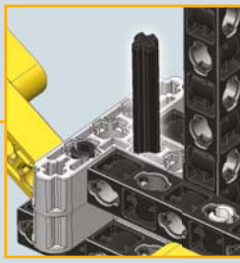

Leγα il filo rimanente sul rocchetto

12

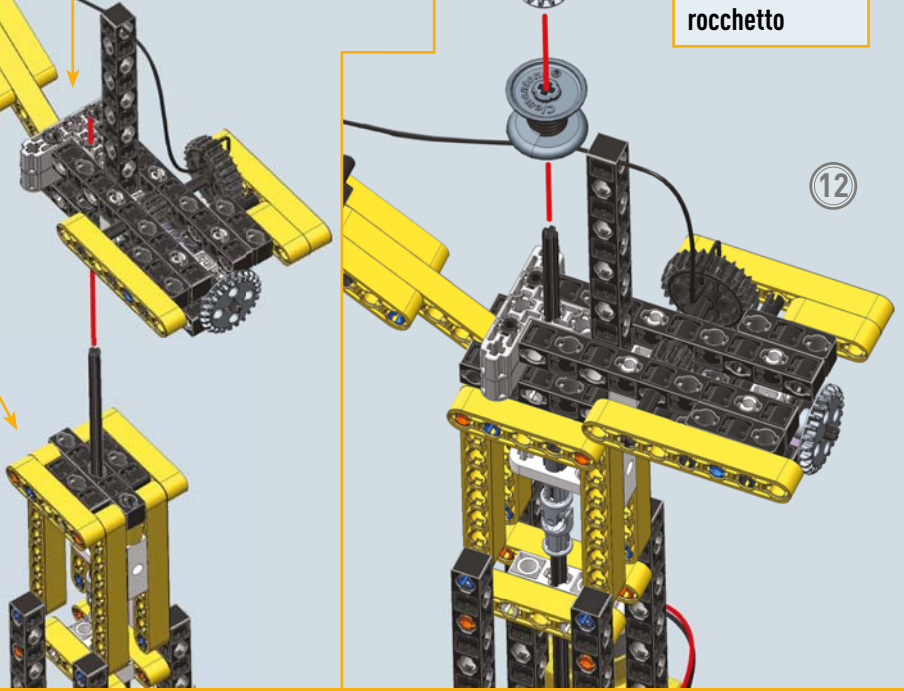

13



Fai passare il filo nel foro della barra con perni e poi nel foro della barra da 3, infine nella scanalatura (gola) della puleggia. Lega poi il gancio.

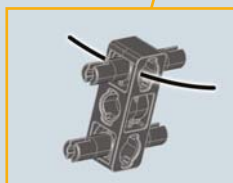
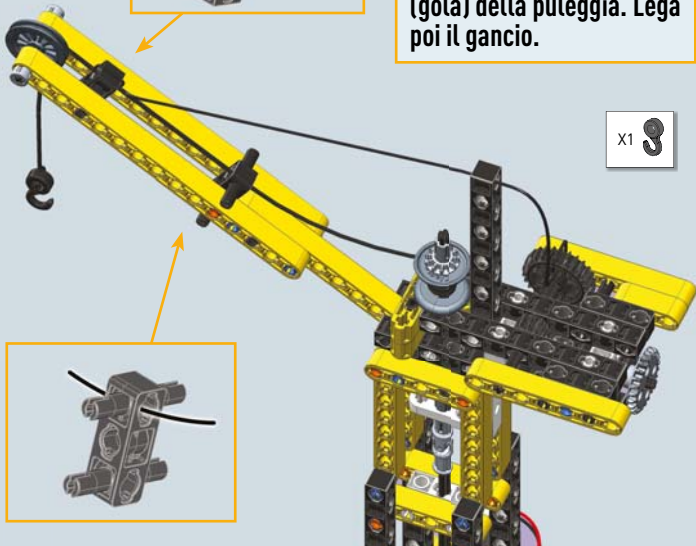

Modello finale

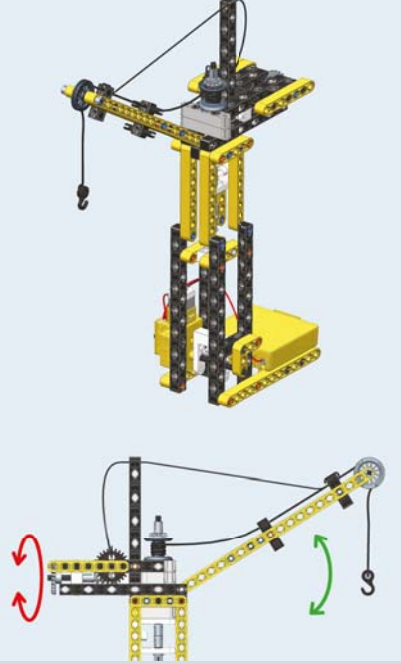



L'autogru o gru mobile è una gru in grado di spostarsi, con o senza carico, su percorsi che non richiedono rotaie. Il grande braccio telescopico della gru viene solitamente montato su di un veicolo gommato che, a seconda delle dimensioni può avere fino a 16 ruote.

1

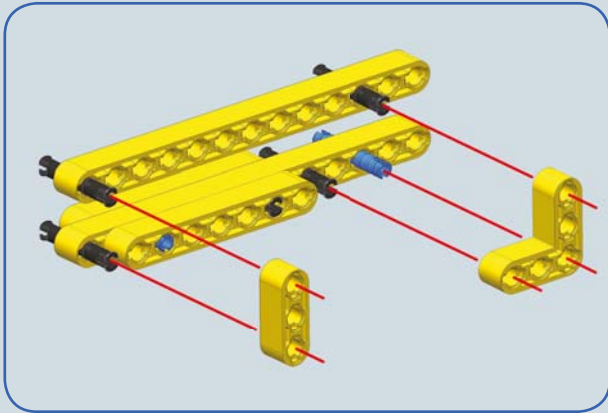
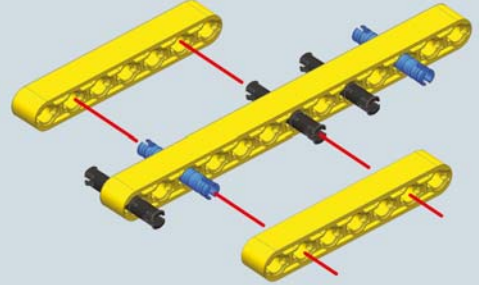
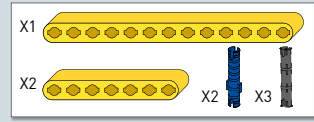

2

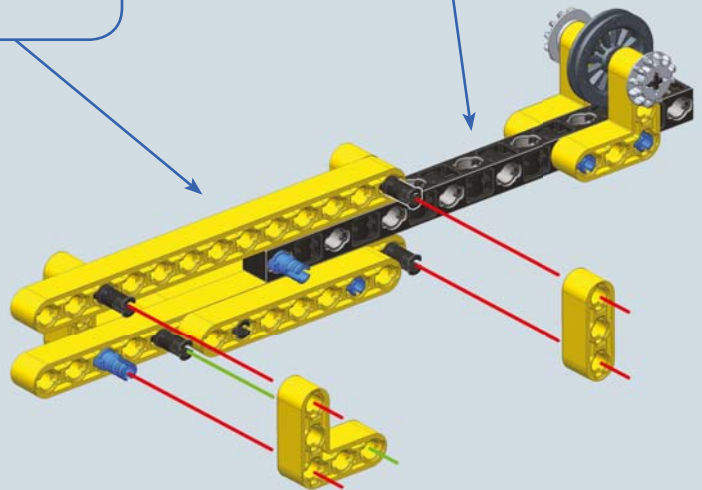
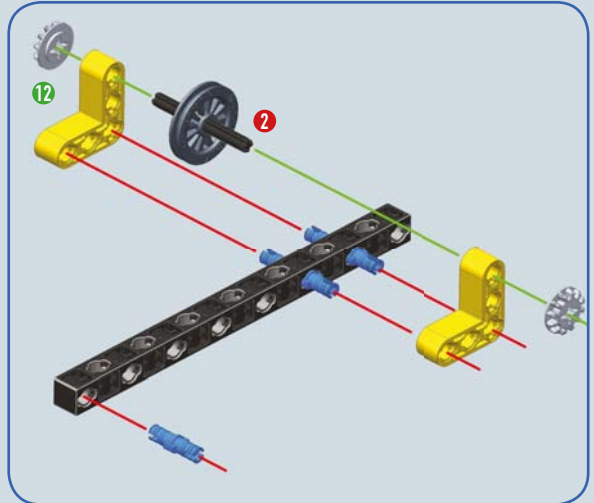
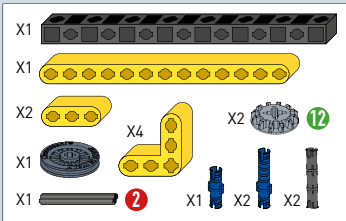

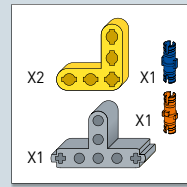
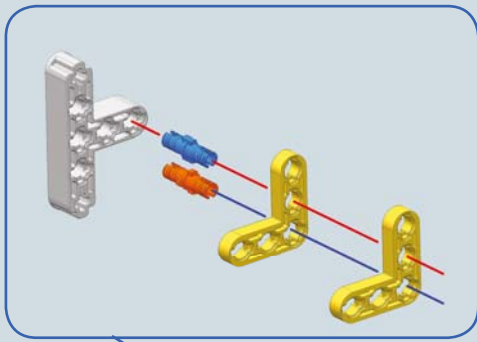

3

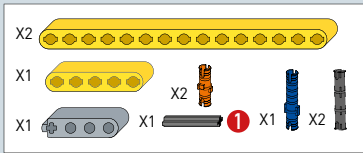
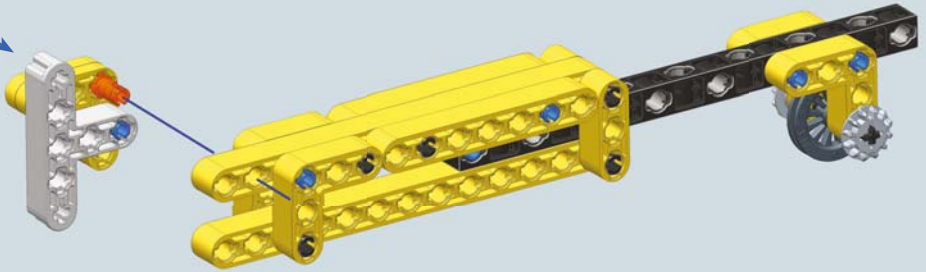

4

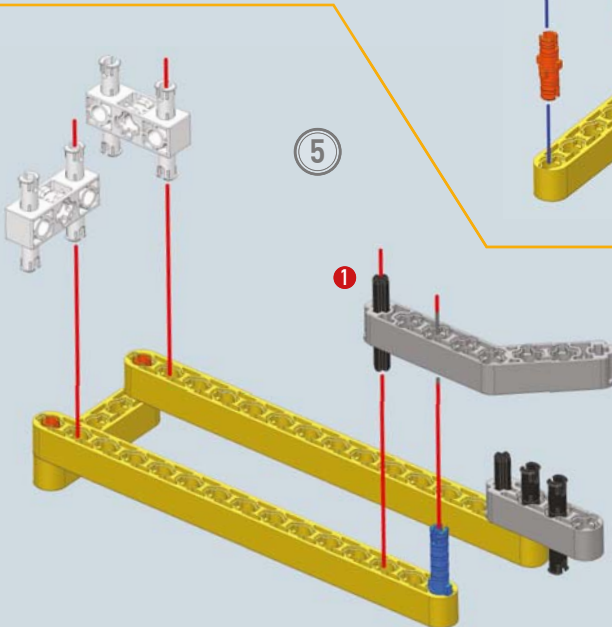
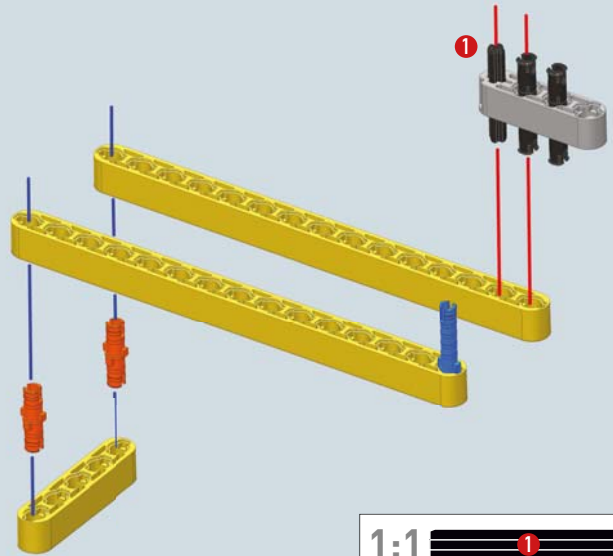

5

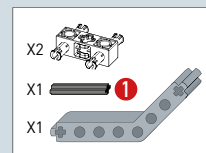

Il braccio della gru è telescopico perché le varie sezioni del braccio scivolano l'una all'interno dell'altra.

6



7

X2

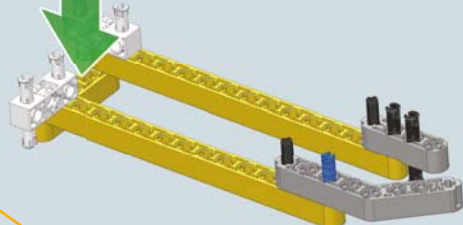
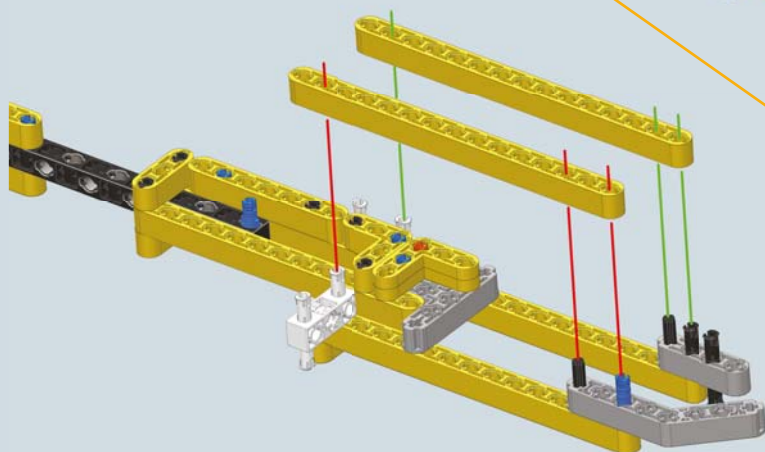

Nei modelli più grandi, il braccio telescopico esteso può arrivare a misurare anche 140m. All'estremità è montato un sistema di carrucole a cui è sospeso il gancio.

8

X3 X2 X1

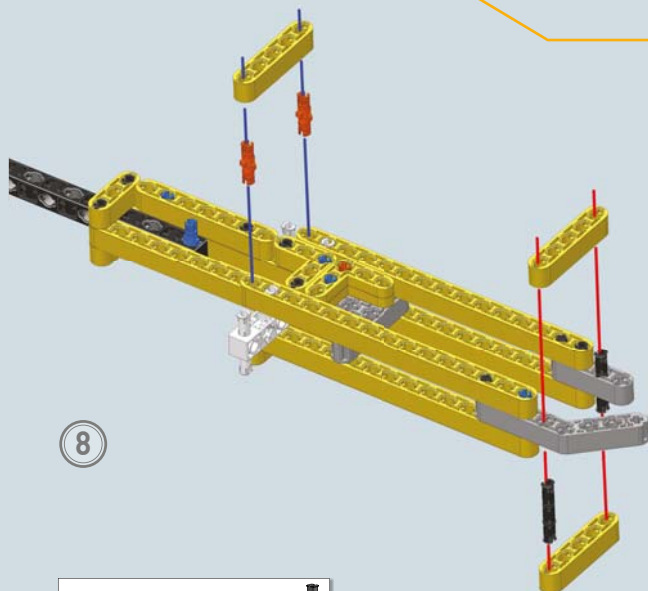



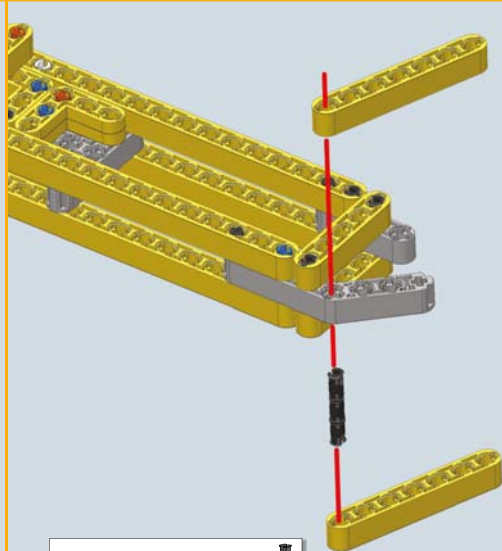



X2 X1

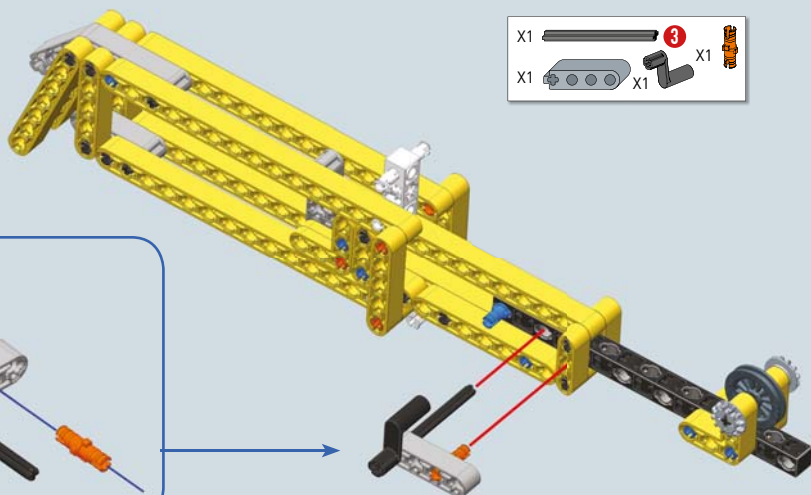
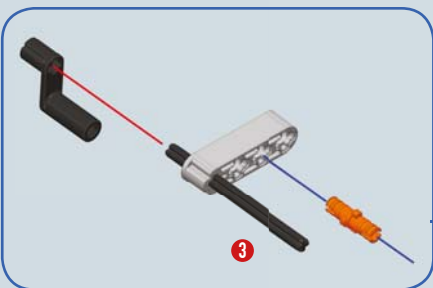

9

10





- X1  3 
- X1  X1  X1 



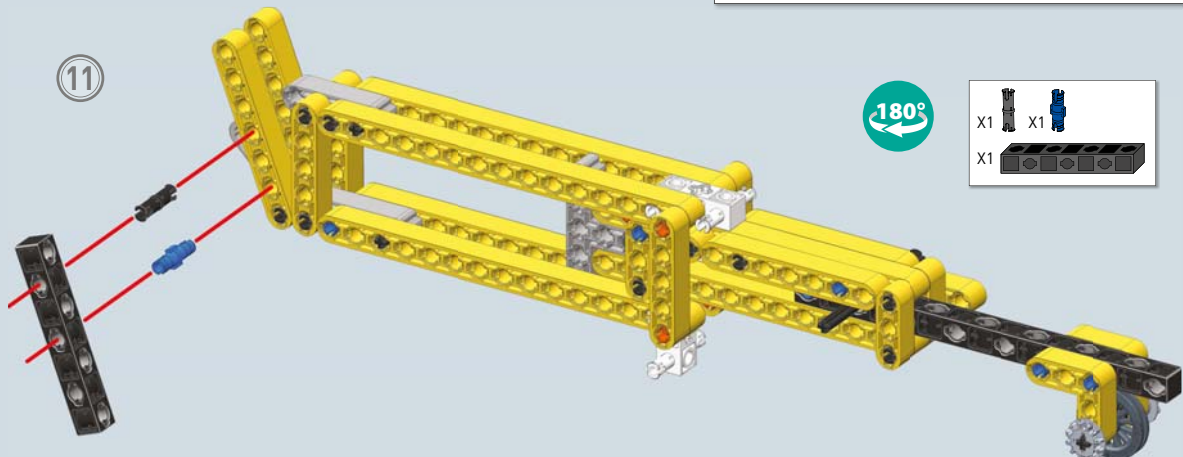



1:1  3

11



- X1  X1 
- X1 

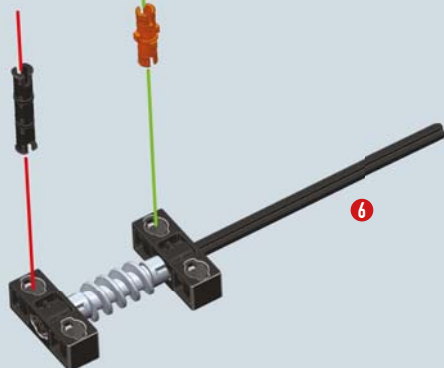

12

- X1  6
- X2  X2 
- X1  X1  X1 

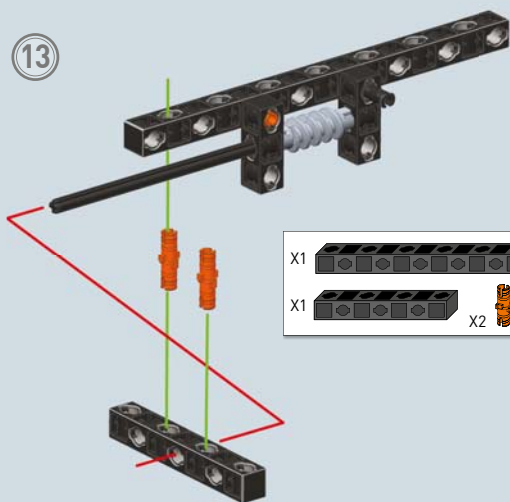

13



- X1 
- X1  X2 

1:1  6

14

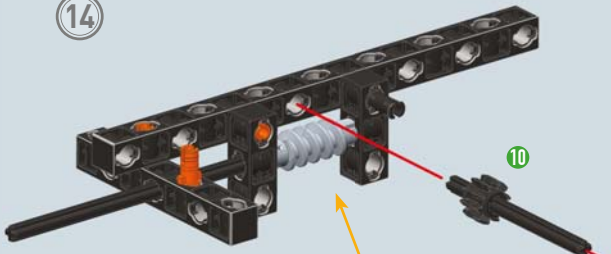

- X1  3
- X1  10

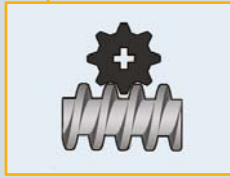

15

- X1  X1 

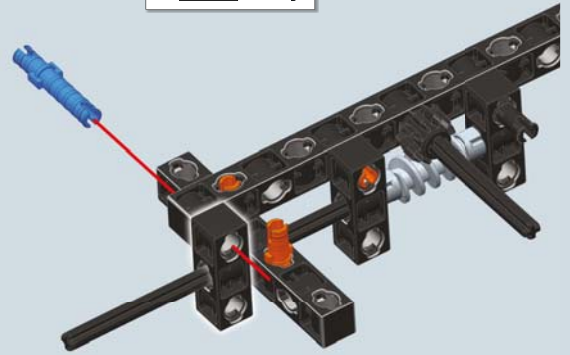

16

- X1 

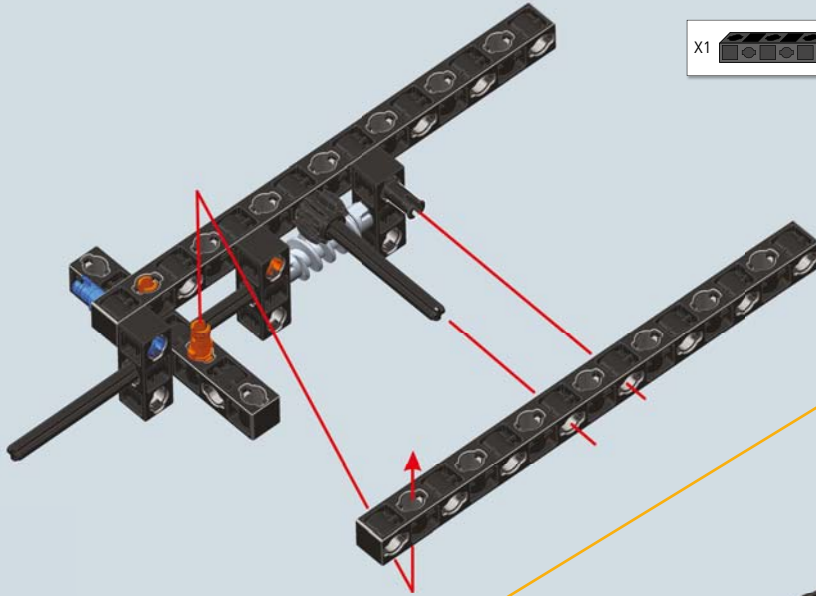

17

- X1  16
- X2 

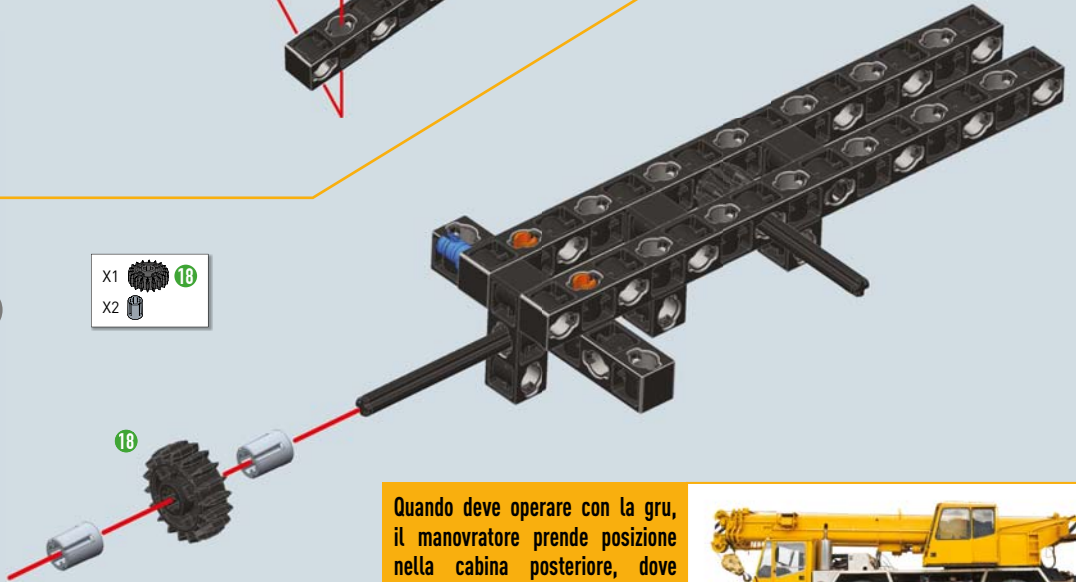

Quando deve operare con la gru, il manoperatore prende posizione nella cabina posteriore, dove si trovano tutti i comandi per il controllo del braccio telescopico.



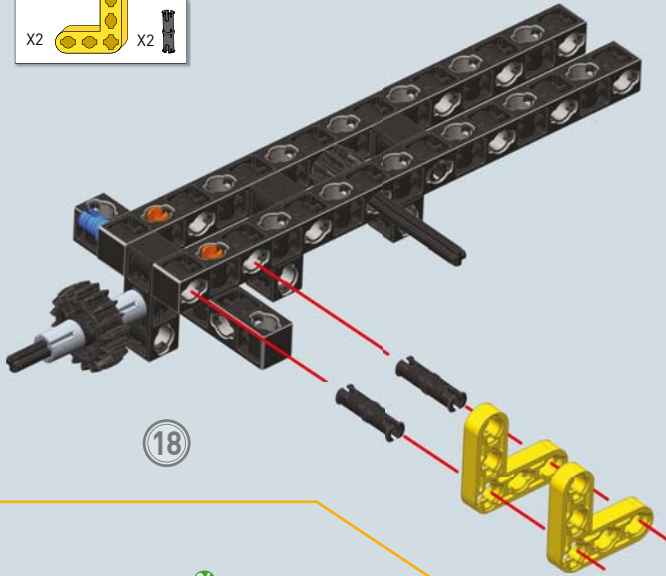
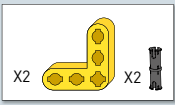

19

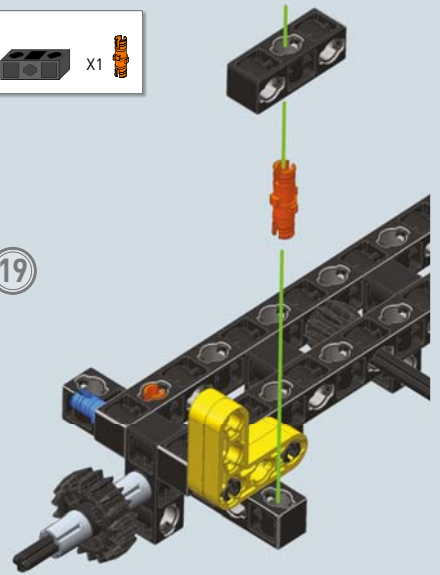

24

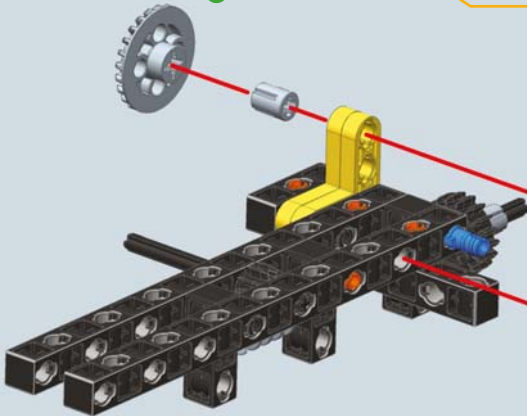

20

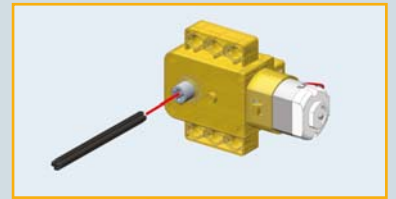

3

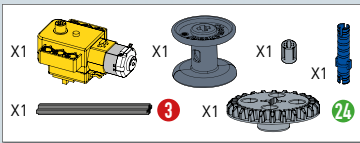
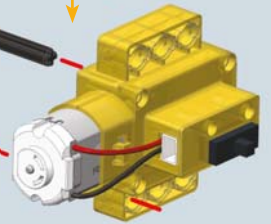

21

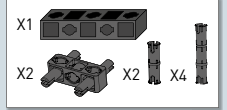
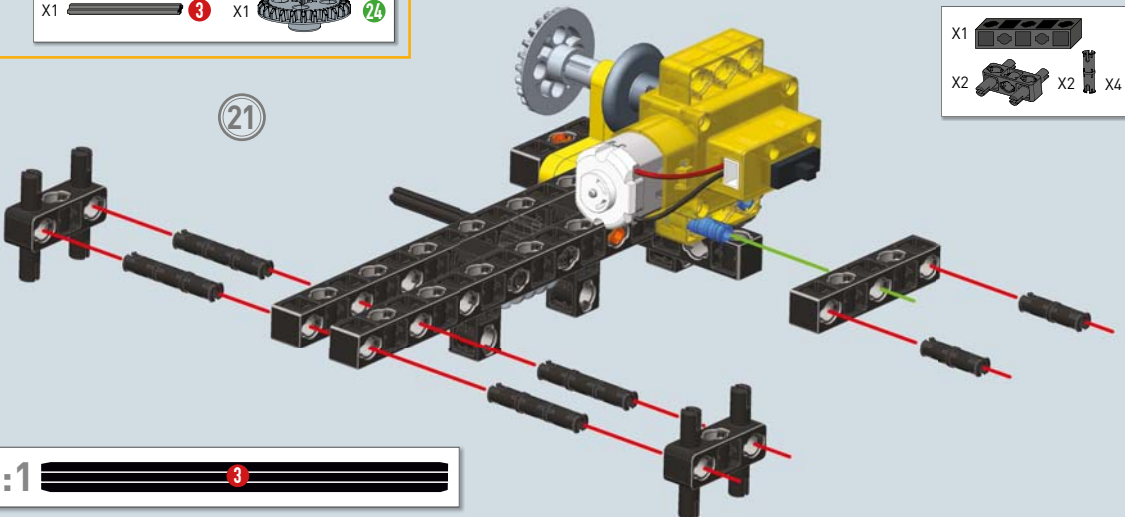

22

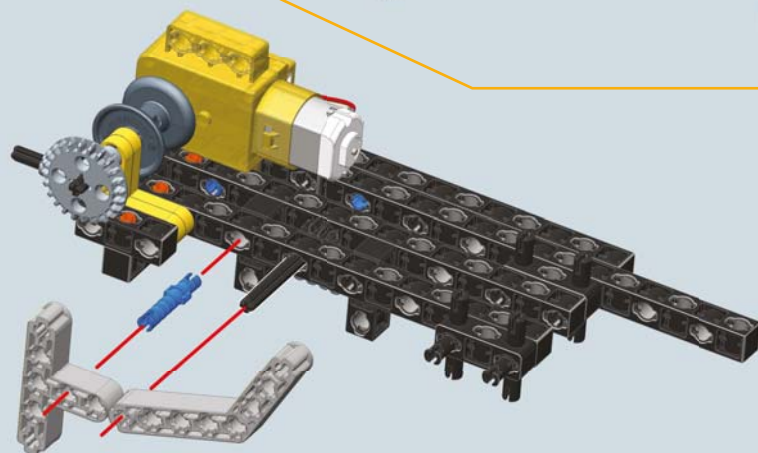
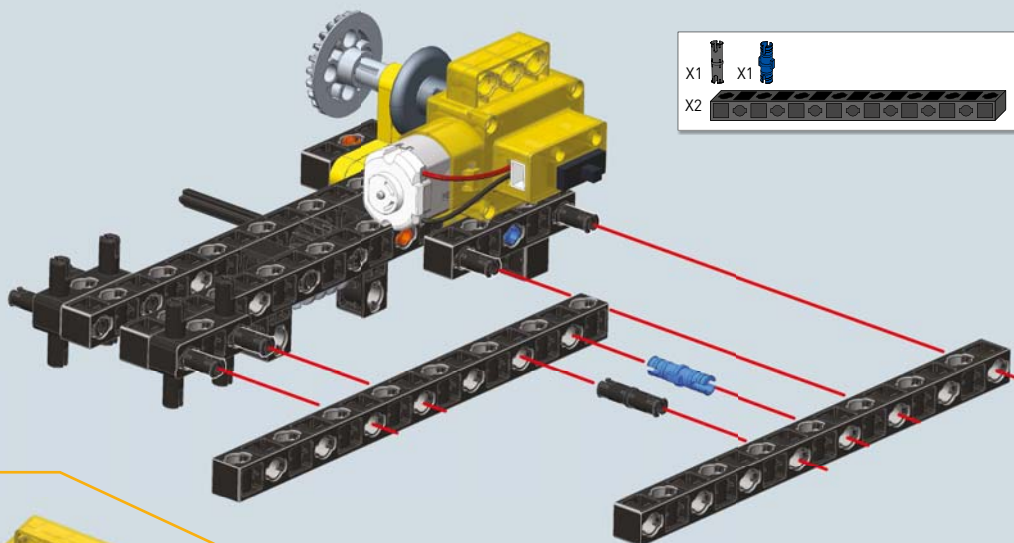

23

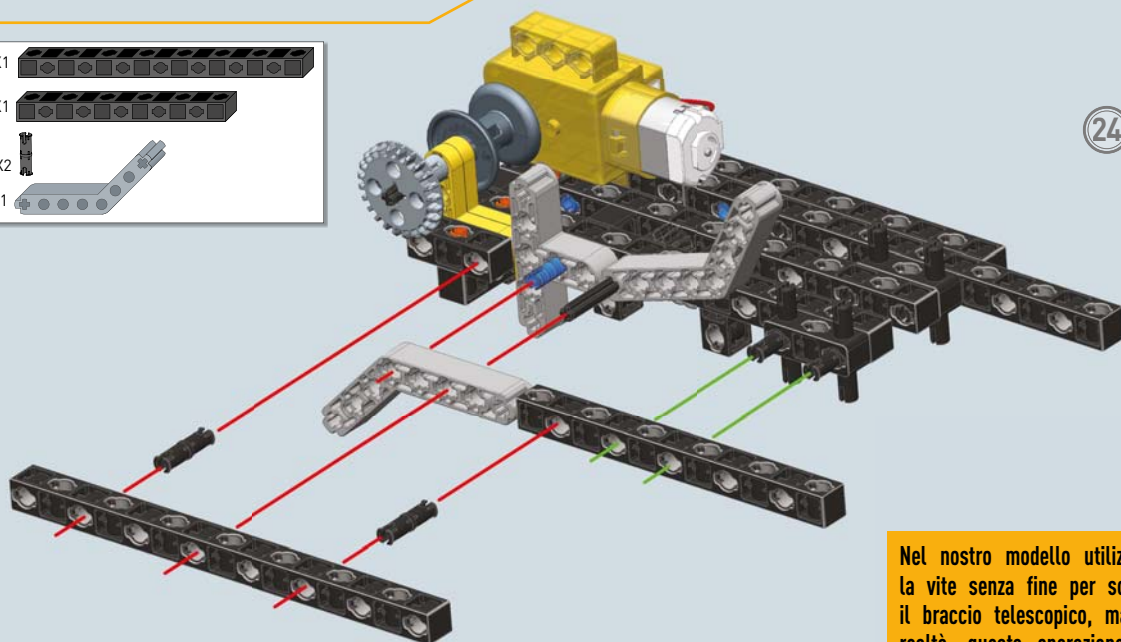
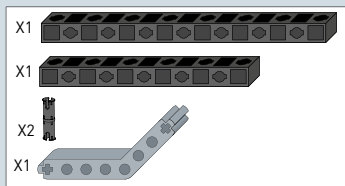
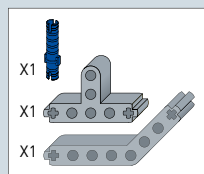

24

Nel nostro modello utilizzeremo la vite senza fine per sollevare il braccio telescopico, ma nella realtà, questa operazione viene effettuata tramite pistoni idraulici.



25

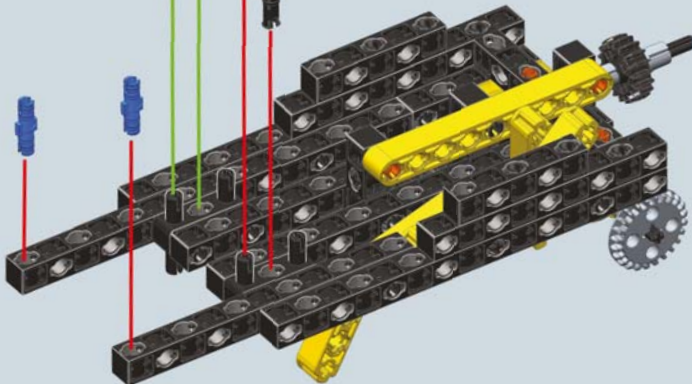
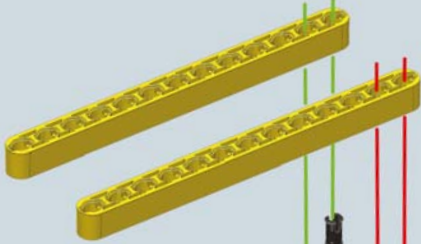
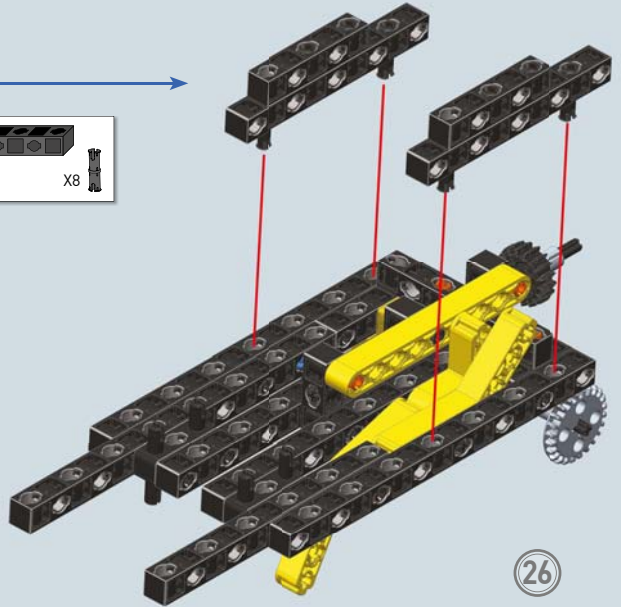
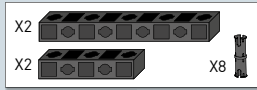
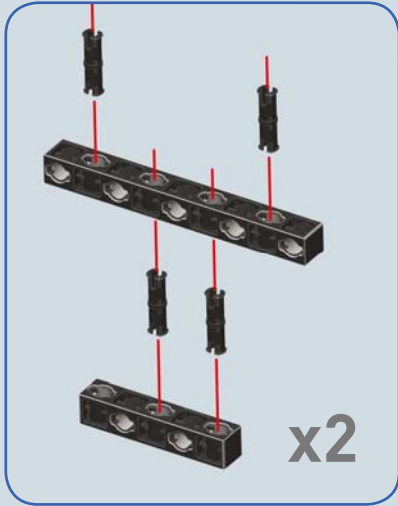
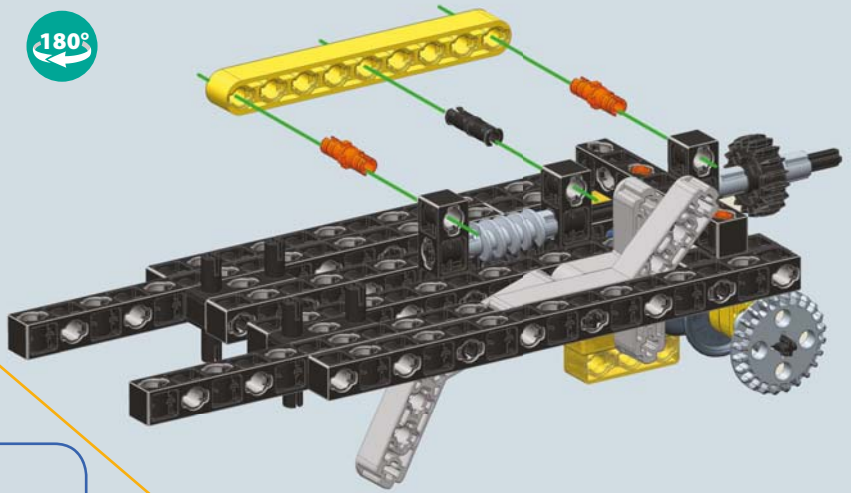

27



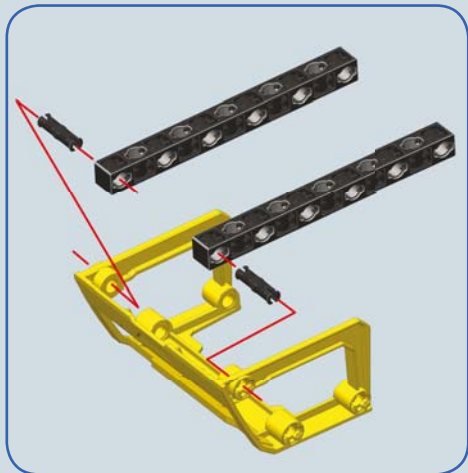

28

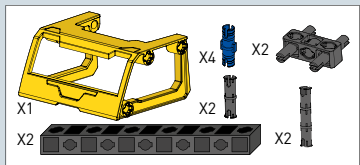
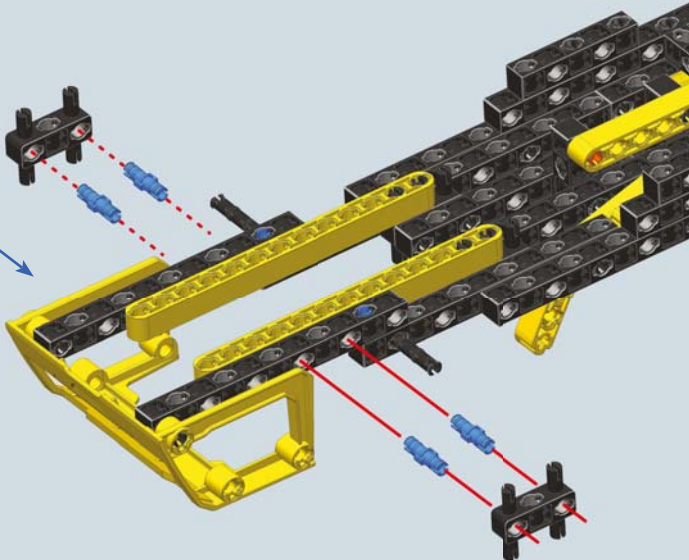

Sistema il vano batterie sopra le due barre gialle, subito dietro la cabina e poi spingi i chiodini neri fino in fondo per fissarlo al telaio. Infine connetti il vano batterie al motore.

29

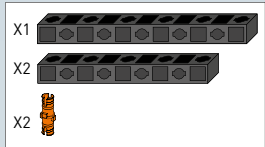
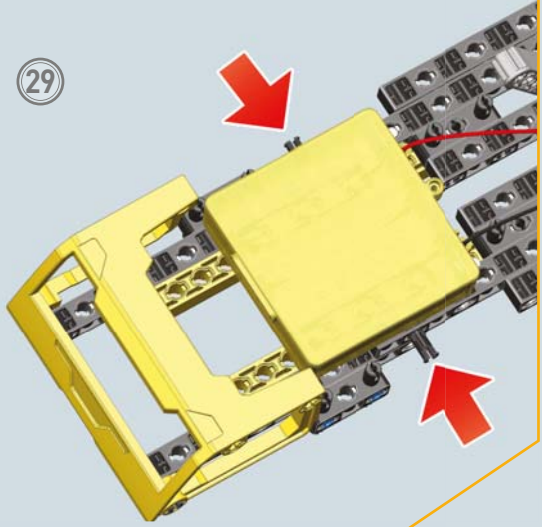

30

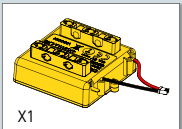
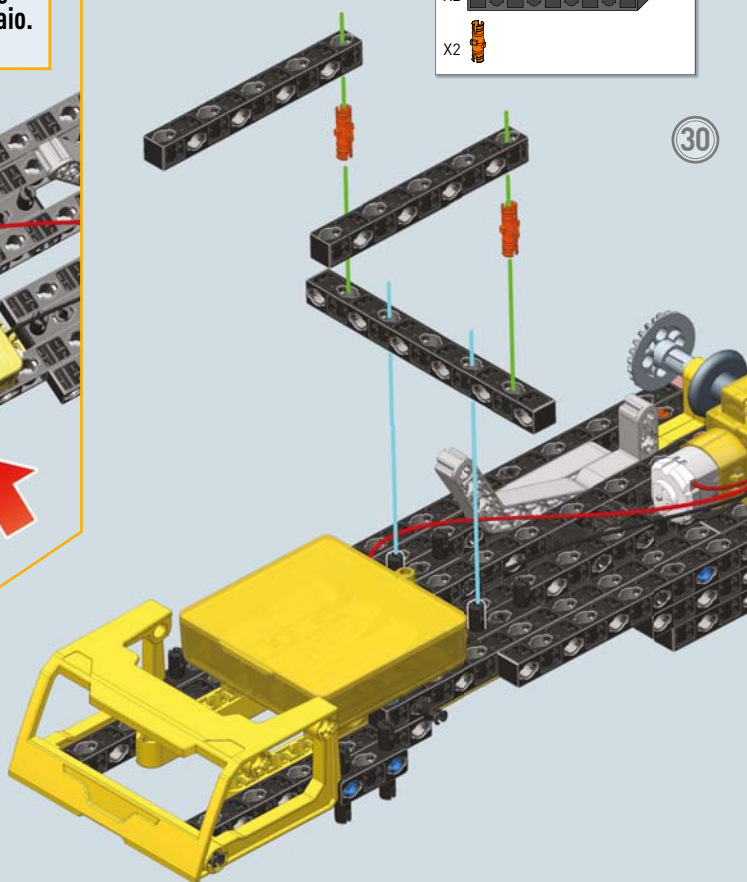

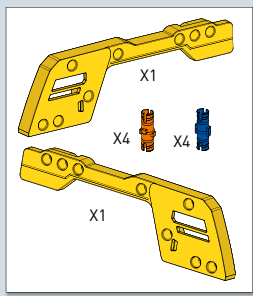

31

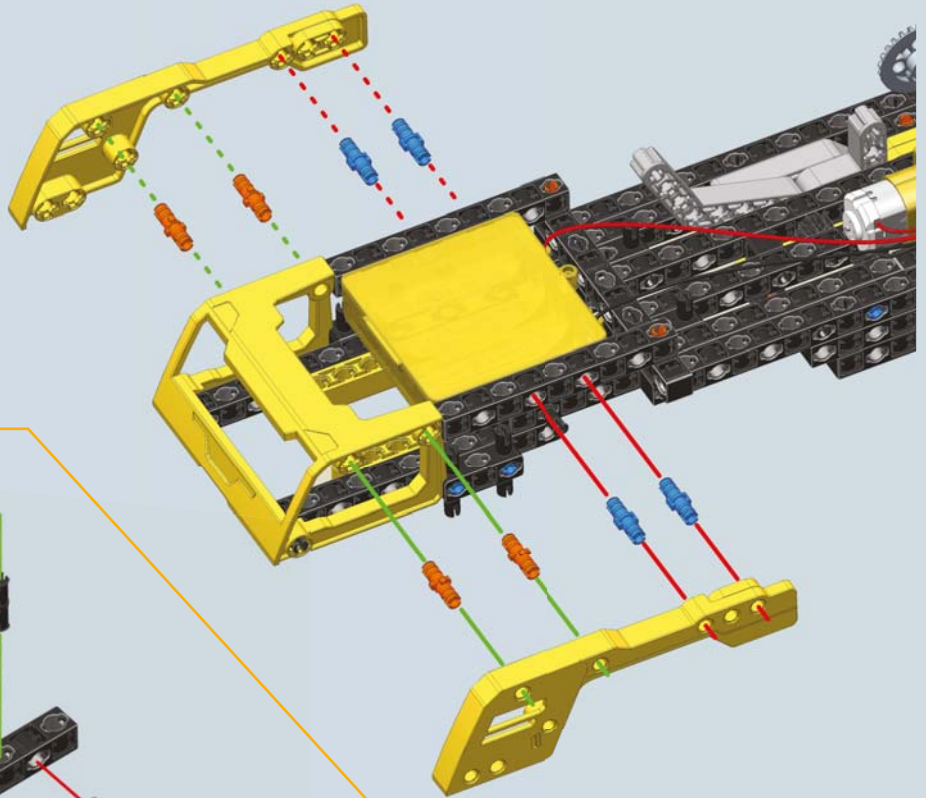

32

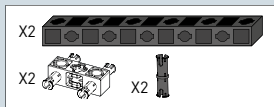
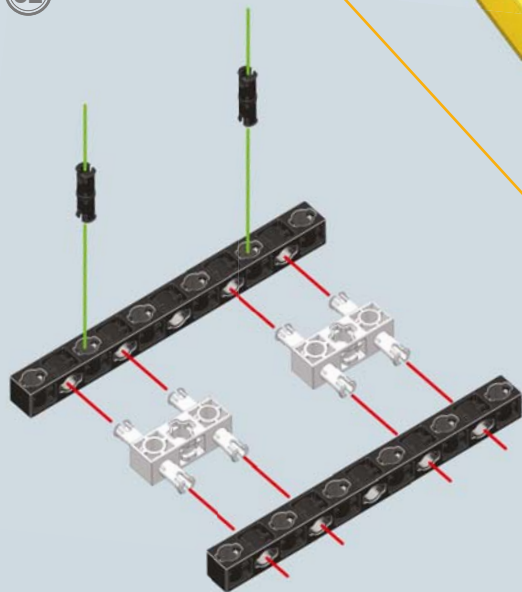

33

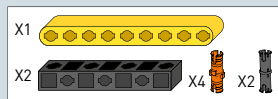
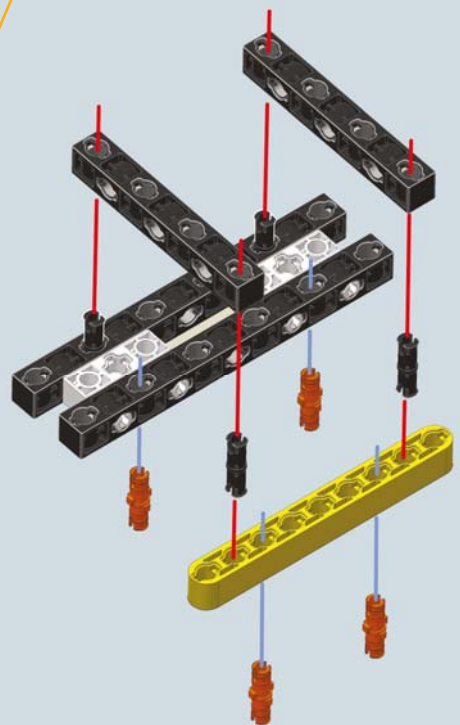

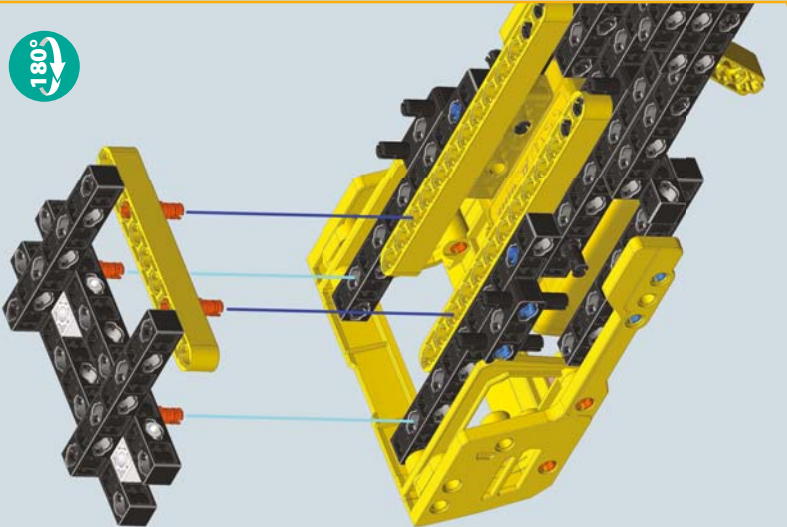
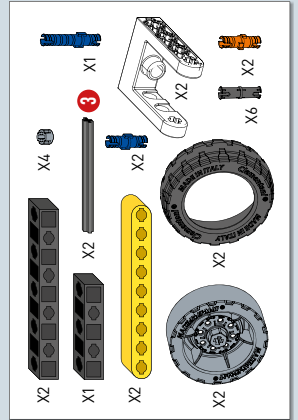
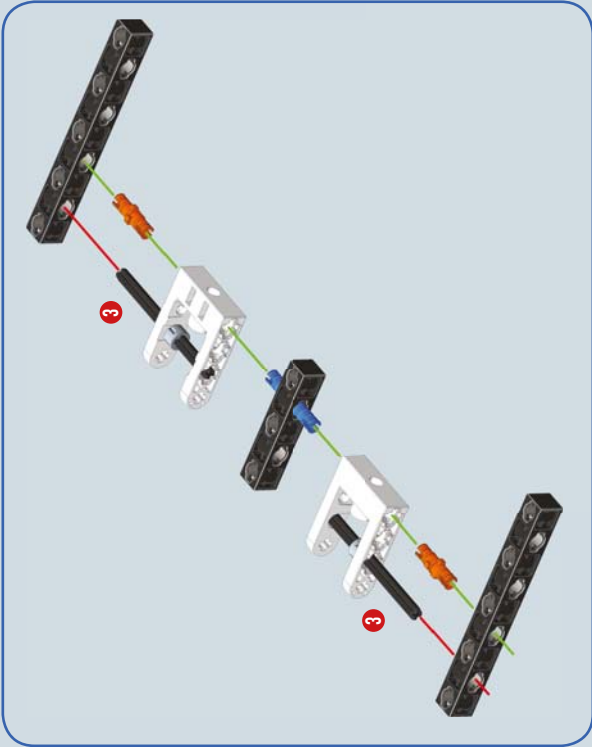
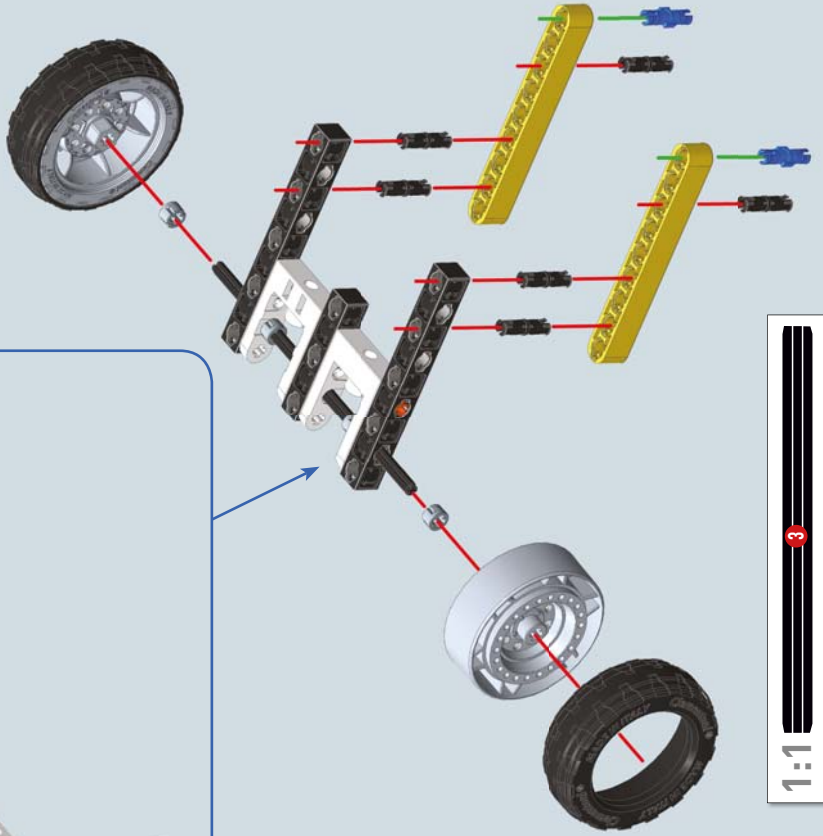



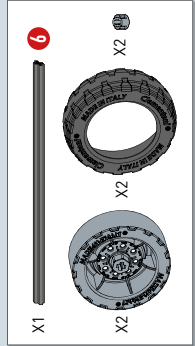
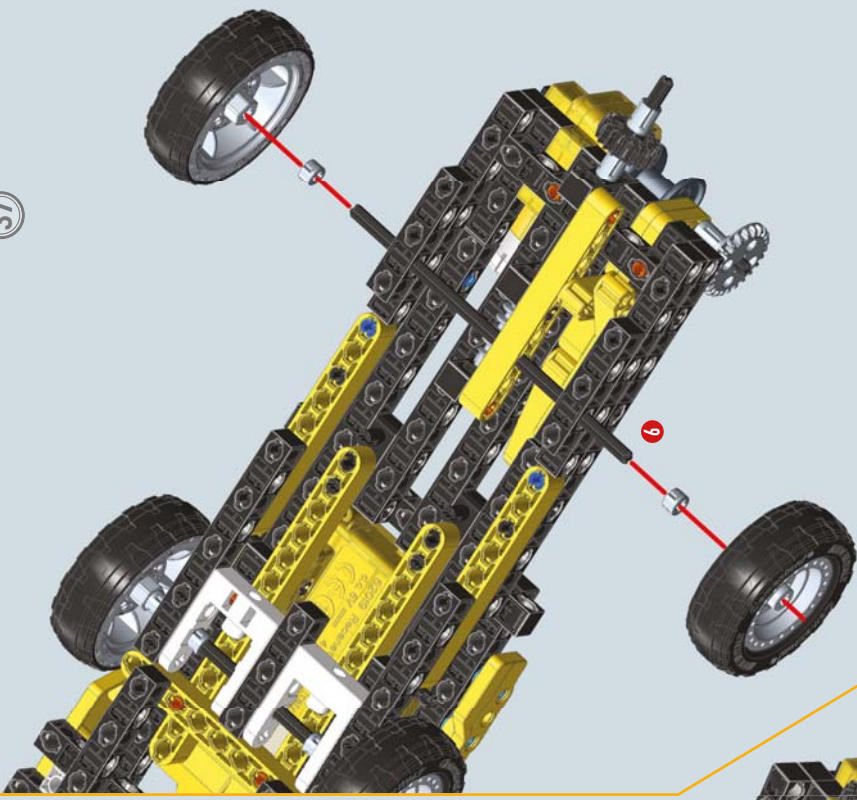

37

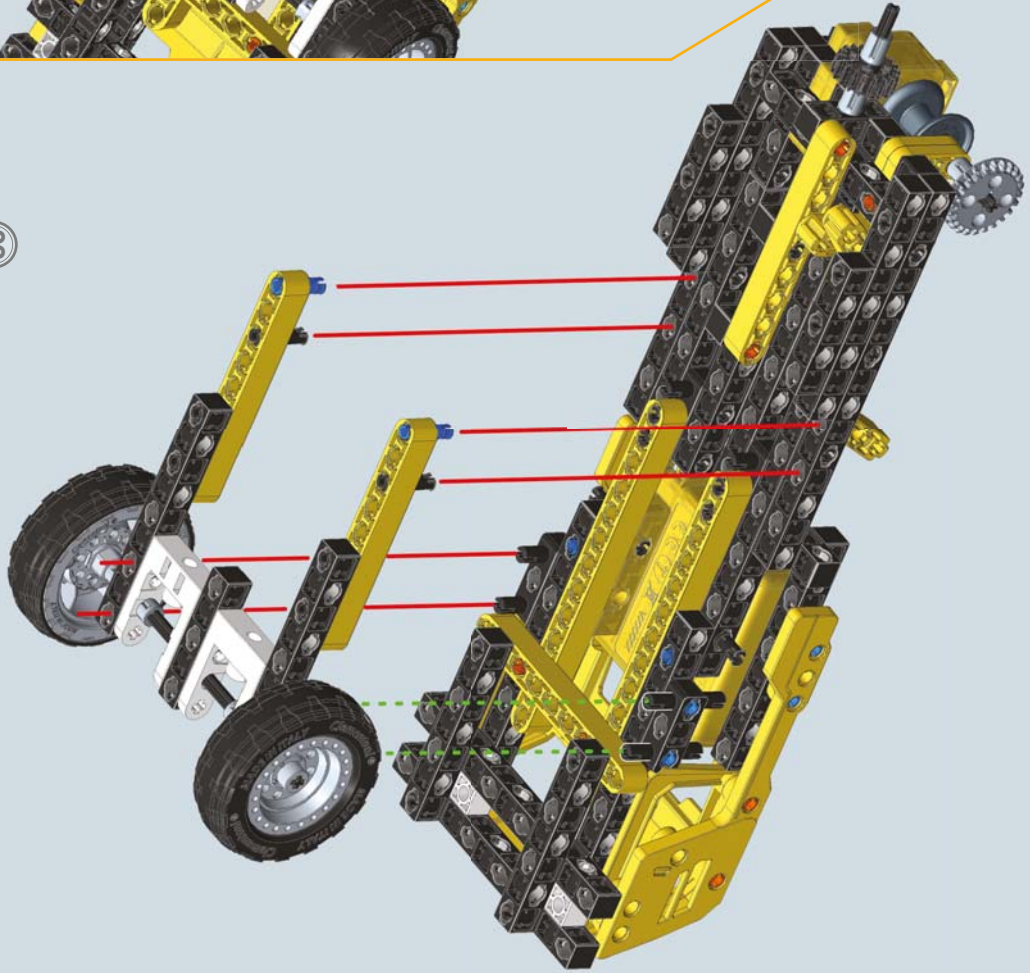

36



- X1  2
- X2  3
- X1  12 X1 

38

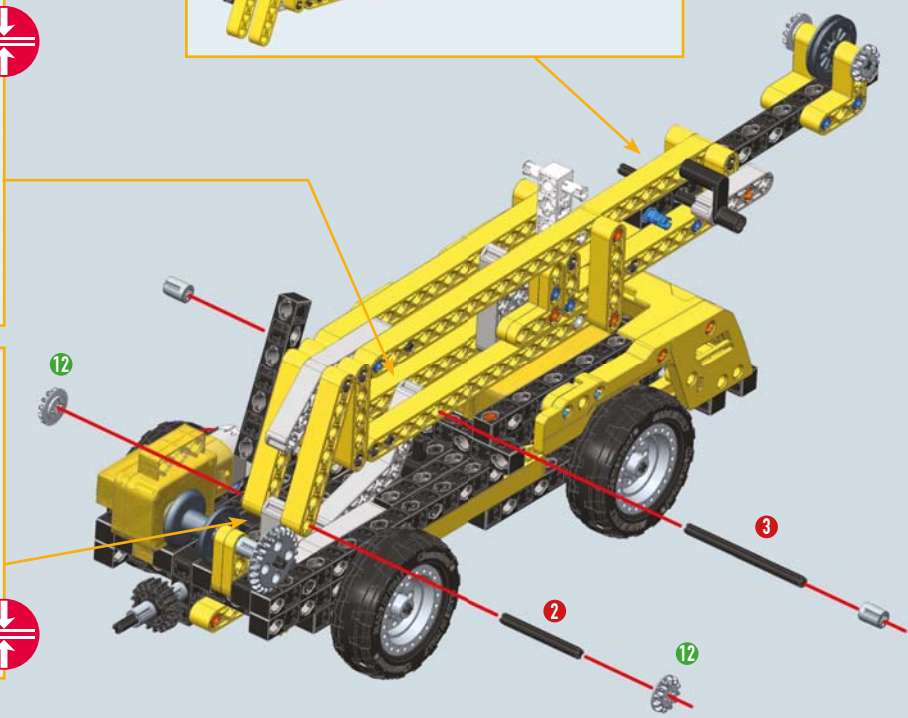
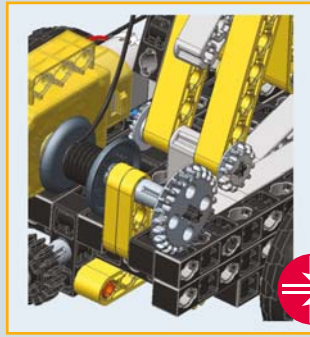
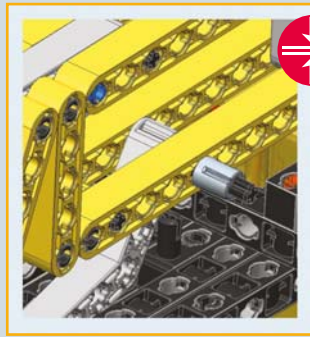
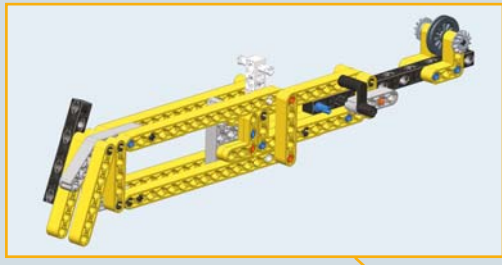

Leγα un capo del filo al rocchetto, poi fallo passare nei giusti fori come nell'immagine. Infine lega il gancio all'altro capo.

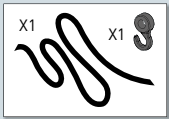

39

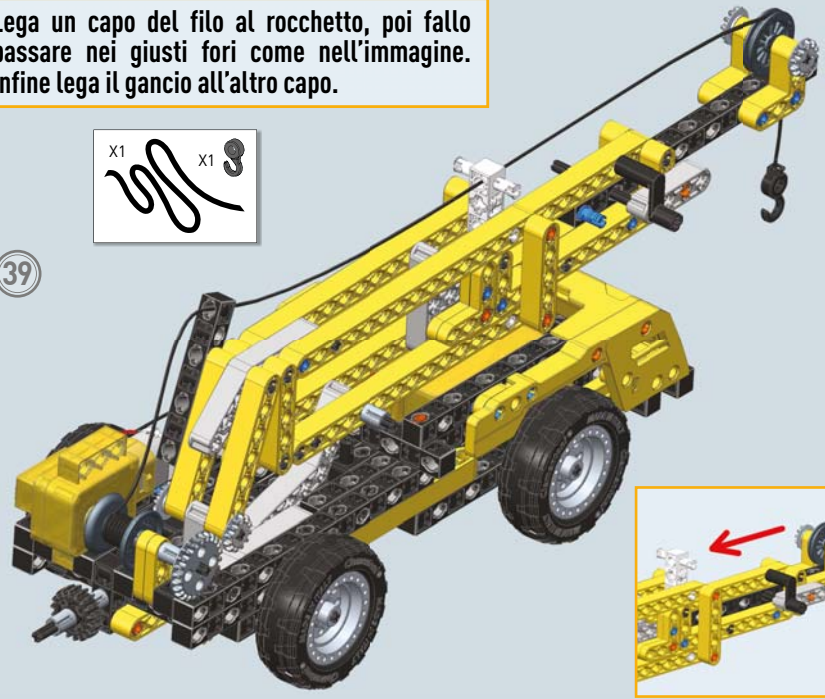
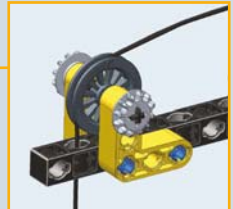

Sfilando l'astina 3 puoi allungare o accorciare manualmente l'ultimo segmento del braccio telescopico. Usala poi per bloccare il braccio nella posizione desiderata.

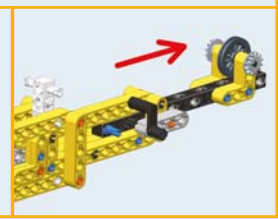
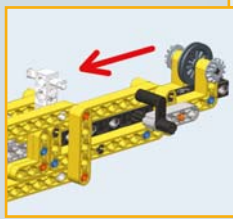

40

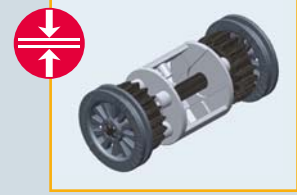
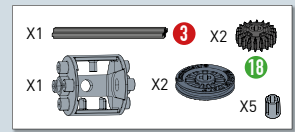
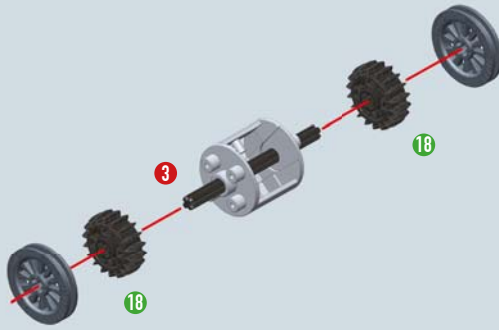

Ruota l'ingranaggio per sollevare o abbassare il braccio telescopico.

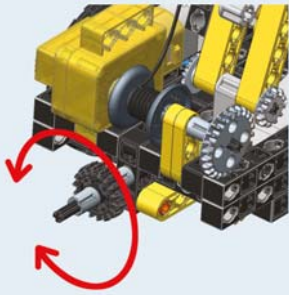

Modello finale

20 Costruisci un ingranaggio a cremagliera

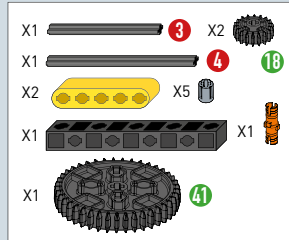
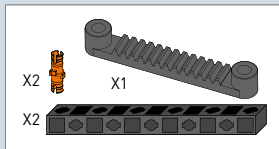

Modello finale

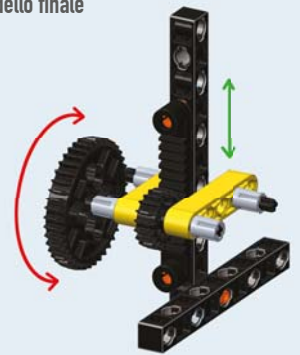

1

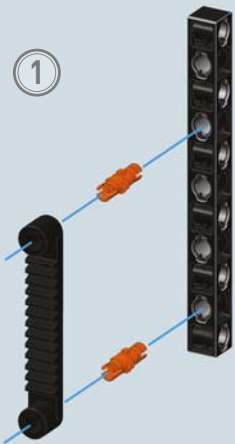

2

