

Laboratorio di MECCANICA

GRU E MEZZI ELEVATORI

Costruzioni da 1 a 35

- 1 - Sovrapposizione di due barre
- 2 - Sovrapposizione di barre con due chiodini
- 3 - Congiunzione di barre
- 4 - Sovrapposizione di tre barre
- 5 - Sovrapposizione perpendicolare di barre
- 6 - Sovrapposizione con una barra ad angolo
- 7 - Costruisci un quadrato con le barre
- 8 - Sovrapposizione di quattro barre
- 9 - Costruisci un parallelepipedo
- 10 - Un ponte con pochi pezzi
- 11 - Le ruote dentate con l'astina
- 12 - Uso delle pulegge
- 13 - Costruisci una leva di 1° genere: tenaglie
- 14 - Costruisci una leva di 2° genere: schiaccianoci
- 15 - Costruisci una leva di 20 genere: carriola
- 16 - Costruisci una leva di 3° genere: pinza
- 17 - Costruisci il fulcro delle leve ed il peso
- 18 - Assembla e sperimenta una leva vantaggiosa
- 19 - Assembla e sperimenta una leva indifferente
- 20 - Assembla e sperimenta una leva svantaggiosa
- 21 - Assembla una bilancia
- 22 - Costruisci un'altalena e sperimenta
- 23 - Assembla il banco di prova per la rotazione inversa
- 24 - Costruisci e sperimenta la rotazione diretta
- 25 - Assembla e sperimenta il moto alternato
- 26 - Costruisci ed osserva una rotazione ad angolo retto
- 27 - Assembla una trasmissione verticale
- 28 - Costruisci una trasmissione verticale-orizzontale
- 29 - Un'antica macchina bellica: l'ariete
- 30 - Assembla un cambio meccanico con gli ingranaggi

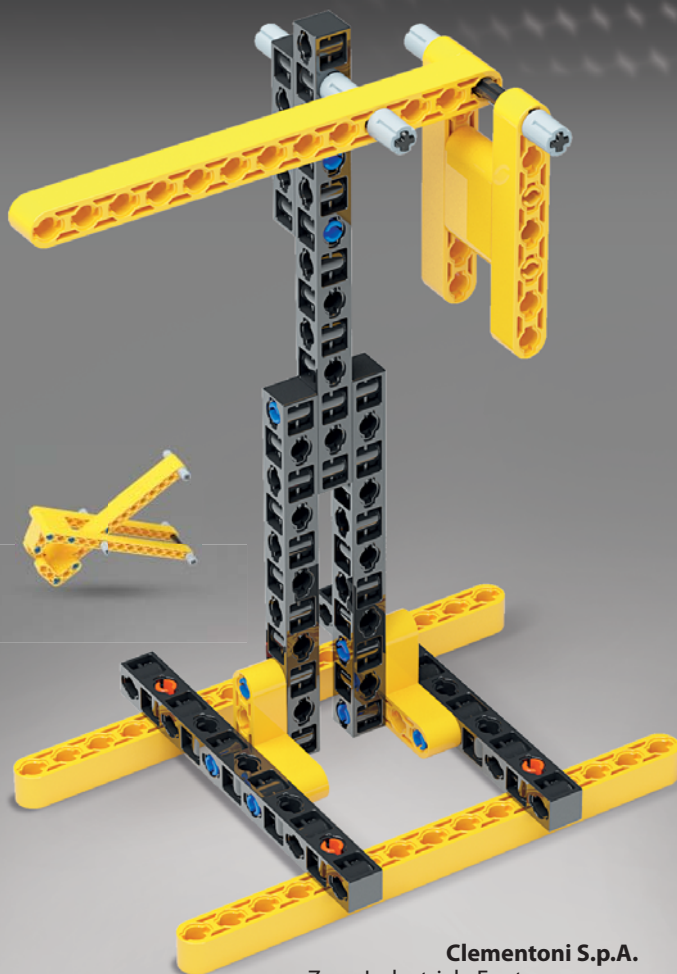

Assistenza clienti

Tel. 02.82.52.52

Email - assistenza@clementoni.it

ATTENZIONE!

Solo per bambini di 8 anni e oltre. Le istruzioni per gli adulti sono incluse e devono essere rispettate.

Manuale da leggere e conservare per future referenze.

Clementoni S.p.A.
Zona Industriale Fontenoce s.n.c.
62019 Recanati (MC) Italy
Tel.: +39 071 75811 - Fax: +39 071 7581234
www.clementoni.com

1 Sovrapposizione di due barre

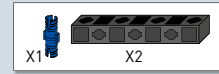

Barre assemblate

2 Sovrapposizione di barre con due chiodini

Con due chiodini l'operazione è ben solida!

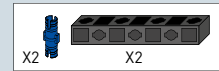
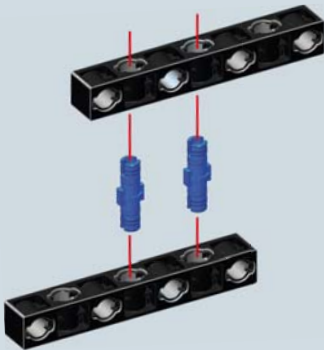

Barre assemblate

3 Congiunzione di barre

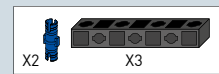
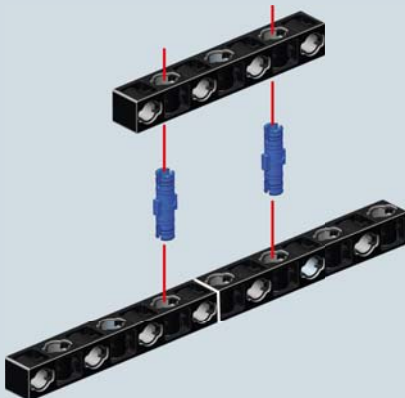

Barre assemblate

4 Sovrapposizione di tre barre

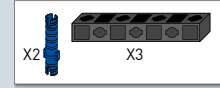

Barre assemblate

5 Sovrapposizione perpendicolare di barre

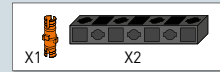

Barre assemblate

6 Sovrapposizione con una barra ad angolo

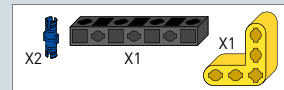
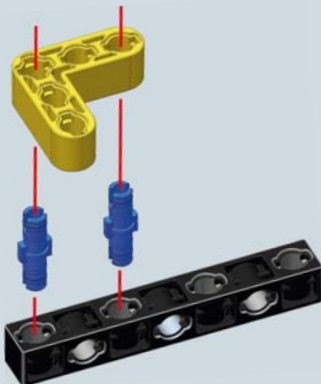

Barre assemblate

7 Costruisci un quadrato con le barre

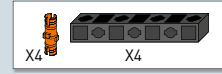
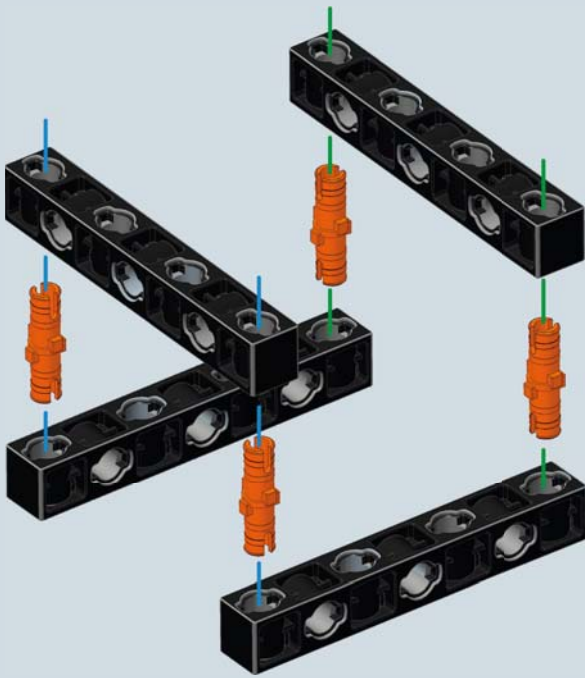

Modello finale

8 Sovrapposizione di quattro barre

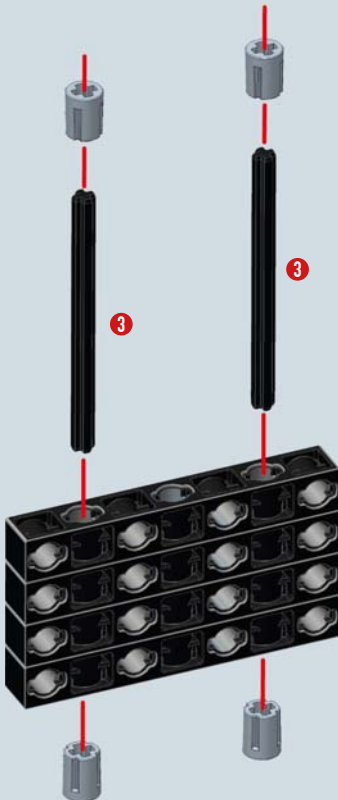

Modello finale





1

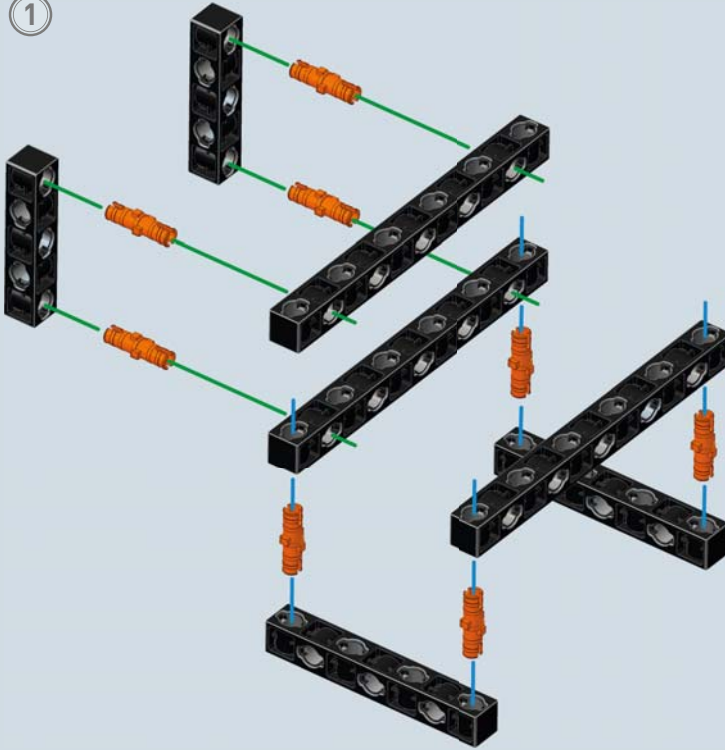

- X3
- X8
- X2
- X2



Modello intermedio assemblato

2

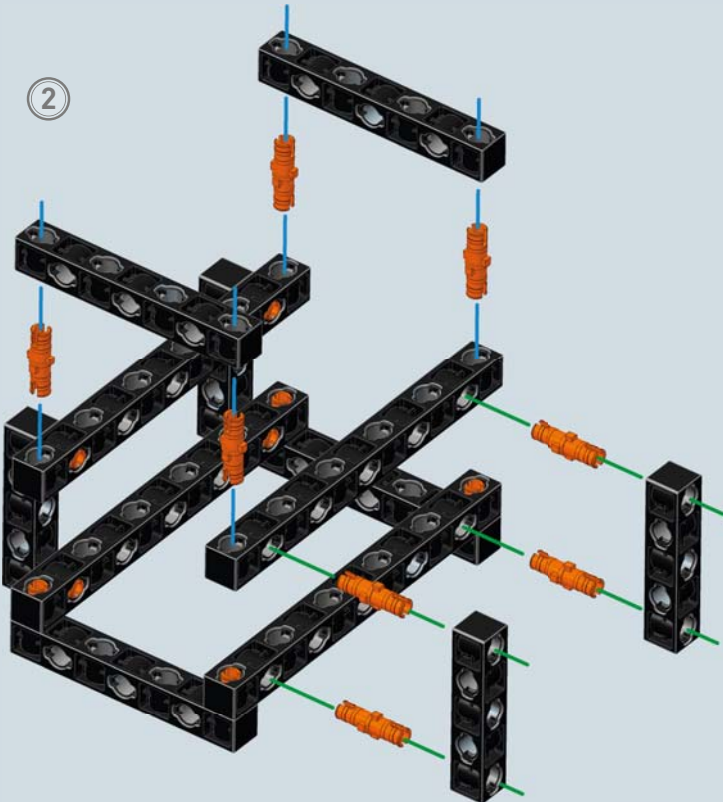

- X1
- X8
- X2
- X2



Modello finale

10 Un ponte con pochi pezzi

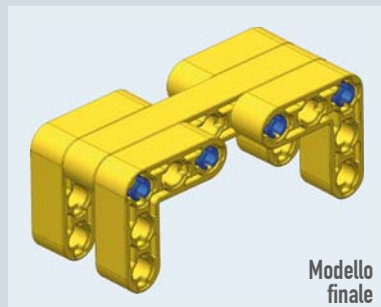
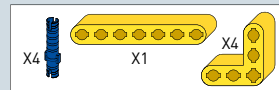
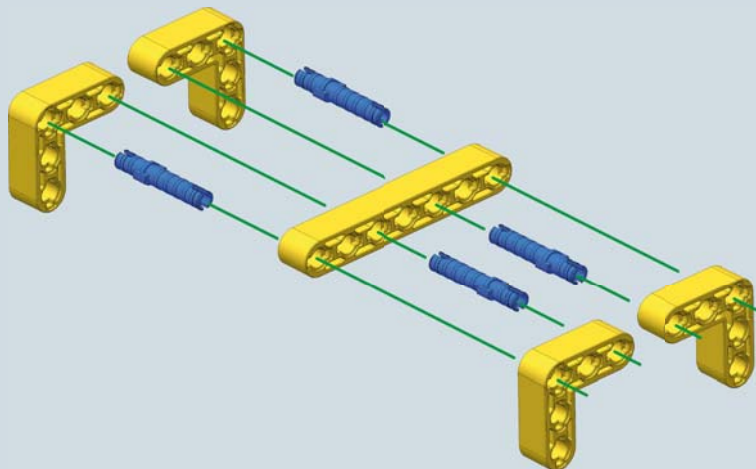

11 Le ruote dentate con l'astina

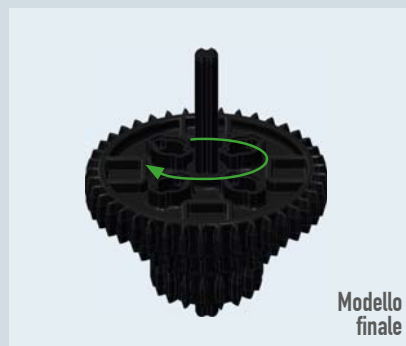
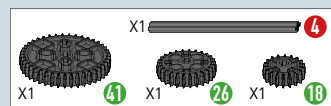
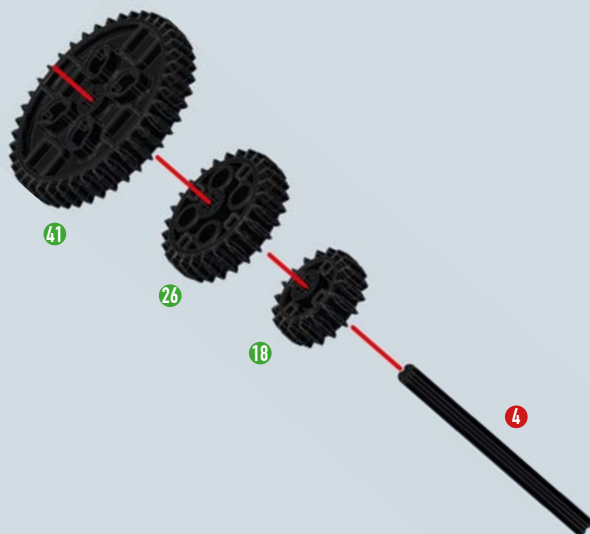

Puoi provarla come trottole!

12 Uso delle pulegge

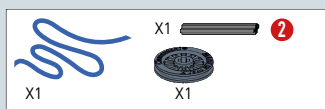

Fin dall'antichità alcuni di questi congegni hanno permesso all'uomo di aumentare la propria forza e di compiere particolari lavori fino a realizzare opere grandiose che ancora oggi possiamo ammirare.



Carriola



Tenaglie

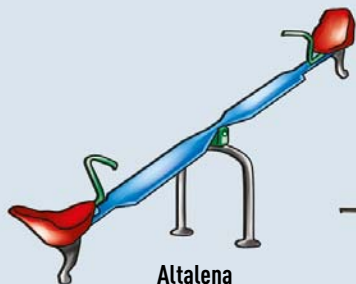

Altalena



Schiaccianoci



Bilancia



Carrucola

Una macchina semplice è uno strumento che permette di equilibrare e superare la **RESISTENZA** (peso, forza resistente = **R**) con la **POTENZA** (forza dell'uomo=**P**).

LEVE

La leva è una macchina semplice costituita da un'asta rigida che può ruotare attorno ad un punto fisso detto fulcro.



- Anche coppie di leve rispettano questo principio.
- Le leve sono classificate in base alla posizione relativa di **POTENZA**, **RESISTENZA** e **FULCRO**.

1

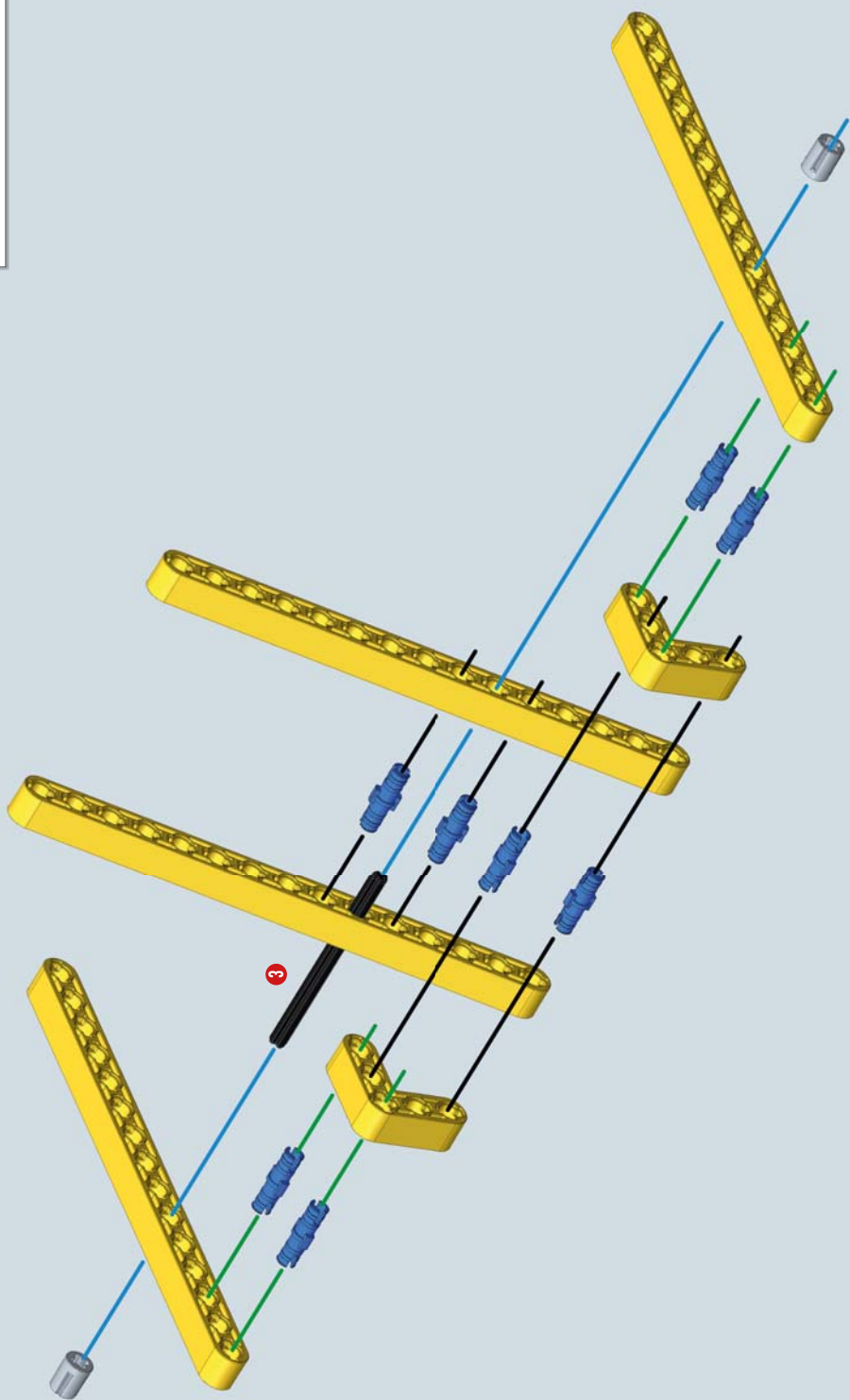
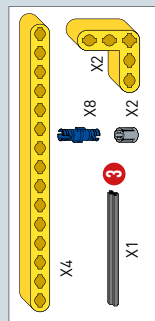

1:1

2

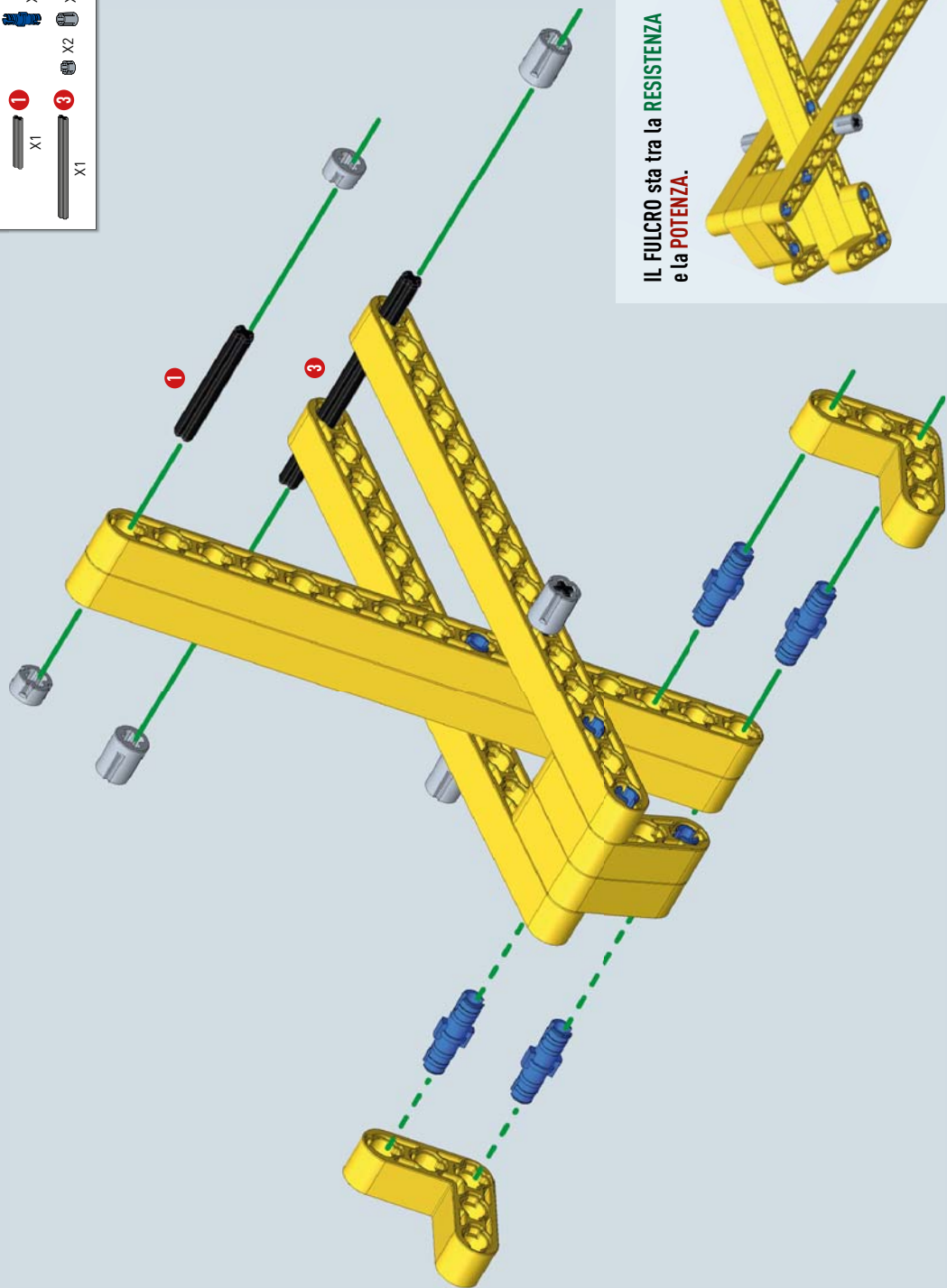

IL FULCRO sta tra la RESISTENZA
e la POTENZA.



Modello finale

1:1

1

1:1

15 Costruisci una leva di 2° genere: carriola

- X2
- X2
- X1
- X2
- X2
- X2
- X1
- X4
- X4

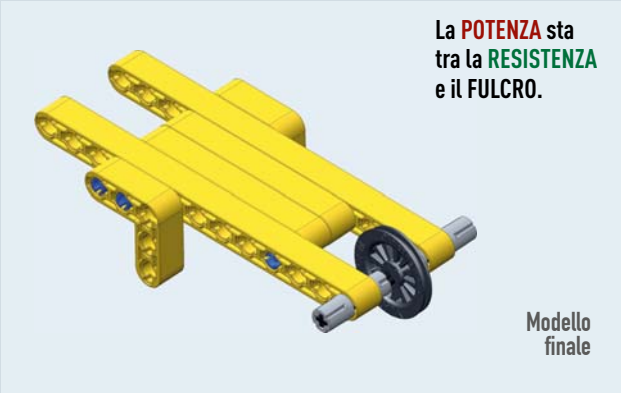
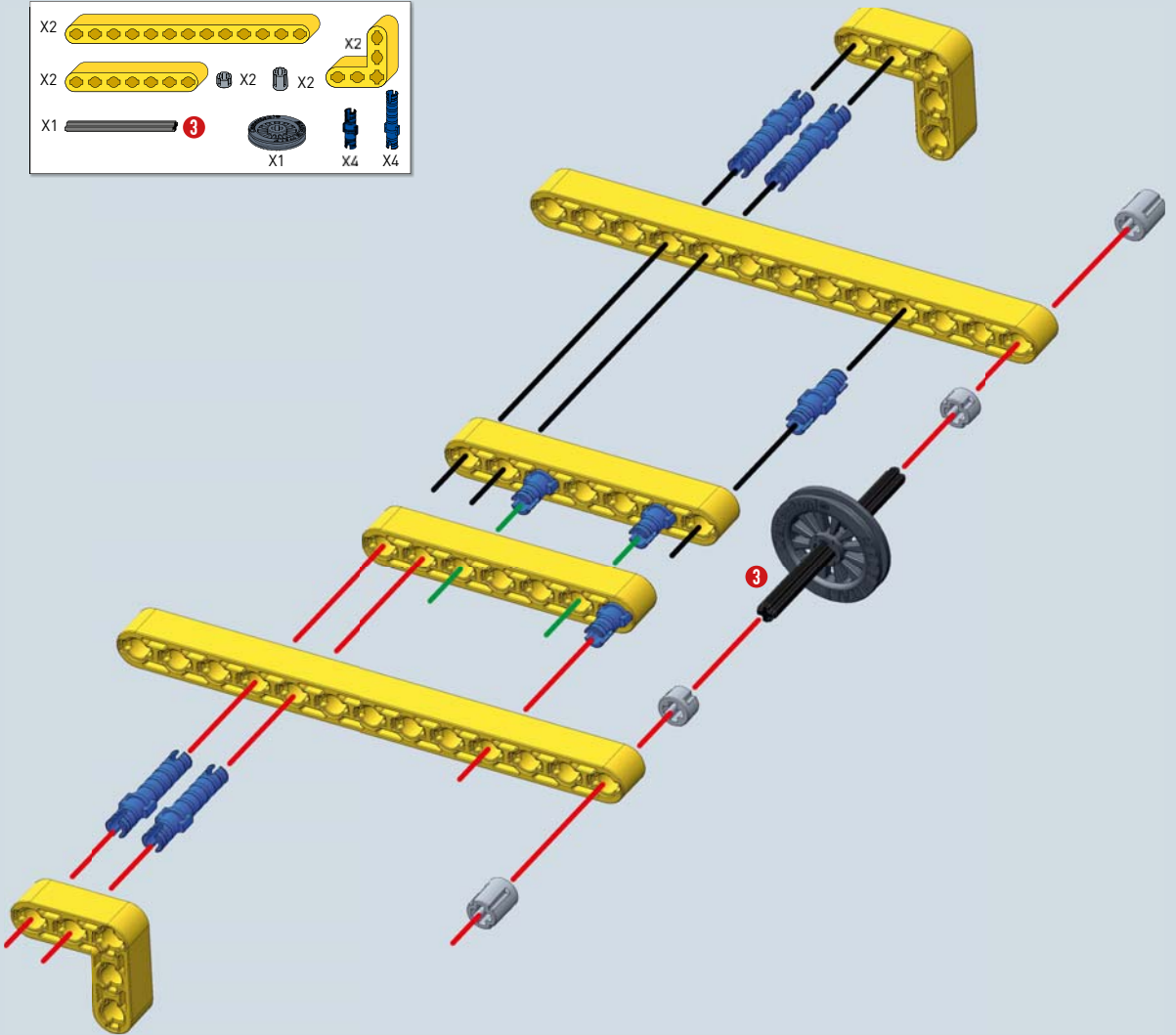

La **POTENZA** sta tra la **RESISTENZA** e il **FULCRO**.

Modello finale



1

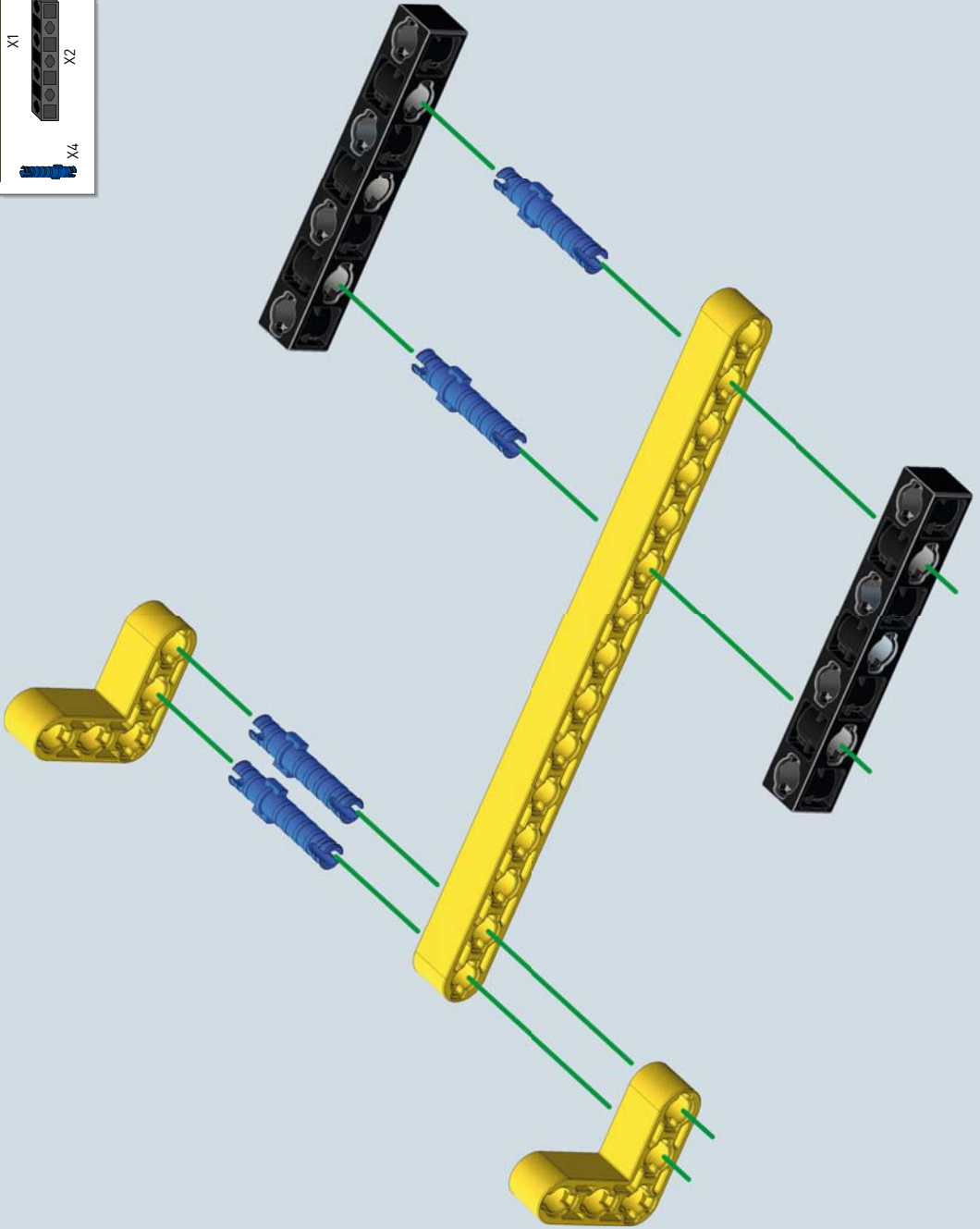
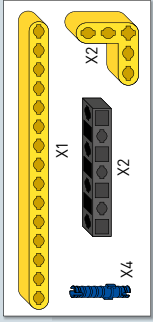

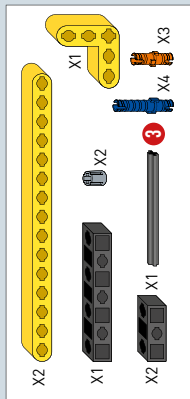

2

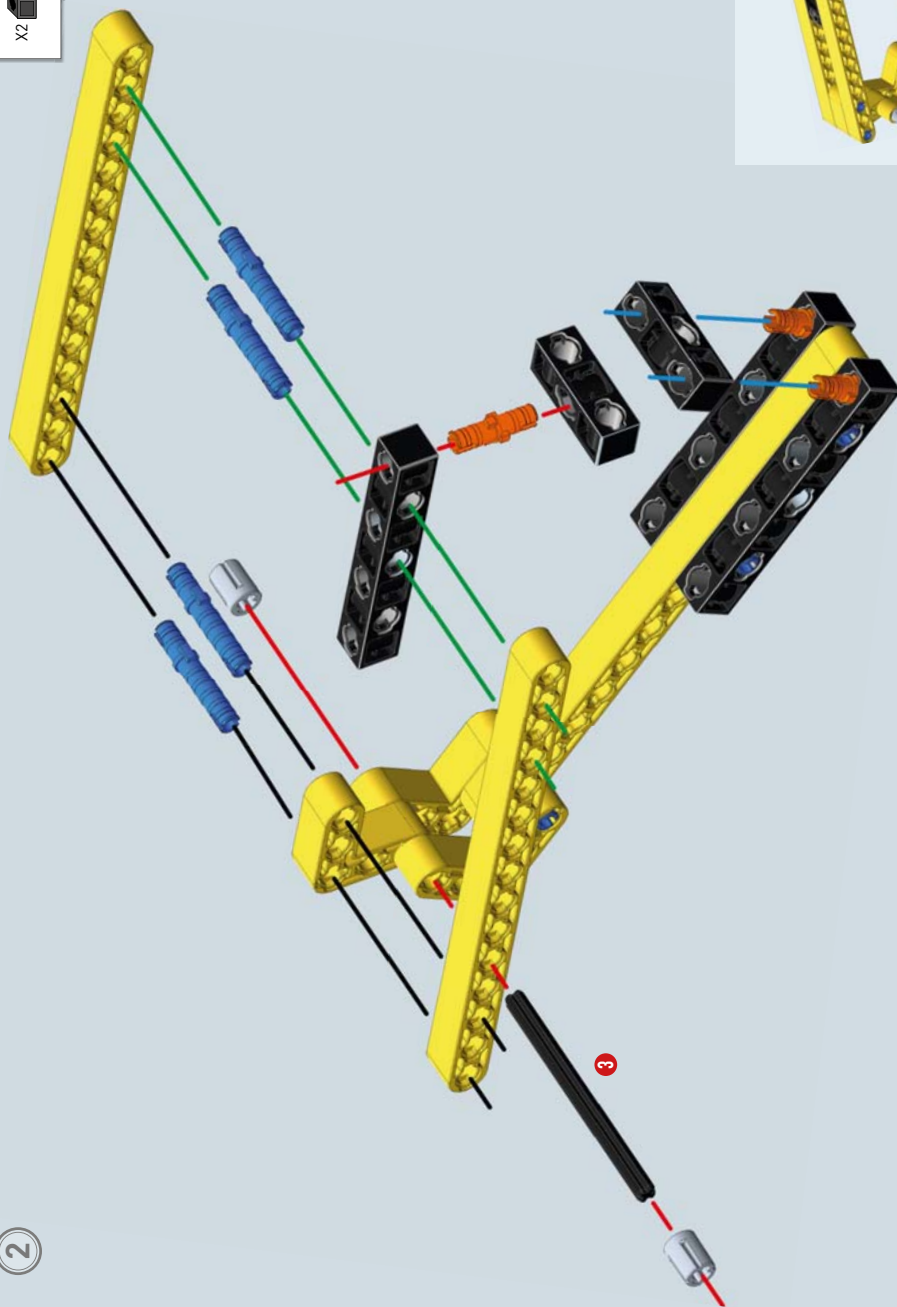

La **POTENZA** sta
tra la **RESISTENZA**
e il **FULCRO**.

Modello finale



La leva è una macchina semplice costruita dall'uomo con l'obiettivo di eseguire un lavoro riducendo la forza impiegata. Sull'asta sono applicate due forze: una la **POTENZA** e l'altra la **RESISTENZA**. Quindi, usando una leva, si ha un **GUADAGNO MECCANICO** che può essere calcolato considerando anche la lunghezza dei bracci della **POTENZA** e della **RESISTENZA**. Nella leva, le lunghezze dei bracci corrispondono alle distanze dal fulcro.

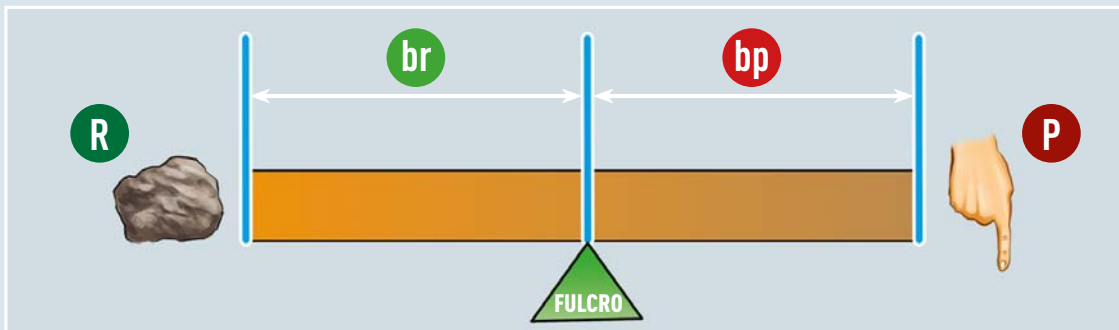

- Legenda: **bp** = braccio della **POTENZA**
br = braccio della **RESISTENZA**
P = forza della **POTENZA**
R = forza della **RESISTENZA**

CONDIZIONI DI EQUILIBRIO $br \times R = bp \times P$

GUADAGNO MECCANICO $G = R / P$

ASSEMBLA E SPERIMENTA LE LEVE

17 Costruisci il fulcro delle leve ed il peso

1

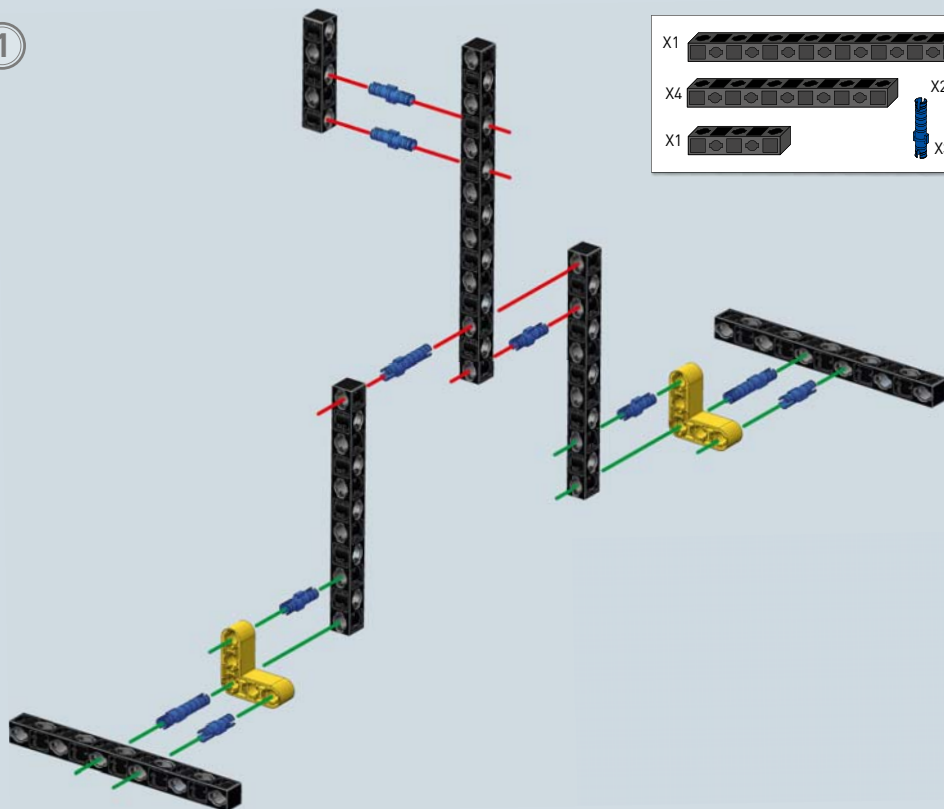

2

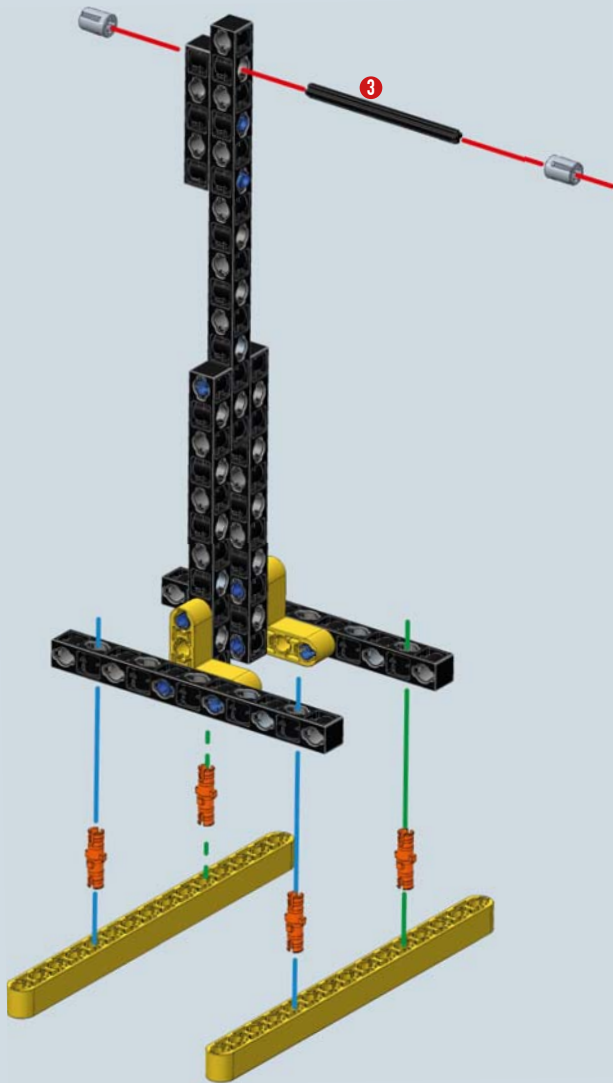

X2	
X1	
X2	
X4	

MONTAGGIO DEL PESO

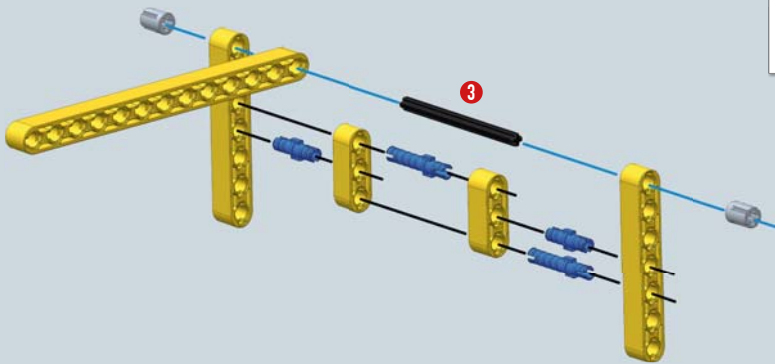

X1			X2
X2			X2
X1			X2
			X2



Peso assemblato

Nelle attività n° 16-17-18 sposta il fulcro e verifica con la pressione della mano, sul braccio della POTENZA, le differenze esistenti tra le leve.

Trova l'equilibrio in questo tipo di strumento: poni il peso (RESISTENZA) da una parte della leva e premi con la mano (POTENZA) dall'altra parte, fai attenzione alla pressione che eserciti.

Osserva la posizione del fulcro!

- Il braccio della **POTENZA** è più lungo.
- La **POTENZA** è minore della **RESISTENZA**.

SPERIMENTA!

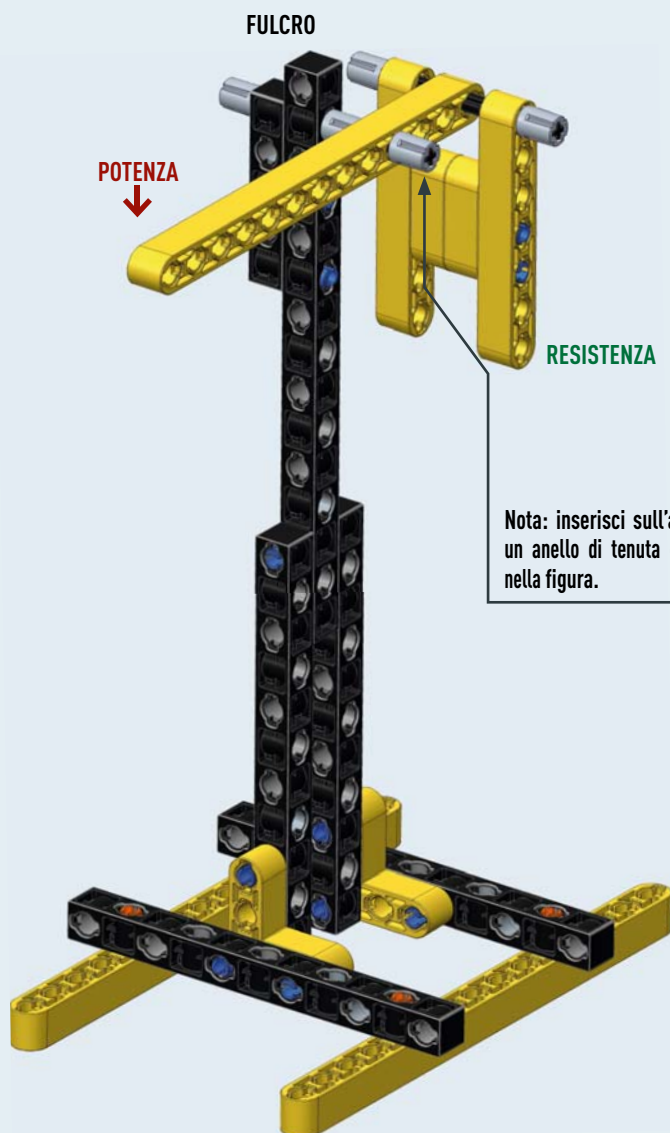

Modello finale

Trova l'equilibrio in questo tipo di strumento: poni il peso (**RESISTENZA**) da una parte della leva e premi con la mano (**POTENZA**) dall'altra parte, fai attenzione alla pressione che eserciti.

Osserva la posizione del fulcro!

- I bracci sono uguali.
- La **POTENZA** è uguale alla **RESISTENZA**.

SPERIMENTA!

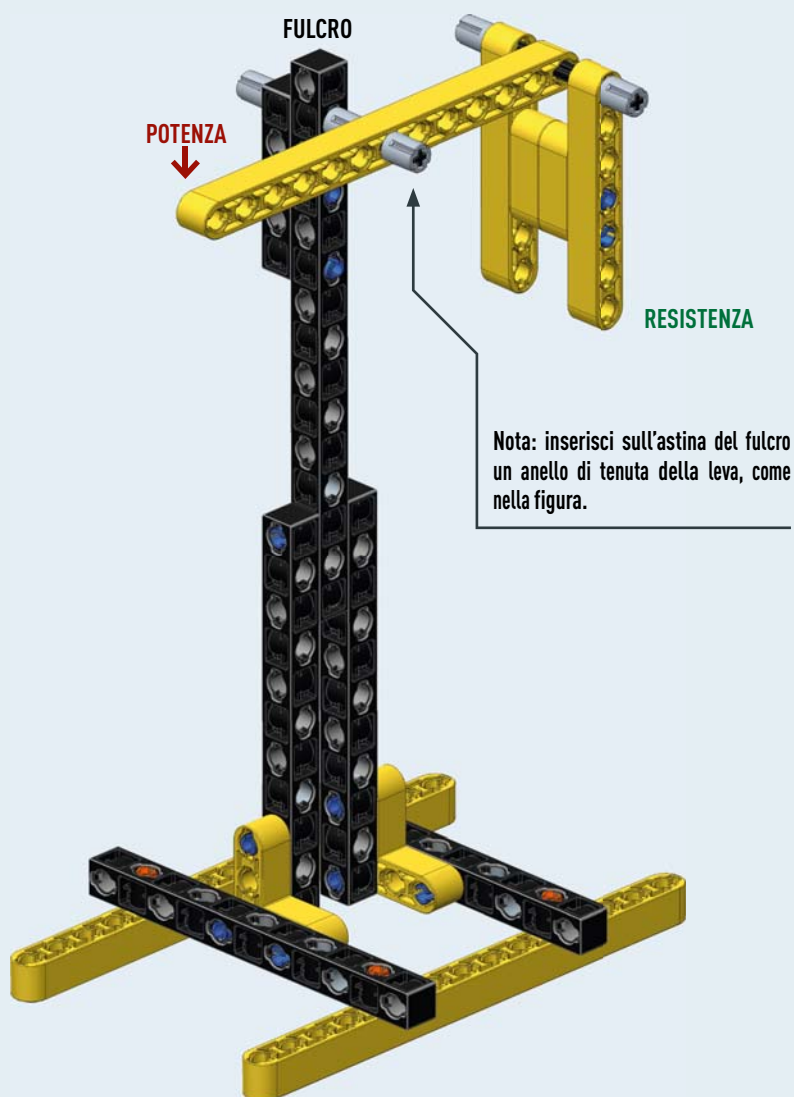

Modello finale

Trova l'equilibrio in questo tipo di strumento: poni il peso (**RESISTENZA**) da una parte della leva e premi con la mano (**POTENZA**) dall'altra parte, fai attenzione alla pressione che eserciti.

Osserva la posizione del fulcro!

- I bracci sono uguali.
- La **POTENZA** è uguale alla **RESISTENZA**.

SPERIMENTA!

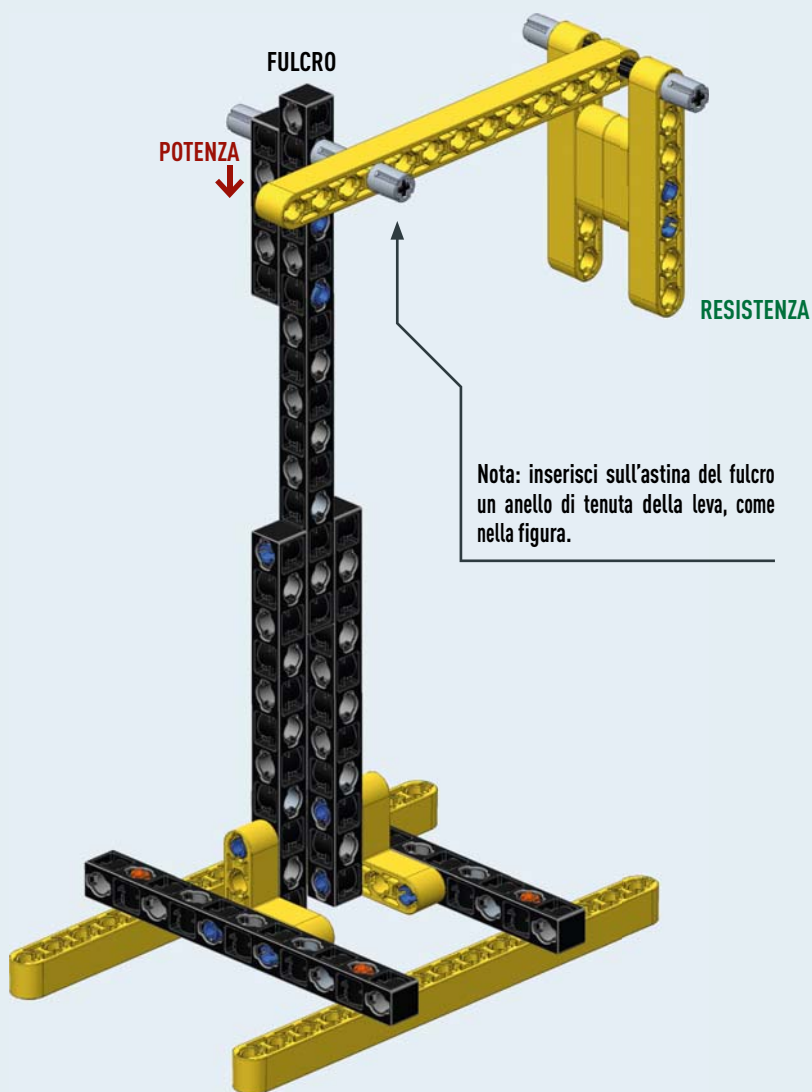

Modello finale

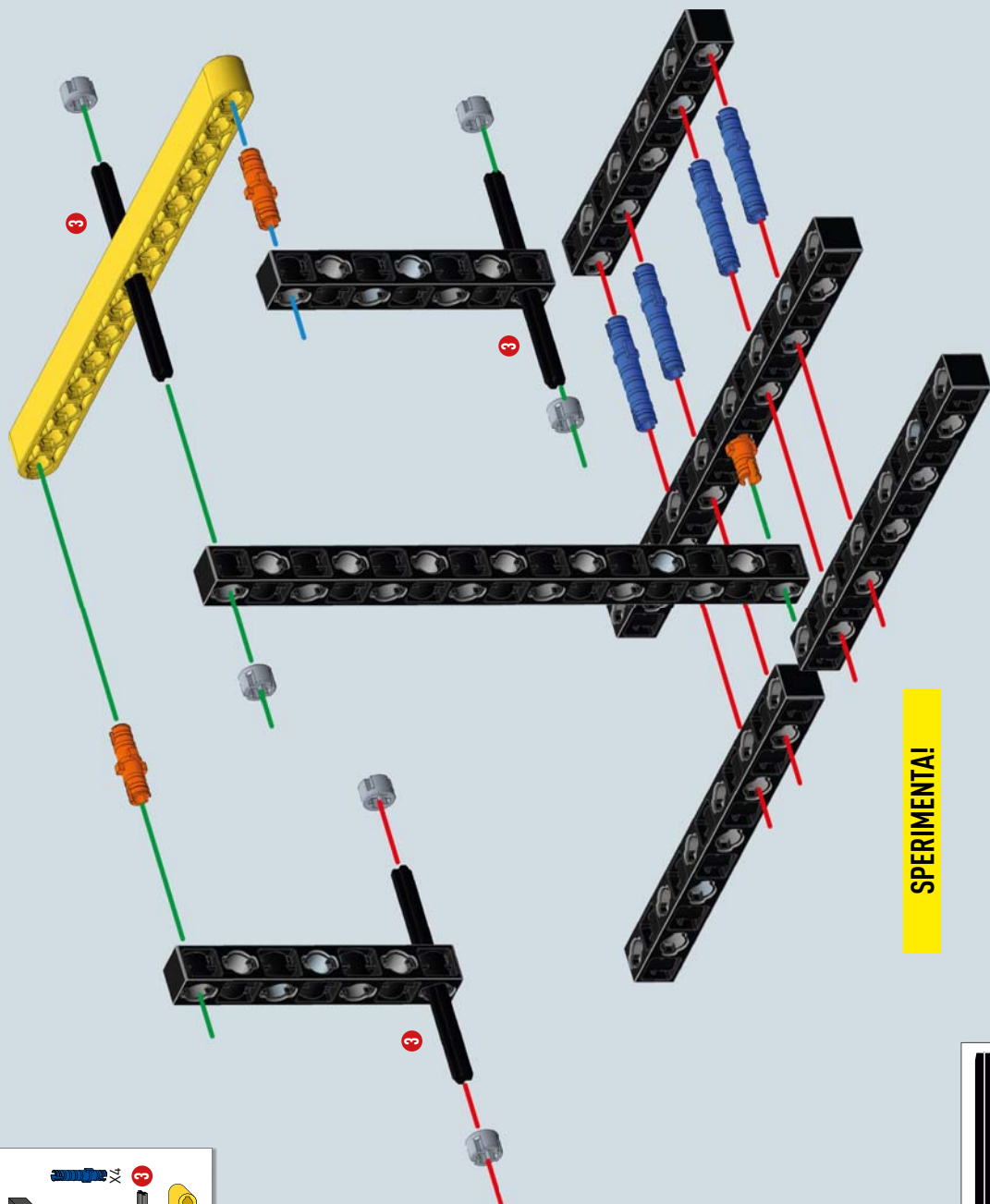
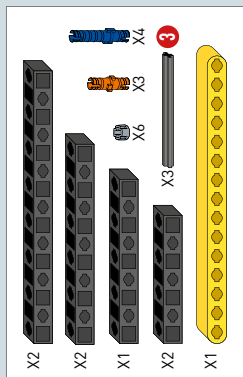

La bilancia è una leva di 1° genere



Modello finale

SPERIMENTA!





- X2
- X2
- X2
- X2
- X4
- X2
- X6
- 2
- 3

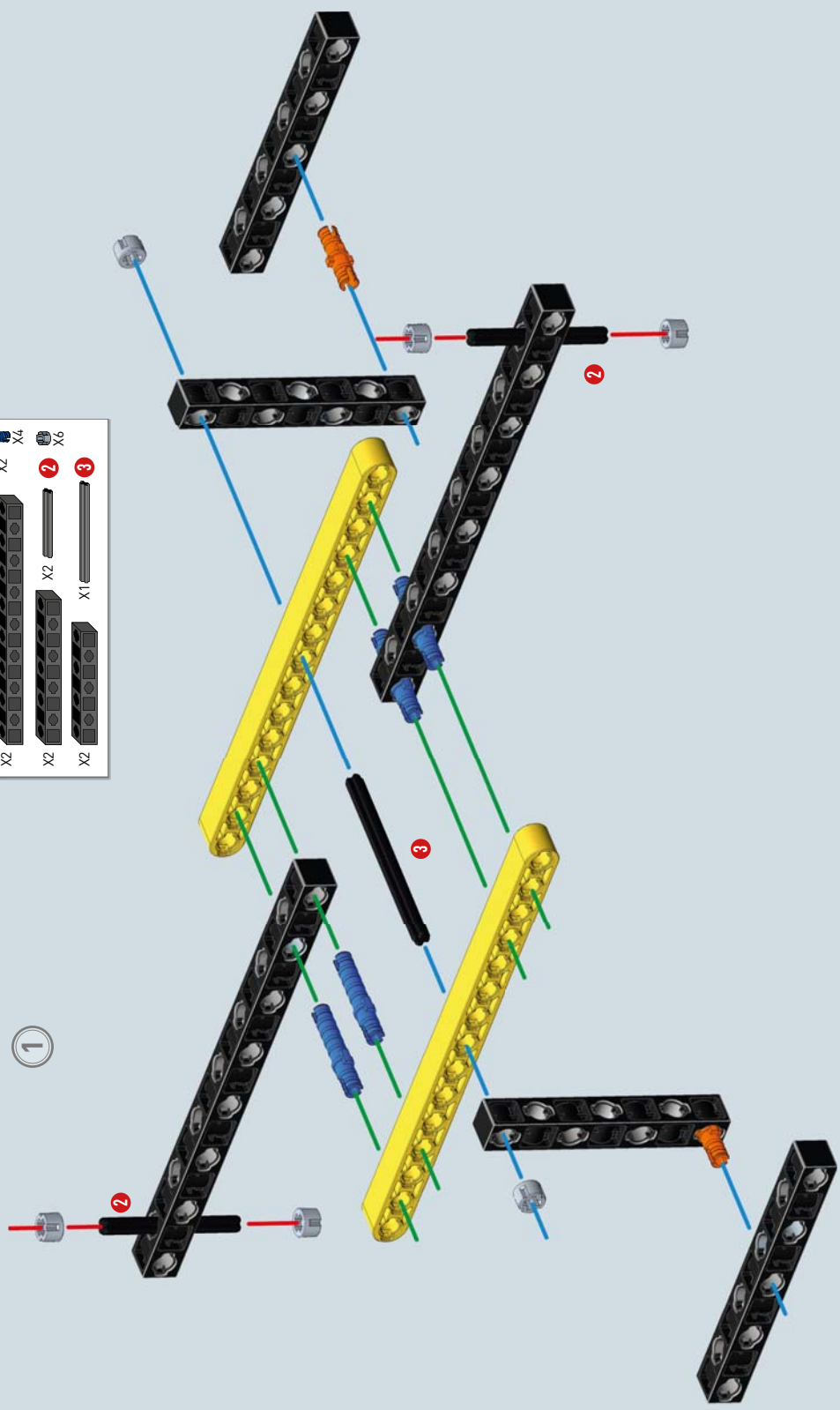

2

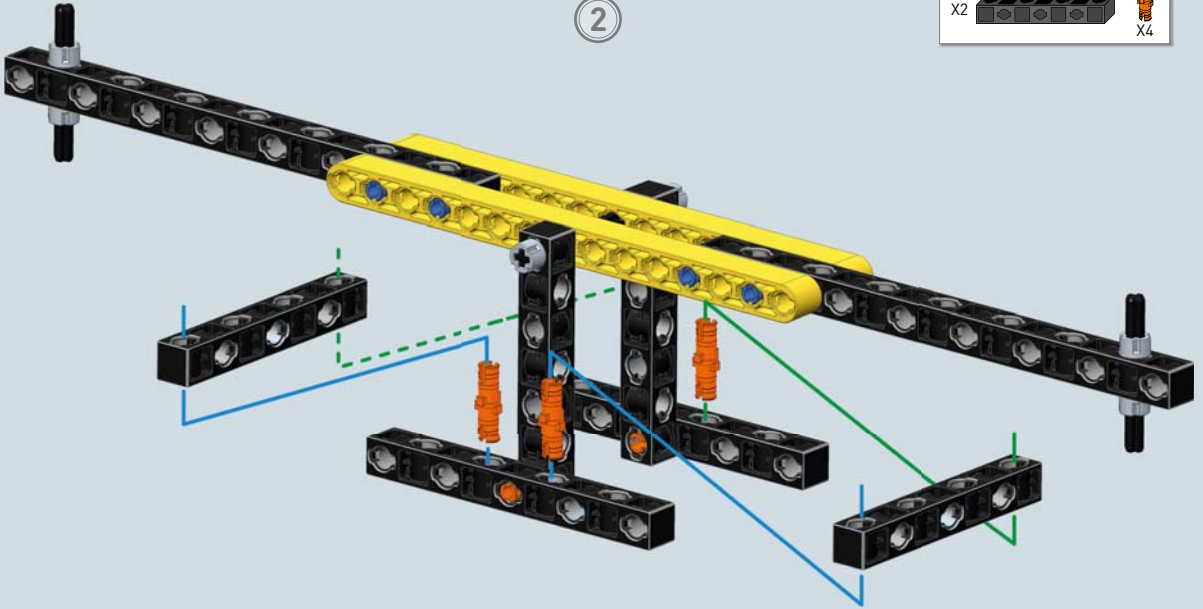
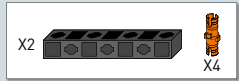

Archimede nel III secolo a.C. fu un grande scienziato e sperimentatore con le leve.

Nota: la leva dell'altalena deve ruotare liberamente intorno al fulcro.

Prova anche tu: ricerca l'equilibrio dell'altalena variando i pesi, le distanze dal fulcro della Resistenza e della Potenza.

SPERIMENTA!

L'altalena è una leva di 1° genere



Modello finale

Le ruote dentate servono a trasmettere il movimento tra assi (astine) poste in maniera particolare; sono i denti a dare il movimento.

- In una coppia di ruote dentate, se una gira in un senso l'altra gira nel senso opposto; delle due ruote una trasmette il moto (ruota motrice) l'altra lo riceve (ruota condotta).
- Volendo mantenere lo stesso verso di rotazione occorre *inserire una terza ruota dentata tra le due*.
- Con ruote dentate diverse la più piccola, con pochi denti, si chiama **pignone**, l'altra con tanti denti, **corona**. Più ruote dentate costituiscono gli ingranaggi.

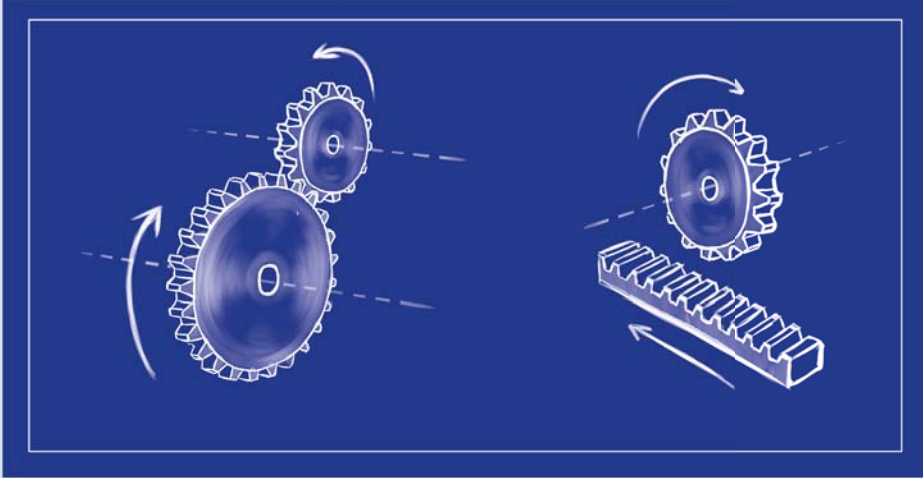

23 Assembla il banco di prova per la rotazione inversa

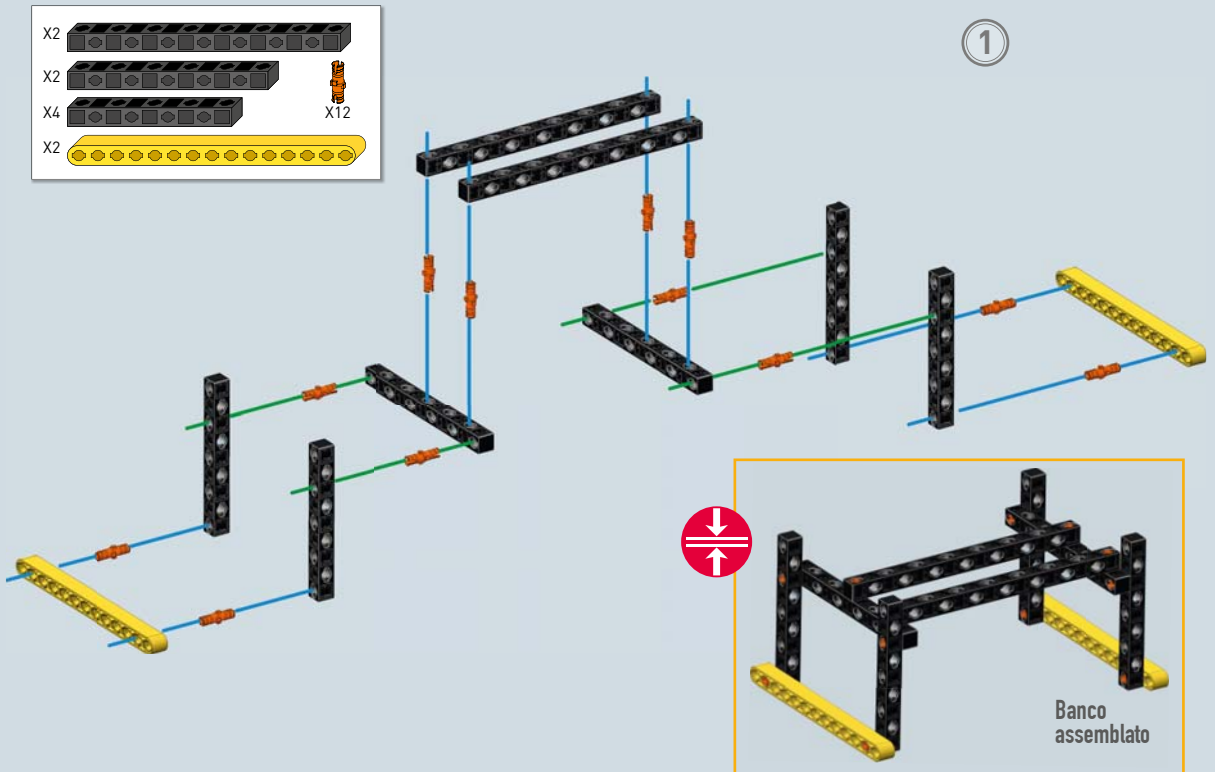

2

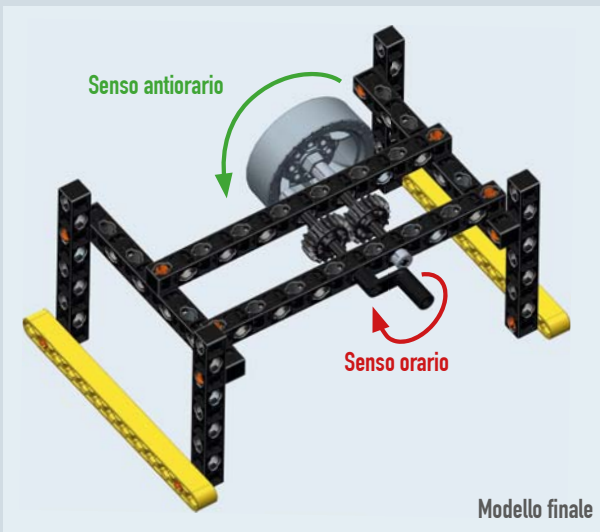
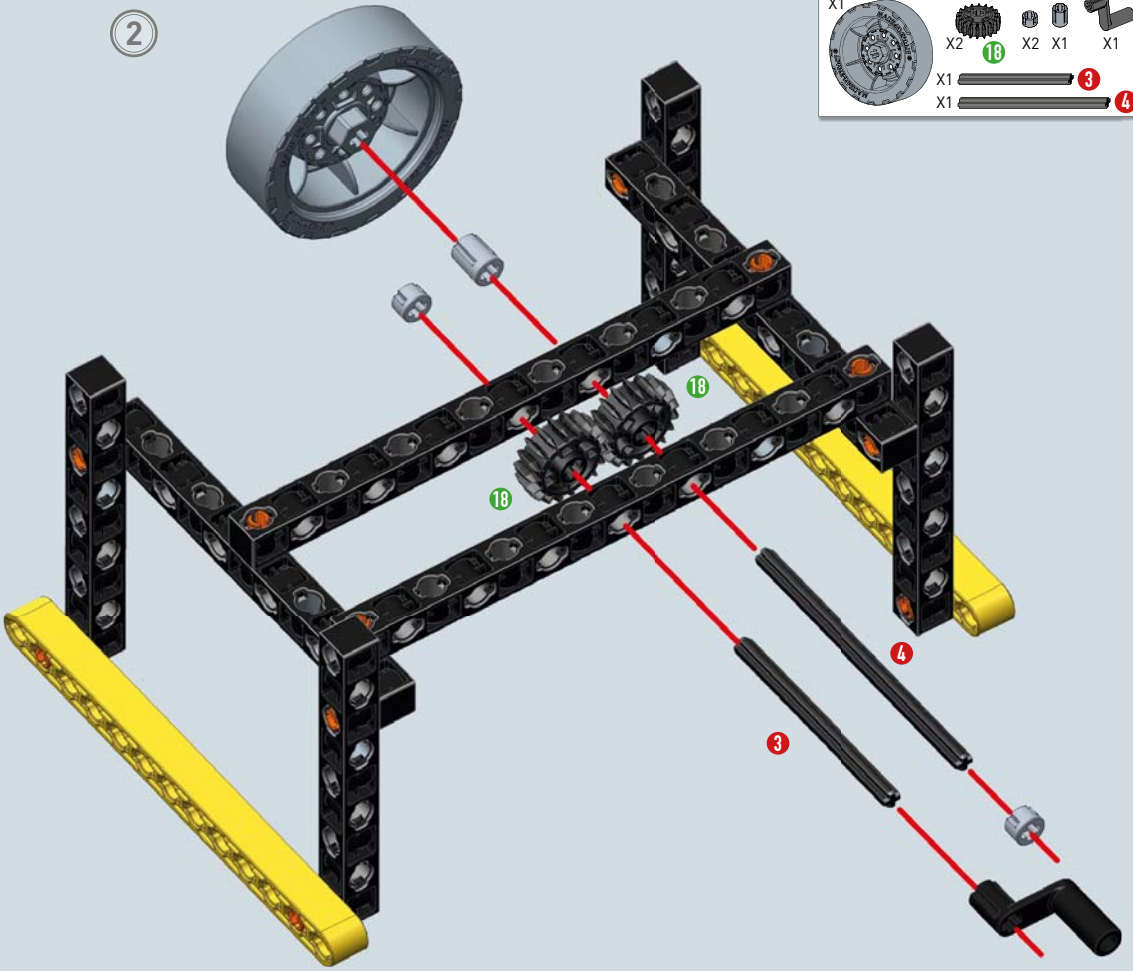
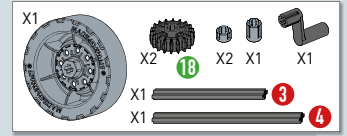

Modello finale



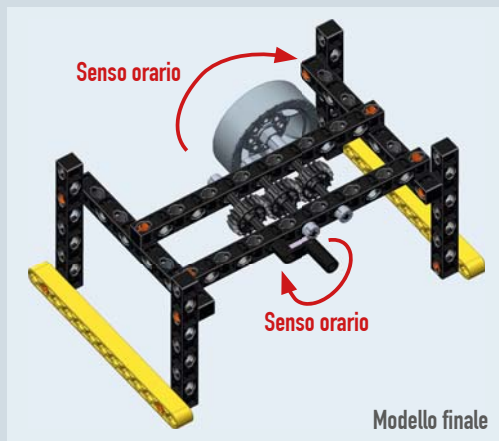
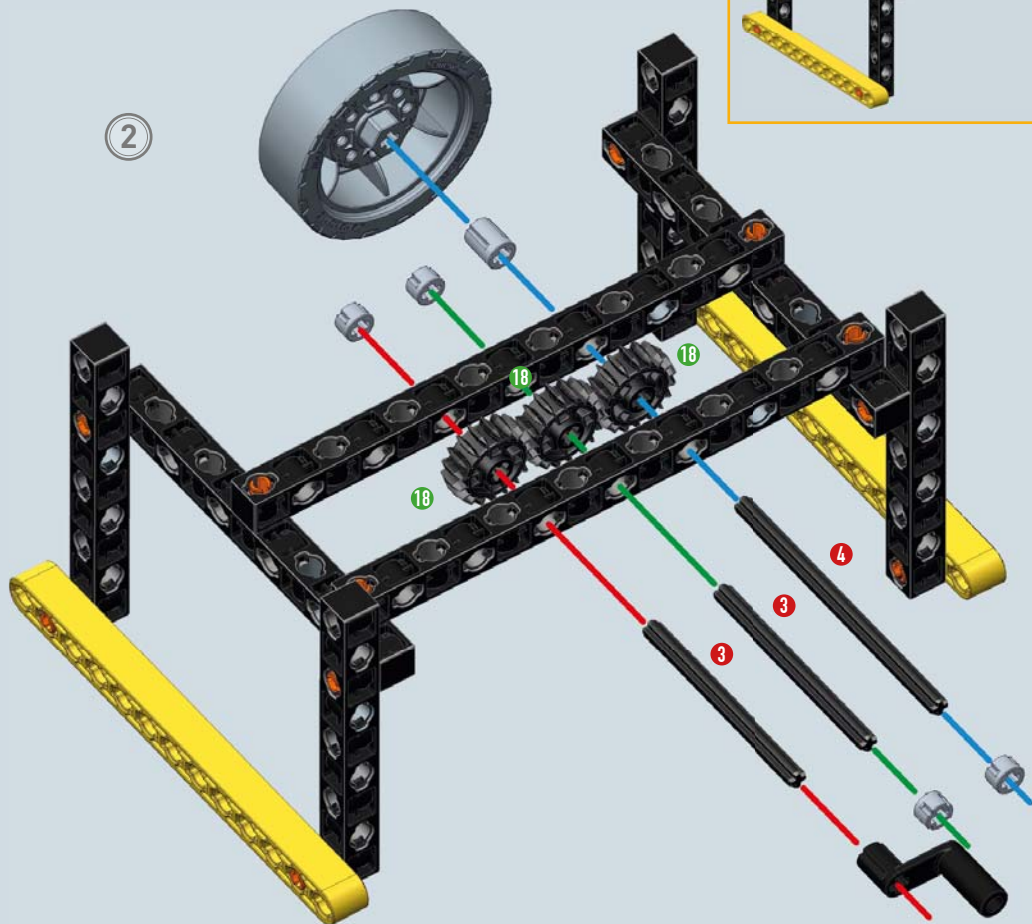
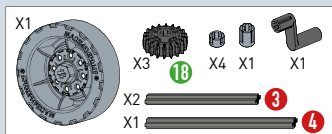

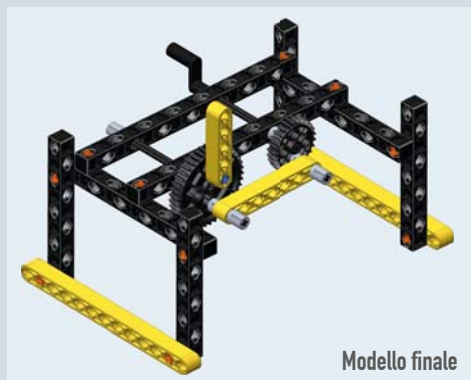
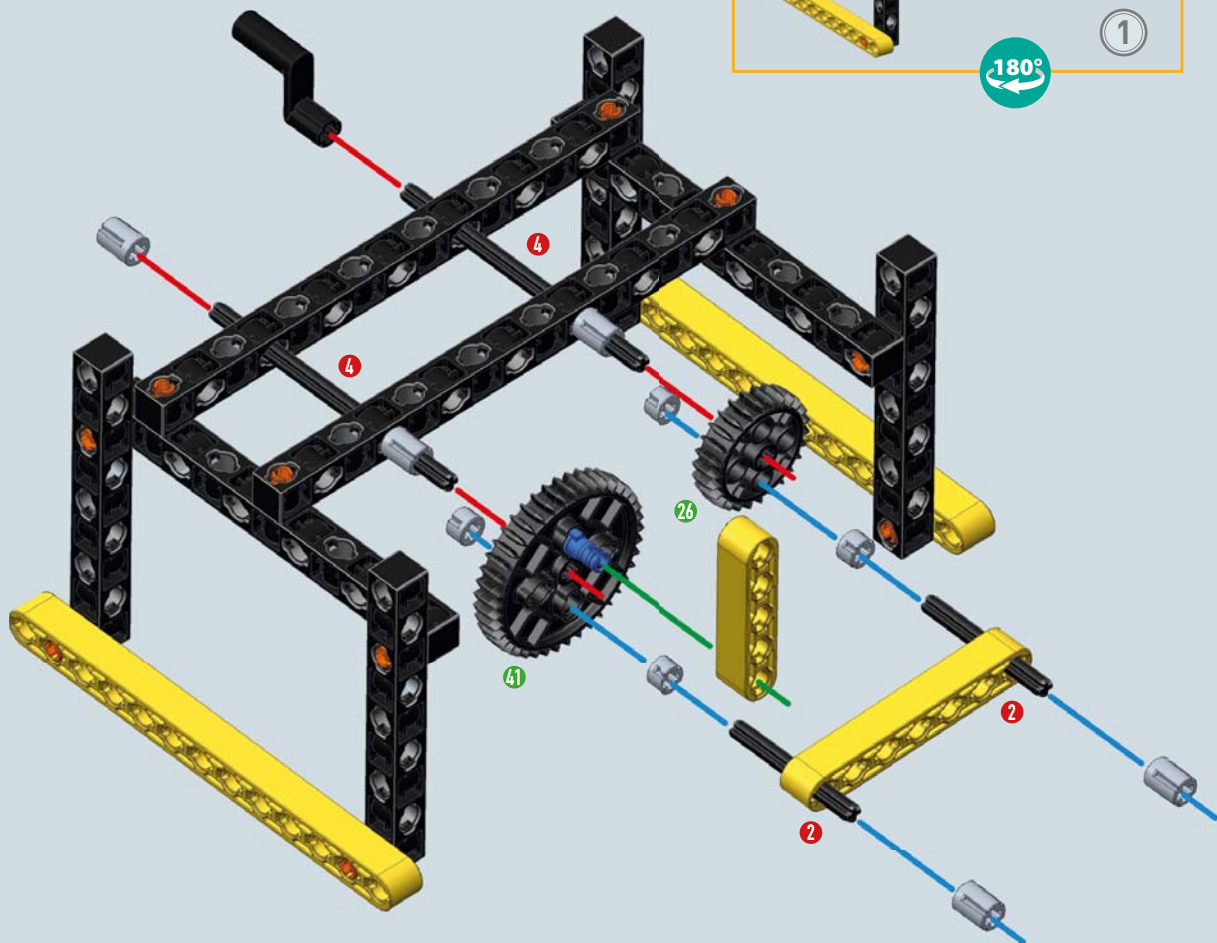
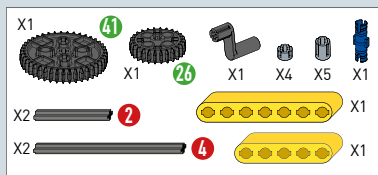

Banco assemblato nell'attività n° 23



1

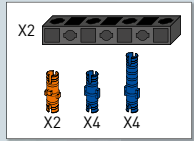

2

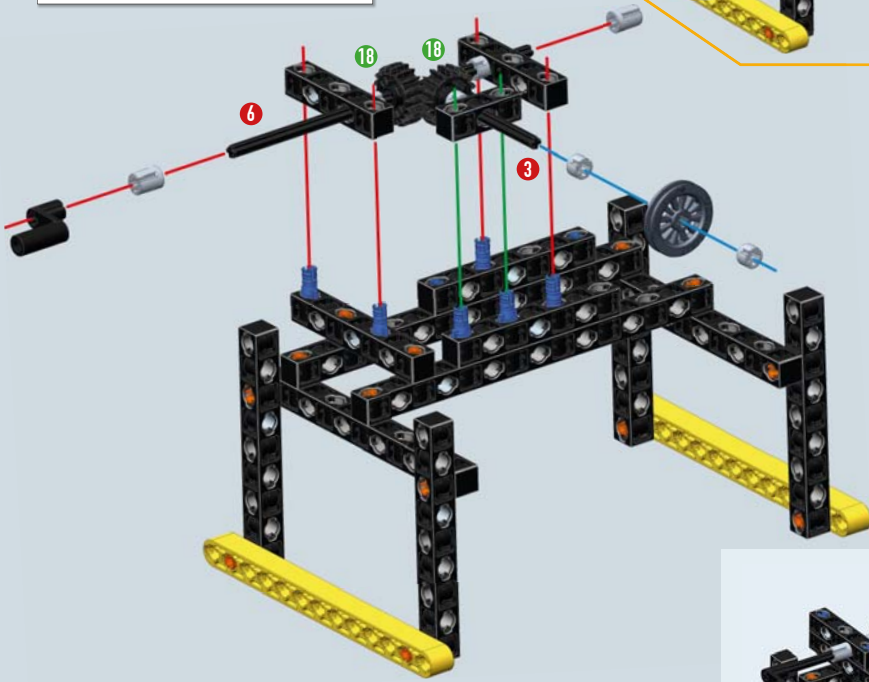
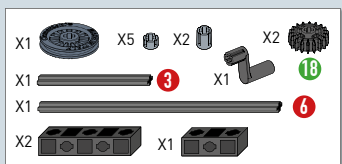
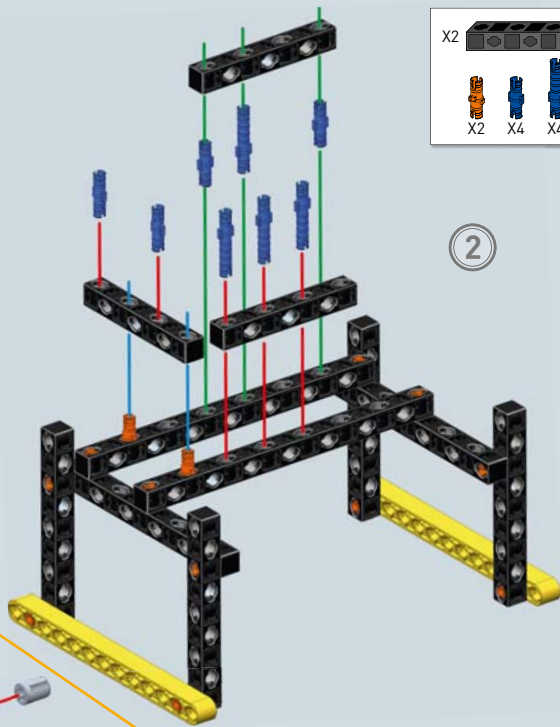

Le due ruote dentate devono incastrarsi ad angolo retto, con le due astine quasi a contatto.

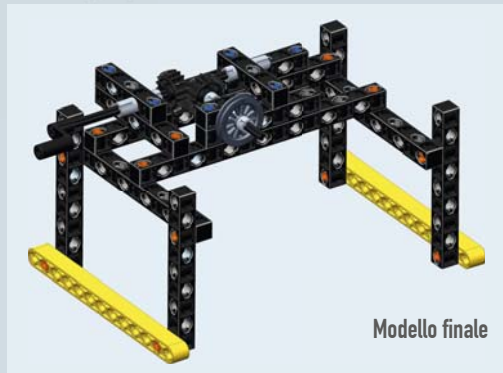

Modello finale

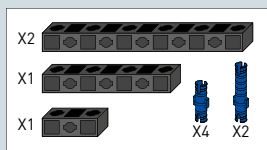

2

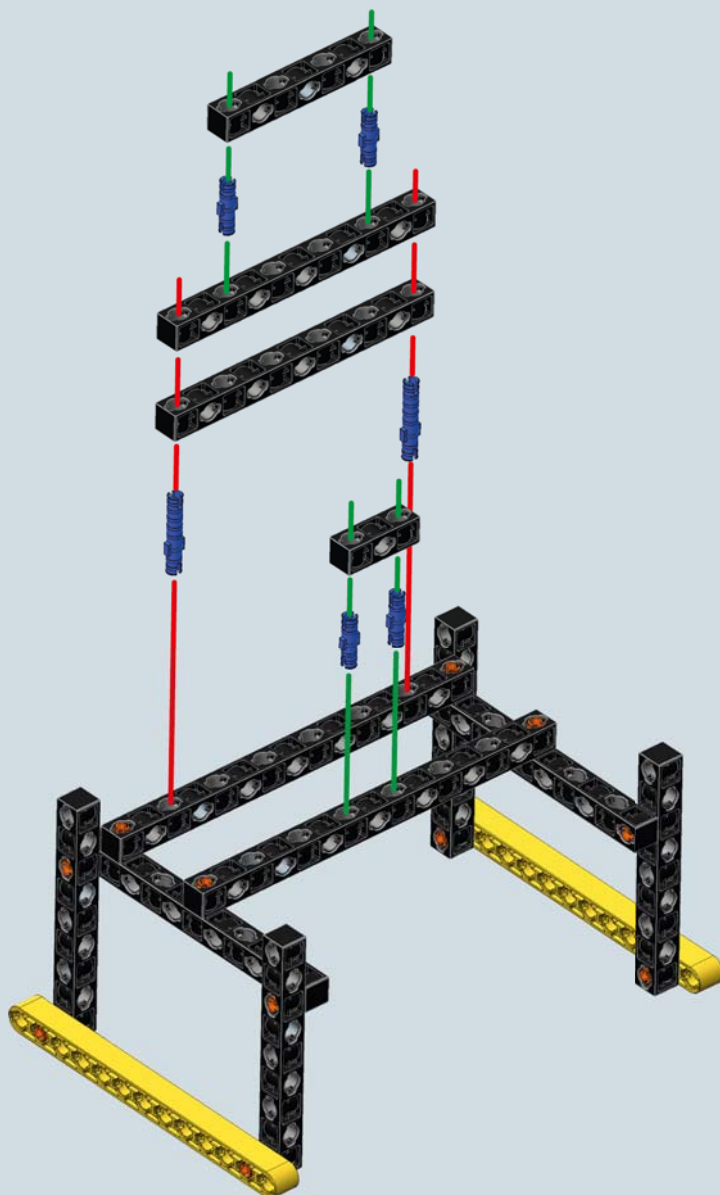

1

3

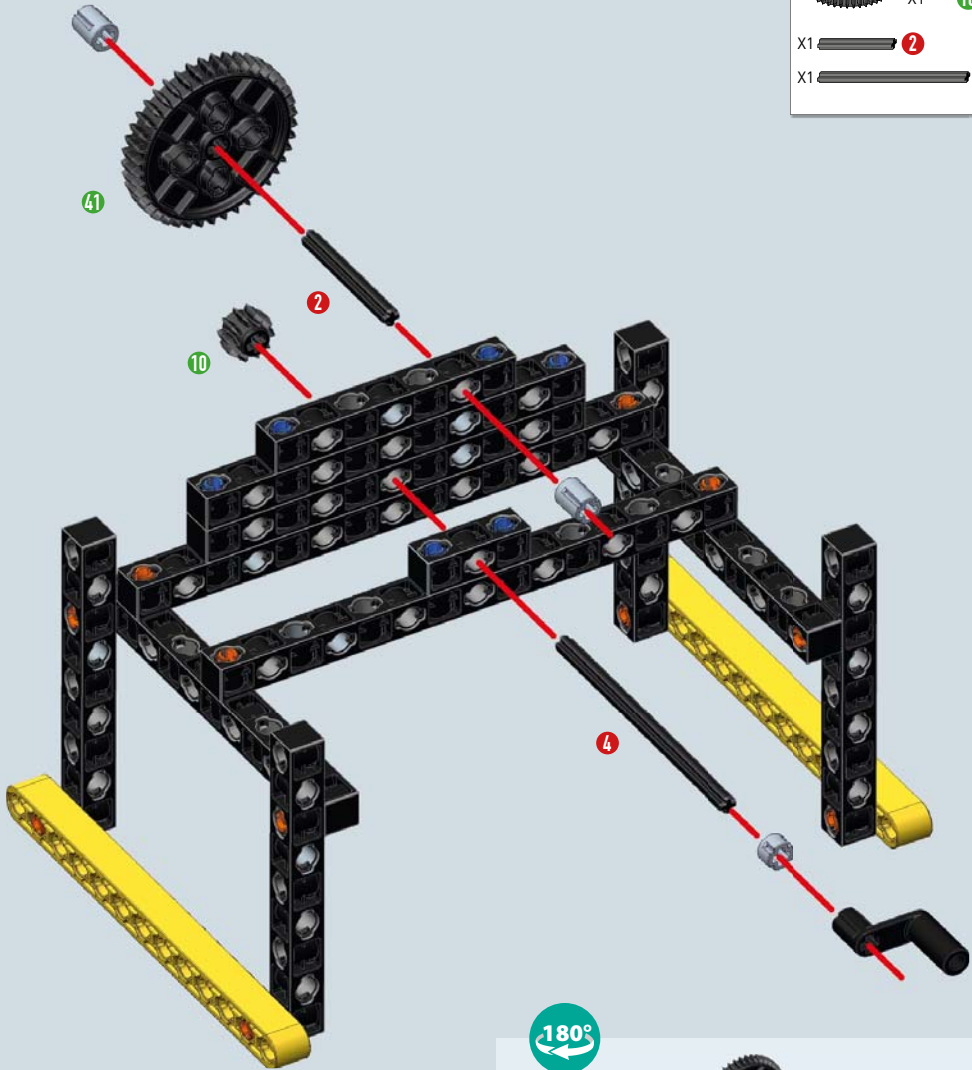

X1		41	X1		10	X1		2
X1		2	X1		10	X1		4
X1		4	X2		2	X2		4

180°

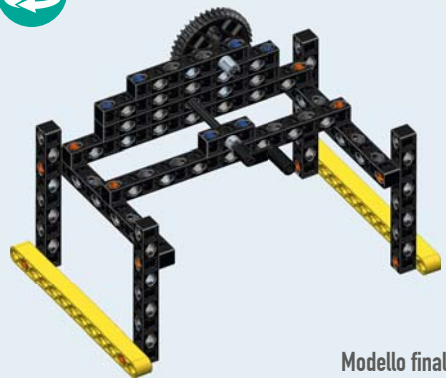

Modello finale



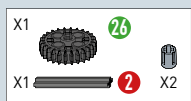

2

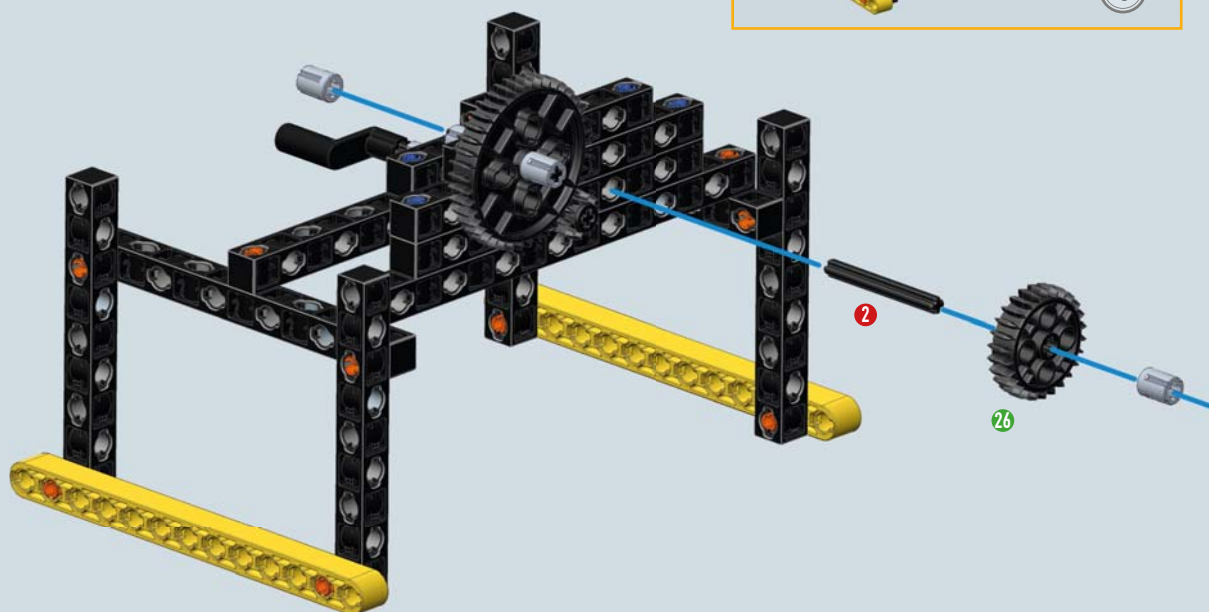

RAPPORTO DI TRASMISSIONE

Osserva attentamente le ruote dentate quando girano e confronta i giri compiuti dalle diverse ruote. Quando la ruota più grande ha compiuto un giro la più piccola ne ha completati 4. In questo caso potresti avere la conferma facendo la divisione o il rapporto tra il numero di denti delle due ruote dentate.

Esempio: come calcolare il rapporto di trasmissione.

$$\frac{41 \text{ denti (ruota più grande)}}{10 \text{ denti (ruota più piccola)}} = 4,1 \text{ giri}$$

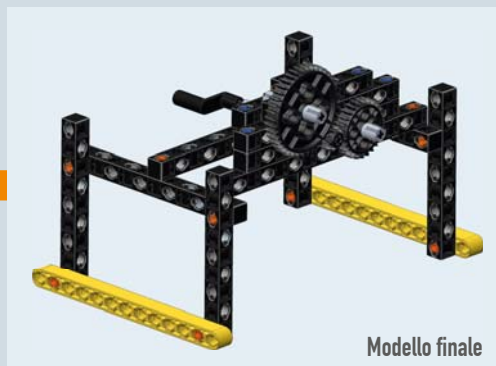

Modello finale



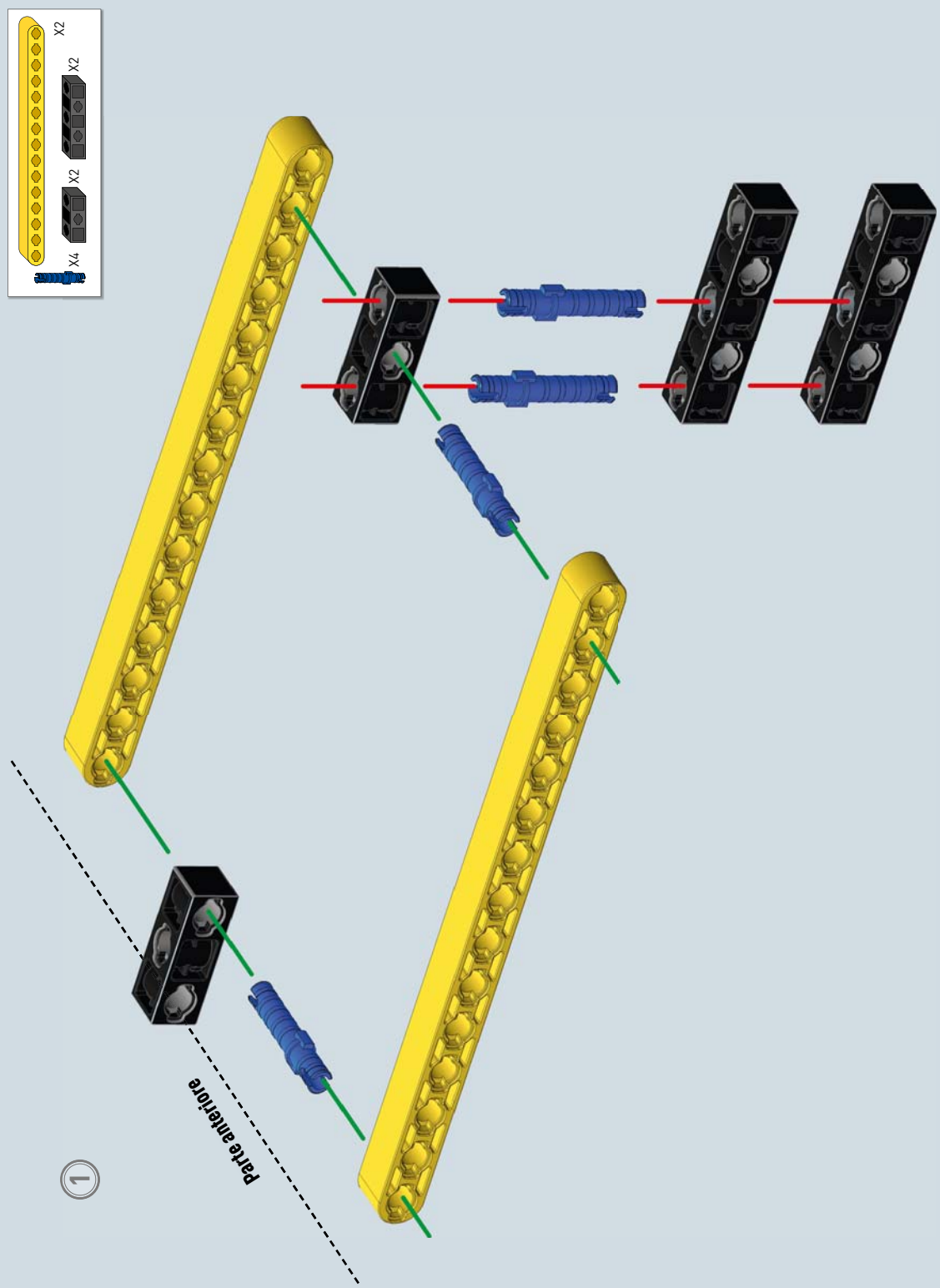

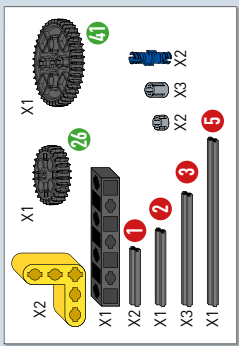
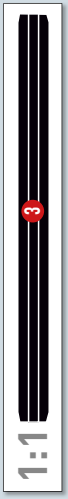
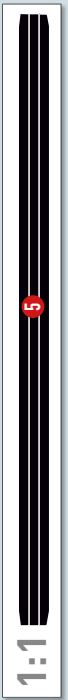
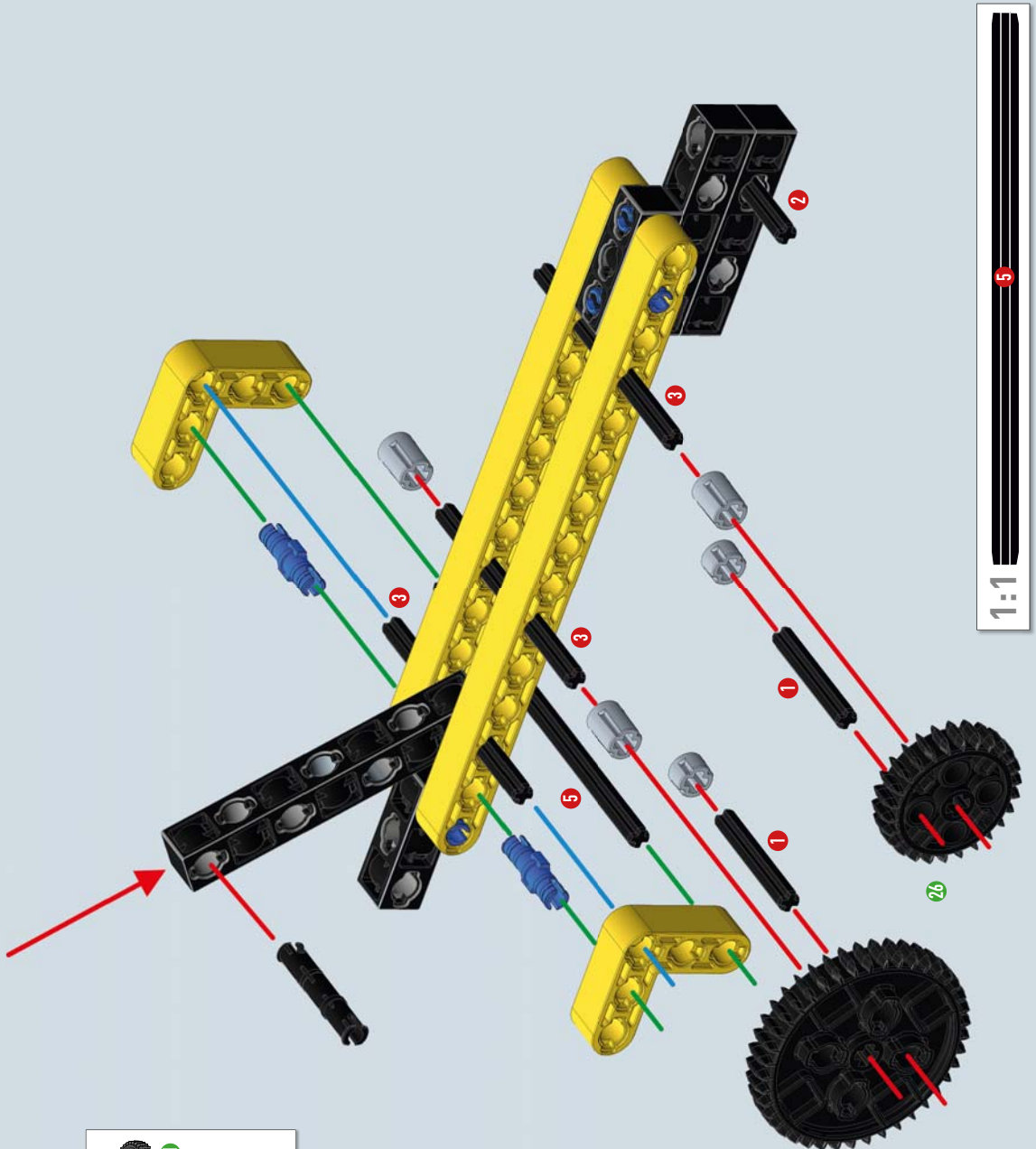

2

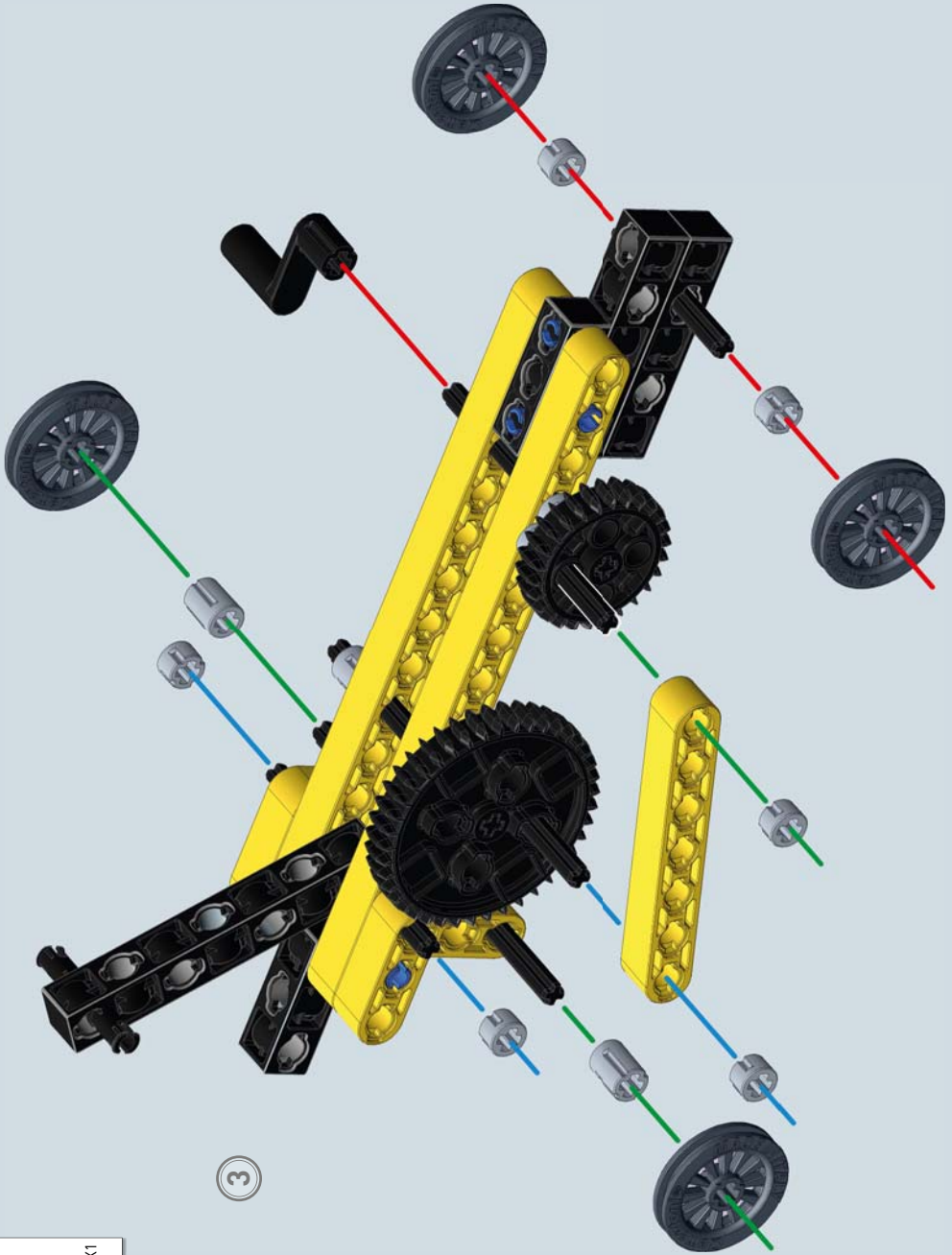

3

	X1		X1
	X2		
	X6		X4

4

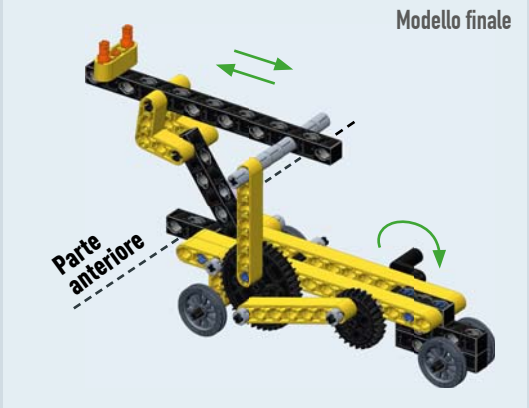
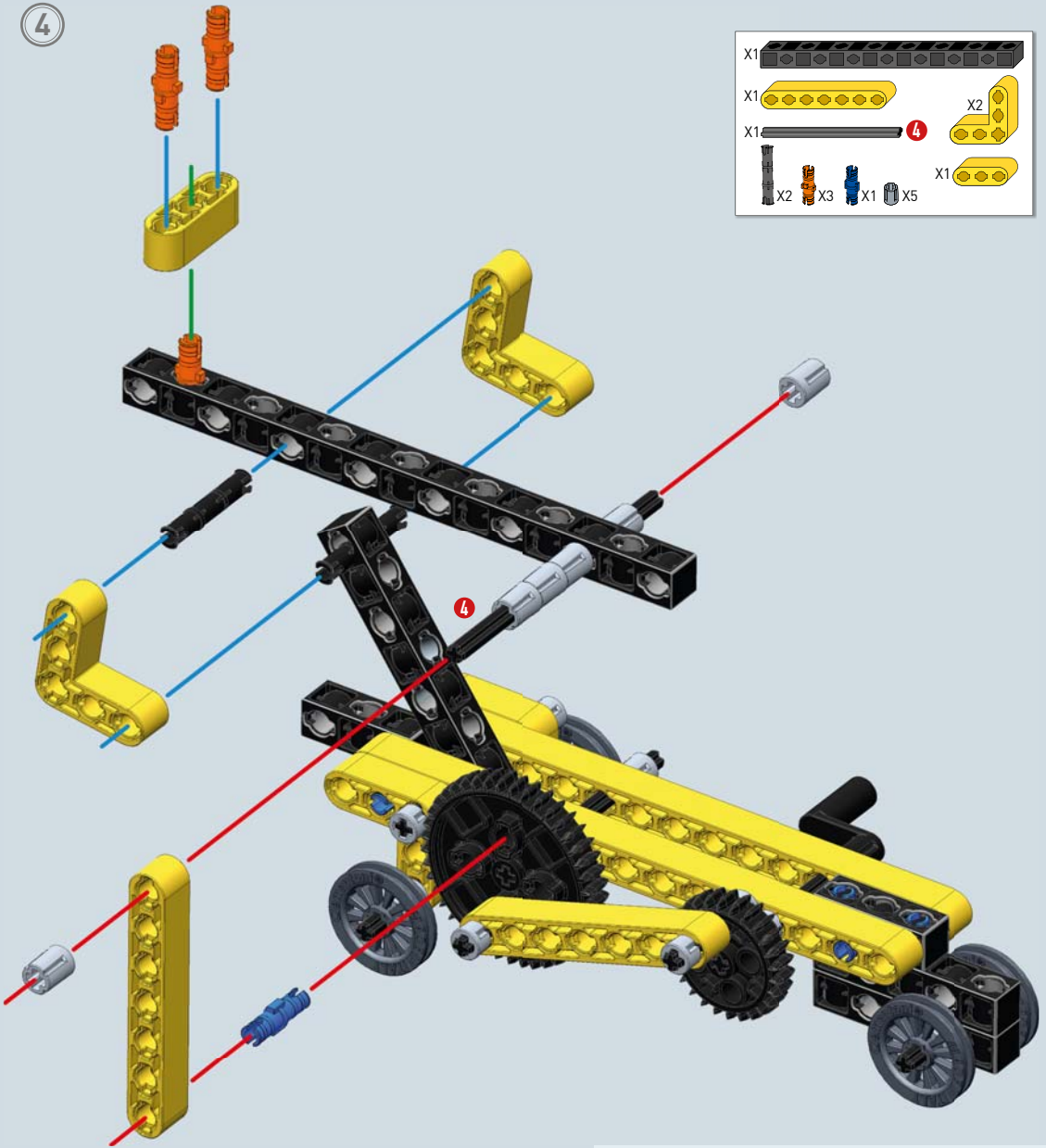



- X2 6
- X1 4
- X1 X1 26
- X2 X1 10
- X1 X4 X2 18
- X2 X4 18

1

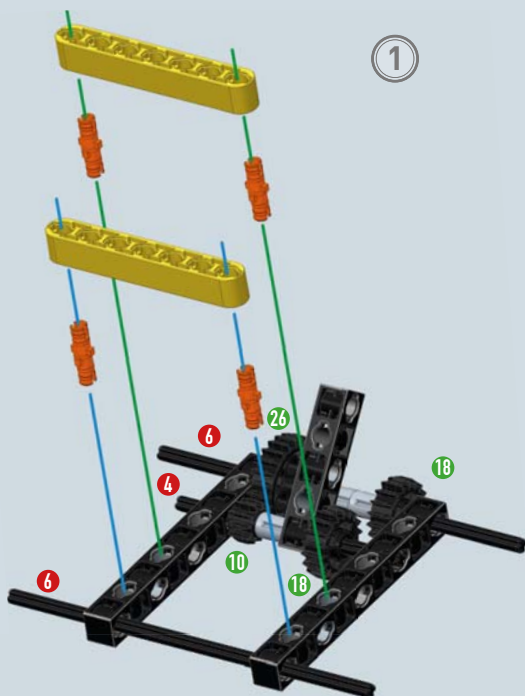

2

- X4 X4
- X4 X4

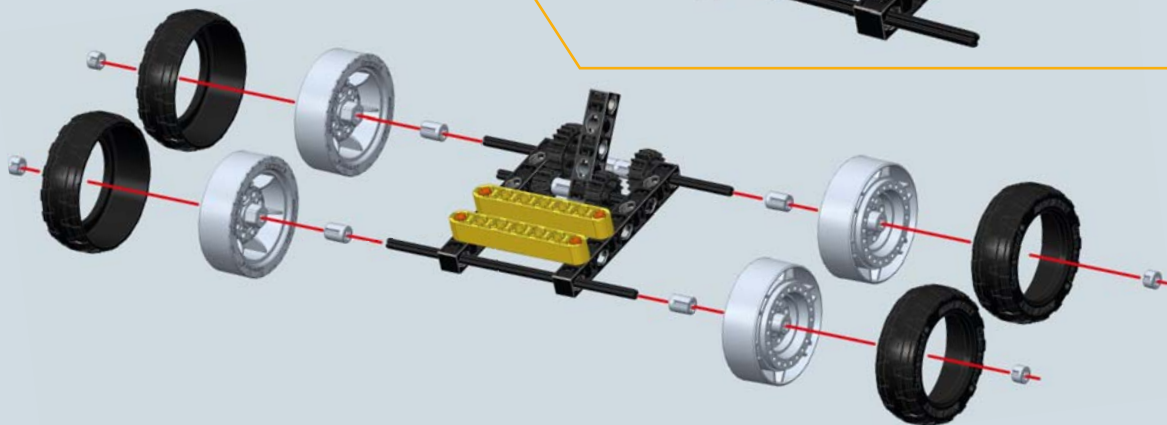

Leva del cambio

Velocità
1° ↔ 2°

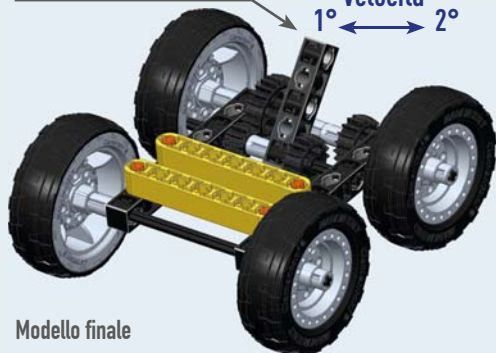

Modello finale

Notizie tecniche sul cambio meccanico di velocità

Nella realtà delle vetture, gli ingranaggi sono ben chiusi in una scatola, detta del cambio, posta tra l'asse del motore e l'asse delle ruote.

Modo di variare la marcia

Spostando orizzontalmente con la leva (vedi fig.) le ruote dentate dell'asse del cambio che presentano più o meno denti, si ha la possibilità di farle incontrare con le ruote dentate dell'asse delle ruote. Si genera così, a seconda della ruota trainante, una variazione di rotazione delle ruote e quindi una variazione di velocità dell'auto.