

1

scienza
gioco &

TECNOLOGICA

Laboratorio di MECCANICA

MEZZI DI SOCCORSO

Costruzioni da **1 a 3**

- 1 - L'UTV per il soccorso in spiaggia
- 2 - L'hovercraft
- 3 - Il carro attrezzi

AVVISO

Per garantire un adeguato funzionamento del motore elettrico, durante la produzione è stata aggiunta una piccola quantità di grasso. In presenza di temperature elevate tale sostanza può sciogliersi divenendo untuosa.

Nel caso in cui il motore contenuto nel kit sia sporco, puoi semplicemente pulirlo con delle salviette.

Il grasso utilizzato non è né tossico, né pericoloso.

ATTENZIONE!

Solo per bambini di 8 anni e oltre.

Le istruzioni per gli adulti sono incluse e devono essere rispettate.

Manuale da leggere e conservare per future referenze.

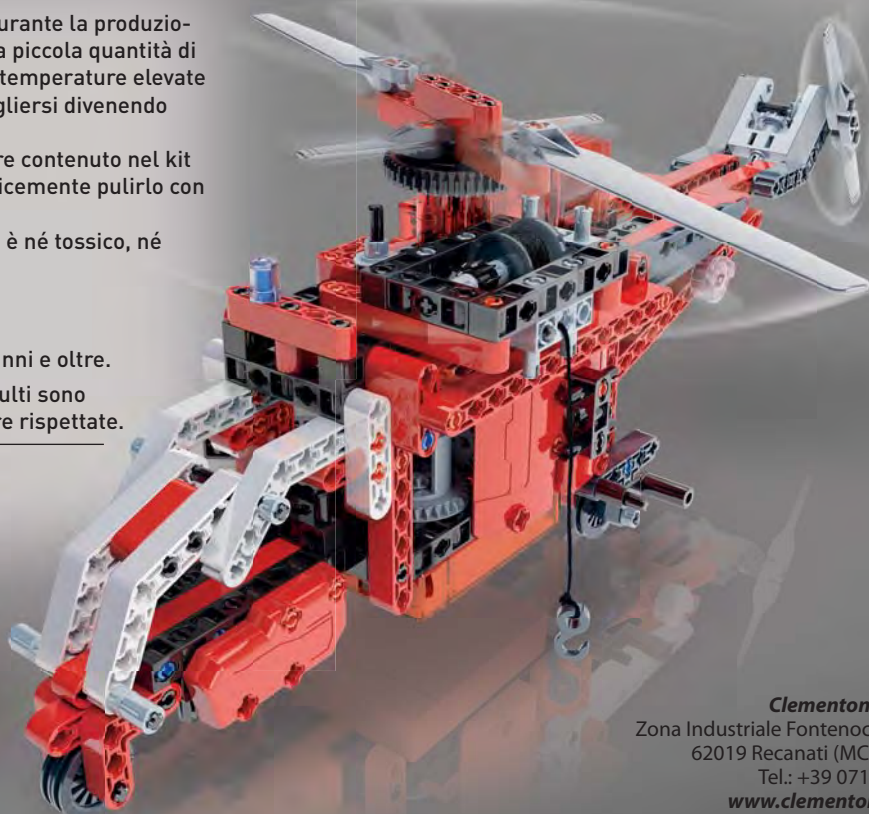

V38493



Assistenza clienti

Tel. 02.82.52.52

Email - assistenza@clementoni.it

 **Clementoni**[®]

Clementoni S.p.A.
Zona Industriale Fontenoce s.n.c.
62019 Recanati (MC) - Italy
Tel.: +39 071 75811
www.clementoni.com

ISTRUZIONI PER GLI ADULTI CHE SURVEGLIANO: questo gioco è adatto ai bambini dagli 8 anni in su. Per il montaggio dello strumento e durante la manipolazione ed installazione degli elementi elettrici si raccomanda la presenza di un adulto.

RIMOZIONE E INSTALLAZIONE DELLE BATTERIE

Assicuratevi che l'apparecchio sia spento.

- 1 Utilizzate un cacciavite universale per svitare la vite che fissa il coperchio del vano batterie.
- 2 Rimuovete le batterie esaurite.
- 3 Inserite (4 x 1,5V AA/LR6) secondo il segno di polarità indicato nel vano stesso.
- 4 Le batterie devono essere inserite da un adulto.
- 5 Richiudete il coperchio del vano, stringendo la vite.
- 6 Assicuratevi che l'apparecchio funzioni.

COME INSERIRE LE BATTERIE

Chiedi aiuto ad un adulto!

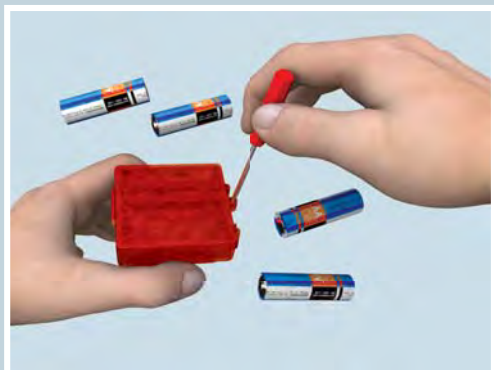

Alimentazione: d.c. 6V

Batterie: 4 x 1,5V AA/LR6

Le batterie non sono incluse.

ALTRE RACCOMANDAZIONI:

- Le batterie sono pericolose se inghiottite, quindi tenerle lontano dalla portata dei bambini.
- Rimuovere le batterie qualora il gioco non venga utilizzato per un lungo periodo.
- Non tentare di aprire le batterie.
- Non gettare le batterie nel fuoco.

INDICAZIONI PER IL CORRETTO UTILIZZO DEI GIOCHI CON BATTERIE SOSTITUIBILI

ATTENZIONE!

- Le batterie devono essere inserite rispettando la corretta polarità + e - contrassegnata sulle batterie stesse.
- Le batterie scariche devono essere rimosse dal gioco.
- I morsetti di alimentazione non devono essere cortocircuitati.
- Non toccate in alcun modo i contatti all'interno del vano batterie per evitare possibili corto-circuiti.
- Le batterie ricaricabili vanno rimosse prima di essere ricaricate, effettuare la ricarica solo sotto la supervisione di un adulto.
- Le batterie non ricaricabili non devono essere ricaricate.
- Diversi tipi di batterie o batterie nuove e usate non devono essere mischiate.

ISTRUZIONI PER LO SMALTIMENTO DELLE BATTERIE



Il simbolo indica che le batterie esauste devono essere trattate in rispetto delle normative ambientali in vigore. I simboli chimici relativi a mercurio (Hg), cadmio (Cd) e/o piombo (Pb) che compaiono sotto il simbolo del bidone barrato indicano la presenza nella batteria di una significativa percentuale della sostanza indicata. Tali sostanze sono altamente dannose per l'ambiente e per la salute umana. Il corretto smaltimento delle batterie permette l'isolamento e il trattamento mirato delle sostanze nocive e consente il riciclaggio delle materie prime pregiate diminuendo gli effetti negativi sulle persone e sull'ambiente. Gettare le pile esauste in discarica o nell'ambiente aumenta notevolmente il rischio di inquinamento delle acque.

Ai sensi della Direttiva Europea 2013/56/UE è vietato smaltire pile e accumulatori come rifiuti urbani ed è fatto obbligo ai consumatori di partecipare alla raccolta differenziata in modo da agevolare il trattamento e il riciclaggio degli stessi.

COME SMALTIRE LE BATTERIE:

- Prima di gettare le batterie, scaricarle completamente attivando l'apparecchio fino al completo esaurimento delle stesse.
- Rimuovere le batterie dall'apparecchio prima dello smaltimento.
- Smaltire le batterie in conformità alle normative vigenti conferendole negli appositi contenitori laddove disponibili o presso un centro di raccolta autorizzato o presso il punto vendita dove è stato effettuato l'acquisto. La restituzione è gratuita!
- Sono previste sanzioni in caso di smaltimento abusivo.

ISTRUZIONI PER LO SMALTIMENTO DI APPARECCHIATURE ELETTRICHE ED ELETTRONICHE SOGGETTE A RACCOLTA DIFFERENZIATA

IMPORTANTE! Il simbolo del bidone  barrato indica che nei paesi dell'Unione Europea (Dir.2012/19/UE) ed in quelli che adottano sistemi di raccolta differenziata tutti i componenti del prodotto contrassegnati da questo simbolo (o in tal modo indicati nelle istruzioni del gioco) sono soggetti all'obbligo di raccolta differenziata alla fine del loro ciclo di vita. È vietato smaltire tali componenti come rifiuti urbani misti.

COME SMALTIRE LE AEE:

- È obbligatorio raccogliere separatamente solo i componenti contrassegnati con il simbolo  (o indicate nella documentazione come soggette) e conferirli agli appositi centri di raccolta allo scopo istituiti o, ove consentito, restituire il prodotto di cui ci si vuole disfare al proprio negoziante all'atto dell'acquisto di un prodotto analogo o a titolo gratuito nel caso in cui le dimensioni esterne del componente siano inferiori ai 25 cm.
- Gli utilizzatori del prodotto svolgono un ruolo determinante per favorire il corretto smaltimento delle apparecchiature elettriche ed elettroniche giunte a fine vita. È pertanto importante che ciascun utilizzatore sia consapevole del proprio ruolo e smaltisca sempre i rifiuti elettrici/elettronici nel rispetto della normativa vigente, contribuendo in questo modo ad una loro corretta gestione e favorendo il loro riutilizzo, riciclaggio e/o recupero.

ATTENZIONE!

- i componenti contrassegnati con il simbolo  contengono sostanze nocive per l'ambiente e la salute umana pertanto è vietato smaltirli come rifiuto urbano indifferenziato o con gli altri rifiuti domestici. Uno smaltimento non corretto può comportare danni per l'ambiente ed è sanzionato a termini di legge.
- È vietato utilizzare tali componenti in maniera impropria ed in particolare è vietato smontare le componenti elettriche ed elettroniche del gioco ed utilizzarlo se danneggiato. Tali comportamenti potrebbero provocare danni alla salute.

N.B.: Quanto sopra riportato riguarda esclusivamente le componenti del gioco contrassegnate (o indicate nella documentazione come soggette) con il simbolo .

Gli altri componenti del gioco (schede, accessori ecc.) e la confezione non sono soggetti alle indicazioni sopra riportate e devono essere smaltiti secondo le modalità previste dalle norme vigenti. Tali altri componenti non devono essere conferiti ai centri di raccolta delle apparecchiature elettriche ed elettroniche o restituiti al rivenditore all'atto dell'acquisto di un nuovo prodotto.

Gli utenti domestici (non professionali) sono invitati a contattare il proprio rivenditore, gli uffici pubblici preposti allo smaltimento dei rifiuti o il Servizio Clienti della: **CLEMENTONI S.p.A. (Tel.+39 071 75811; fax +39 071 7581234; e-mail: info@clementoni.it)** per tutte le informazioni inerenti il corretto smaltimento del prodotto.

 iscrizione Registro produttori apparecchiature elettriche o elettroniche n° IT0801000000019 del 10/01/2008



Prova a costruire i tuoi modelli con l'App del laboratorio di meccanica. Le animazioni interattive ti guideranno nell'assemblaggio in maniera semplice e divertente.



IL DIVERTIMENTO CONTINUA CON 35 ATTIVITÀ DA SCARICARE ONLINE SUL SITO

Tutte le istruzioni per realizzare tanti esperimenti e approfondire i principi di fisica e meccanica

www.laboratoriodimeccanica.clementoni.com

LE MACCHINE BELLICHE

L'ARIETE



LA CATAPULTA



IL ROTORE DELL'ELICOTTERO



LE LEVE

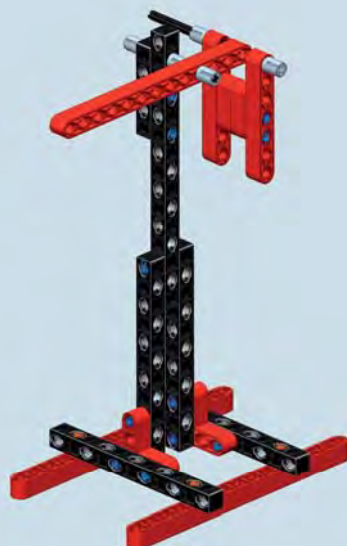

1 L' UTV per il soccorso in spiaggia



Nelle attività di pattugliamento e soccorso in spiaggia, gli UTV (Utility Task Vehicle) vengono ampiamente utilizzati per le loro capacità di muoversi agevolmente in spazi ridotti e terreni accidentati. A differenza di un normale quad, l'UTV permette di caricare a bordo da 2 a 6 persone ed è caratterizzato dal doppio sedile anteriore, per il quale prende anche il nome di "Fianco a Fianco".

Alcuni veicoli più moderni possono montare fino a 6 ruote o addirittura un sistema formato da 4 cingoli.

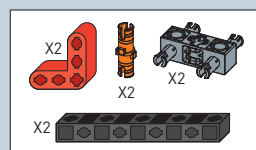
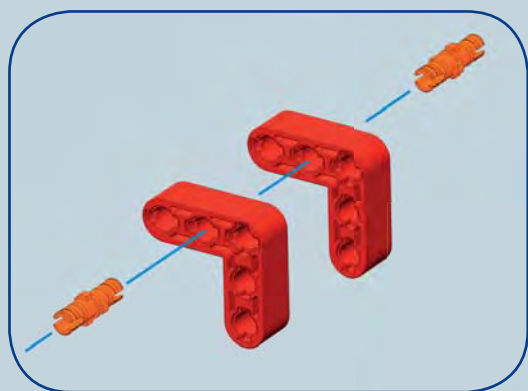

1

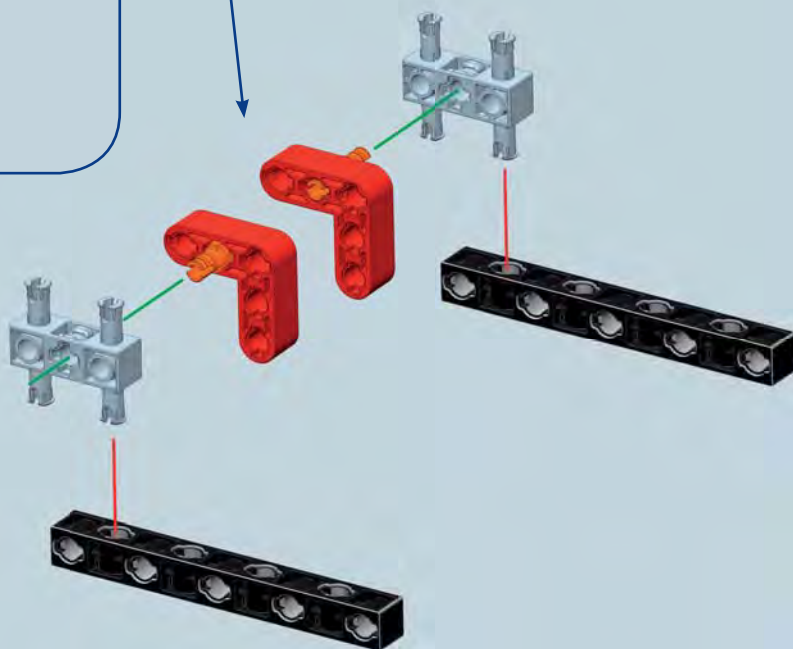

2

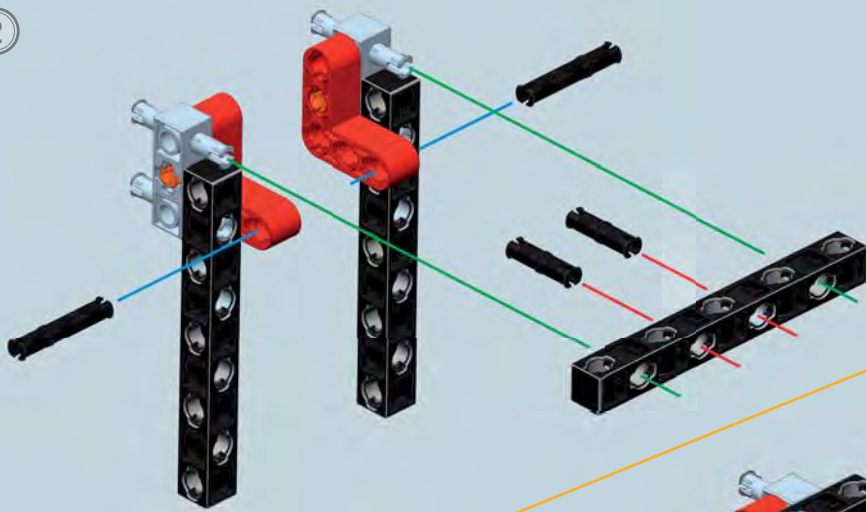

- X2
- X2
- X1

3

- X1
- X2

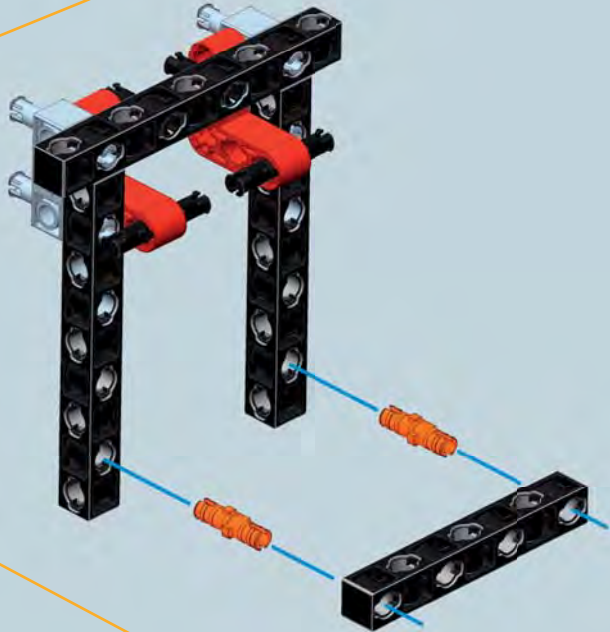

4

- X4
- X2

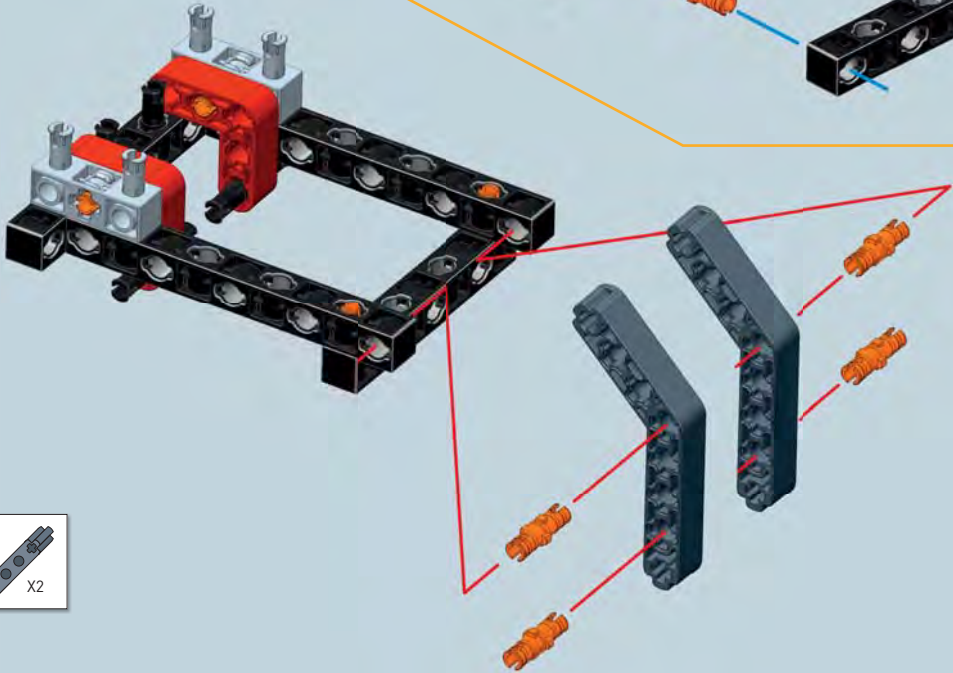

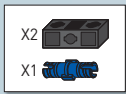

5

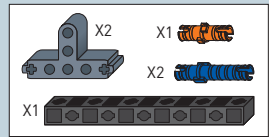
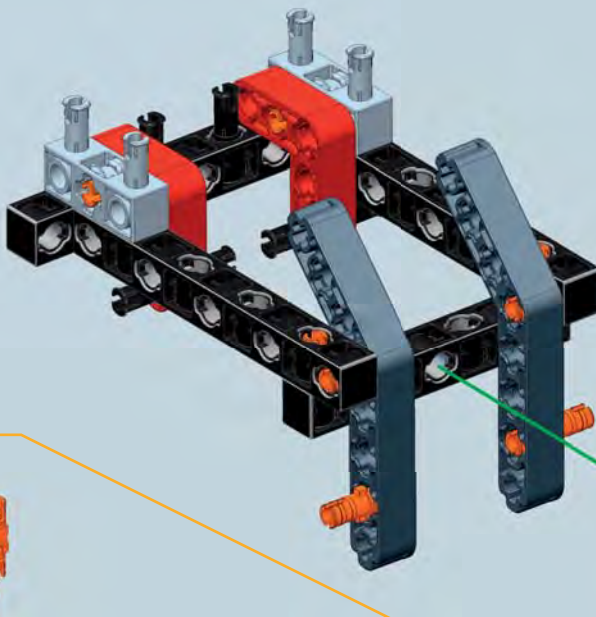

6

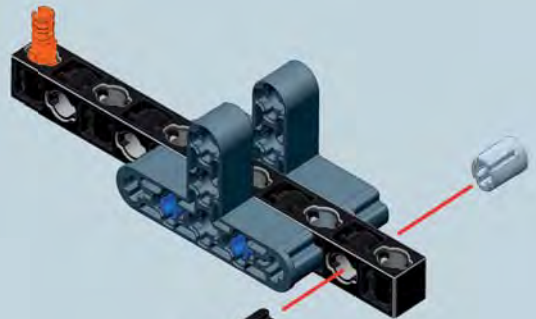
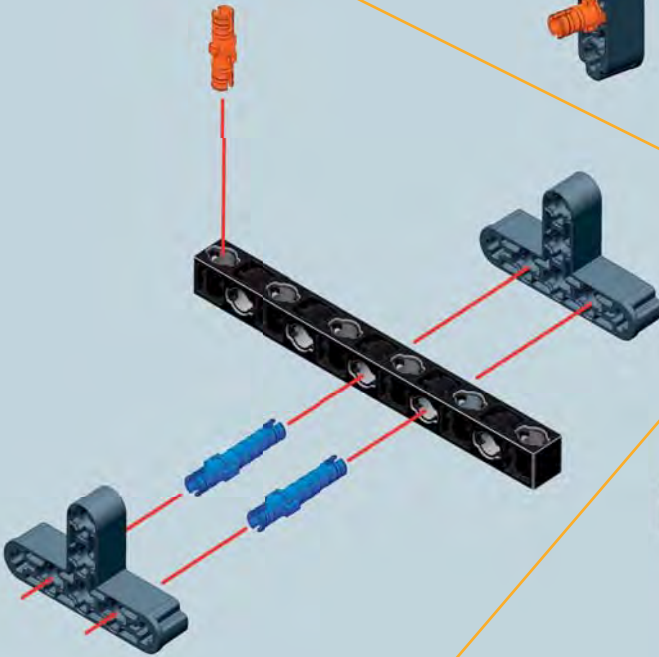





7

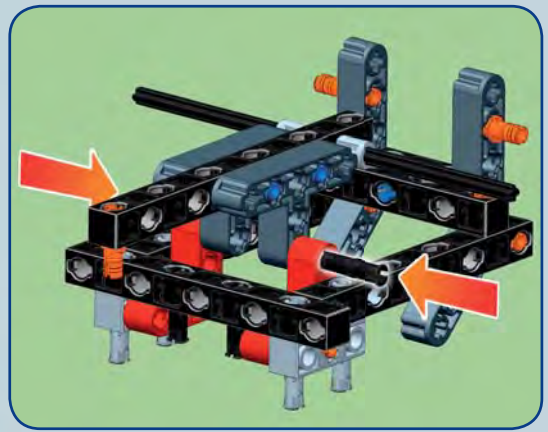
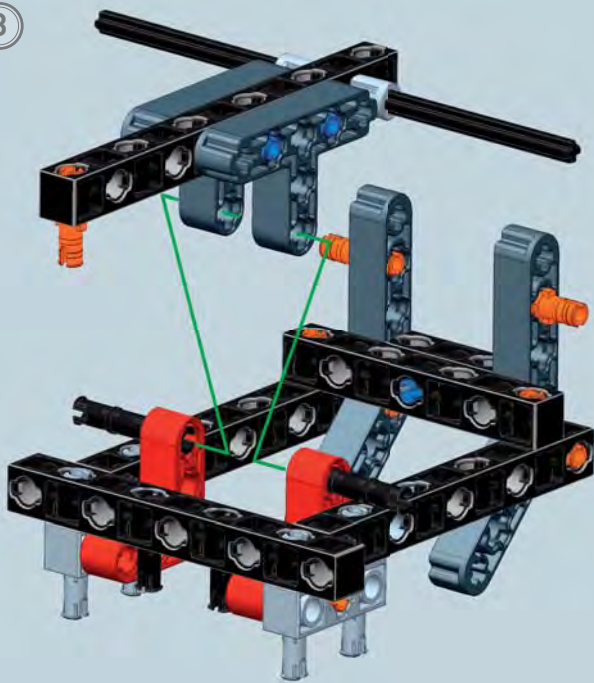

8



9

- X2  X2 
- X2  X2 

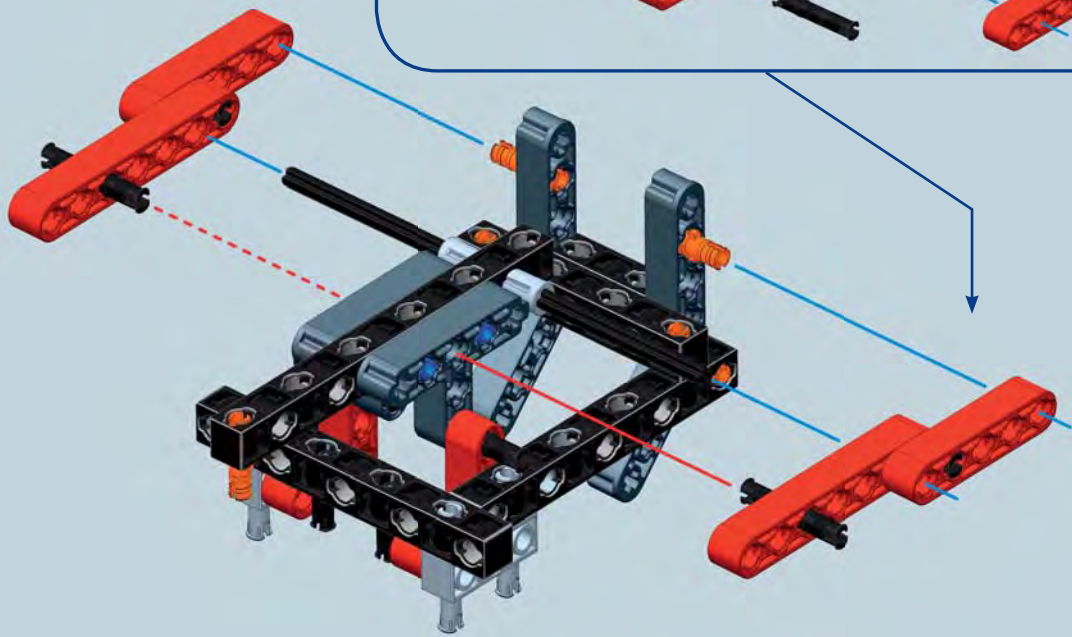
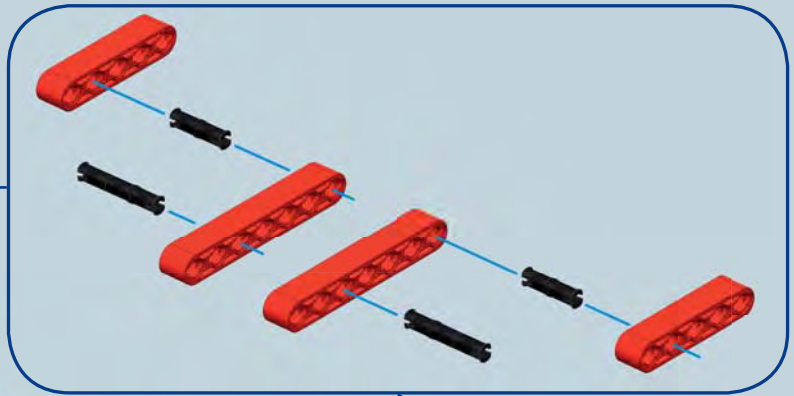

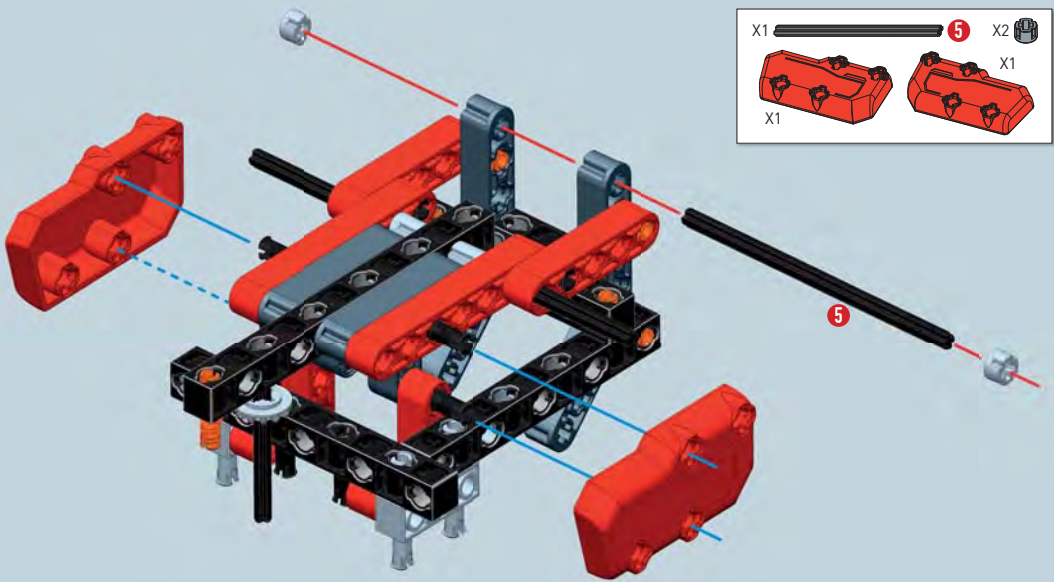

- X1 5 X2
- X1
- X1

10

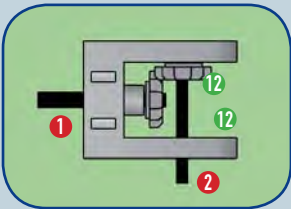

- X1 1 X1 2
- X1
- X1
- X2
- X1
- X1

11

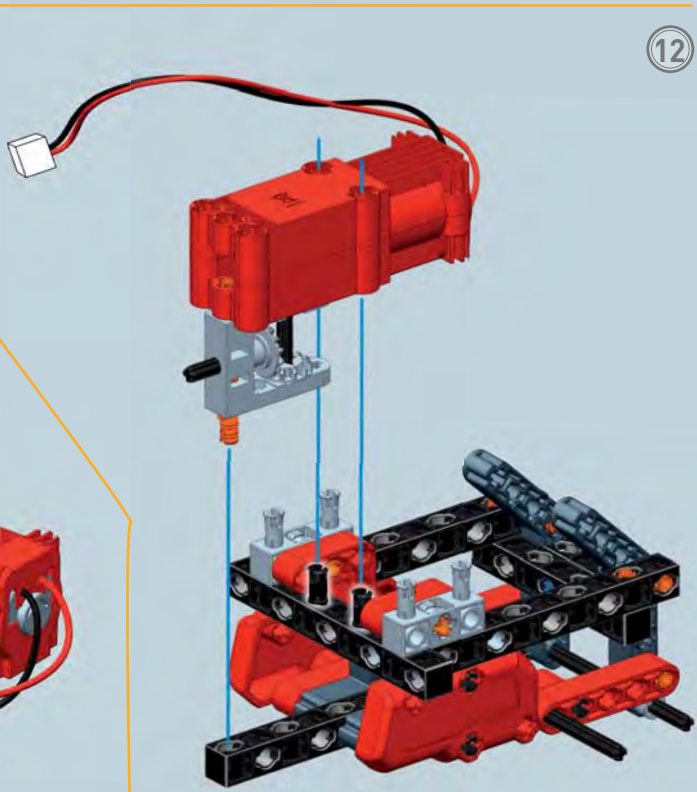
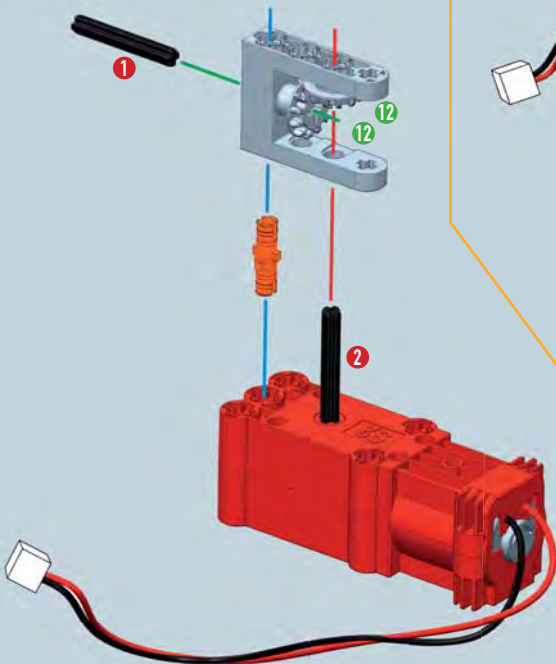

12

- 1:1 1

- 1:1 2

- 1:1 5

13

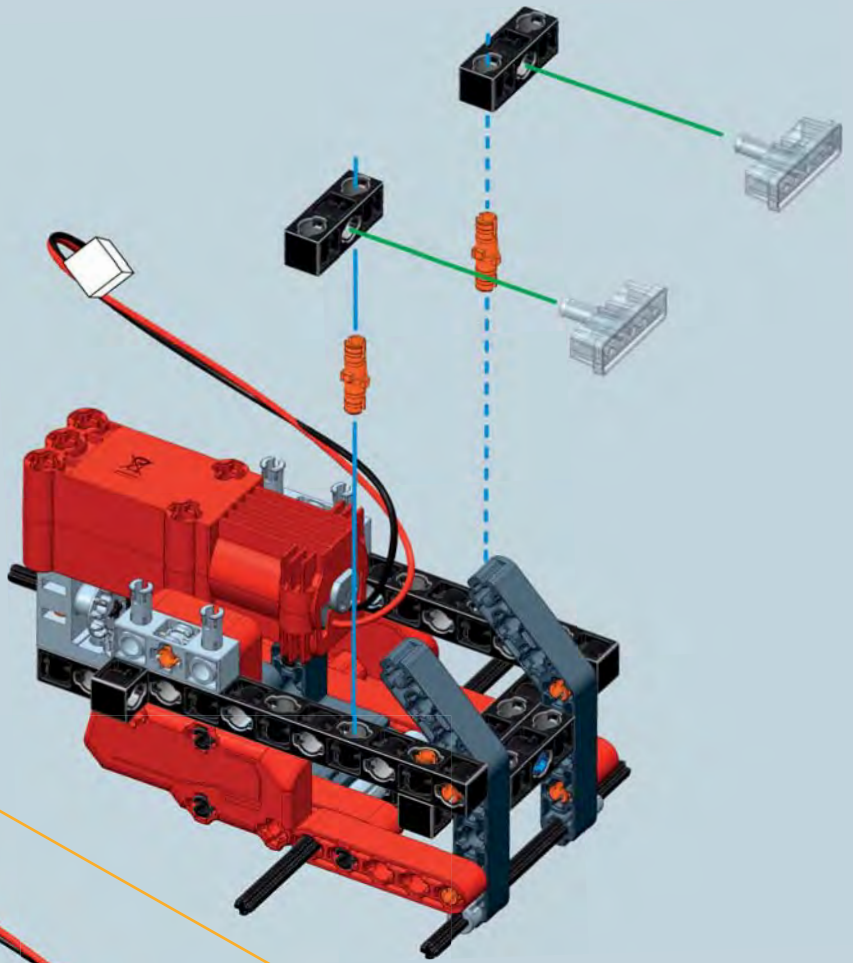
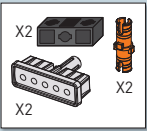

14

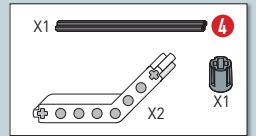
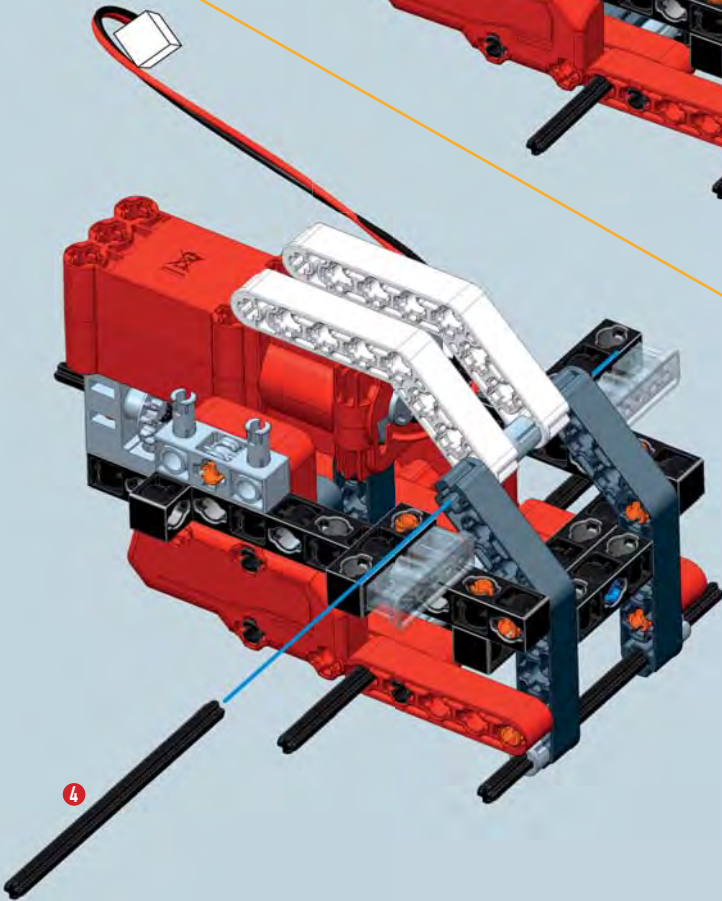

15

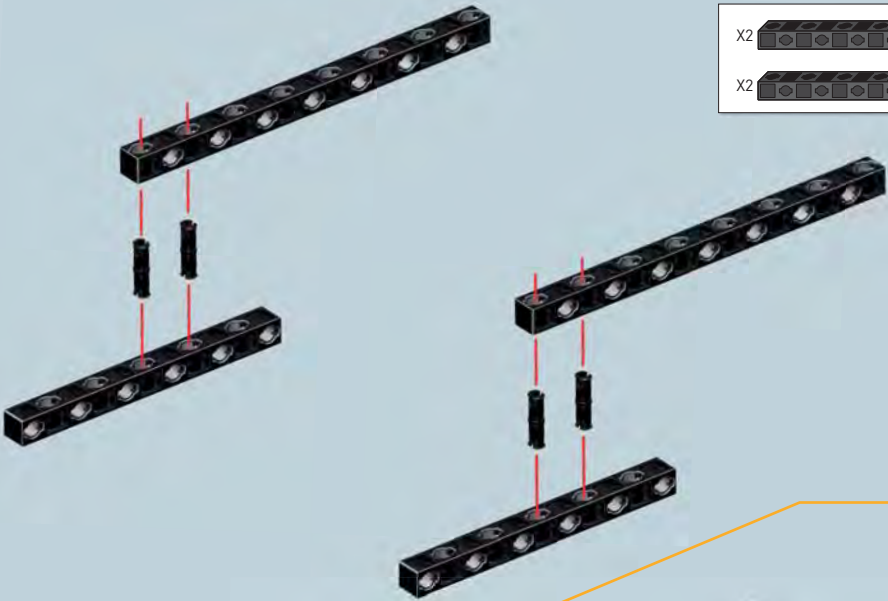

16

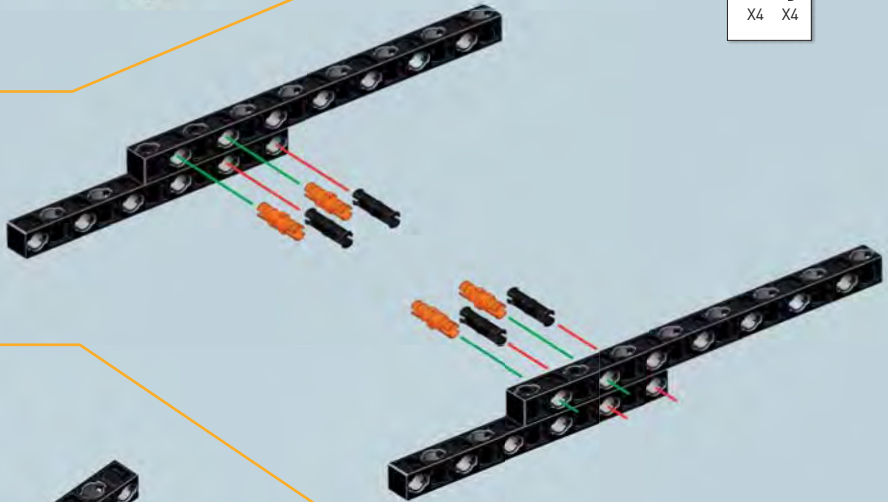

17

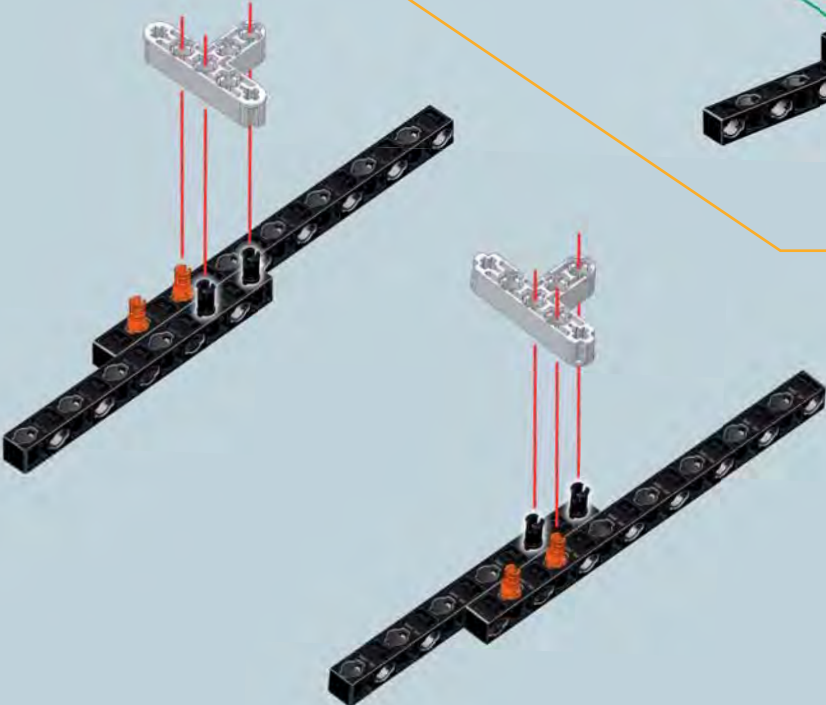
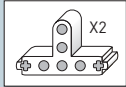

18

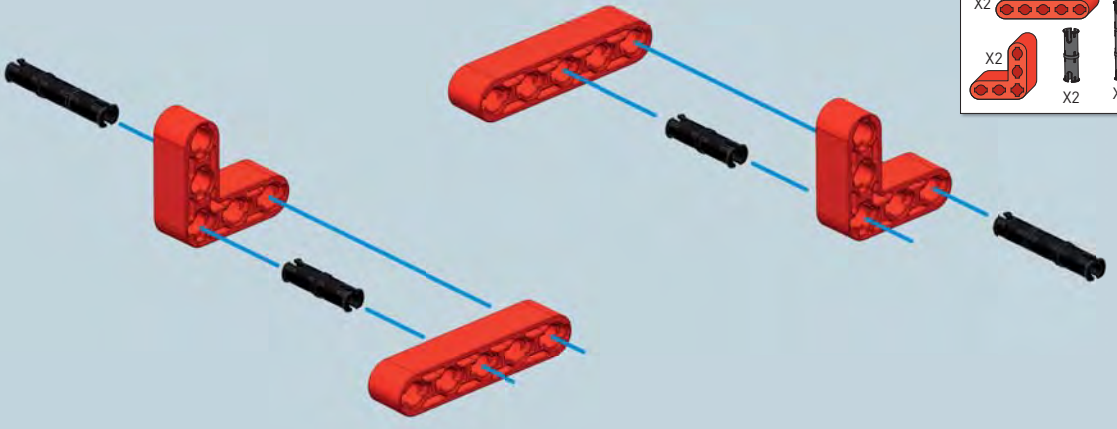

X2		
X2		
		X2

19

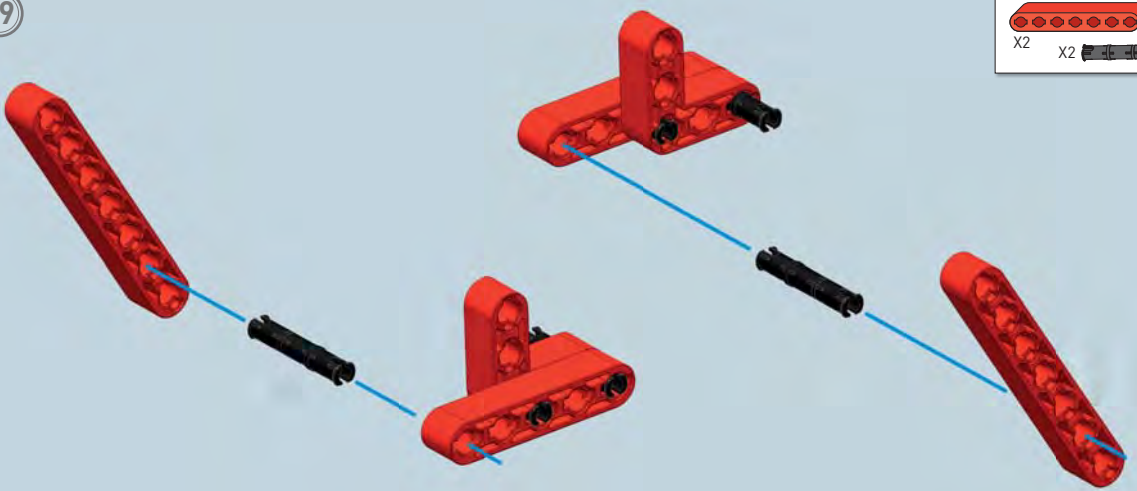

X2		
		X2

20

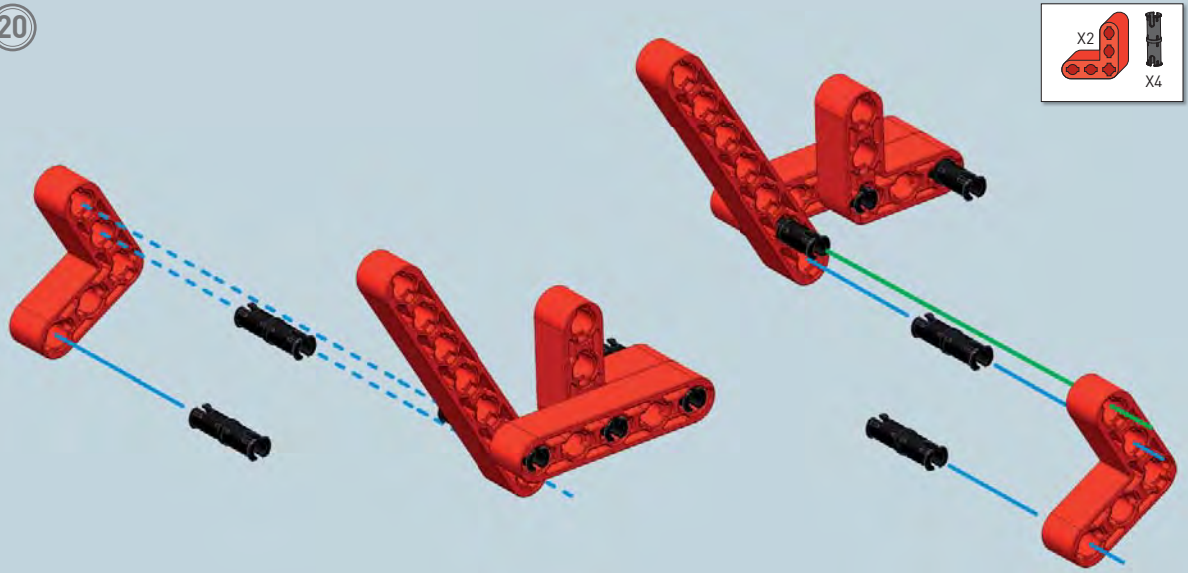

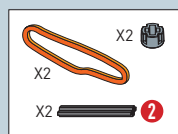
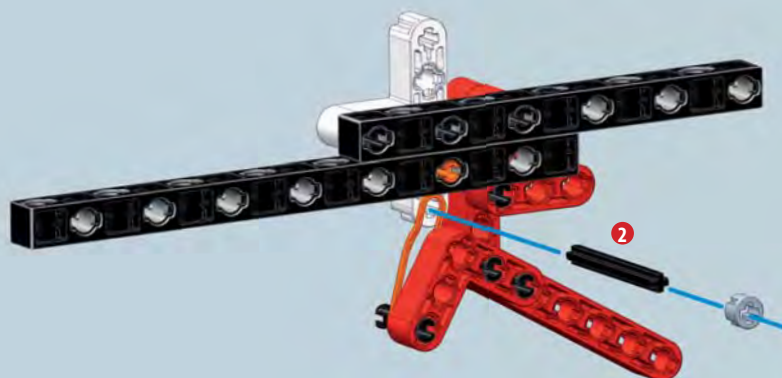
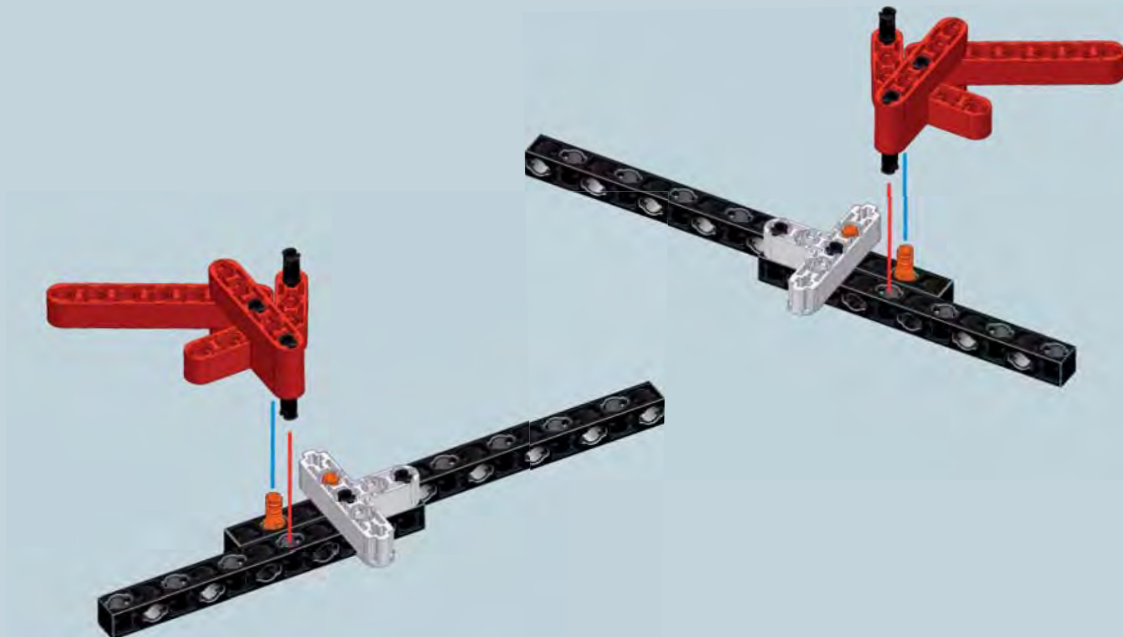

X2		
		X4

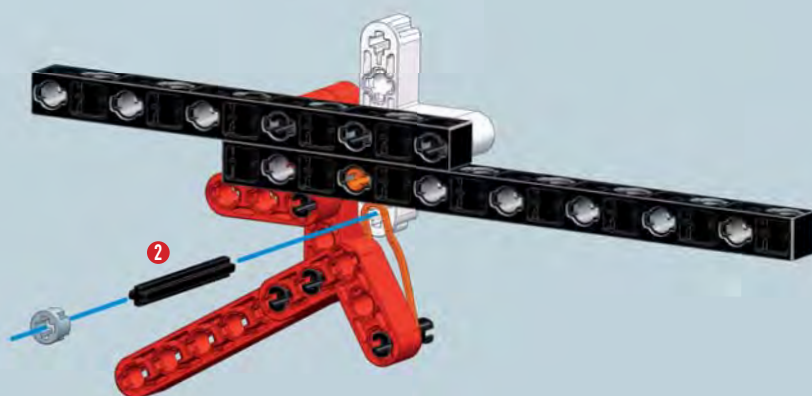

Fissa gli elastici ai chiodini neri corti e poi bloccali con l'astina 2 all'altezza del foro indicato nell'immagine.





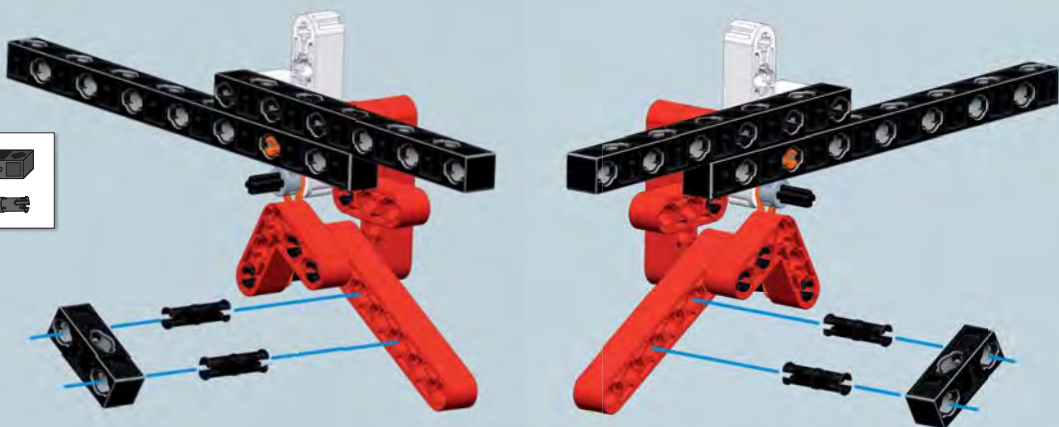

23

- X2 
- X4 





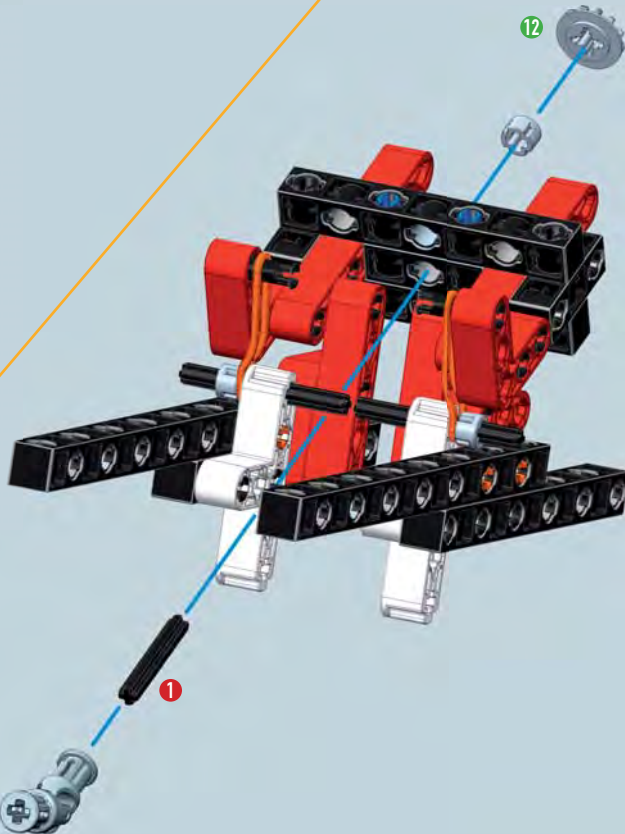
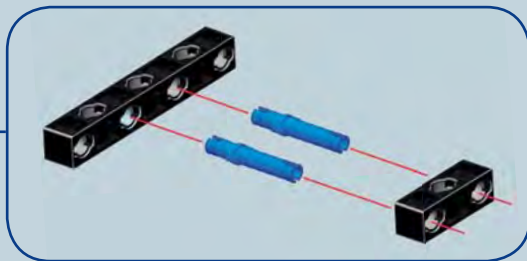
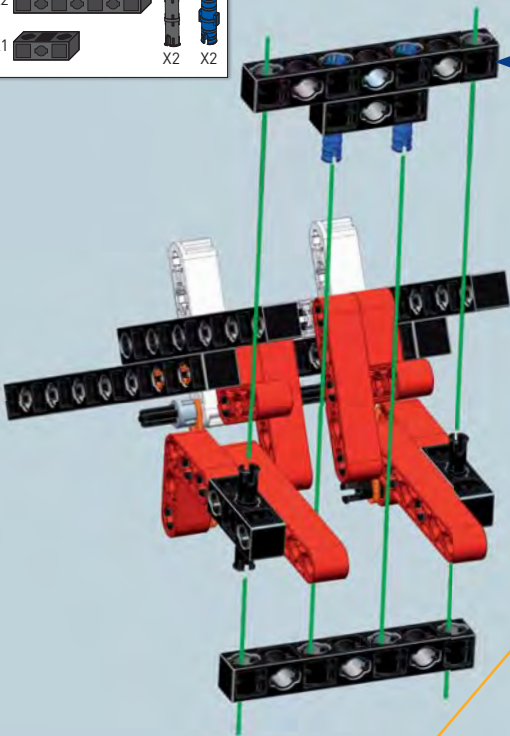

24





- X2 
- X1 
- X2 
- X2 



25

- X1 
- X1 
- X1  1
- X1  12

Per assemblare il giunto cardanico
seguì le indicazioni stampate sul
foglio delle avvertenze

- X1  6
- X1  12
- X3 
- X2 

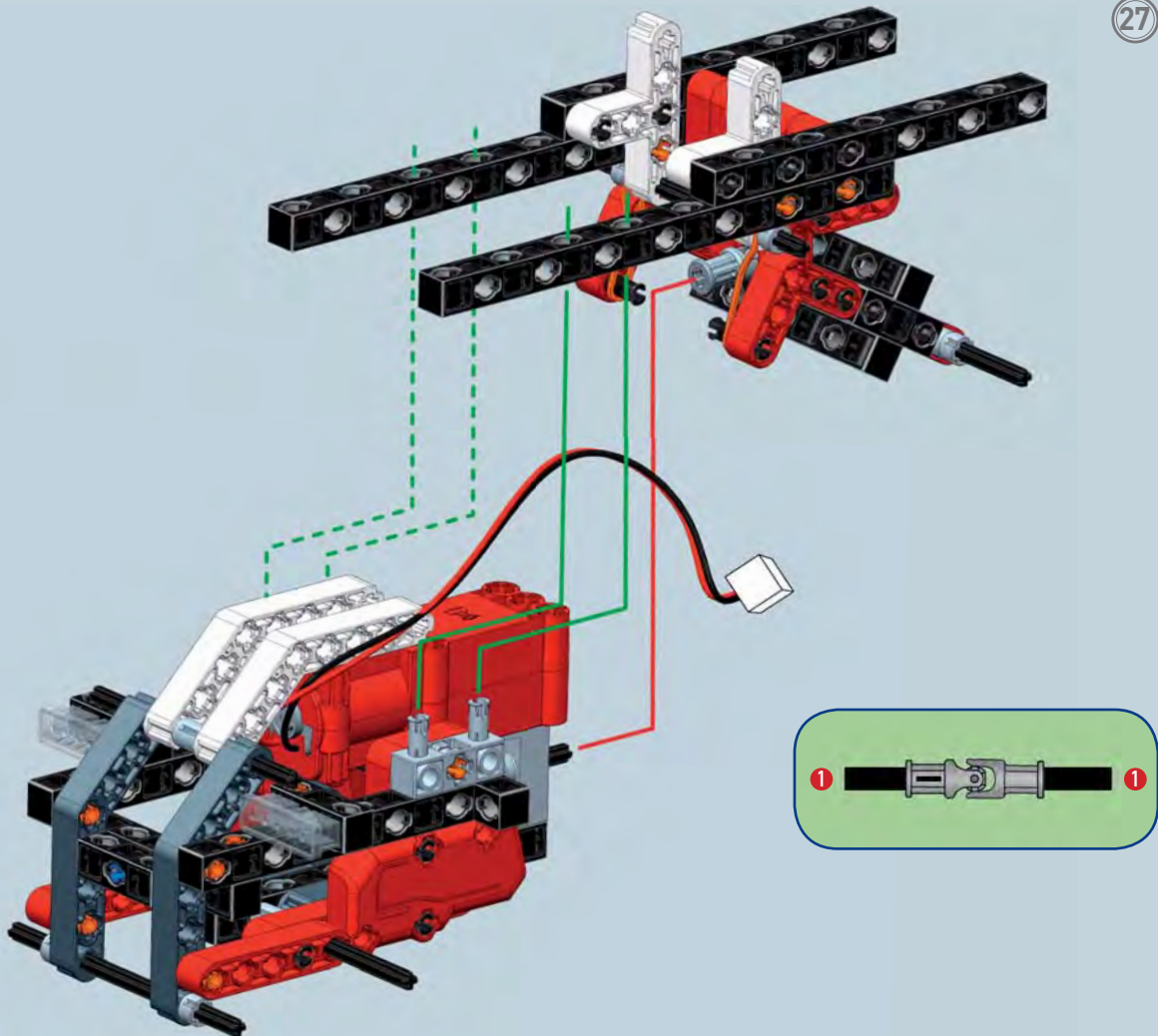
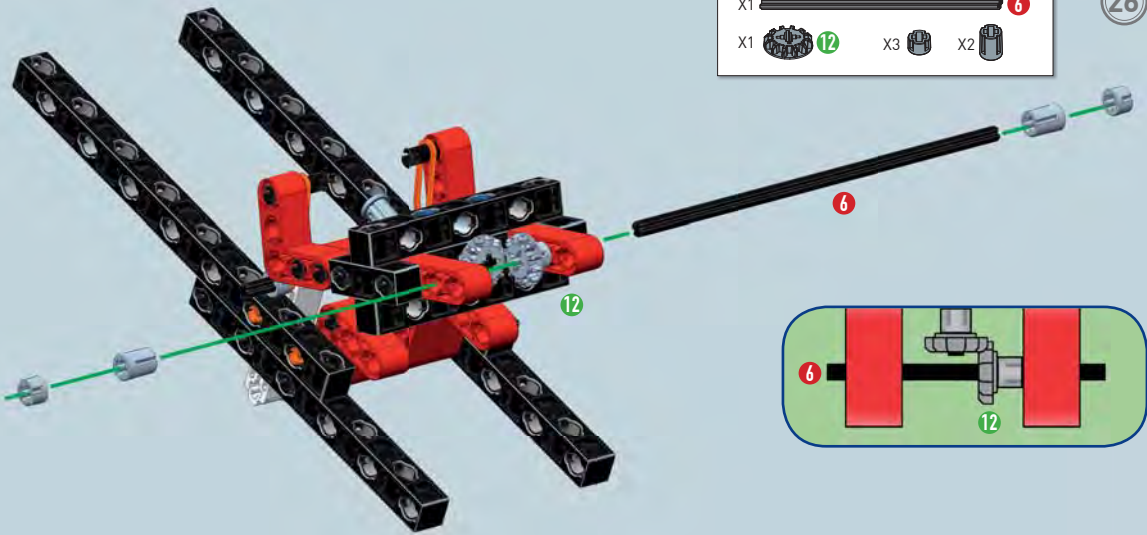

28

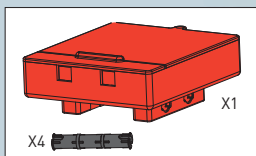
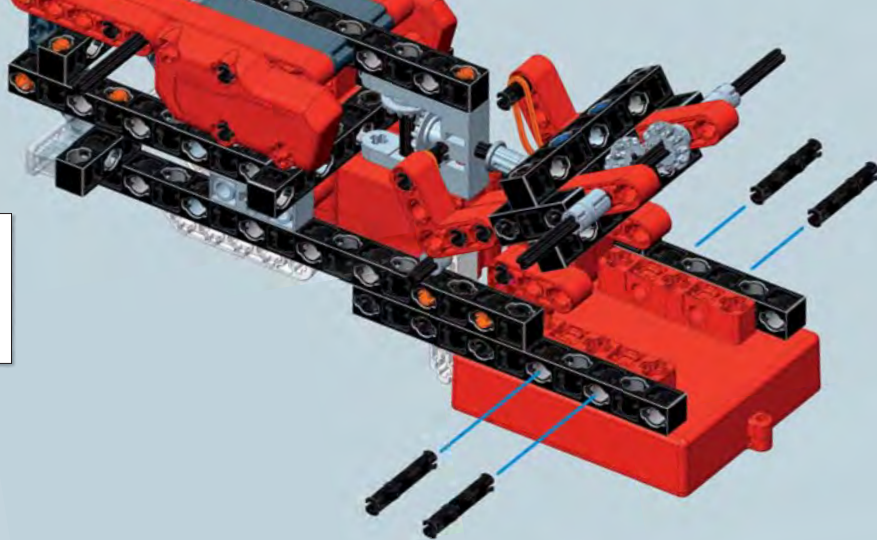

29

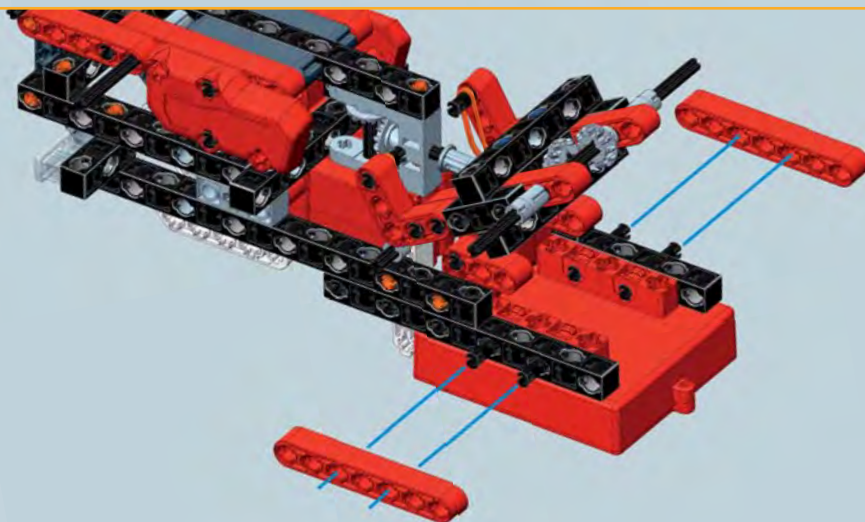

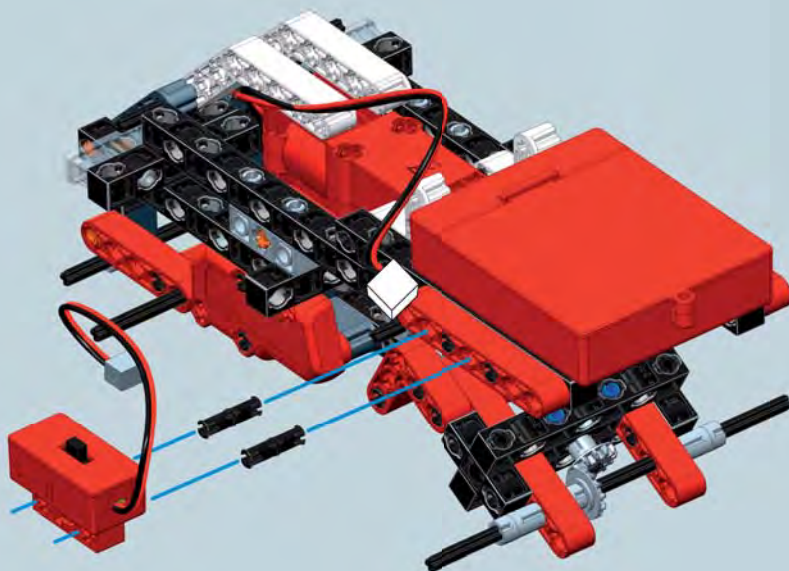
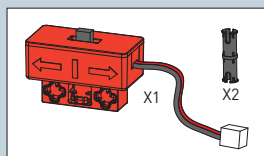

30





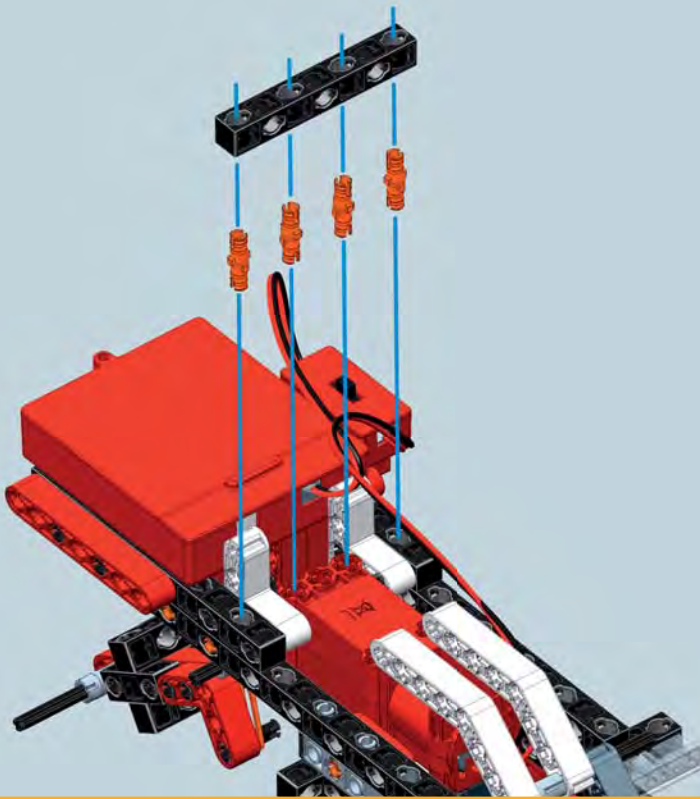

**Connetti il cavo del motore
allo switch e il cavo dello
switch al vano batterie.**

31

- X1 
- X4 



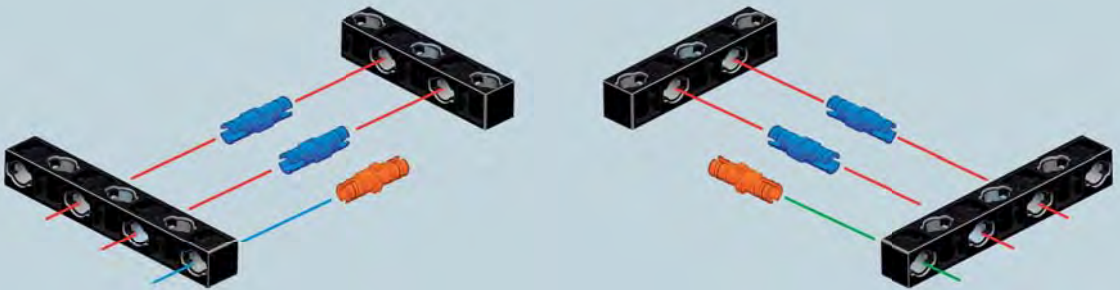

32

- X2 
- X2 
- X4 
- X2 



33

- X2 
- X2 

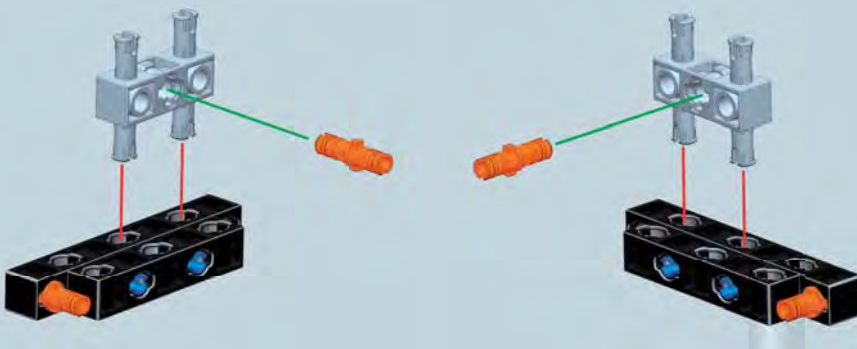

34

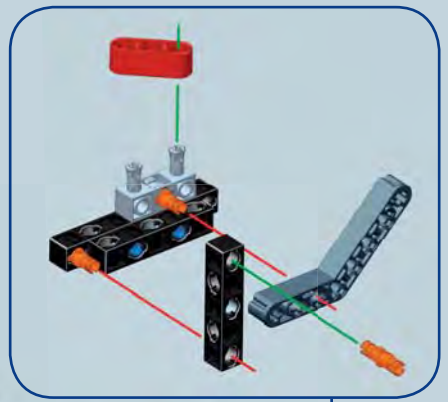
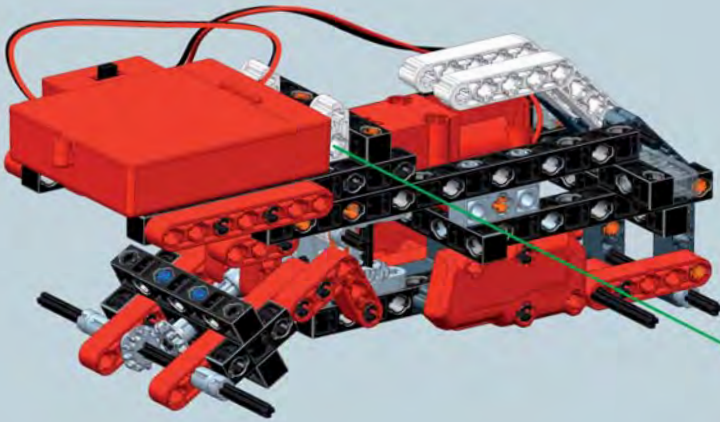
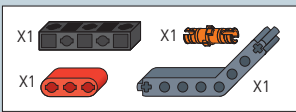

35

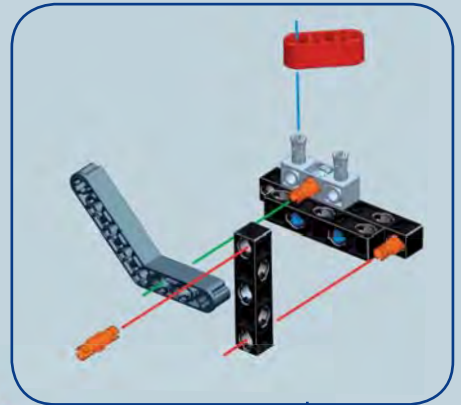
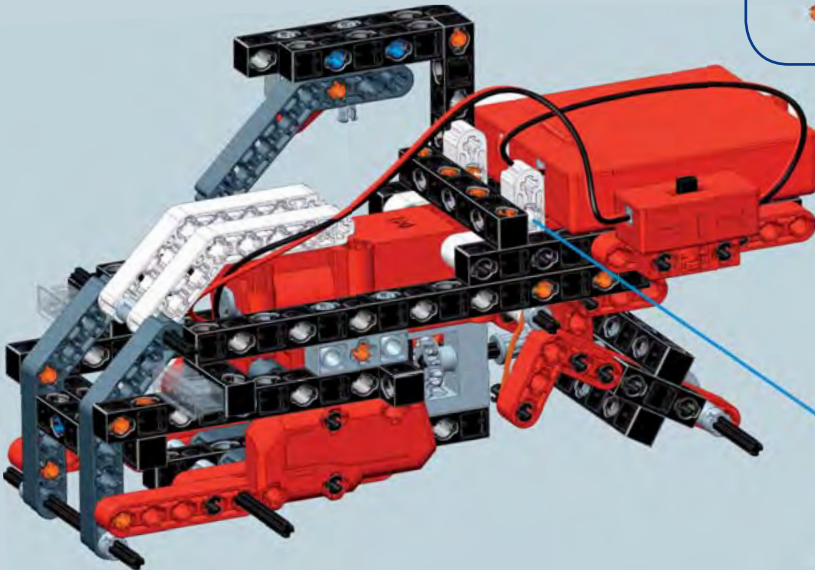
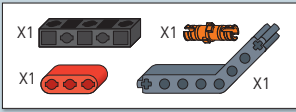

X1  5 X3  X2 

36

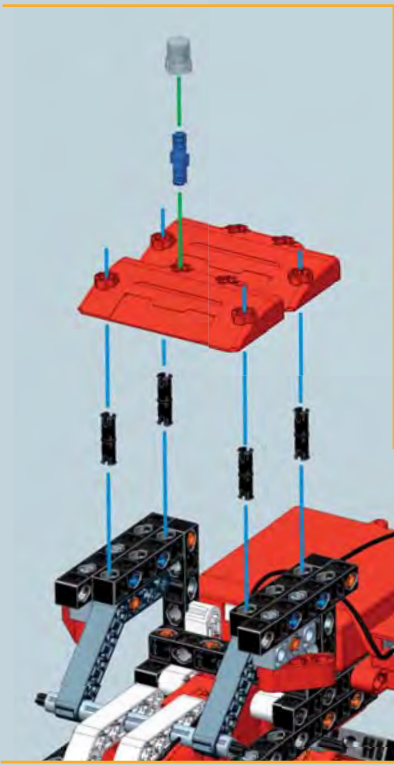
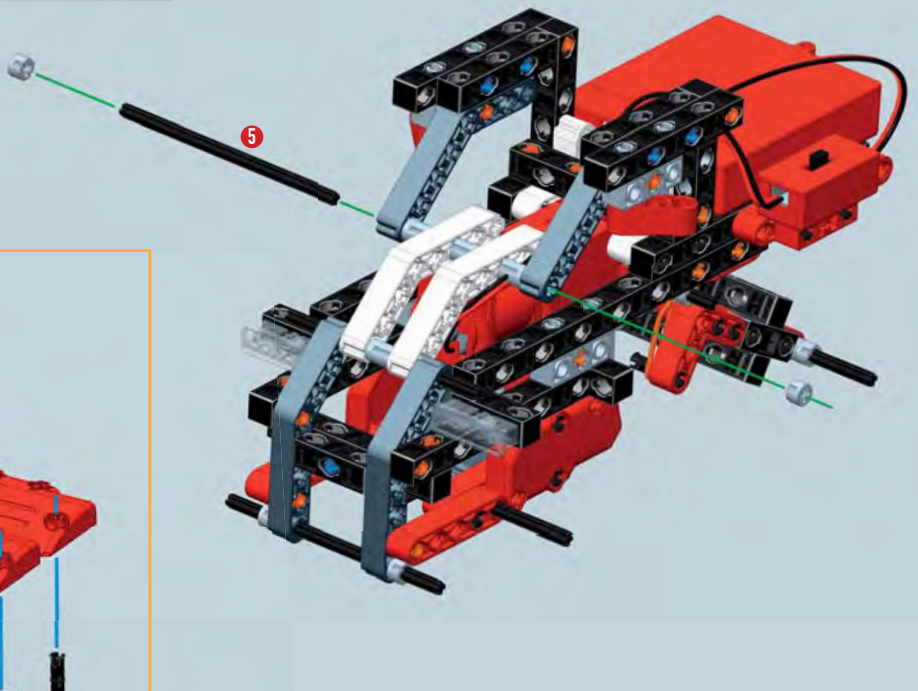

37

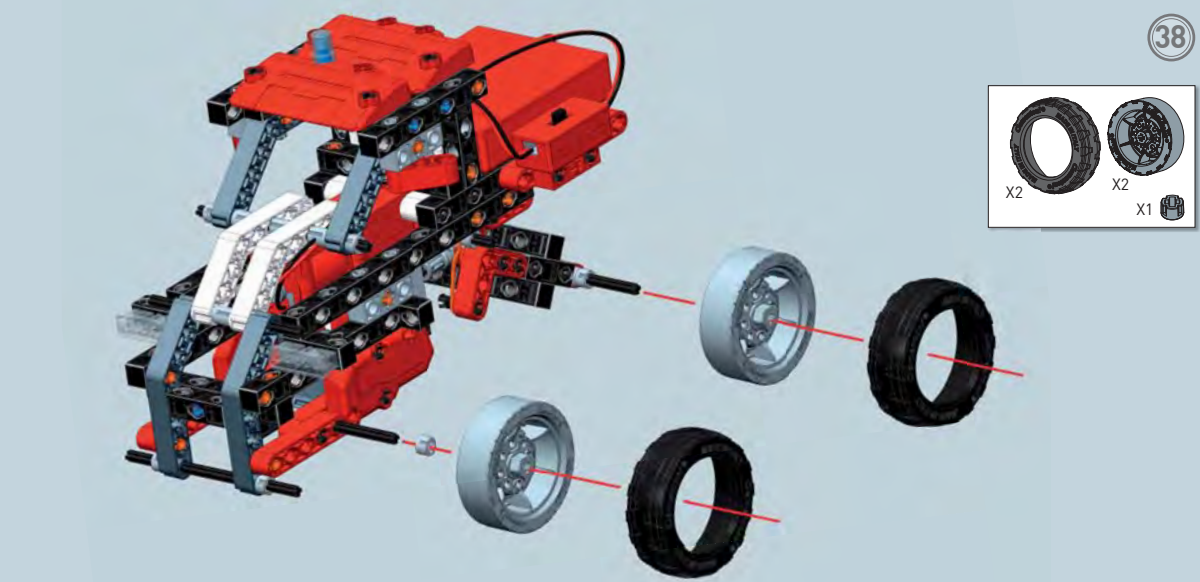
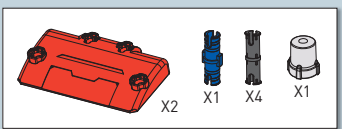

38

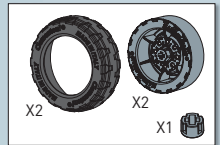

1:1  5

39

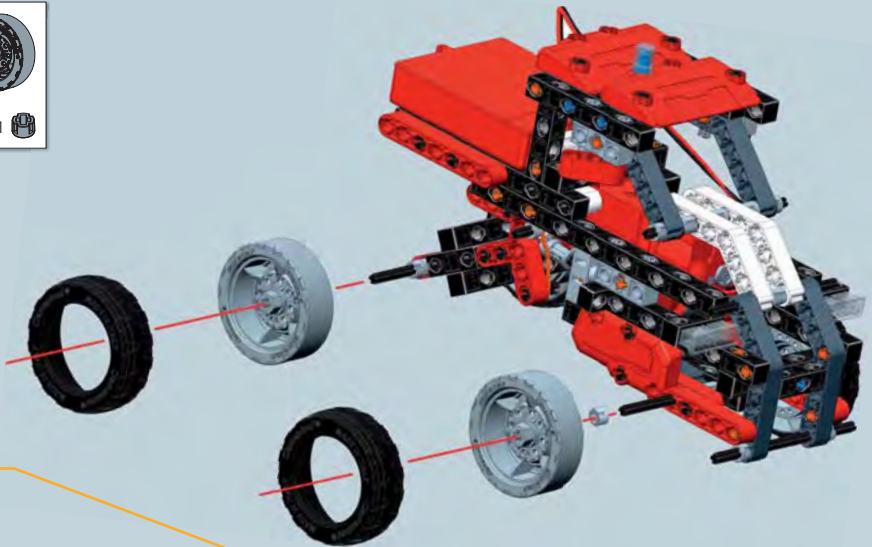
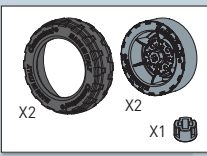

40

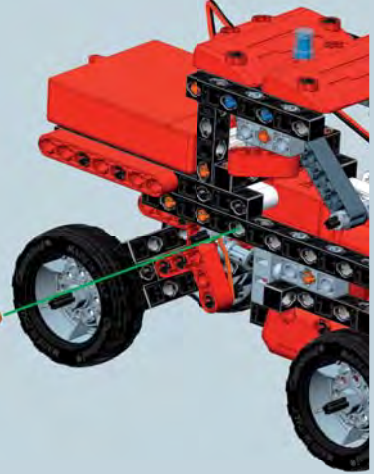
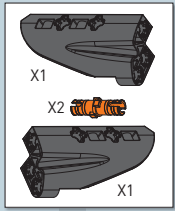

41

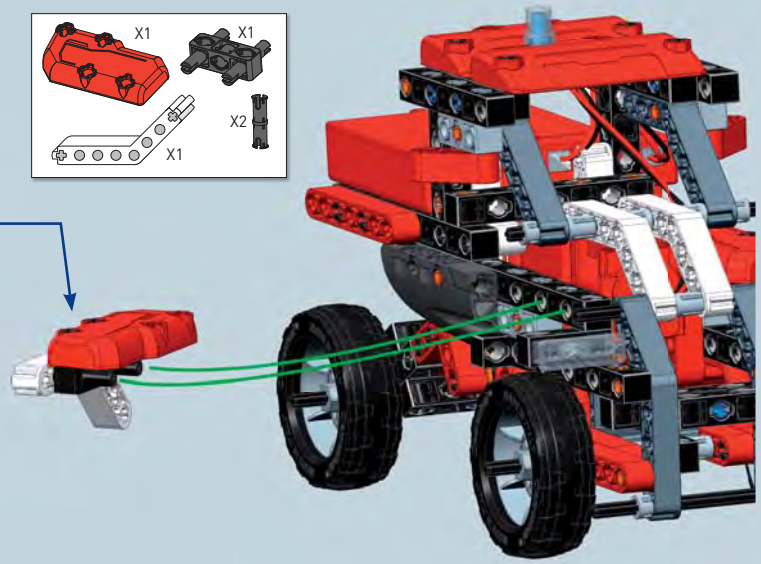
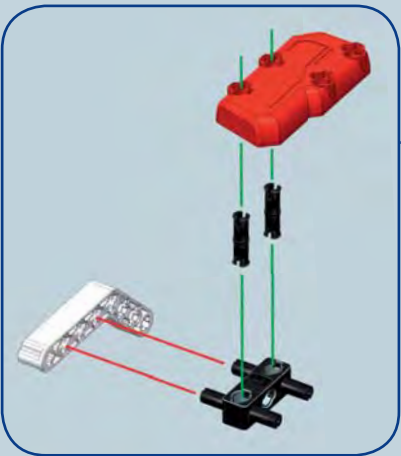
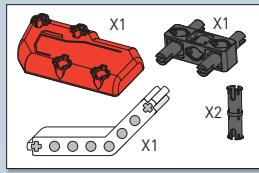

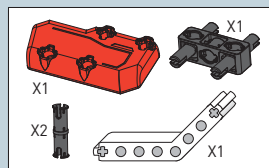
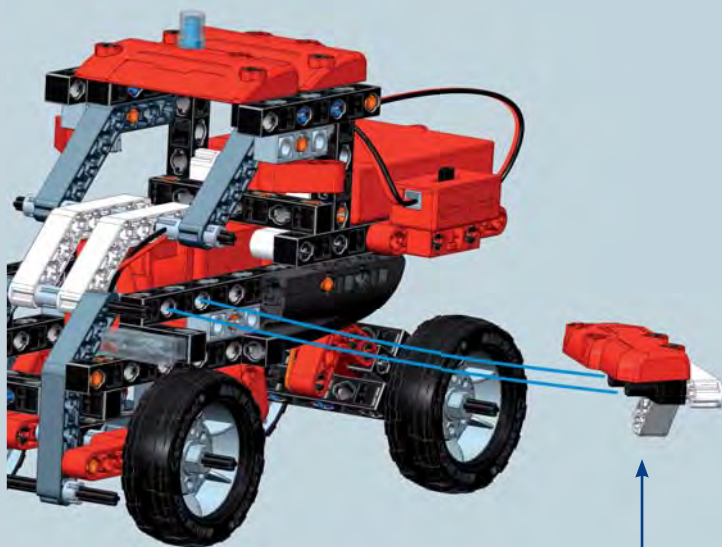

42

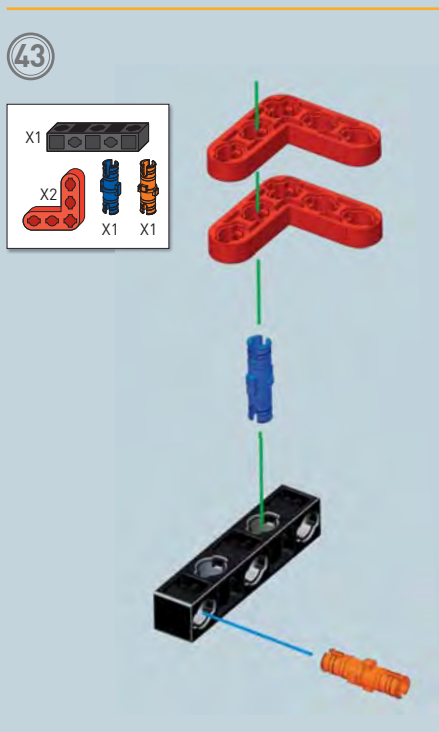
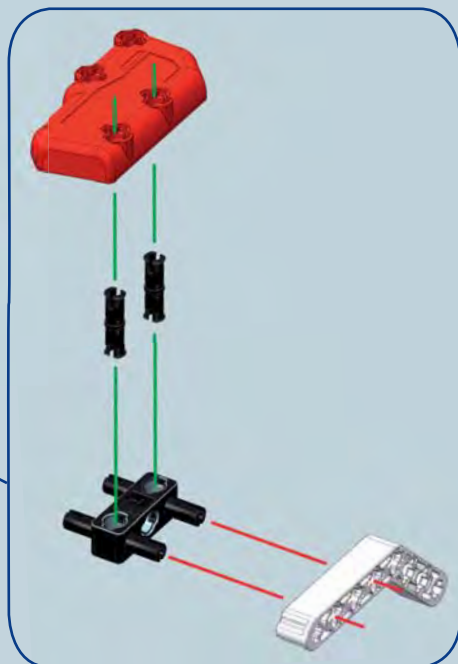

43

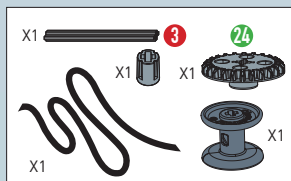
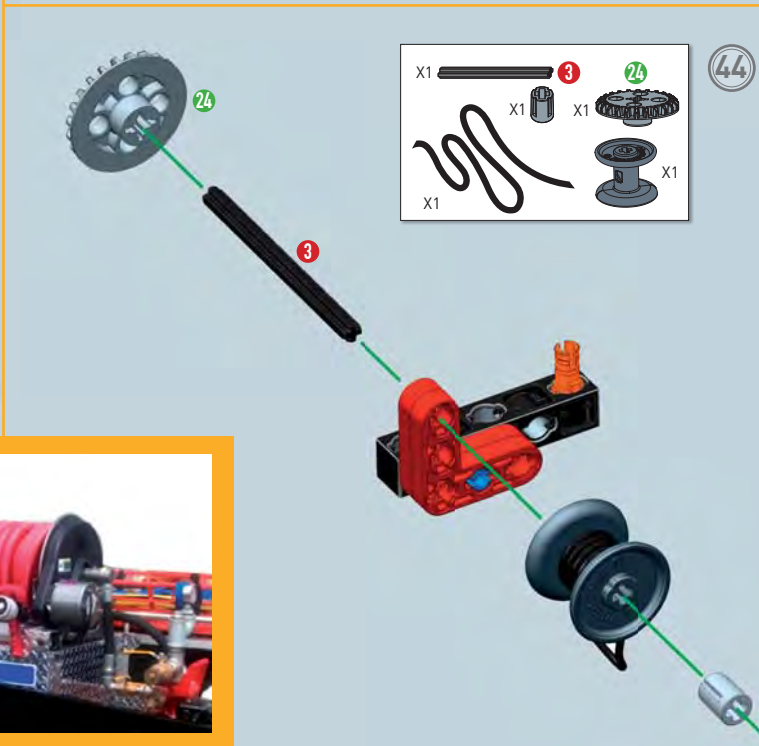
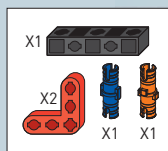

44

Notizie tecniche e curiosità

Alcuni veicoli sono dotati di strumenti antincendio: serbatoi d'acqua montati sul retro del mezzo con appositi tubi per indirizzare il getto.



45

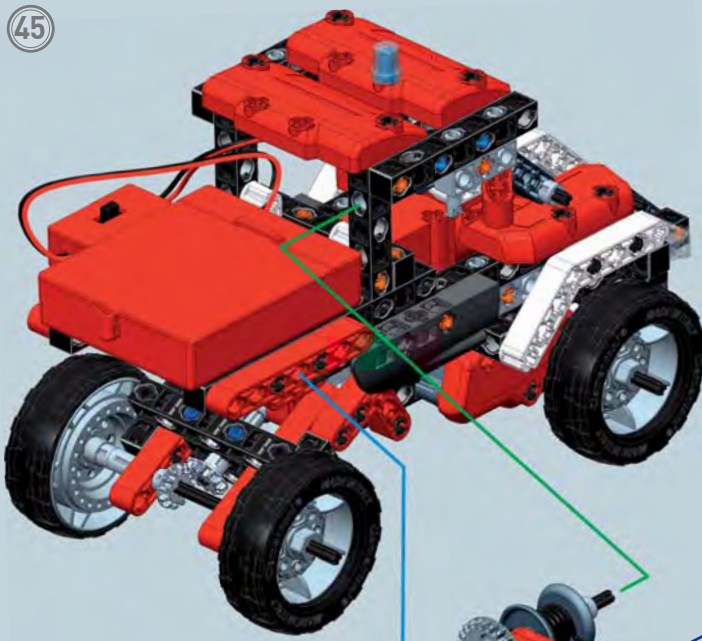

46

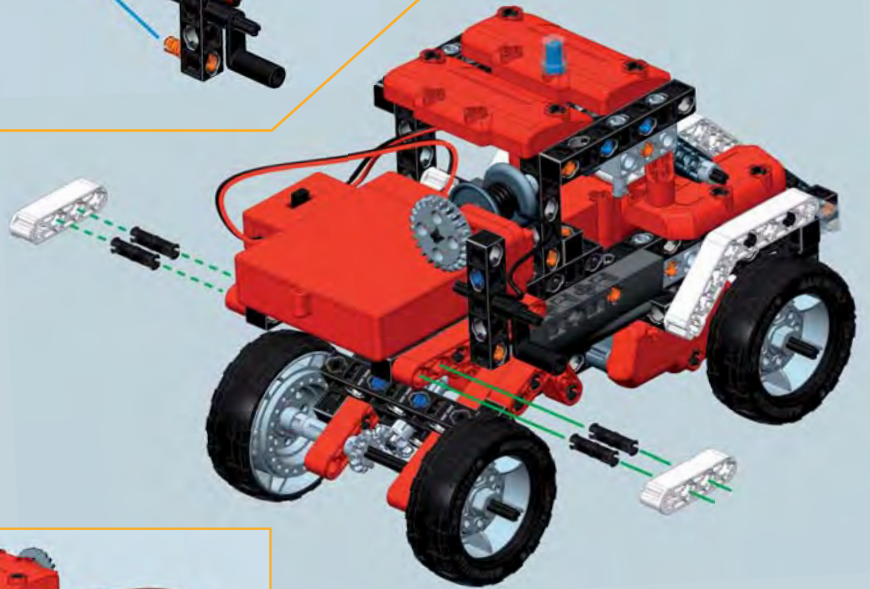
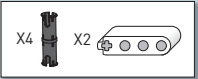

Usa lo switch per attivare la rotazione delle ruote posteriori.





L'hovercraft è un veicolo in grado di scivolare sull'acqua grazie ad un "cuscino d'aria" che si viene a creare sotto le minigonne flessibili. Non ha eliche immerse in acqua, ma montate a bordo per creare la spinta e aiutare il veicolo nelle virate rapide.

L'impiego degli hovercraft come mezzi di salvataggio è ampiamente adottato in tutto il mondo da Guardie Costiere, Vigili del fuoco, Squadre di Salvataggio e Pronto Soccorso. Le sue caratteristiche tecniche lo rendono veloce e manovrabile allo stesso tempo, oltre a permettergli di raggiungere superfici non accessibili alle normali imbarcazioni.

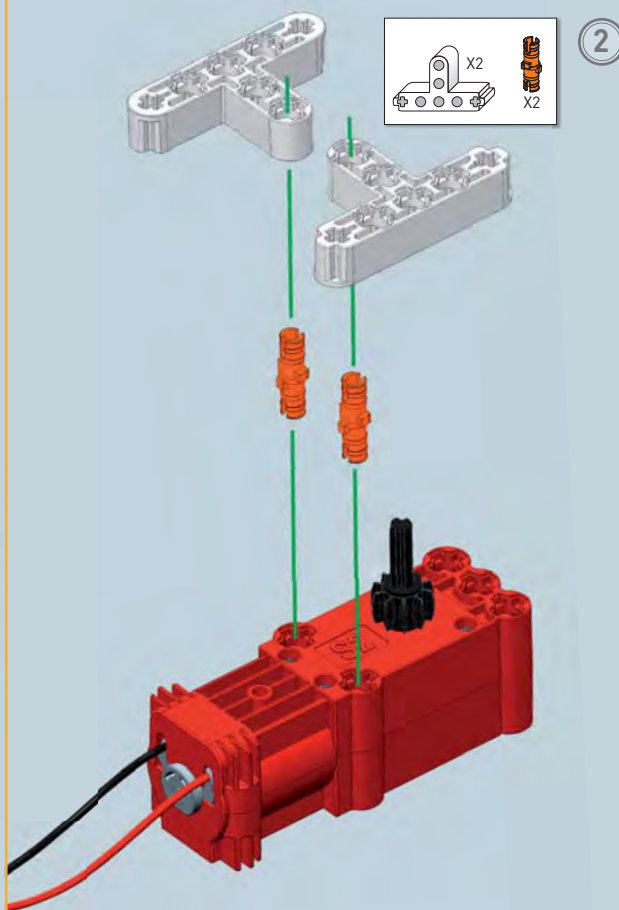
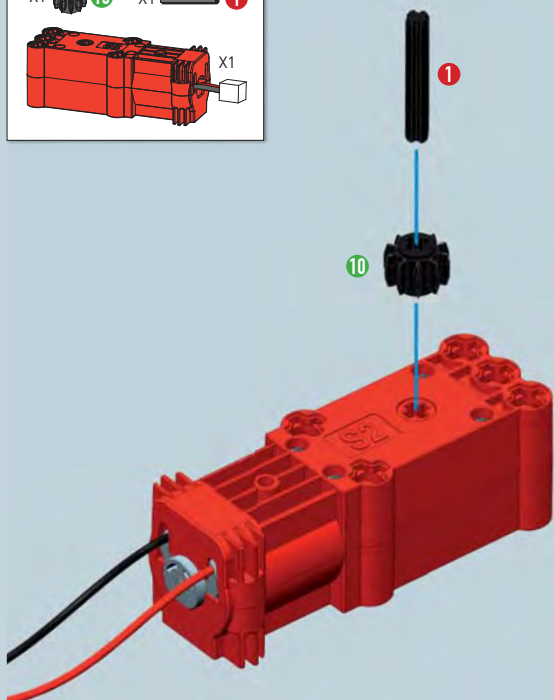
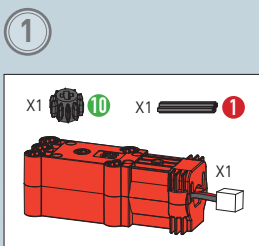

3

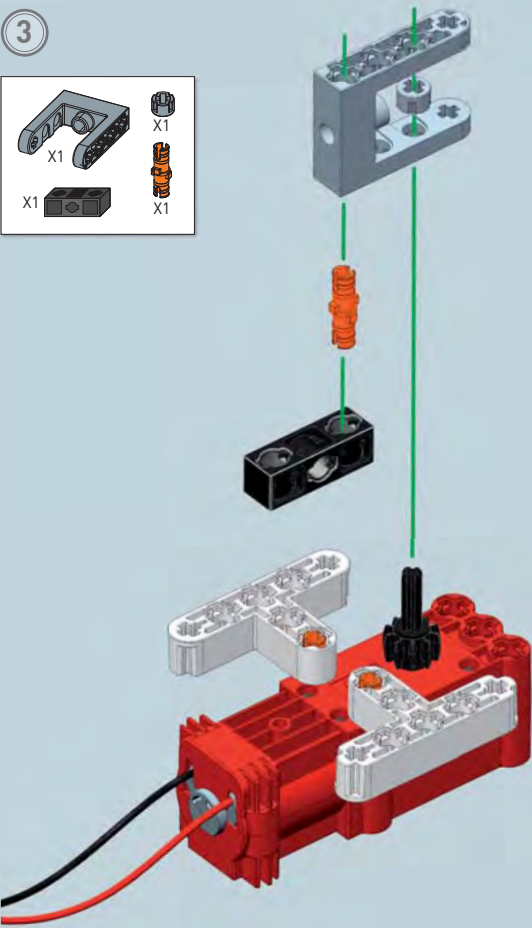
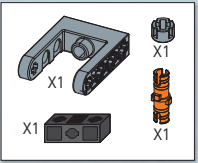

4

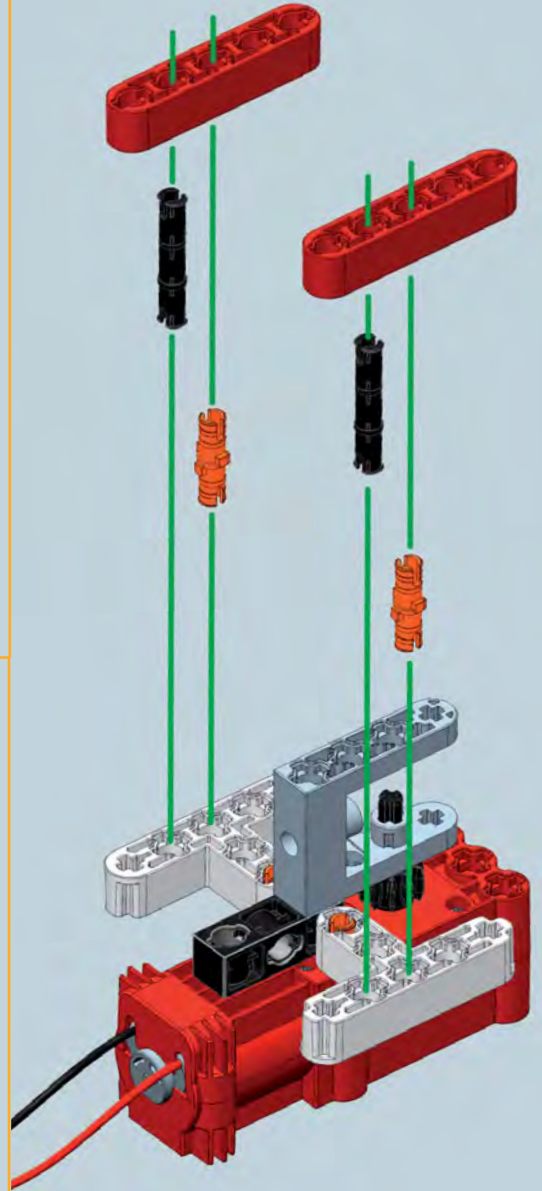
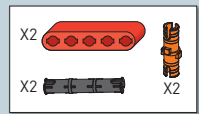

5

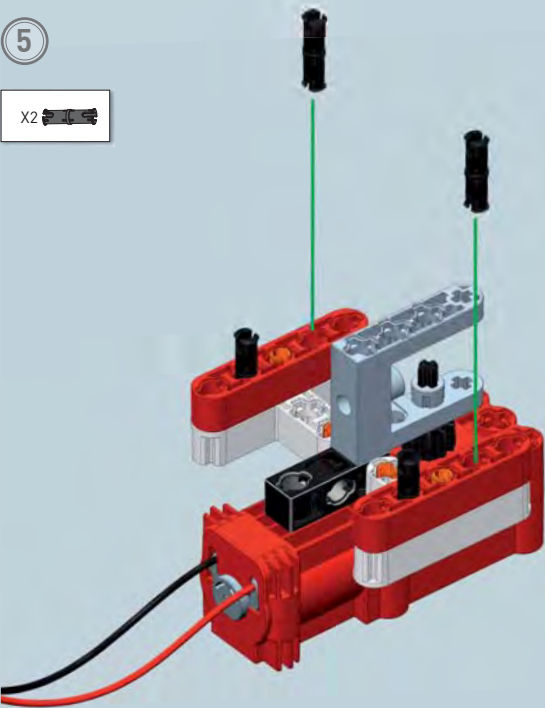
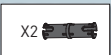

Connetti il cavo dello switch al vano batterie

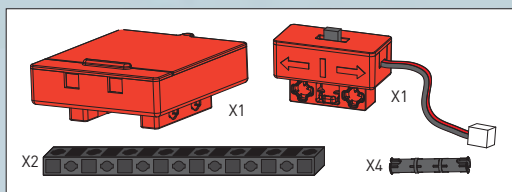
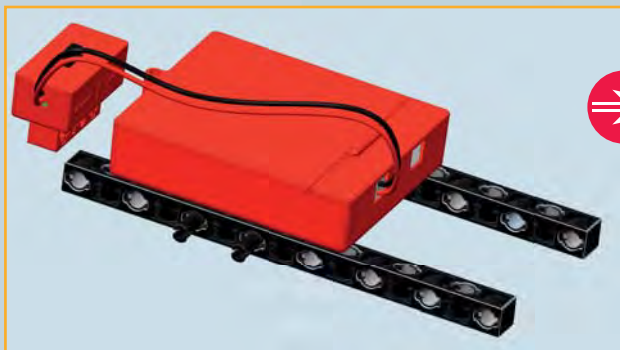
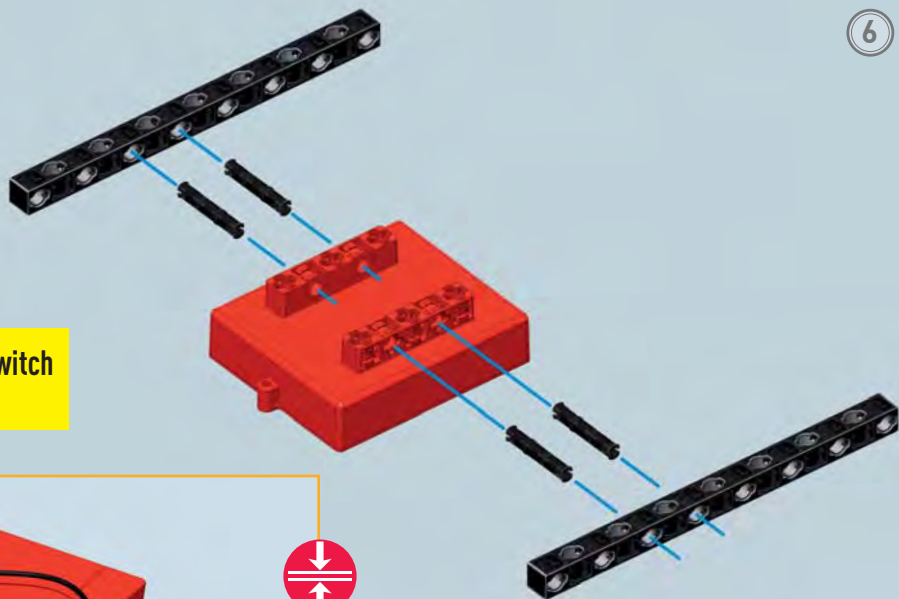

Connetti il cavo del motore allo switch

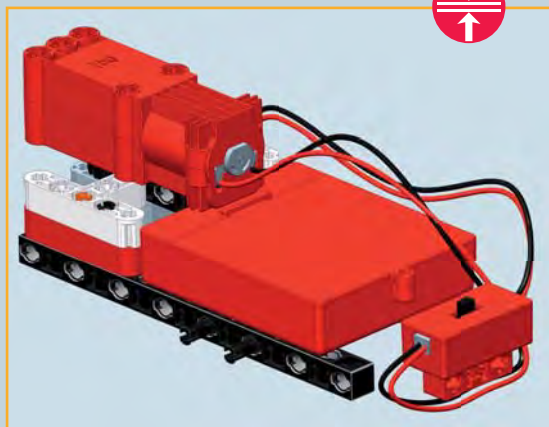
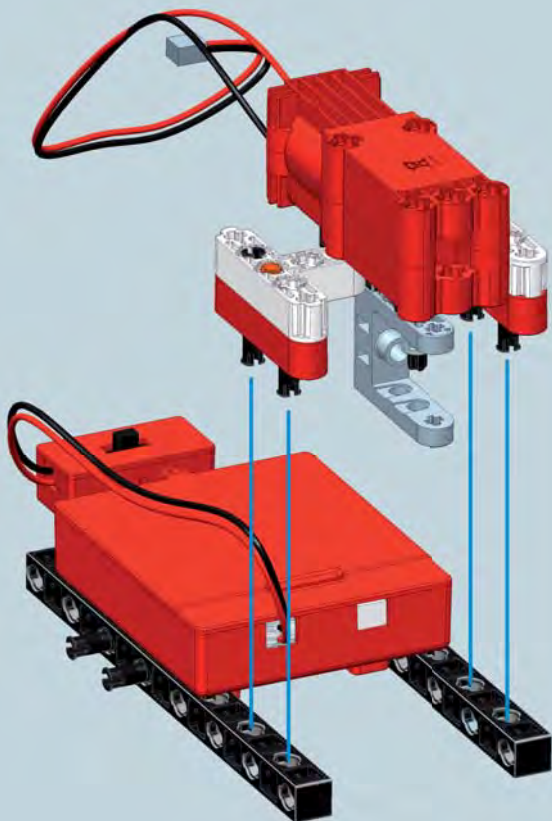

8

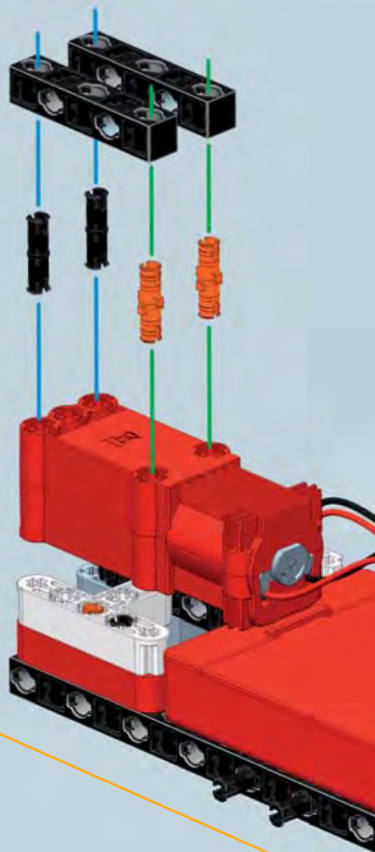

- X2
- X2
- X2

9

- X1
- X1
- X2
- X1

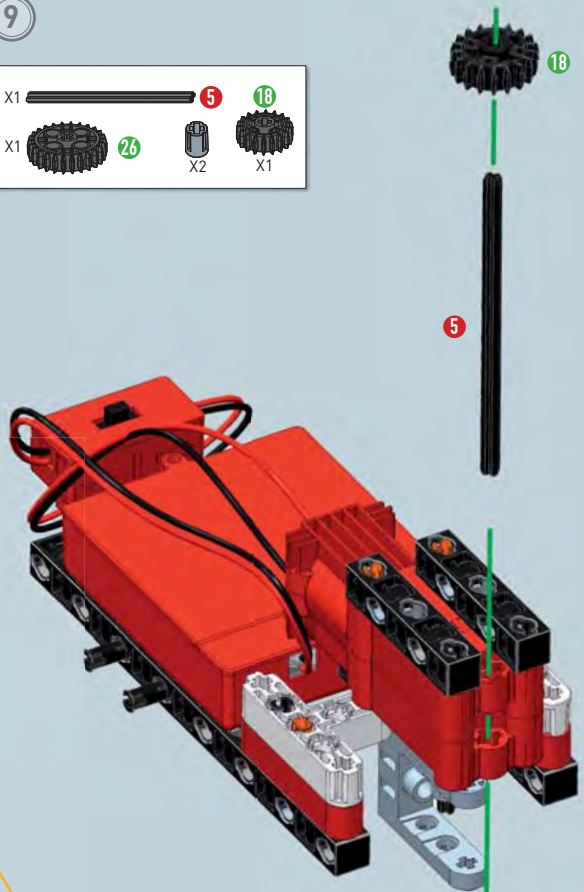

10

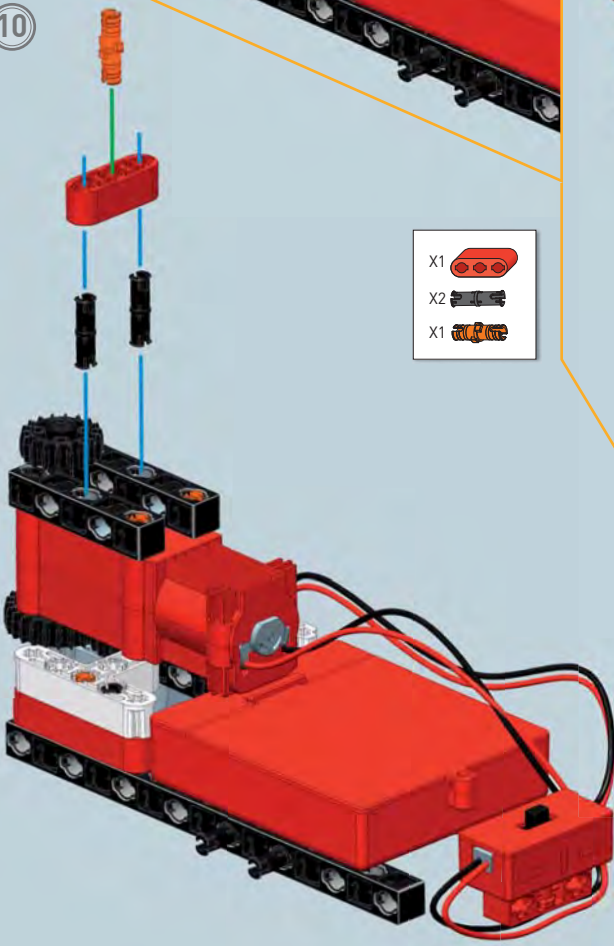

- X1
- X2
- X1



11

X2			X4
X2			



12

X2		4		18
X1		3		X1
X1				X3

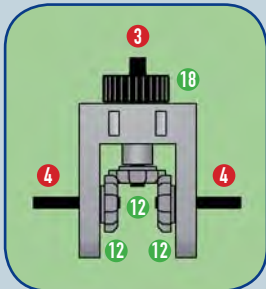
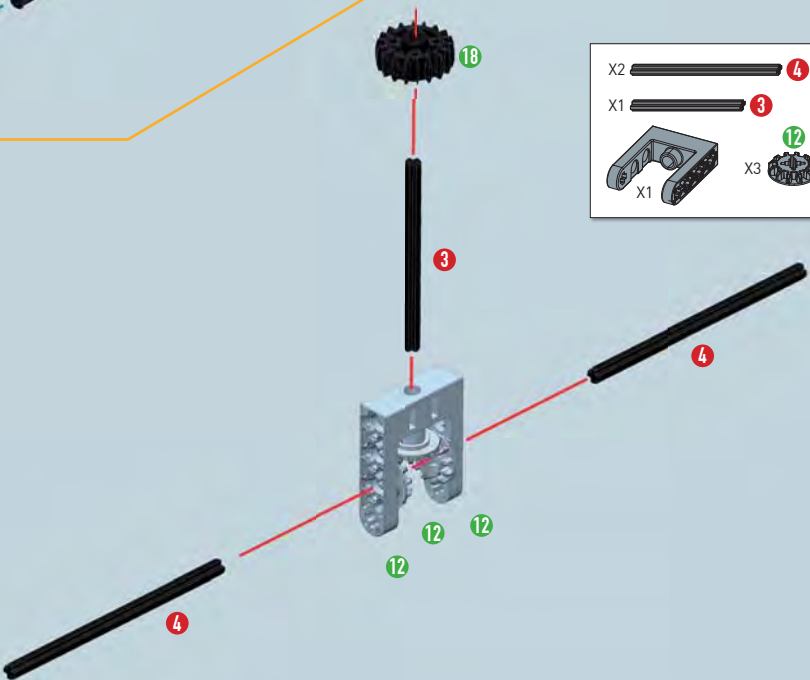

13

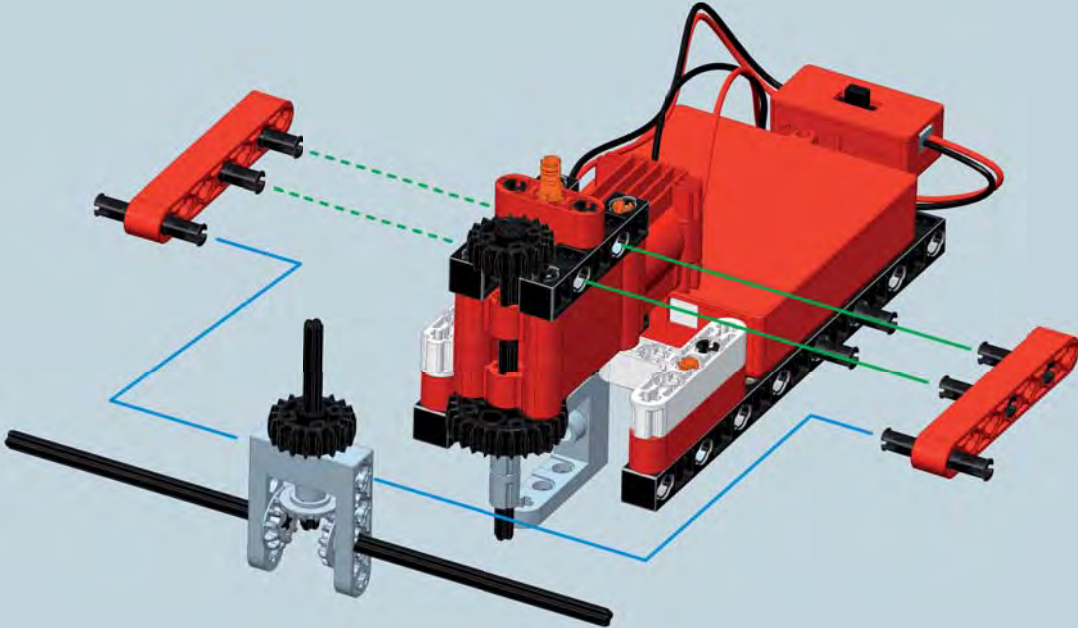

1:1

1:1

14

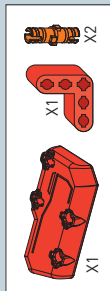
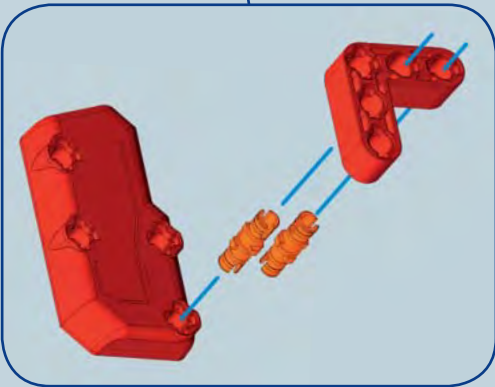
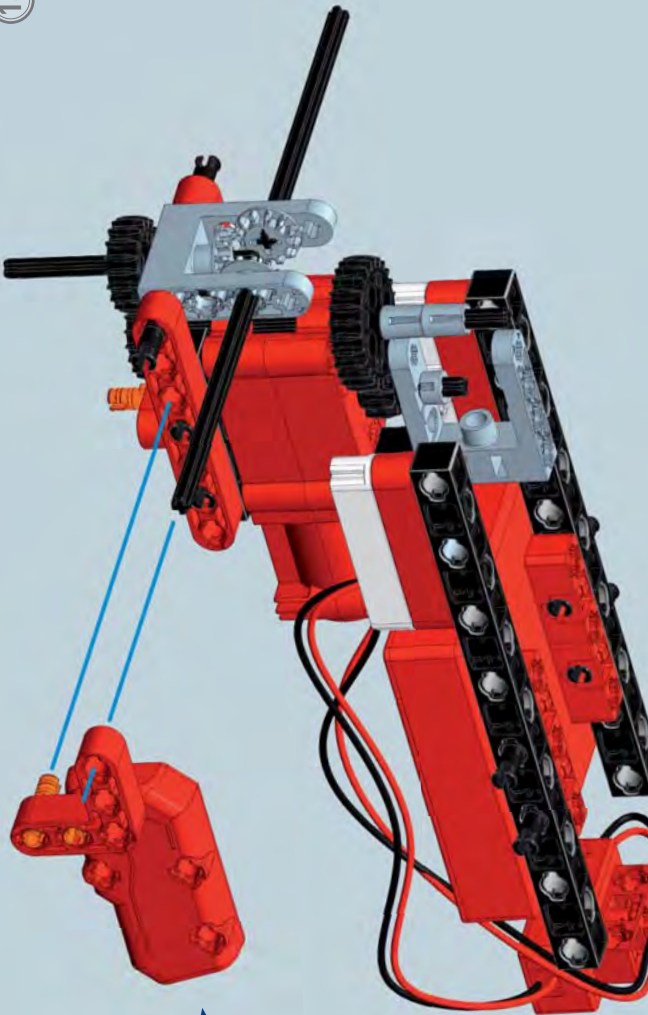

15

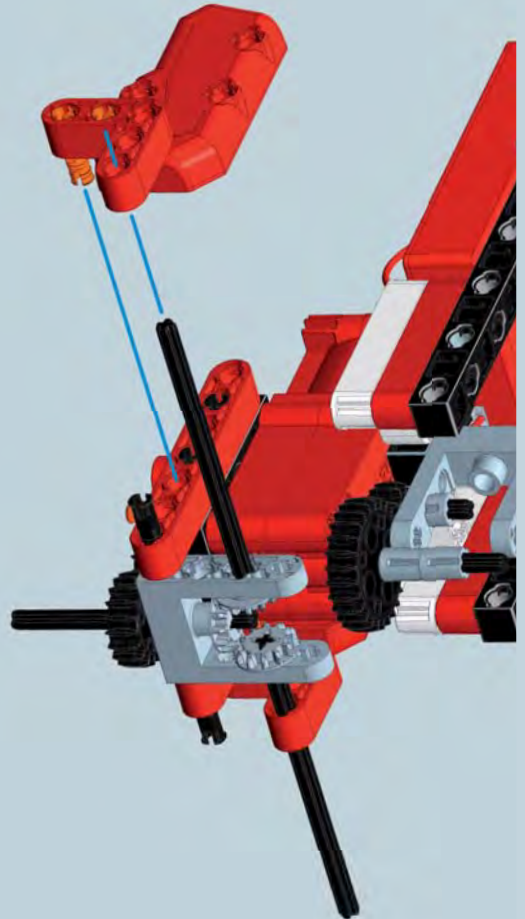
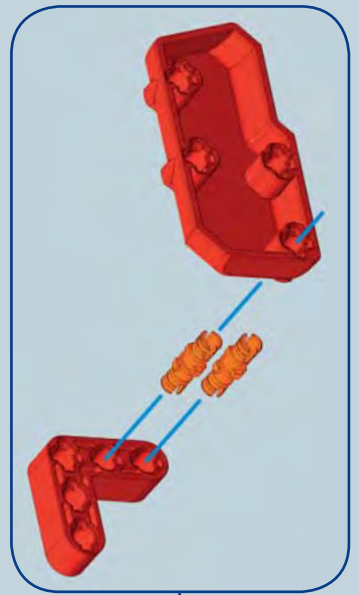
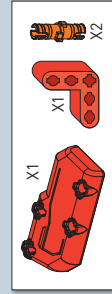

16

- X1
- X1
- X1
- X1
- X1

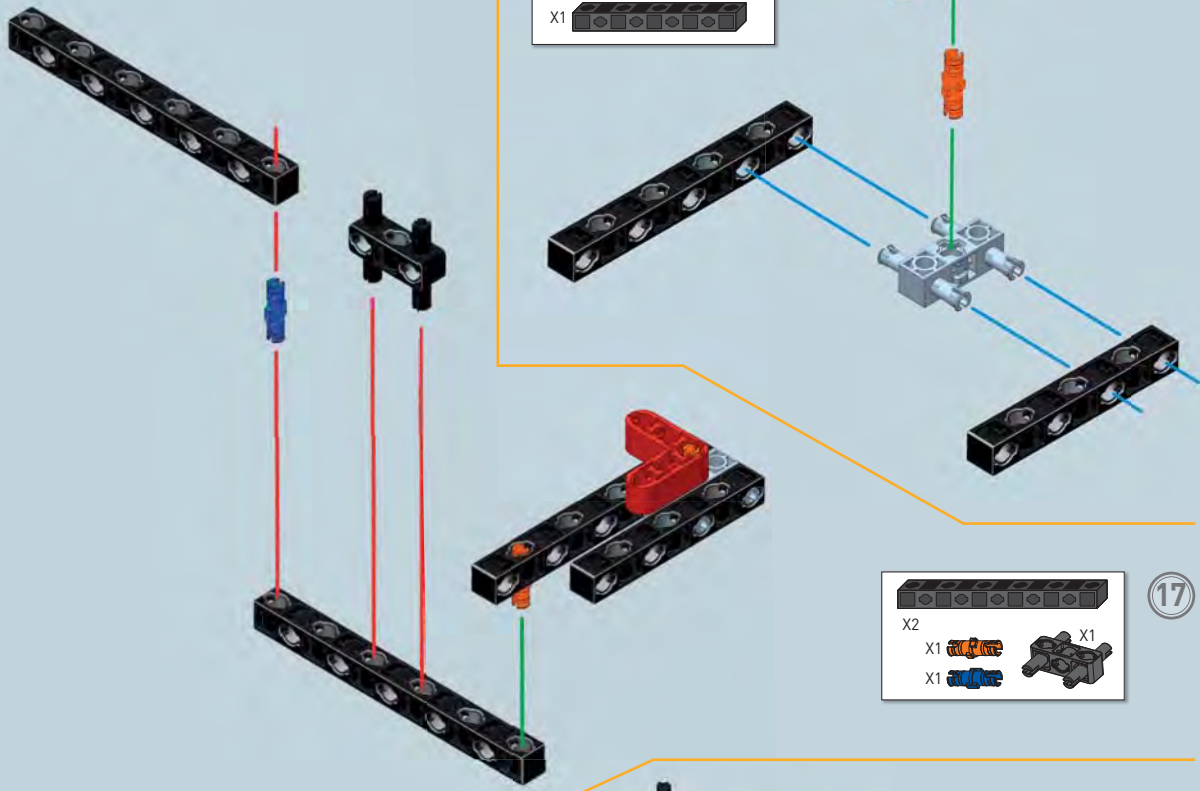

17

- X2
- X1
- X1
- X1

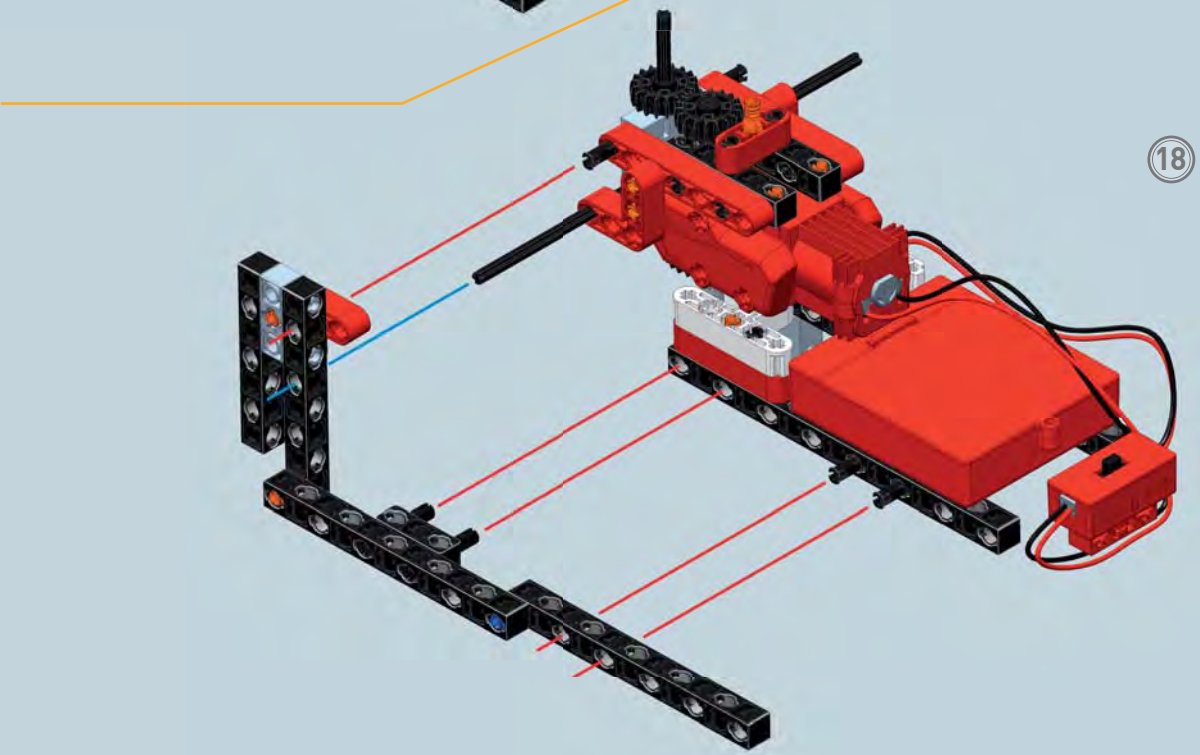

18

19

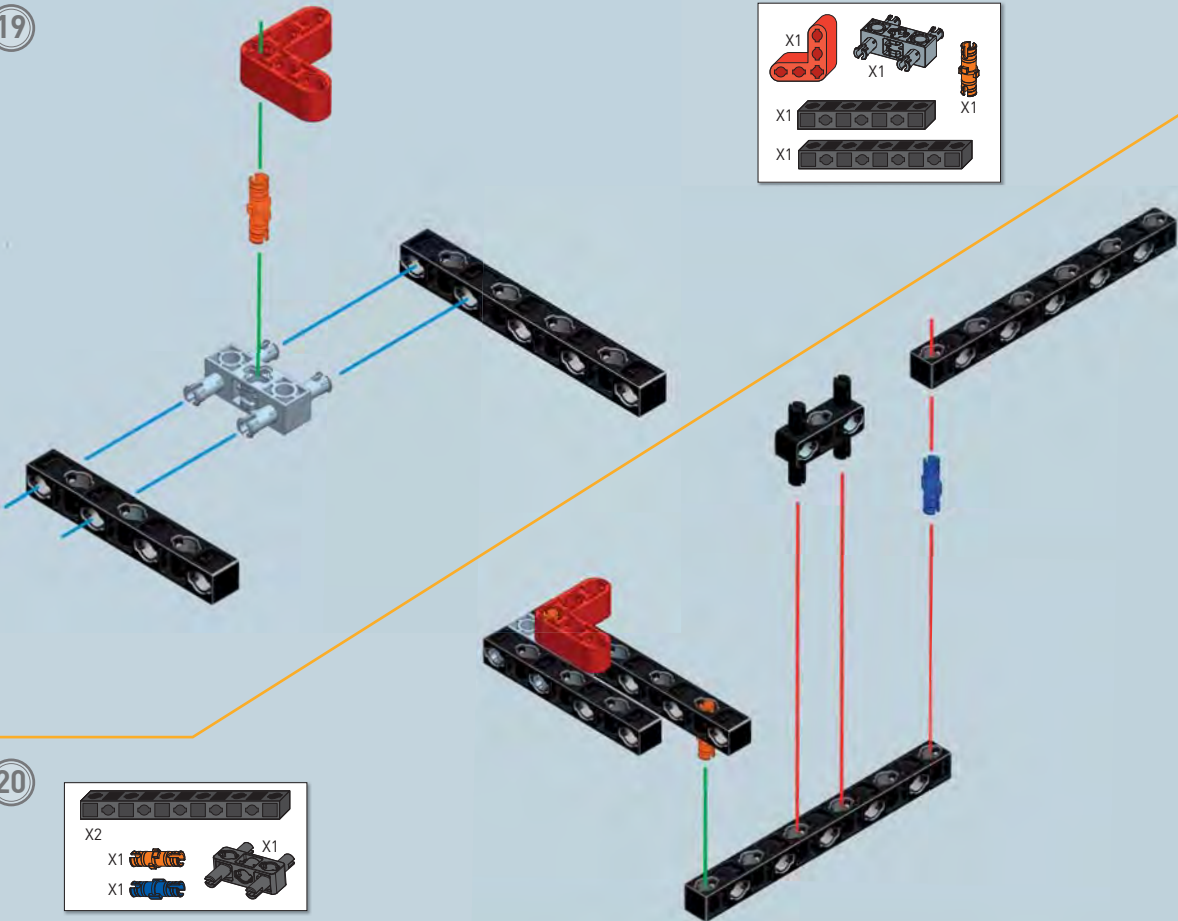
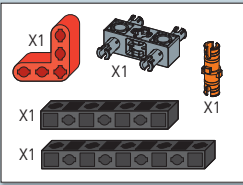

20

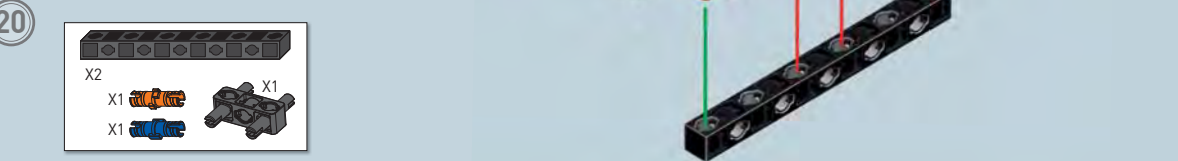
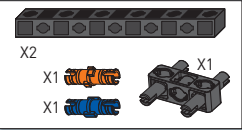



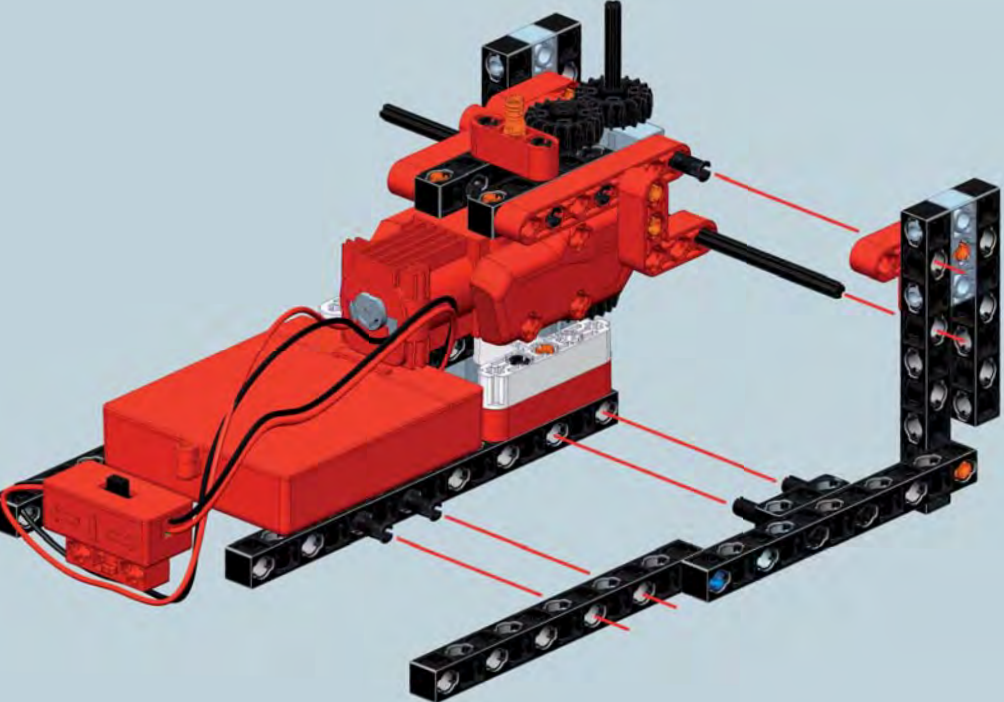

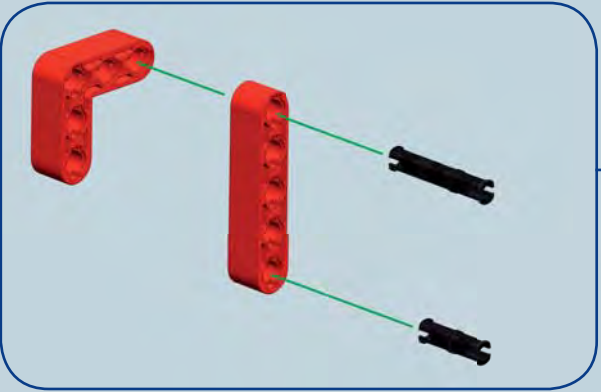
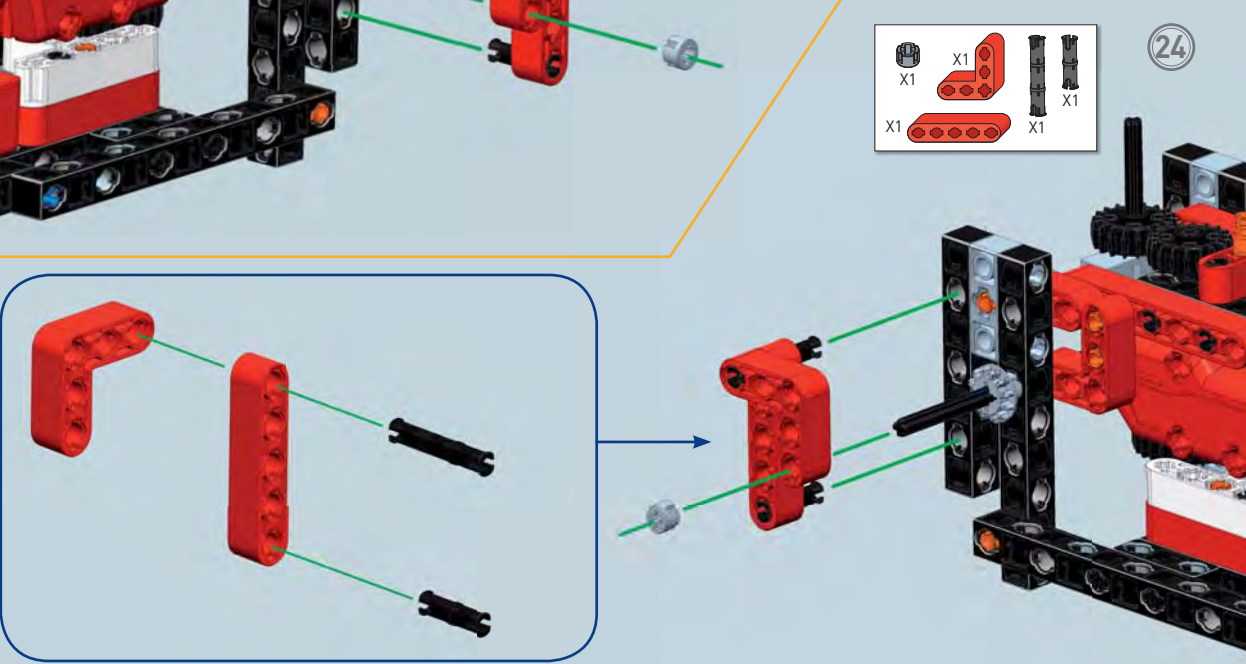
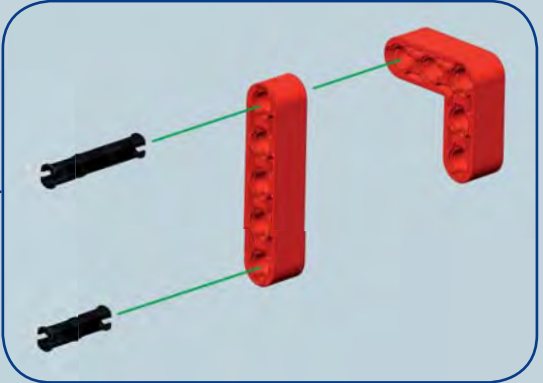
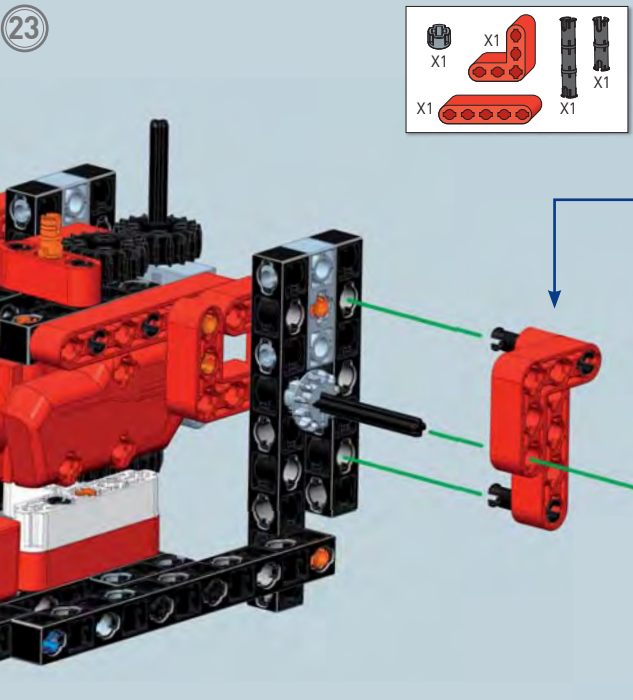
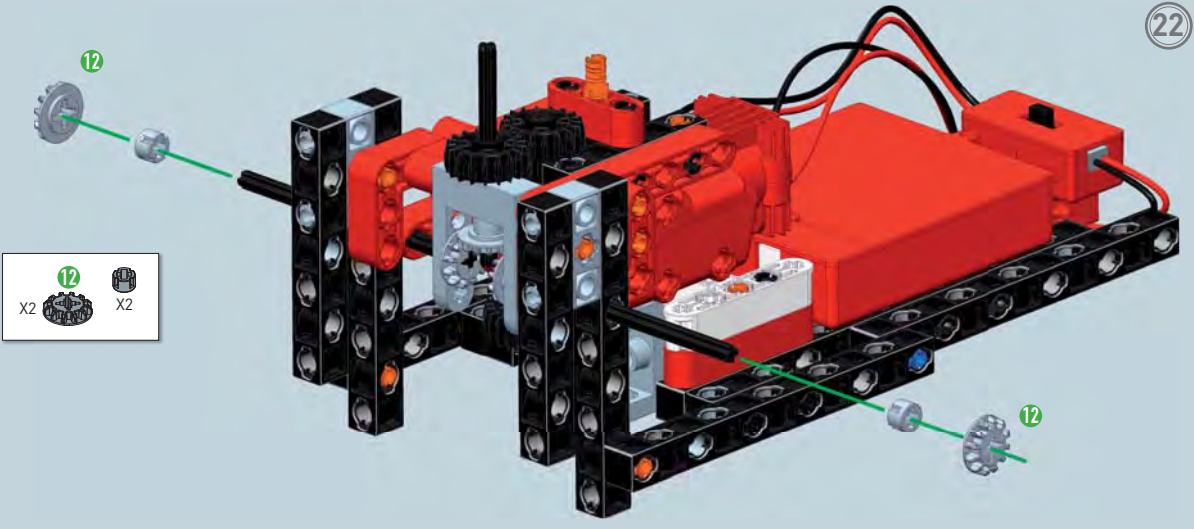

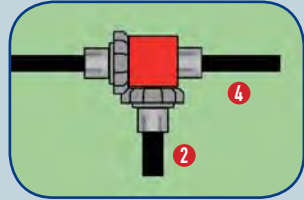
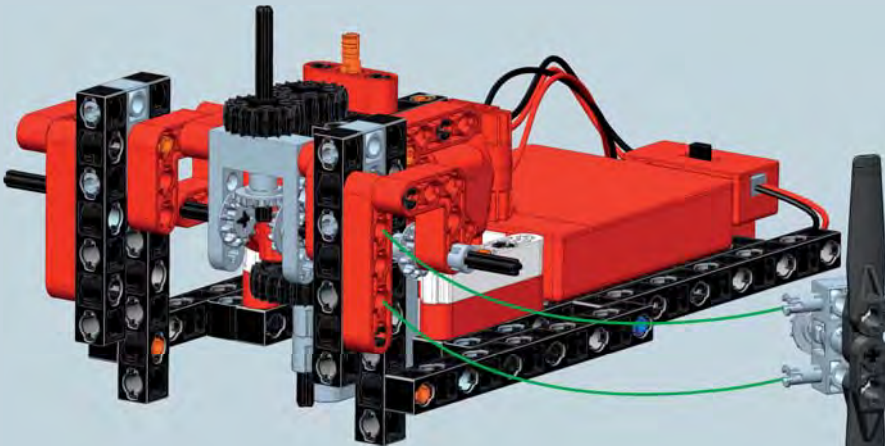
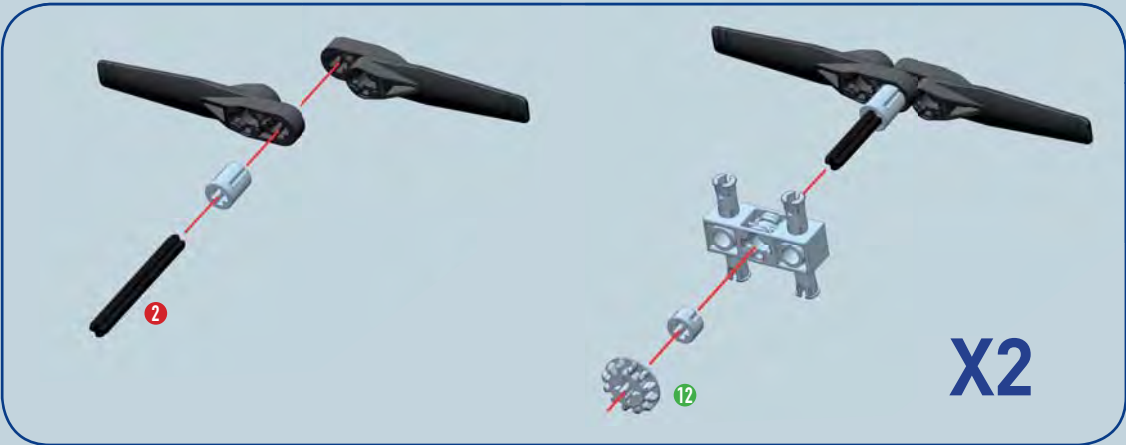
21







- | | | | | | |
|----|--|---|-----------|---|---|
| X2 |  | 2 | X4 |  | |
| X2 |  | | X2 |  | |
| | X2 |  | 12 | X2 |  |

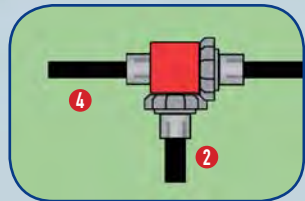
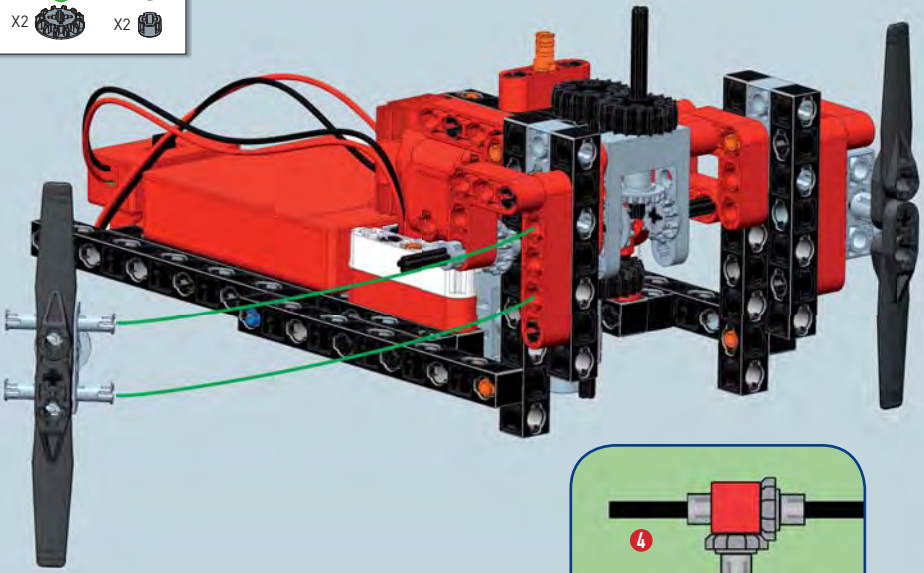

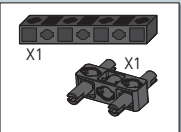
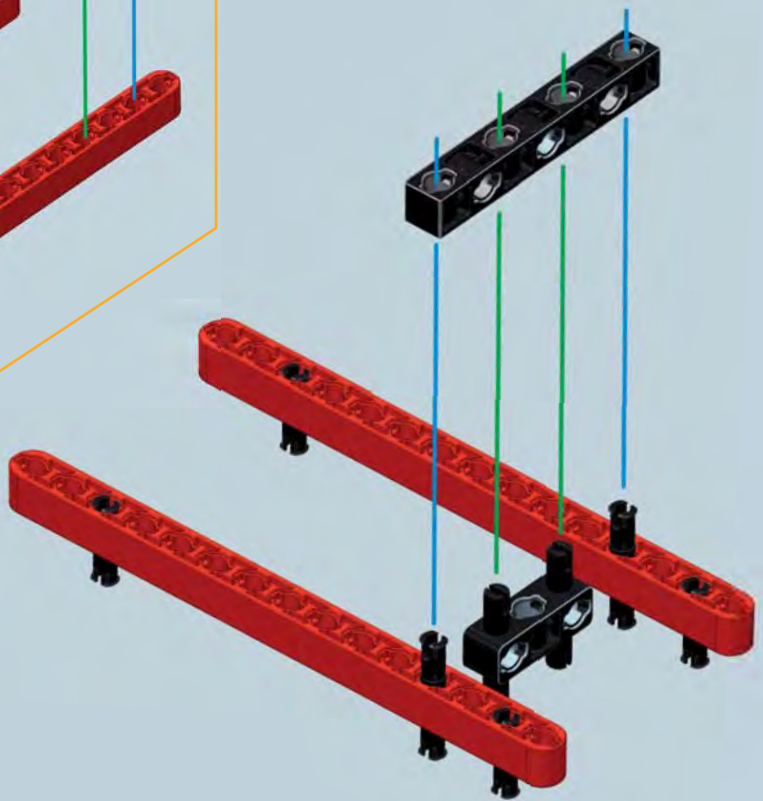
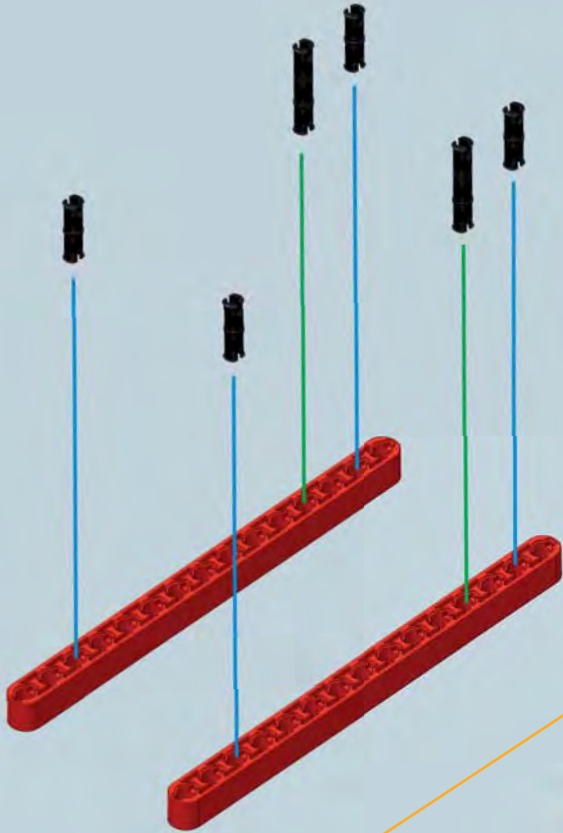
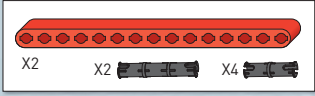
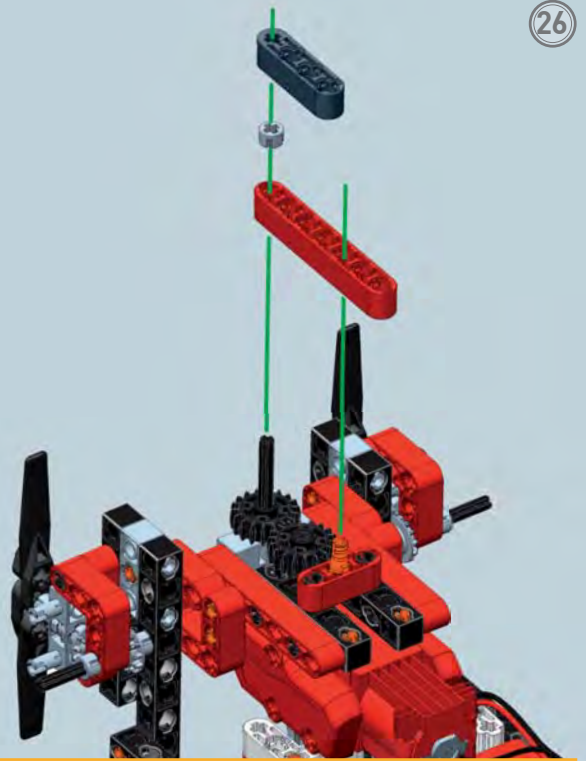
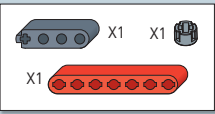

29

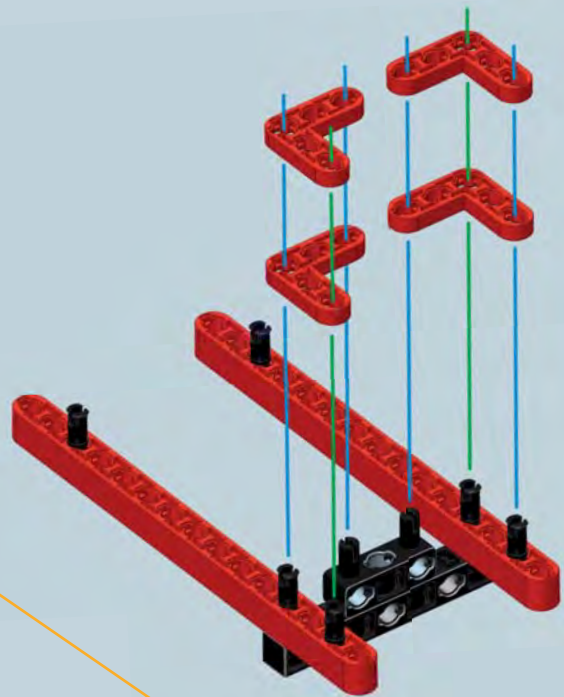

30

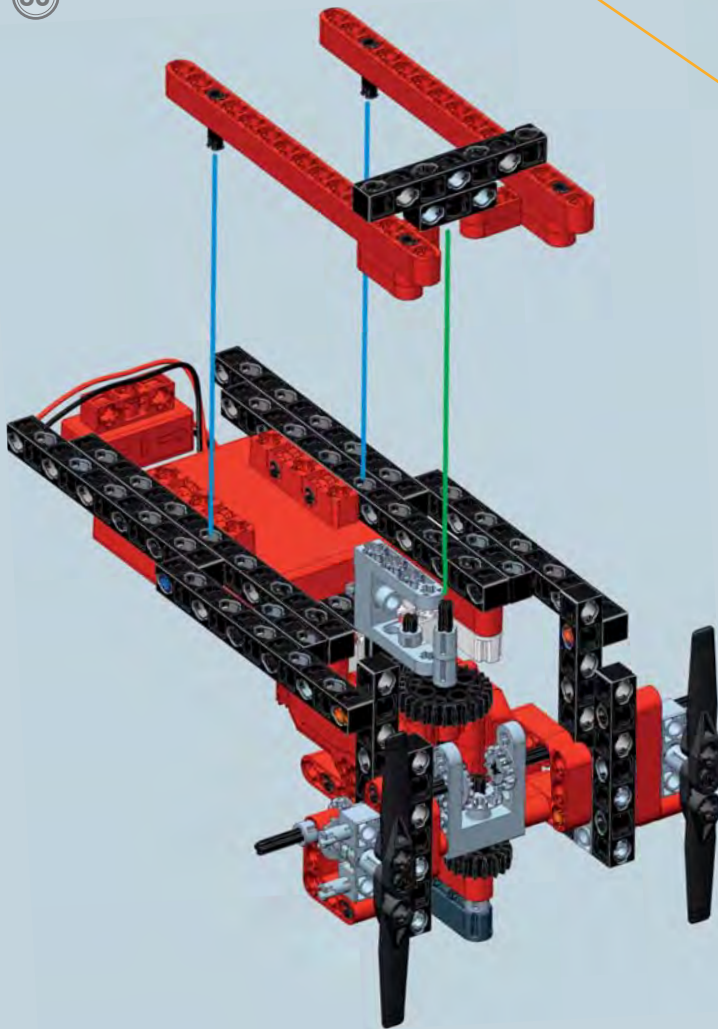

Notizie tecniche e curiosità

L'hovercraft non ha eliche immerse in acqua, perciò la spinta è generata a contatto con l'aria.

Si tratta di eliche spingenti, dalle caratteristiche aeronautiche, montate in posizione posteriore: hanno pale molto sottili che ruotano ad alte velocità.

31

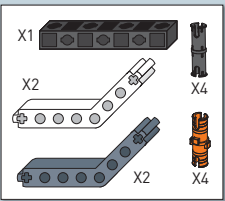
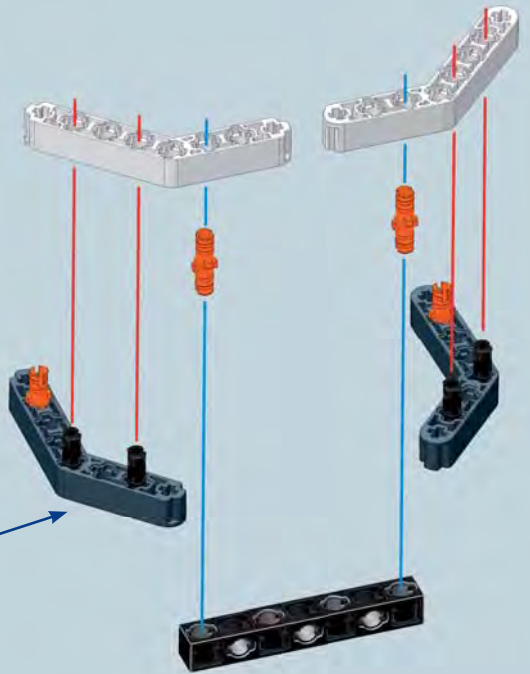
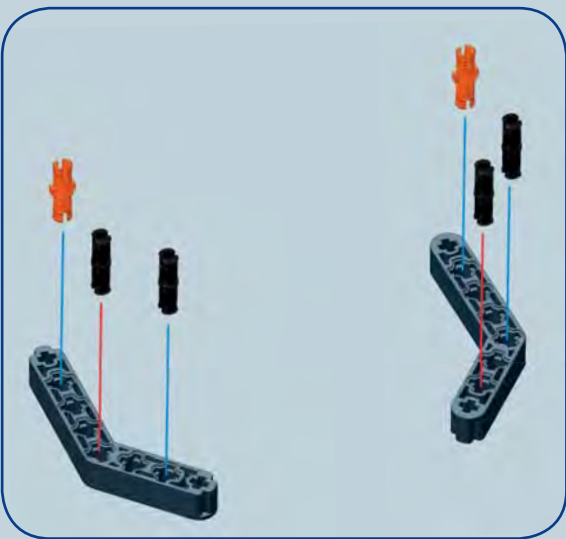

32

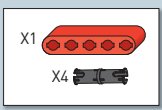
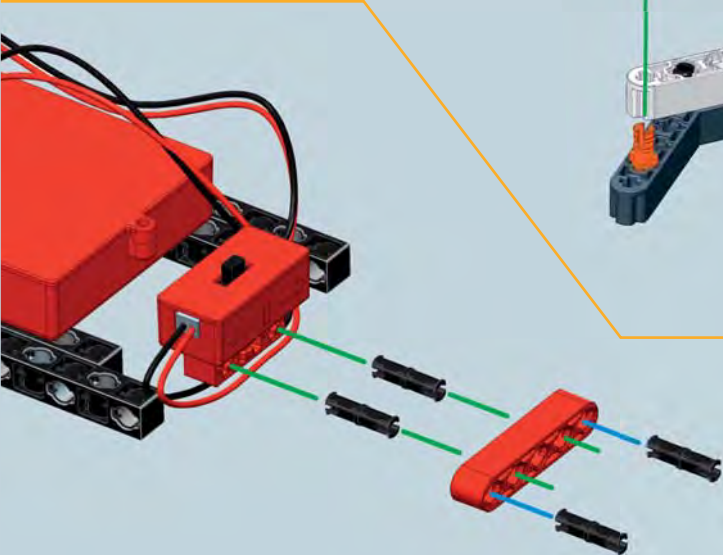
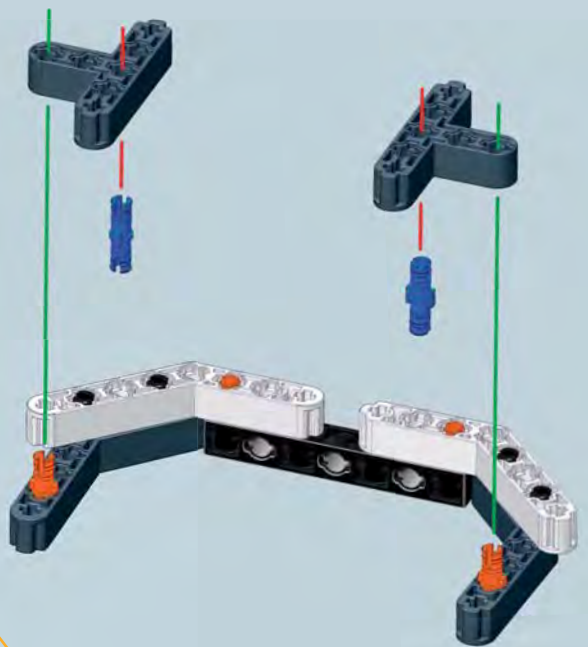
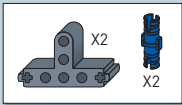

33

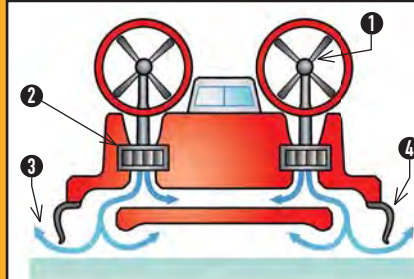
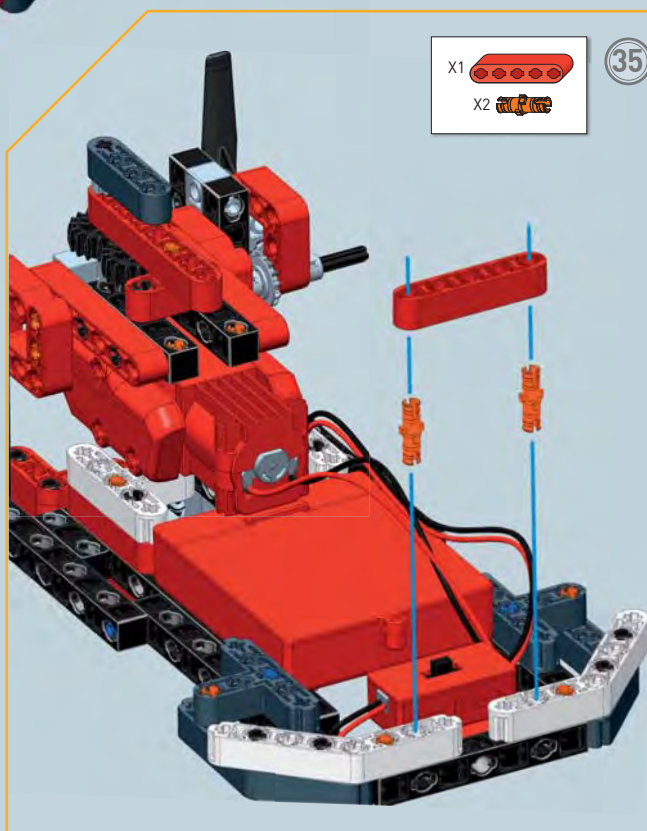
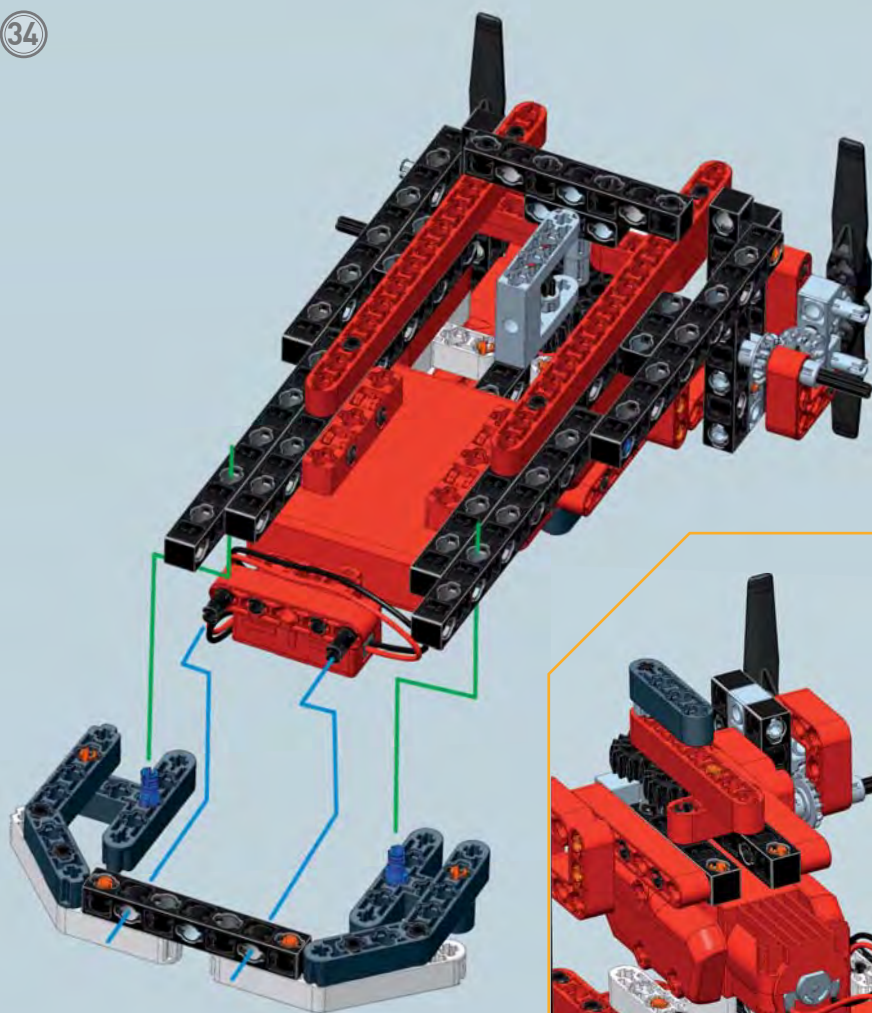

- ① - Eliche
- ② - Turbine
- ③ - Aria
- ④ - Minigonne Flessibili

Notizie tecniche e curiosità

L'aria prodotta dalle turbine e convogliata alle gonnelle crea un flusso costante di uscita verso la superficie. Questo effetto "galleggiamento" permette all'hovercraft di alleggerire il suo peso e scivolare sull'acqua. La coppia di eliche viene utilizzata per la propulsione e la virata, ma è utile anche per diminuire la velocità in caso di rallentamento.



Notizie tecniche e curiosità

Il cuscino d'aria gli permette di spostarsi su terreni fangosi e paludosi come se fosse su terreni compatti e le gonnelle flessibili evitano danni al veicolo.

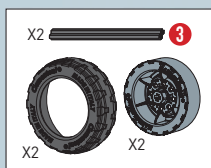

36

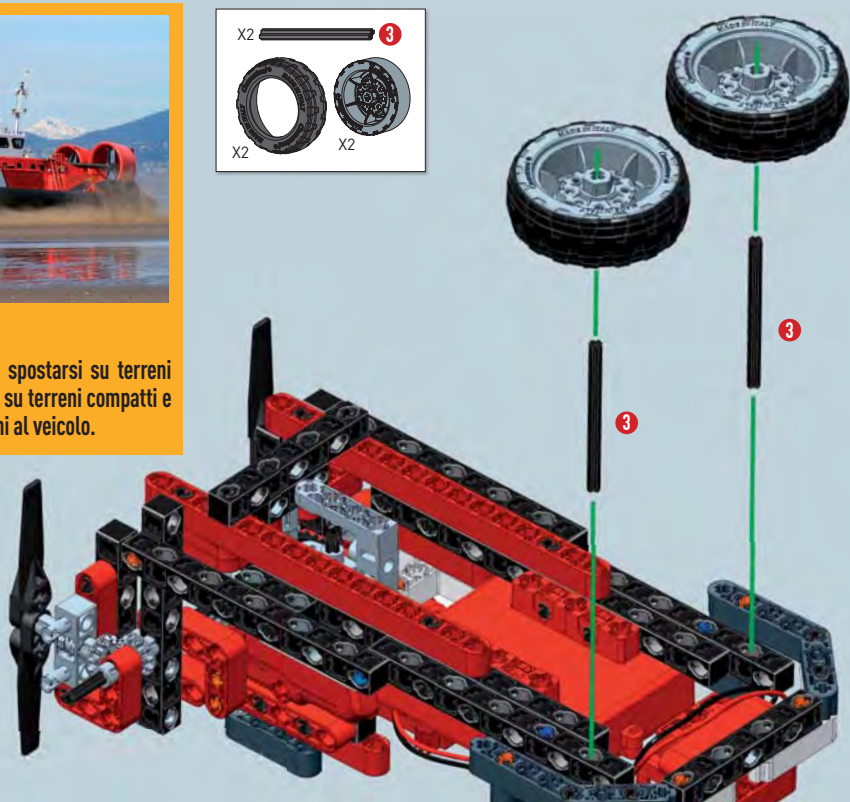

37

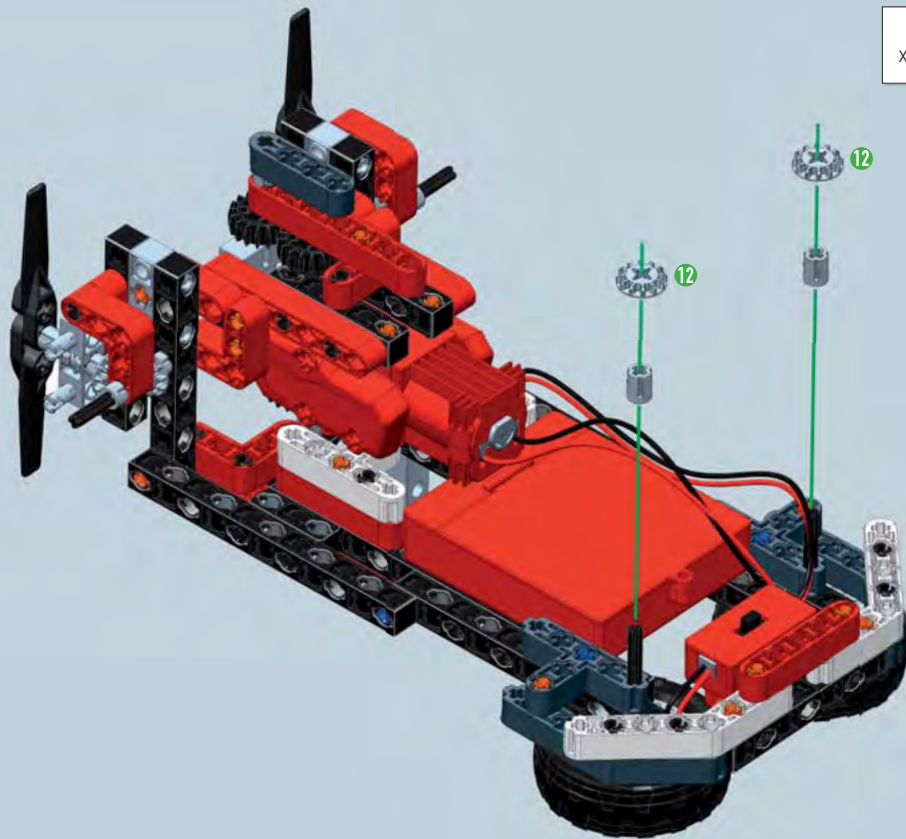



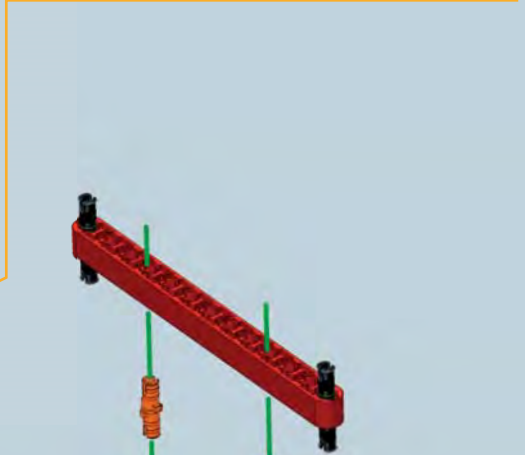
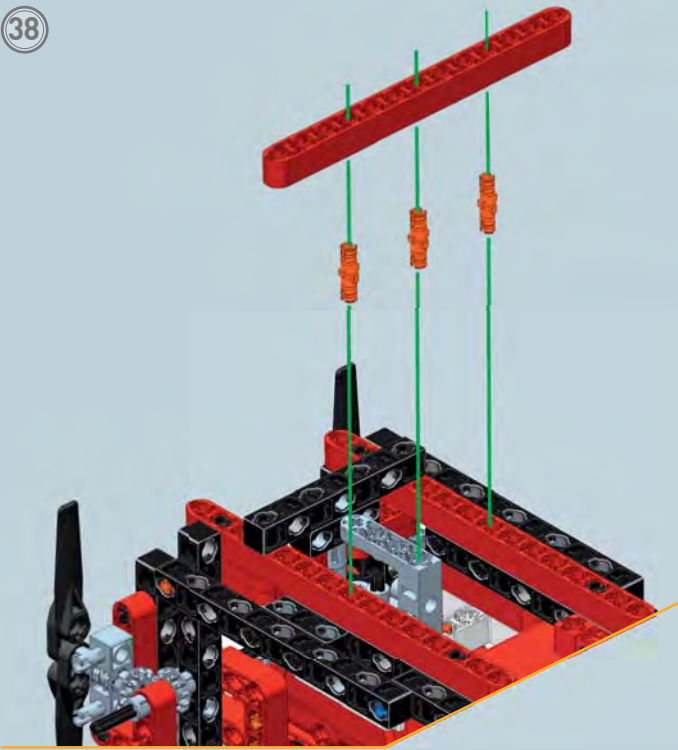
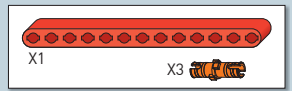



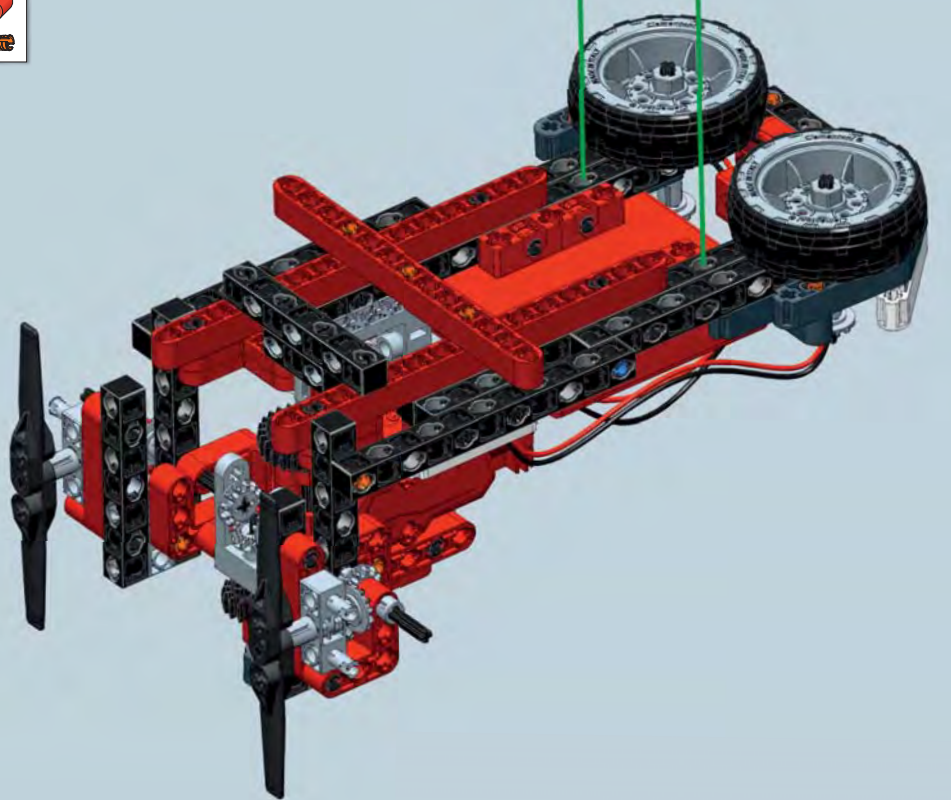
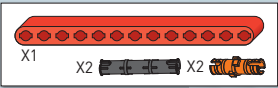

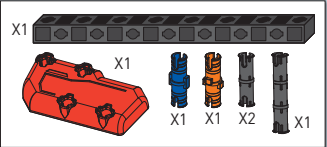
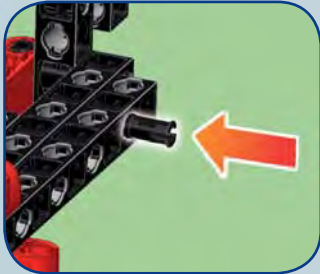
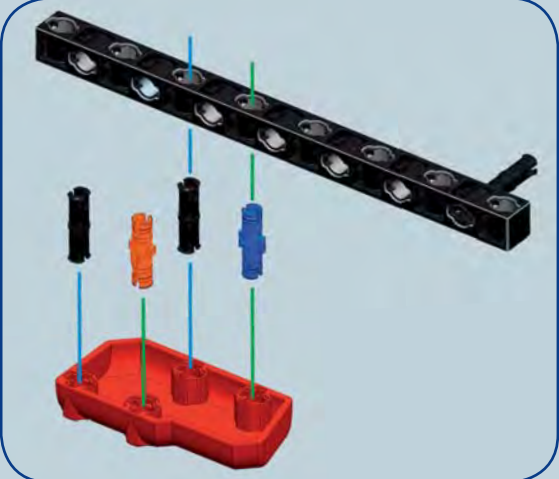
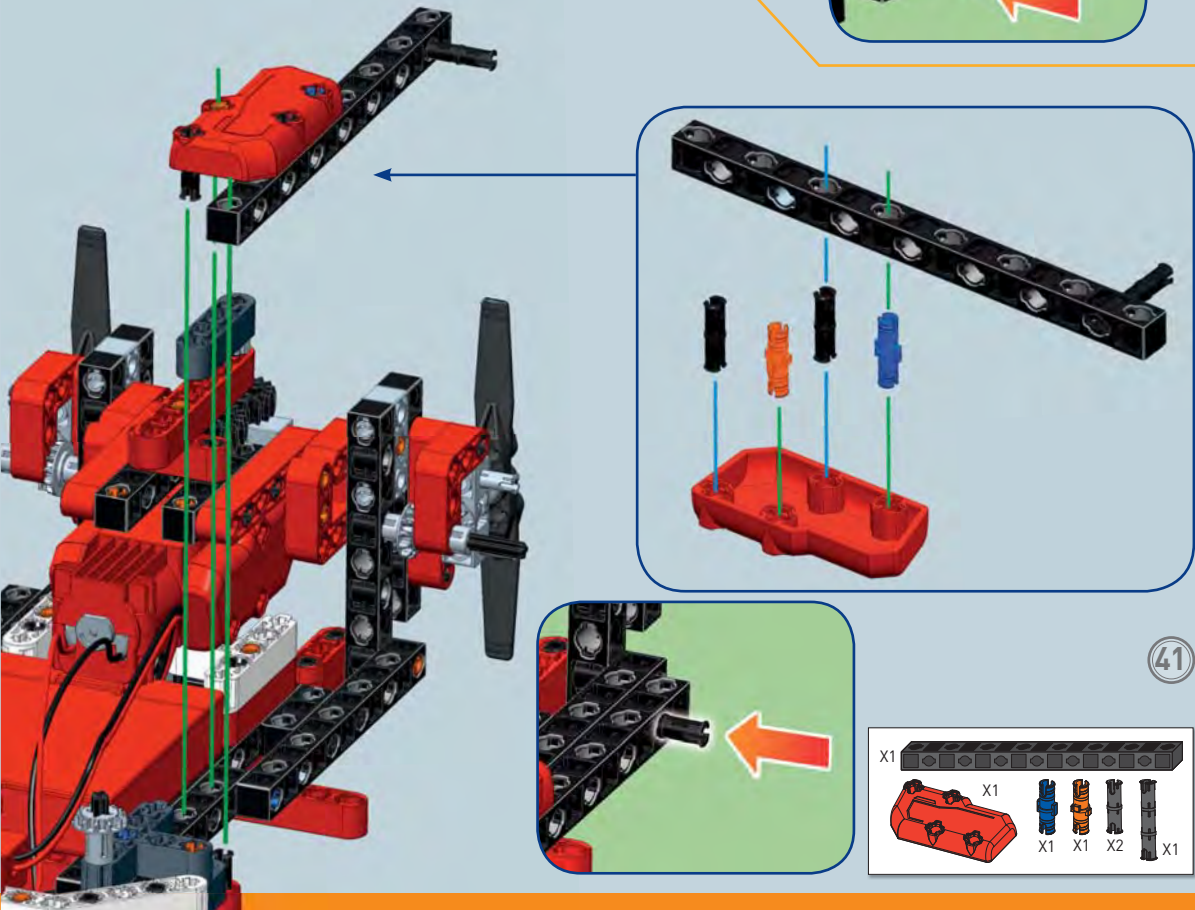
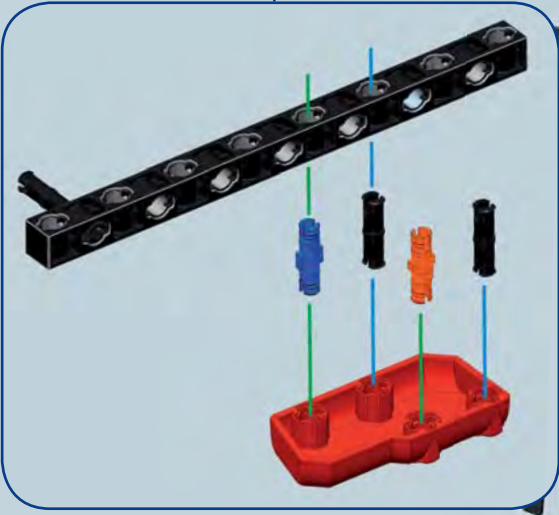
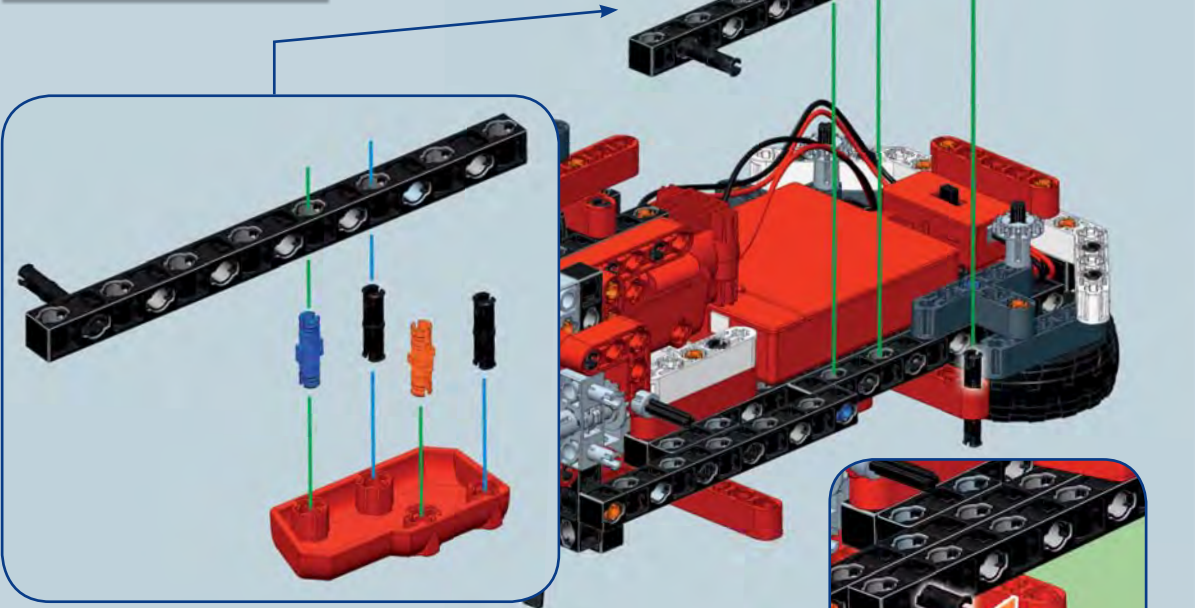
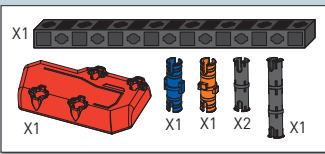
38



39





- X2  3
- X2  
- X4  X2
-  X2 
- X4  X2 

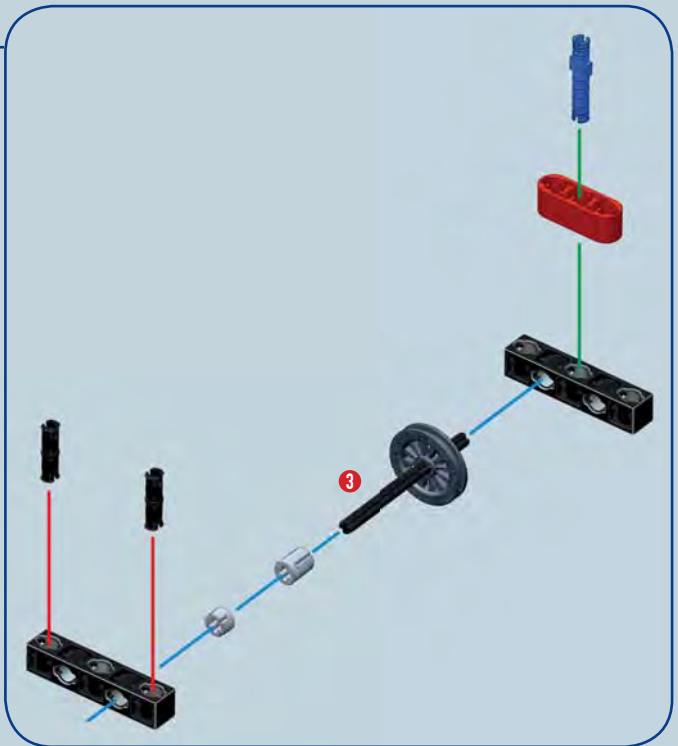
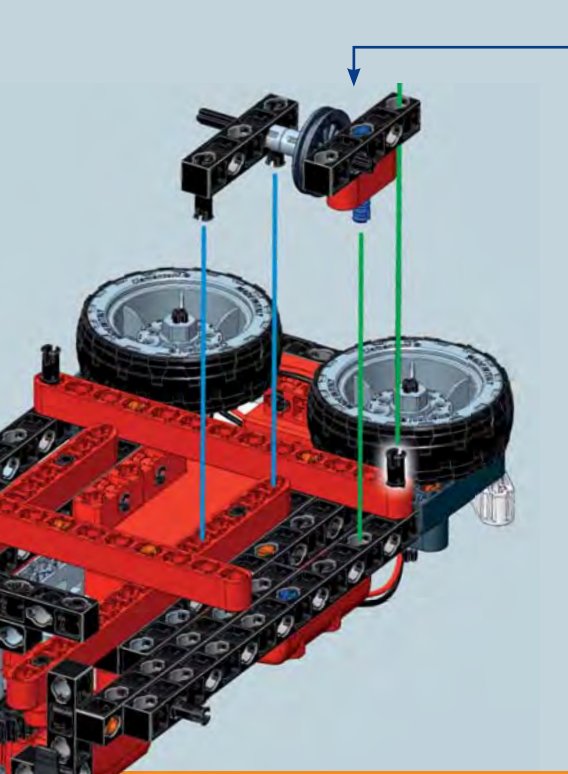
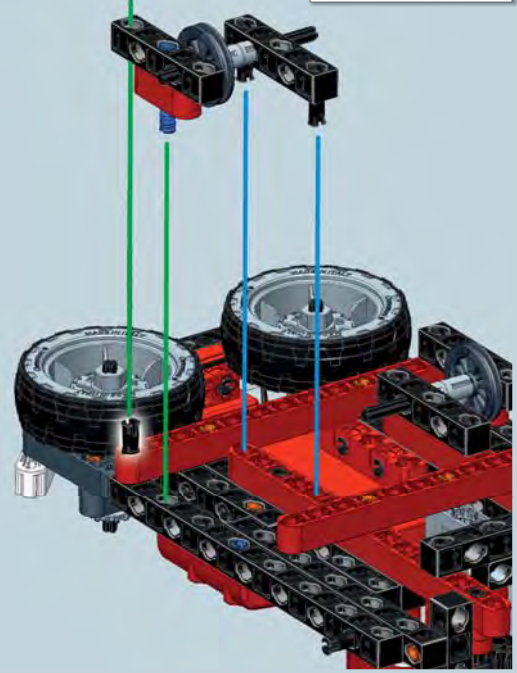
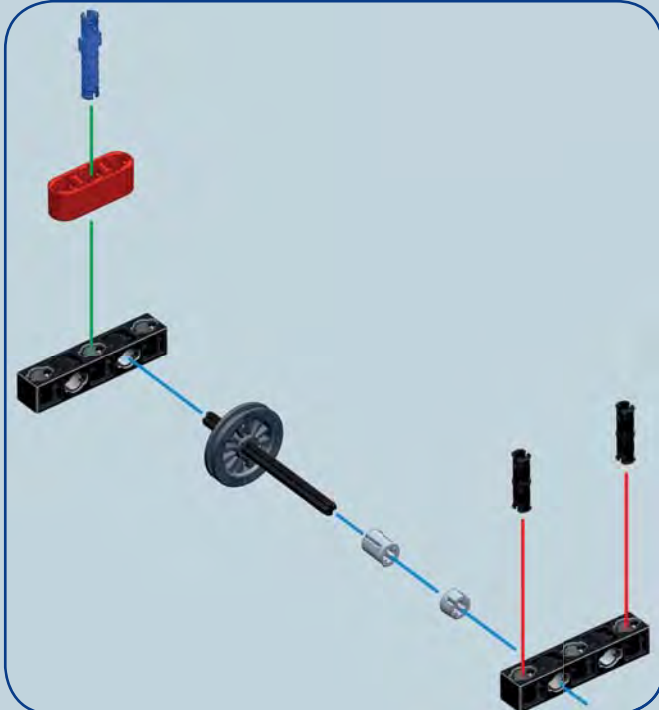

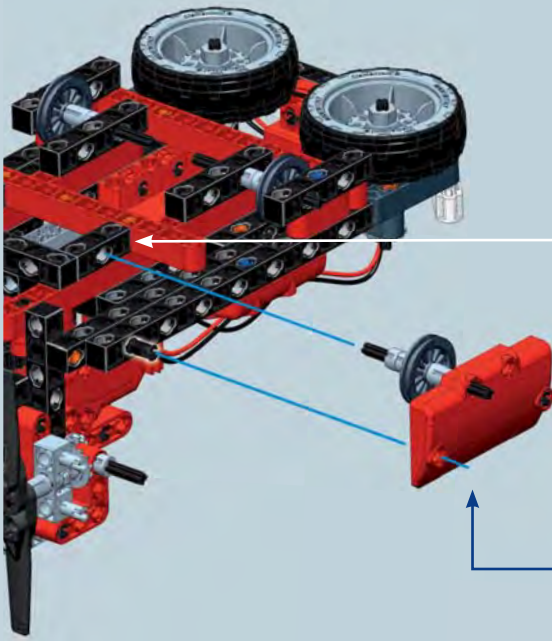

43

- X1 3
- X1
- X1
- X1
- X3
- X2
- X1
- X1

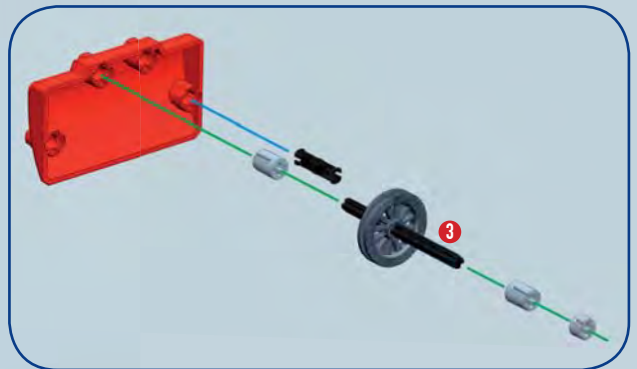
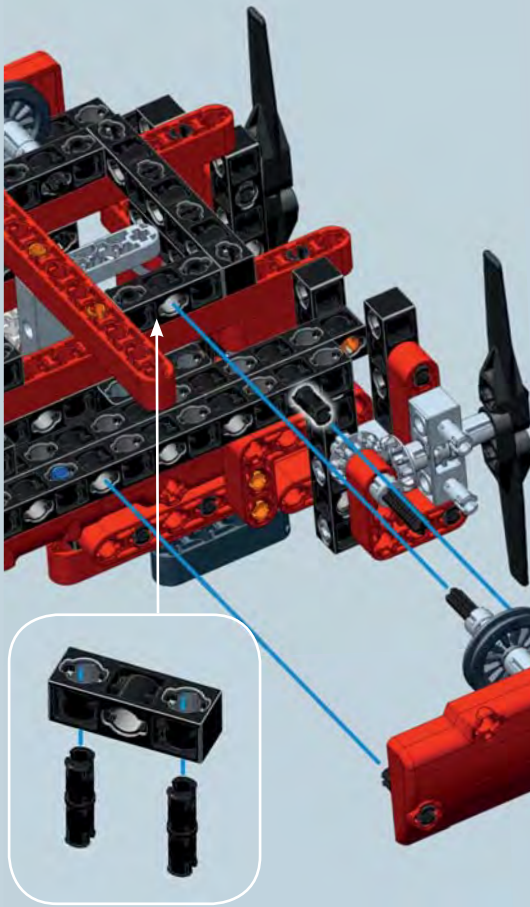
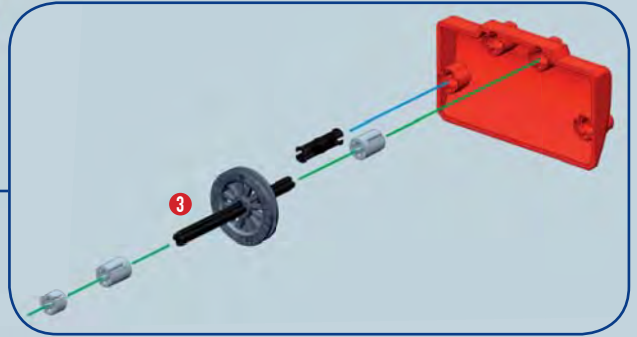

44

- X1 3
- X1
- X1
- X1
- X3
- X2
- X1
- X1

1:1 3

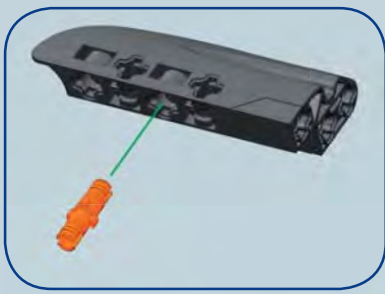

45

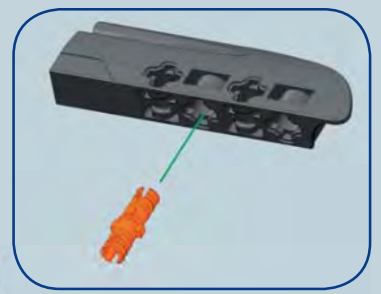
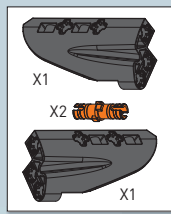

46

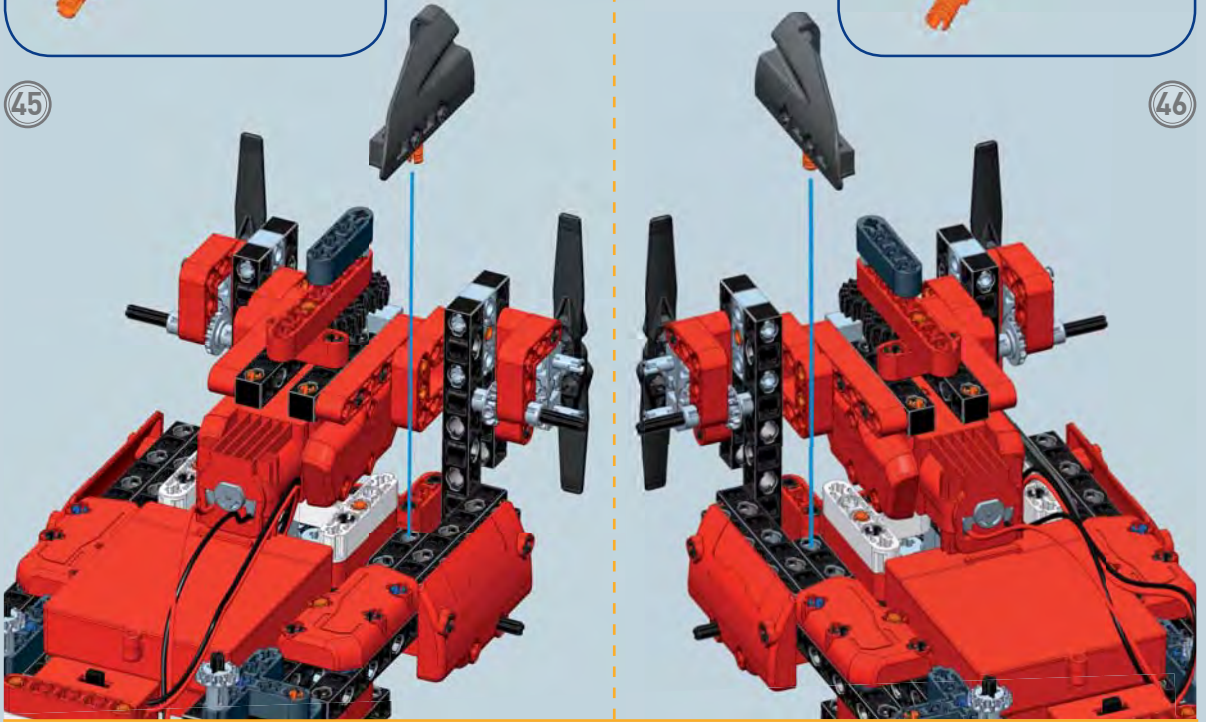

47

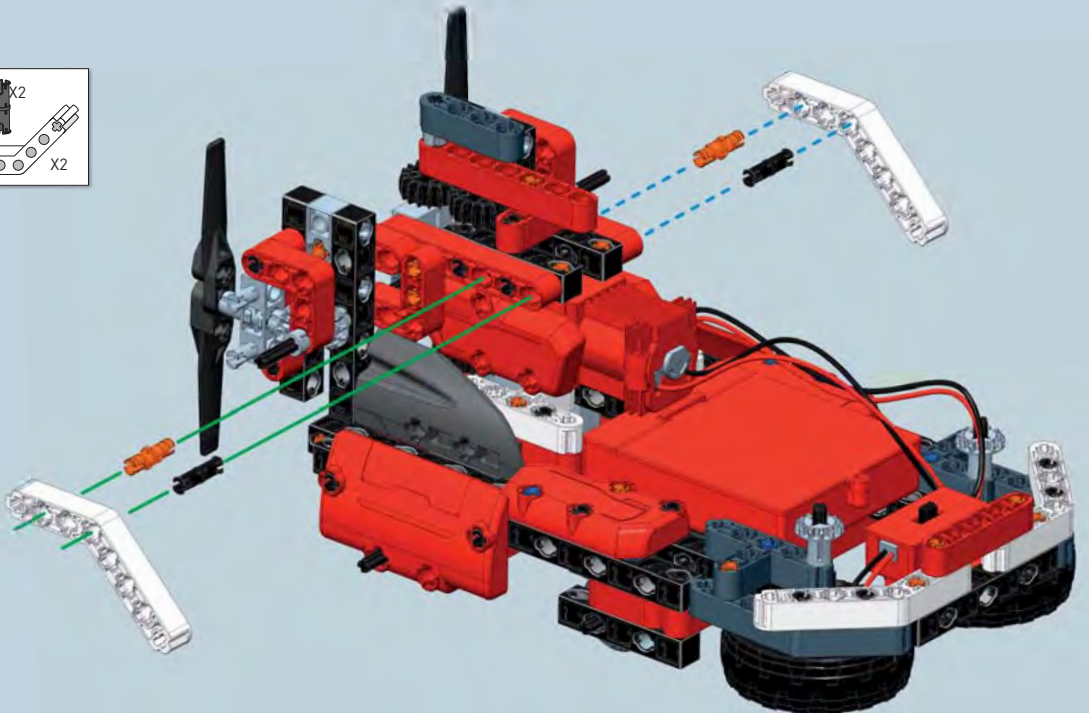
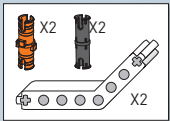

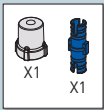

48

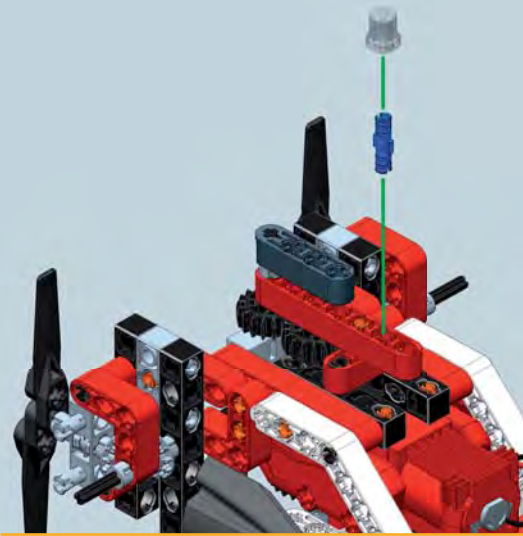

49

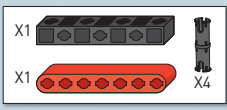
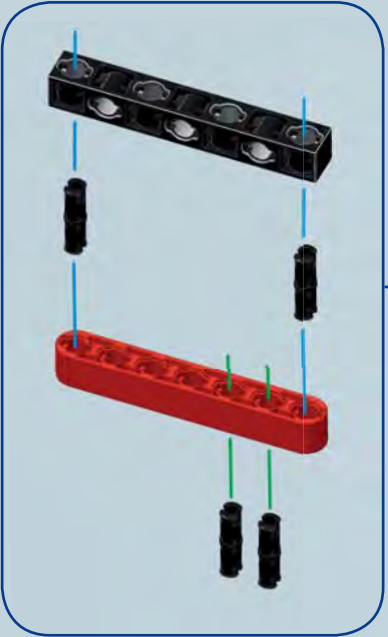
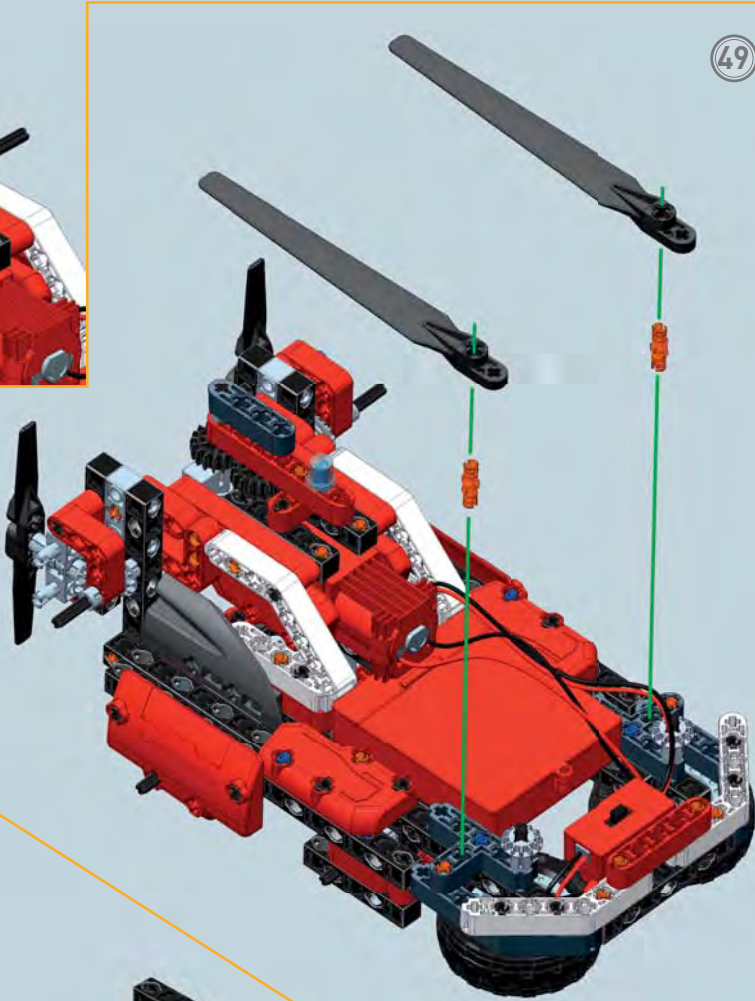
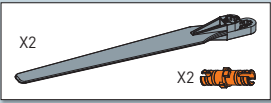

50

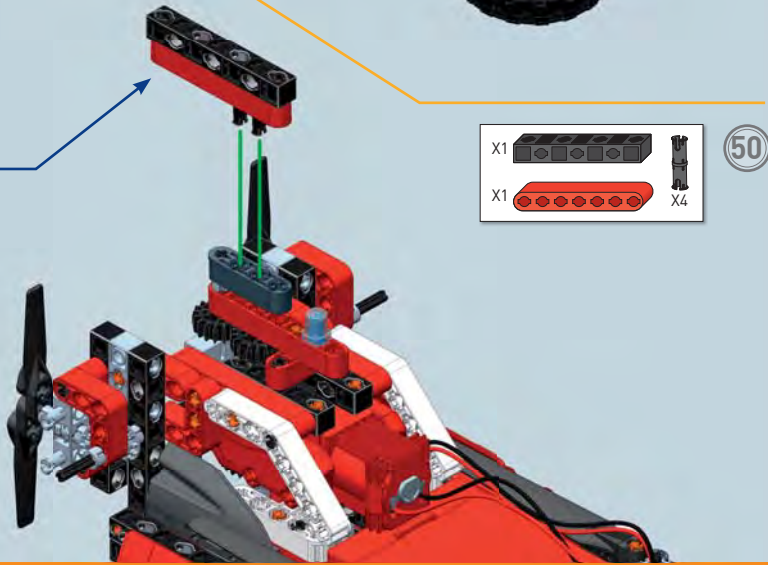

51

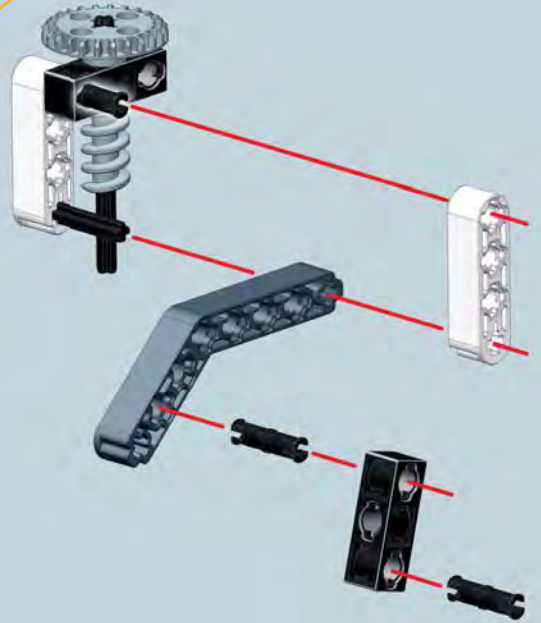
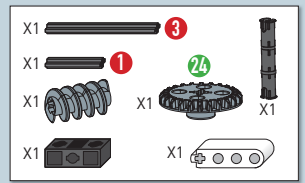
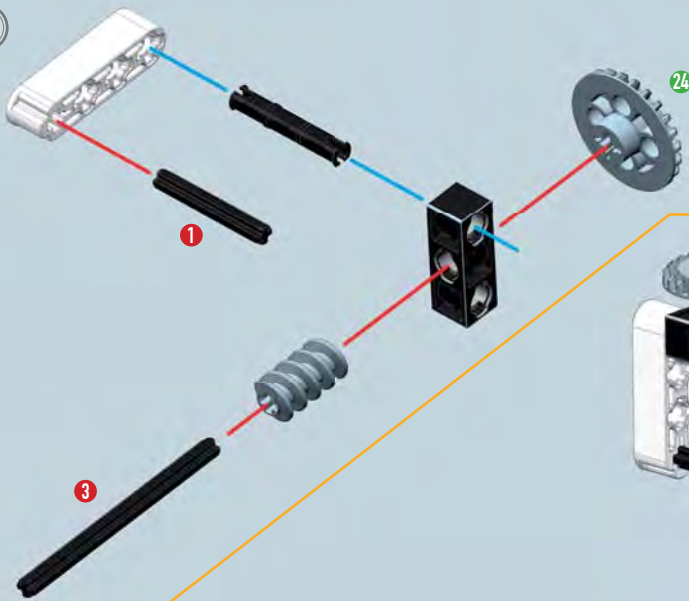

52

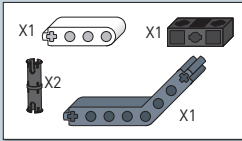

53

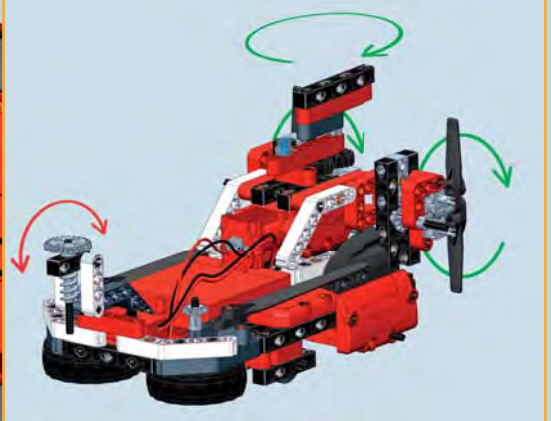
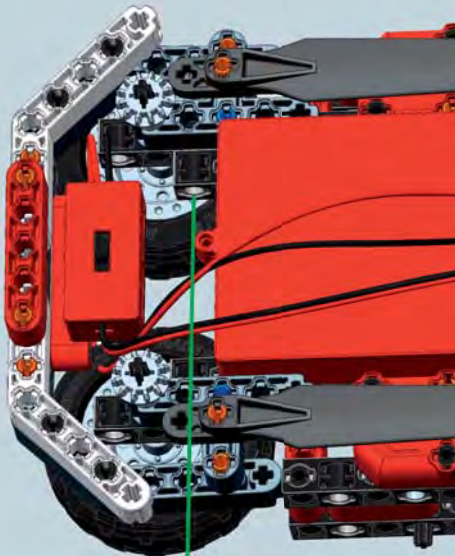

Usa lo switch per attivare la rotazione delle ruote posteriori.





Il carro attrezzi è un veicolo da soccorso stradale realizzato per prestare aiuto ad altri mezzi a motore in difficoltà tecniche e permette il loro trasferimento da un luogo ad un altro.

Nella maggior parte dei casi si occupa del recupero di veicoli che sono usciti fuori strada in luoghi difficili da raggiungere, a seguito di un incidente.

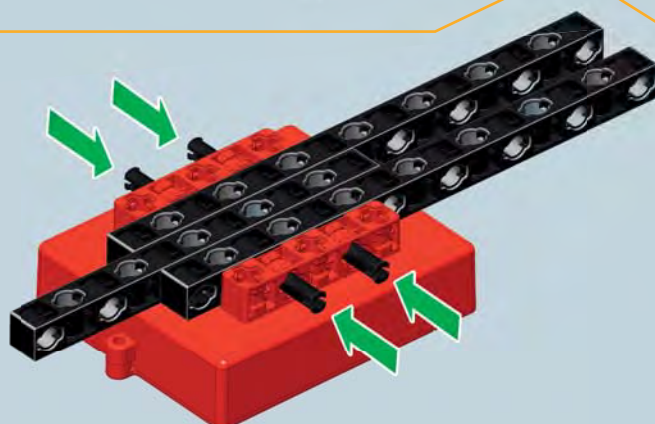
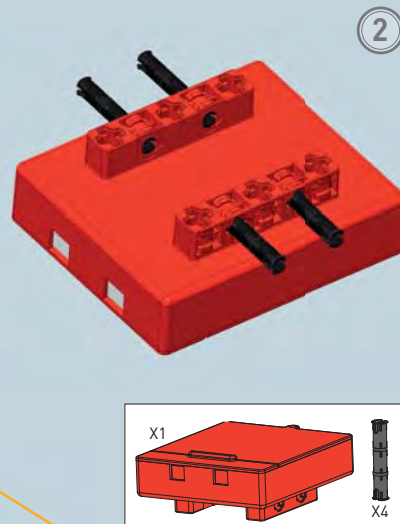
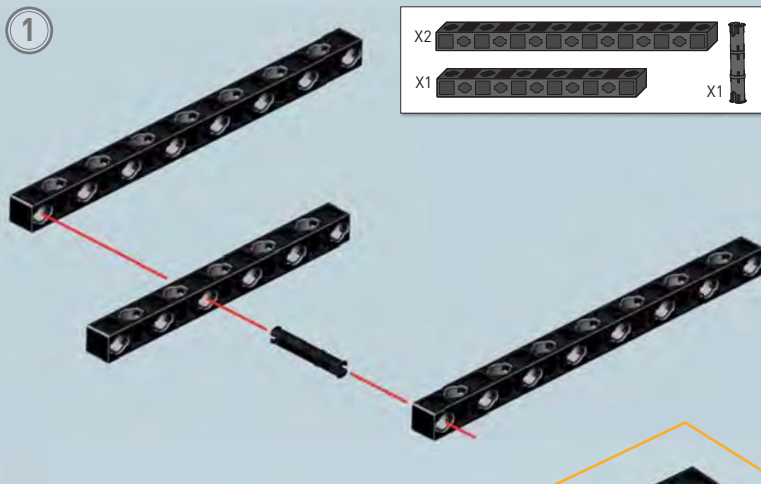

4

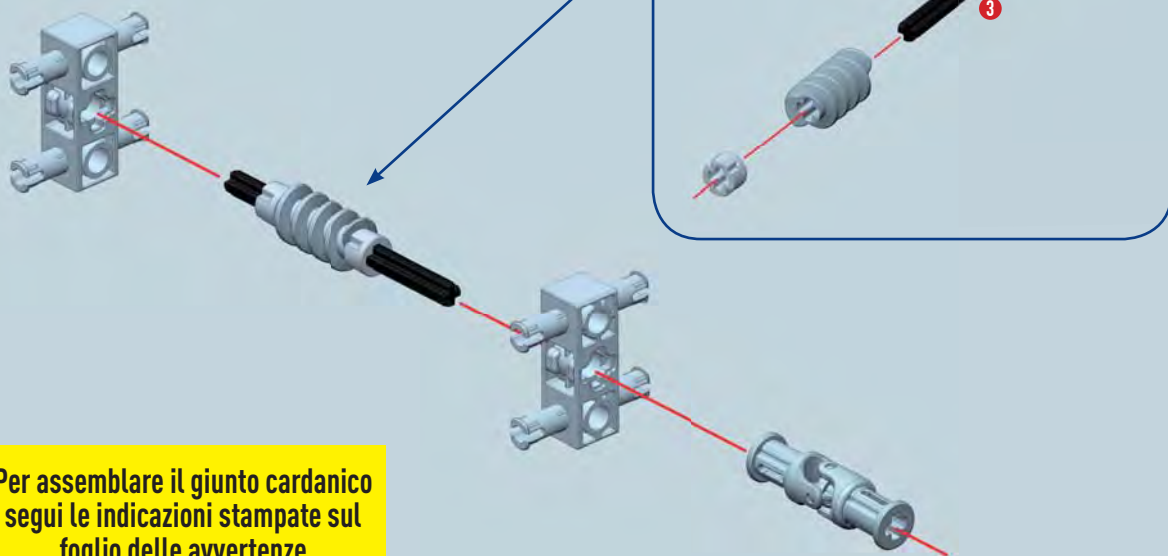
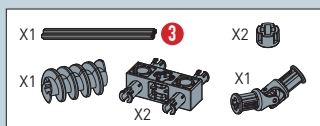

Per assemblare il giunto cardanico
segui le indicazioni stampate sul
foglio delle avvertenze

5

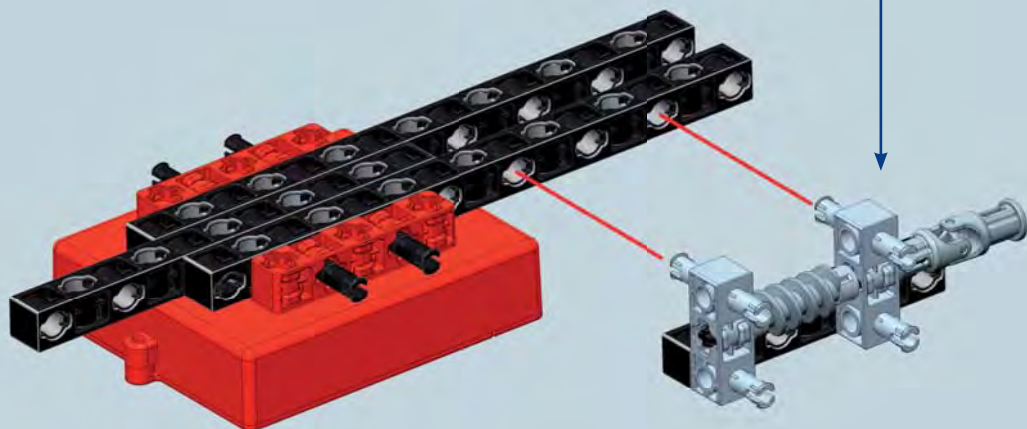
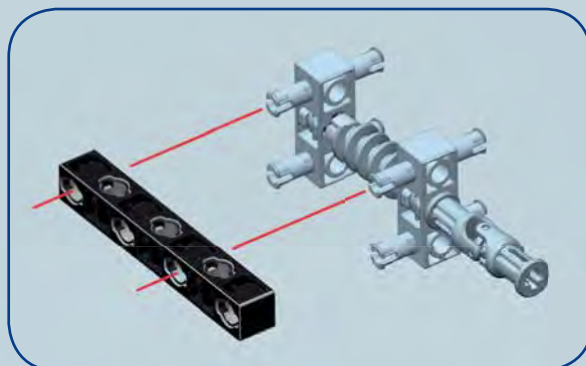

1:1

3

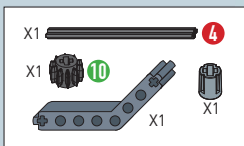

6

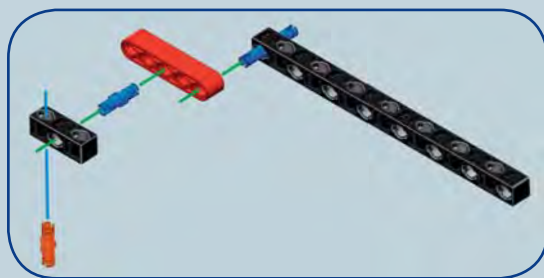
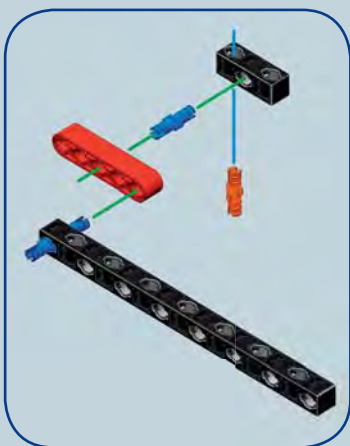
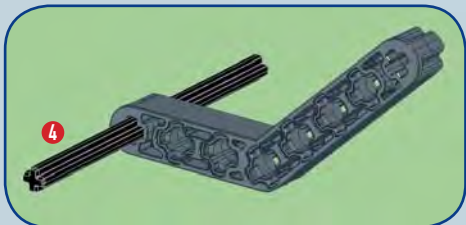
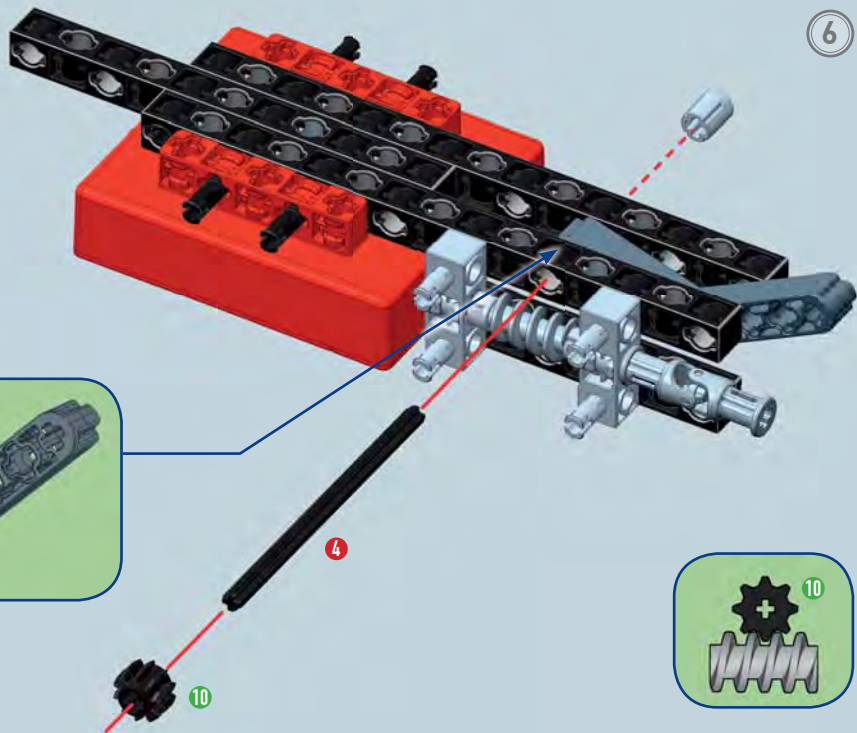

7

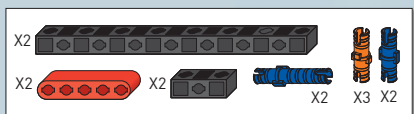
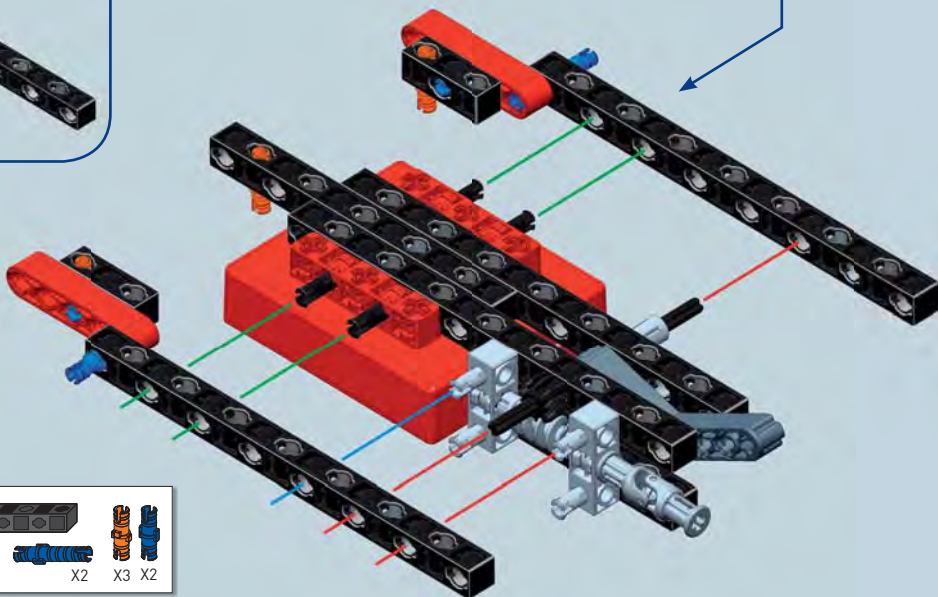

X1  5 X2 

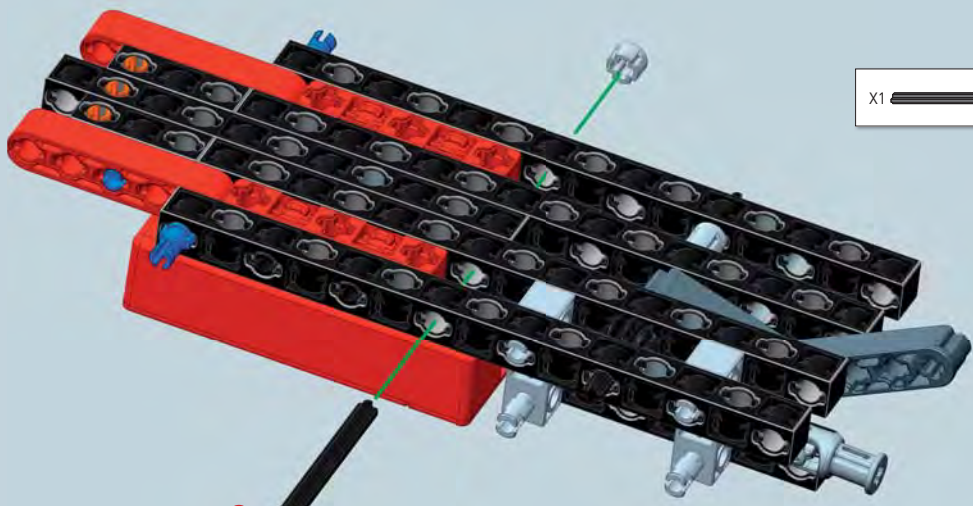

5



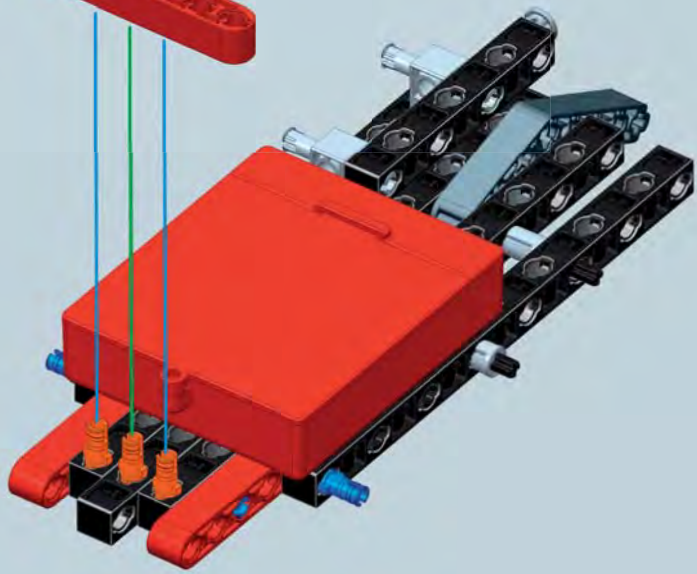
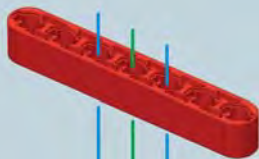

9

X1 



10

X2  X2  X4 



1:1  5 

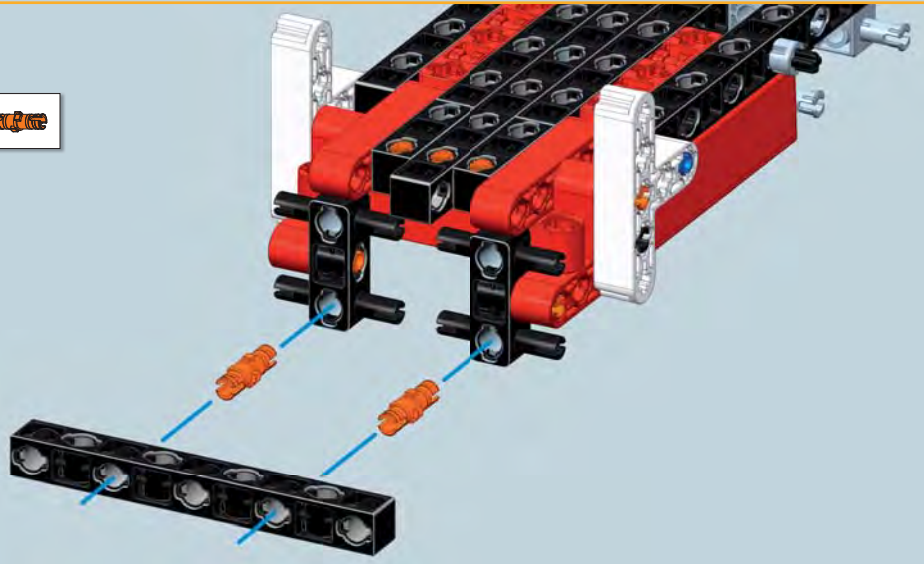
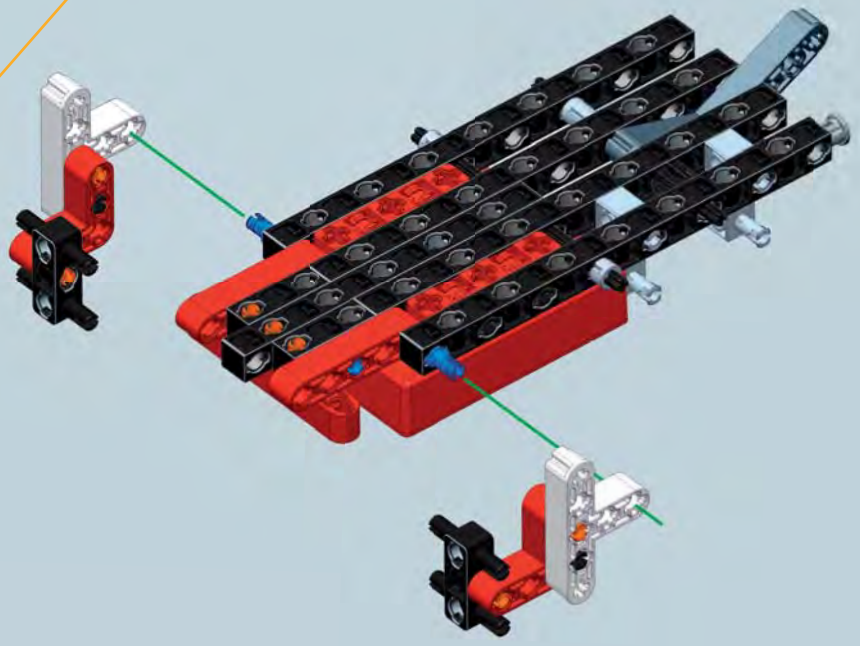
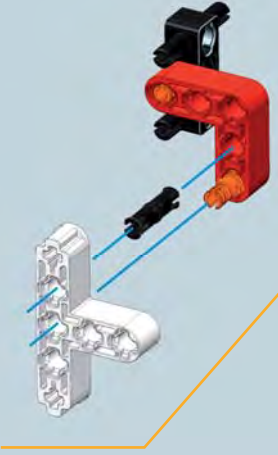
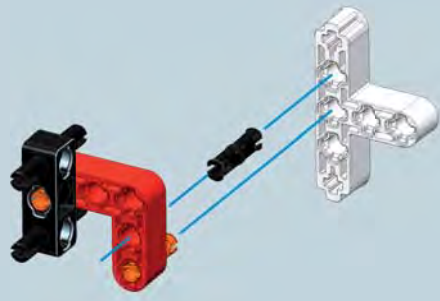
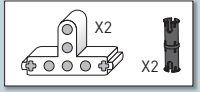

14

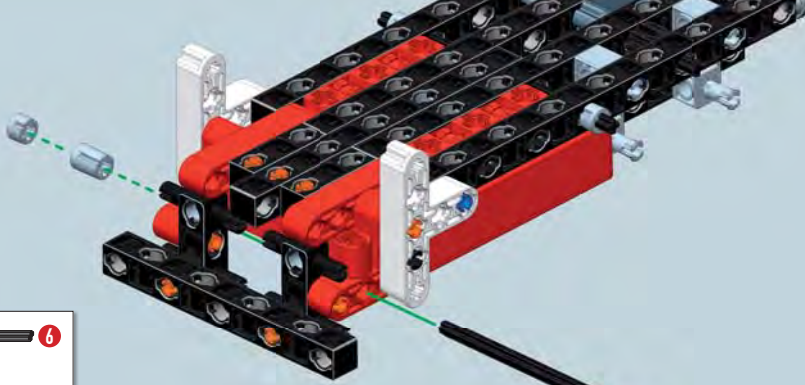

X1 6
 X2 X2

6

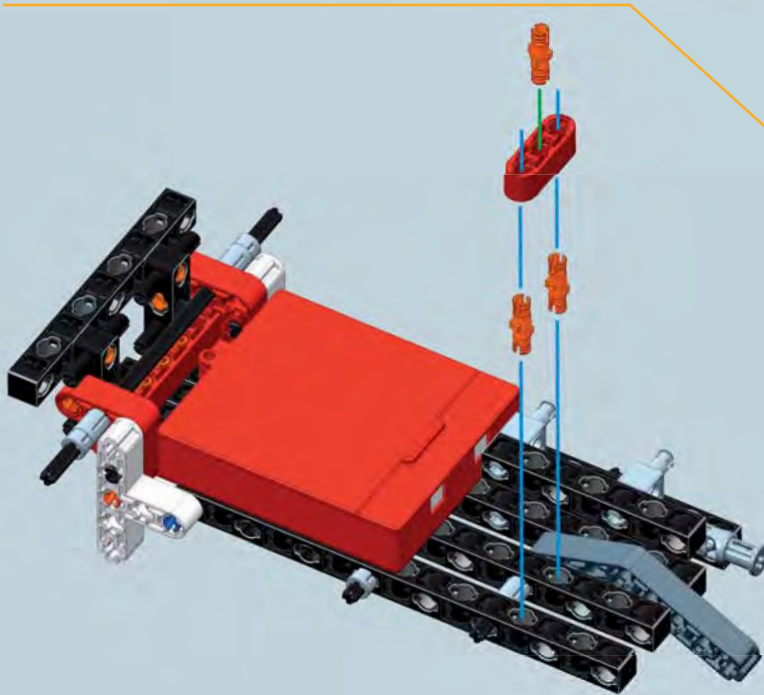

X1 X3

15

16

X1 X2

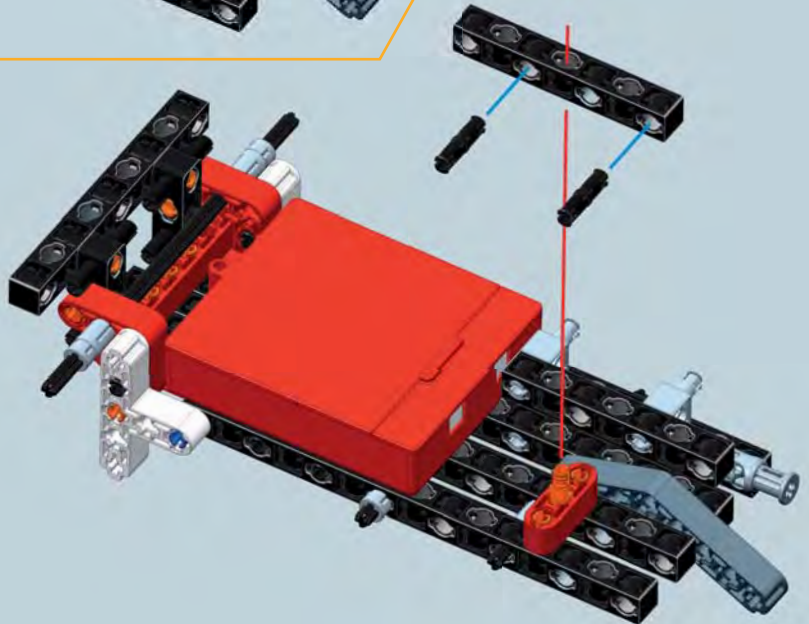

1:1

6

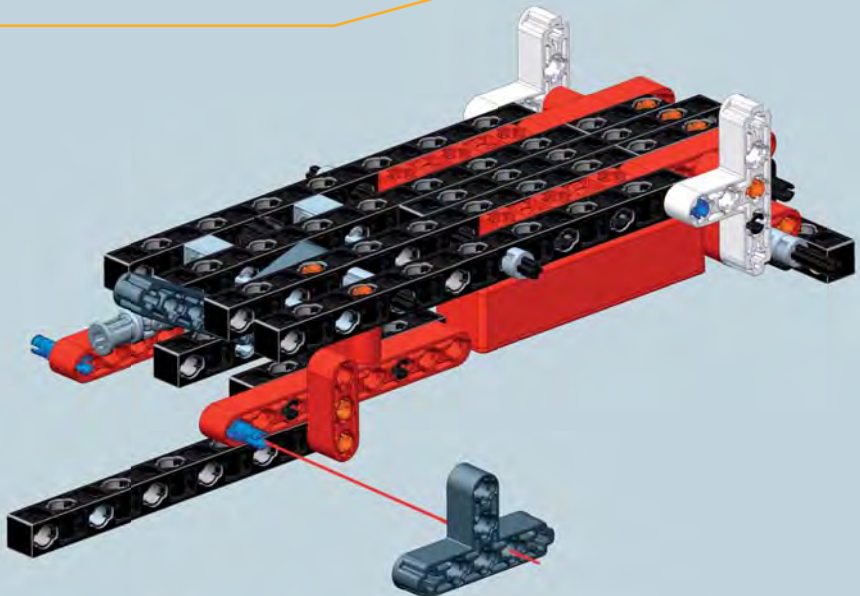
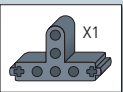
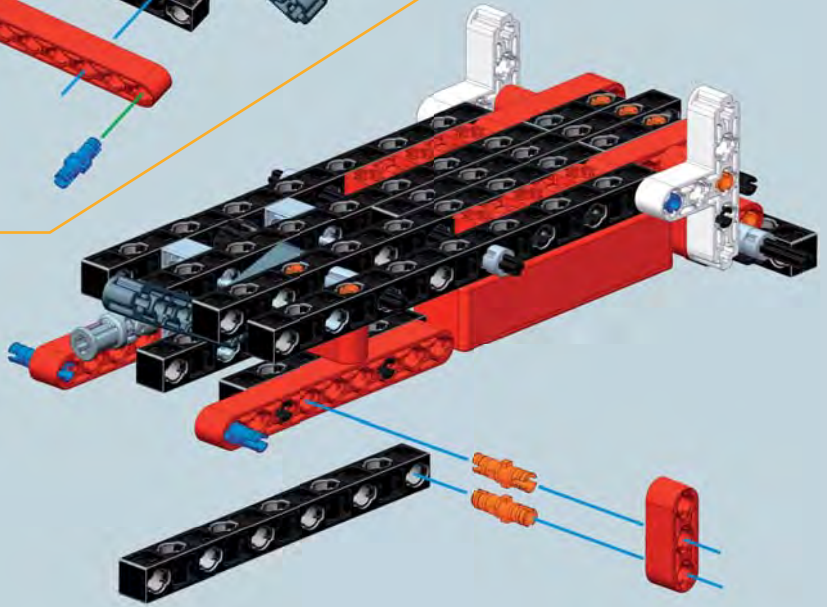
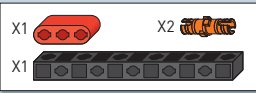
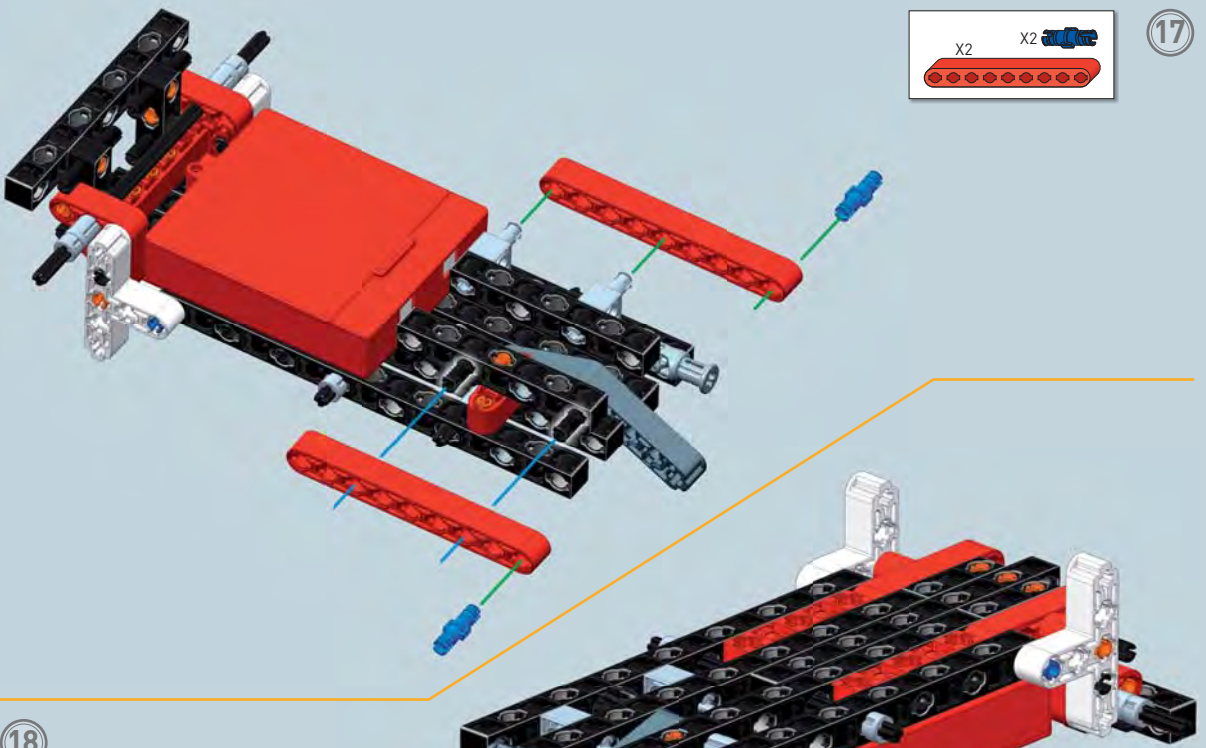
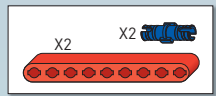

20

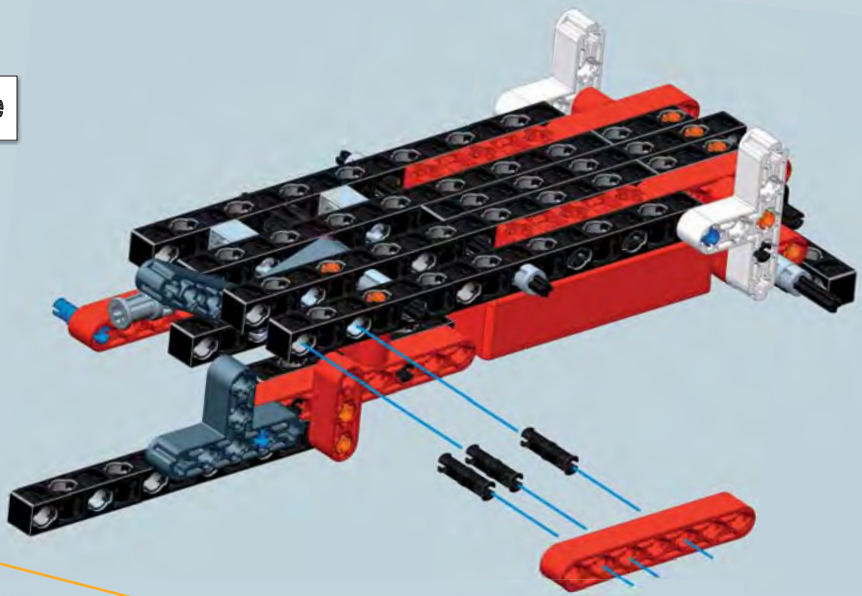

21

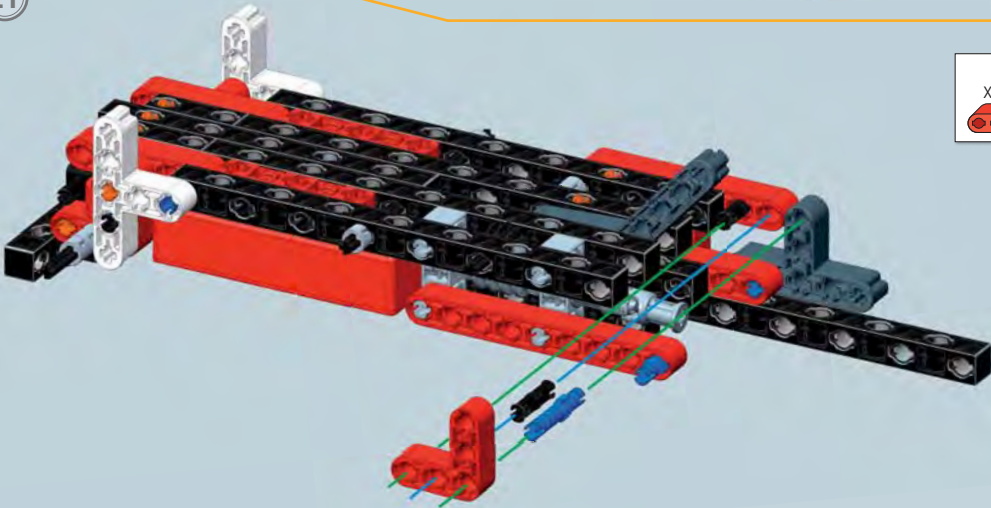
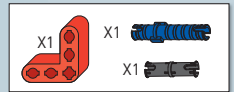

22

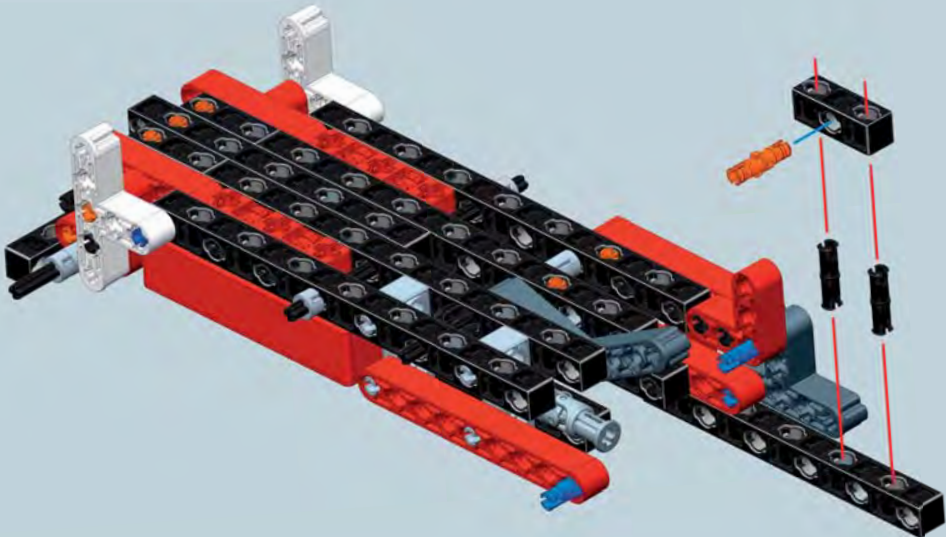
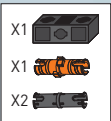

23

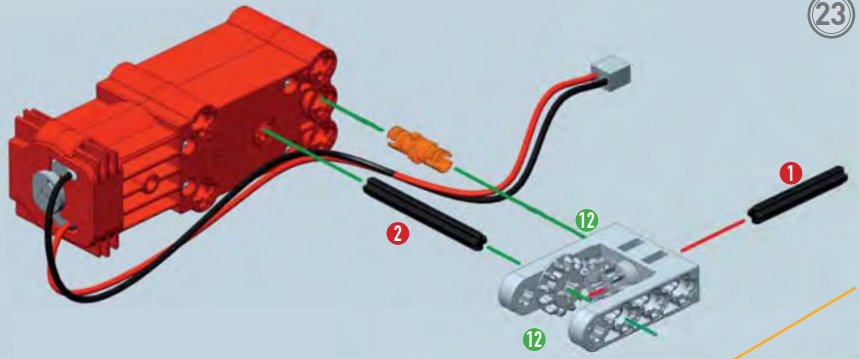
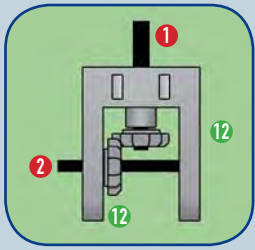
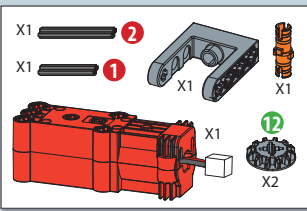

24

Connetti l'astina 1 al giunto cardanico

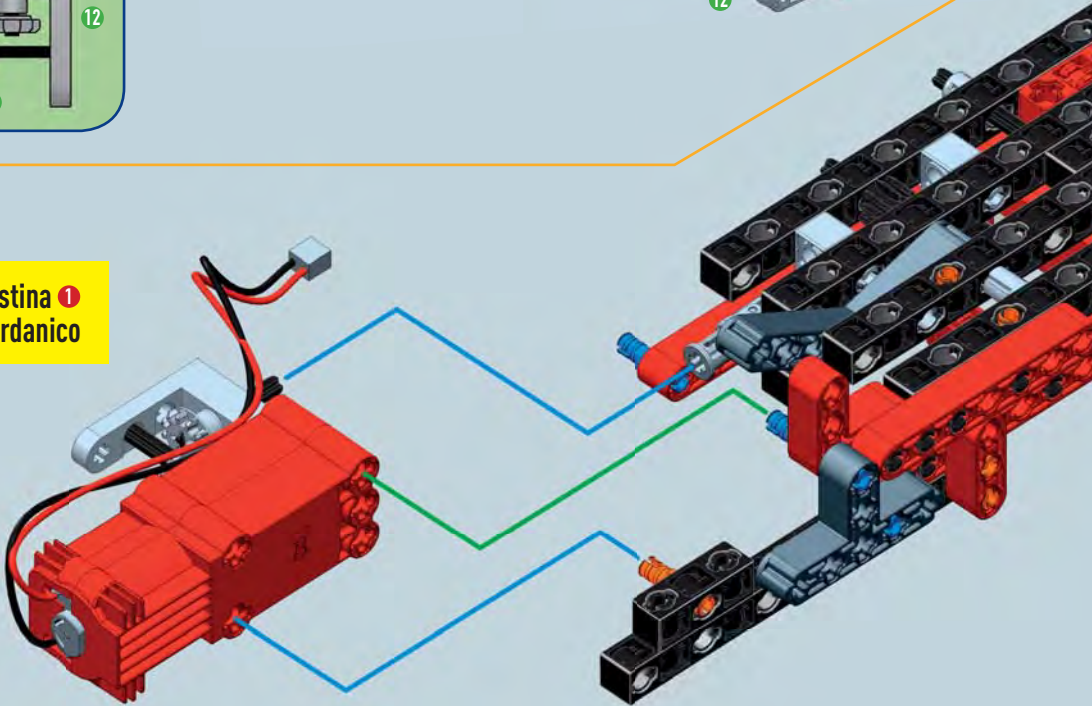

25

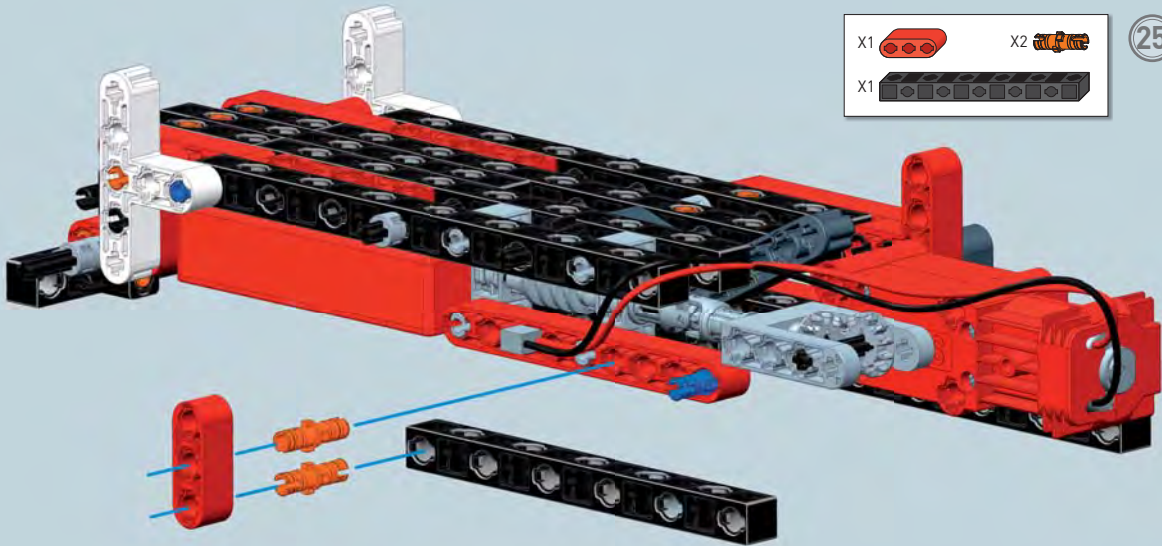

26

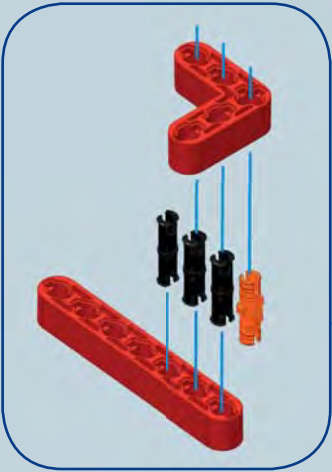
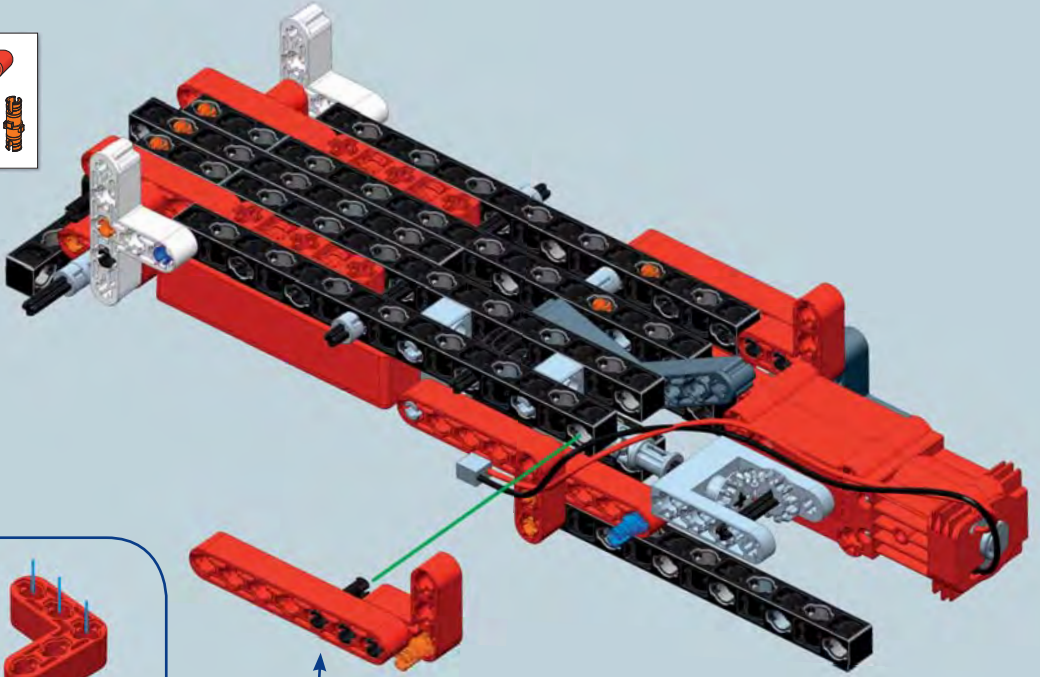
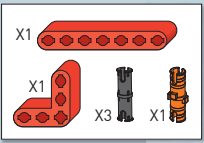

27

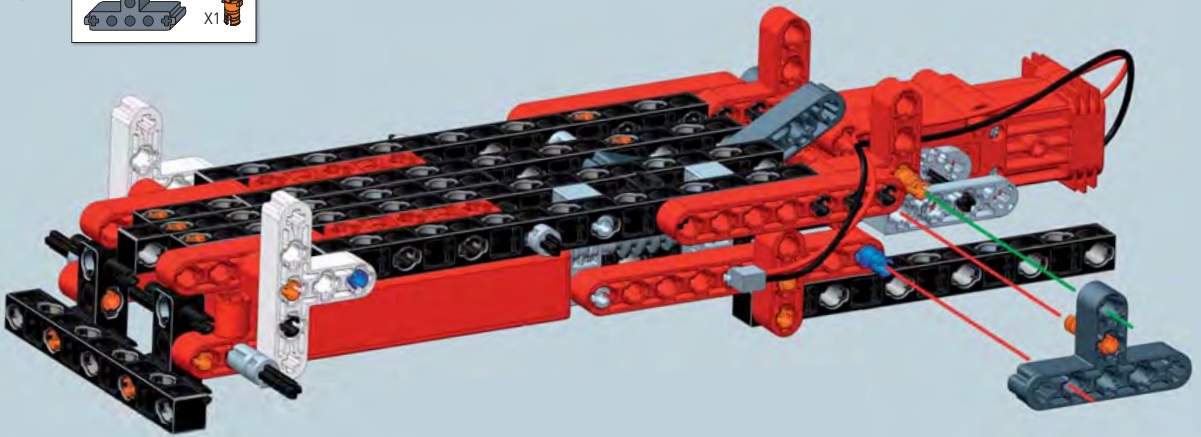
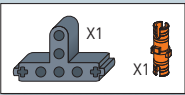

X1	X2	X1	6

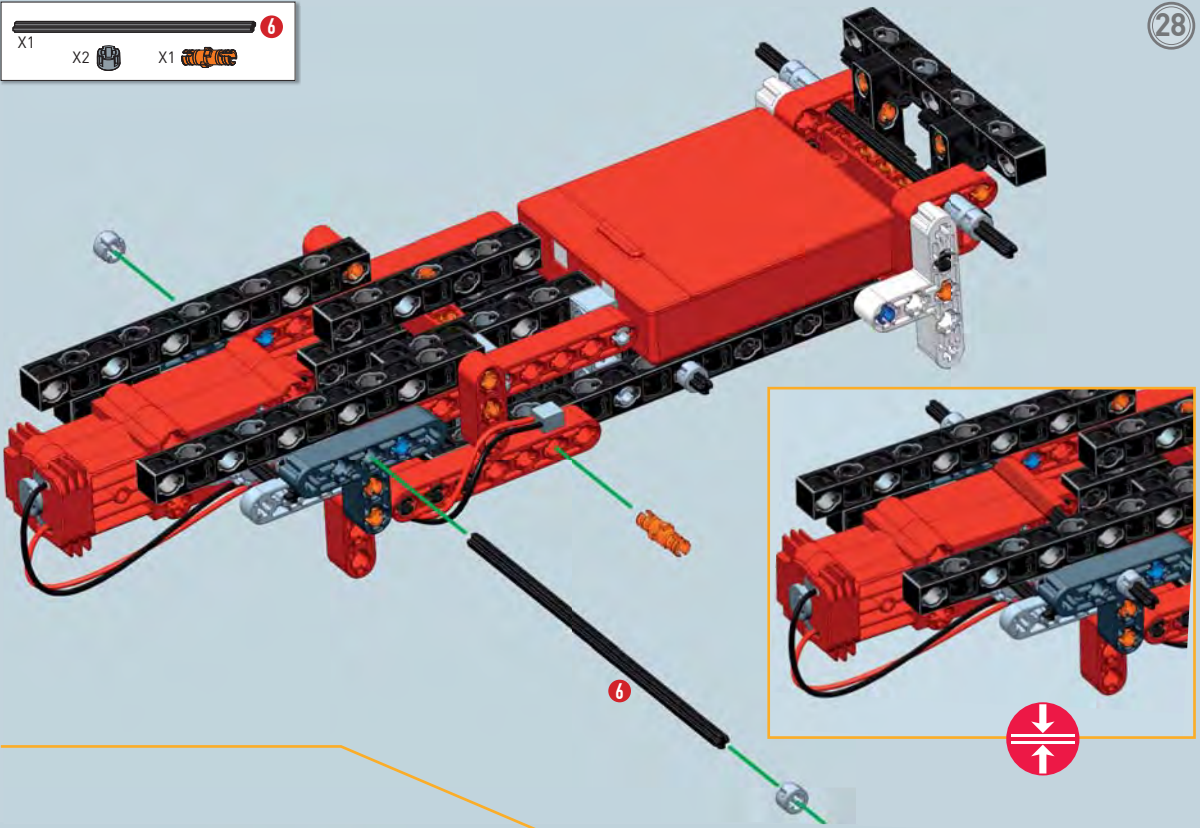
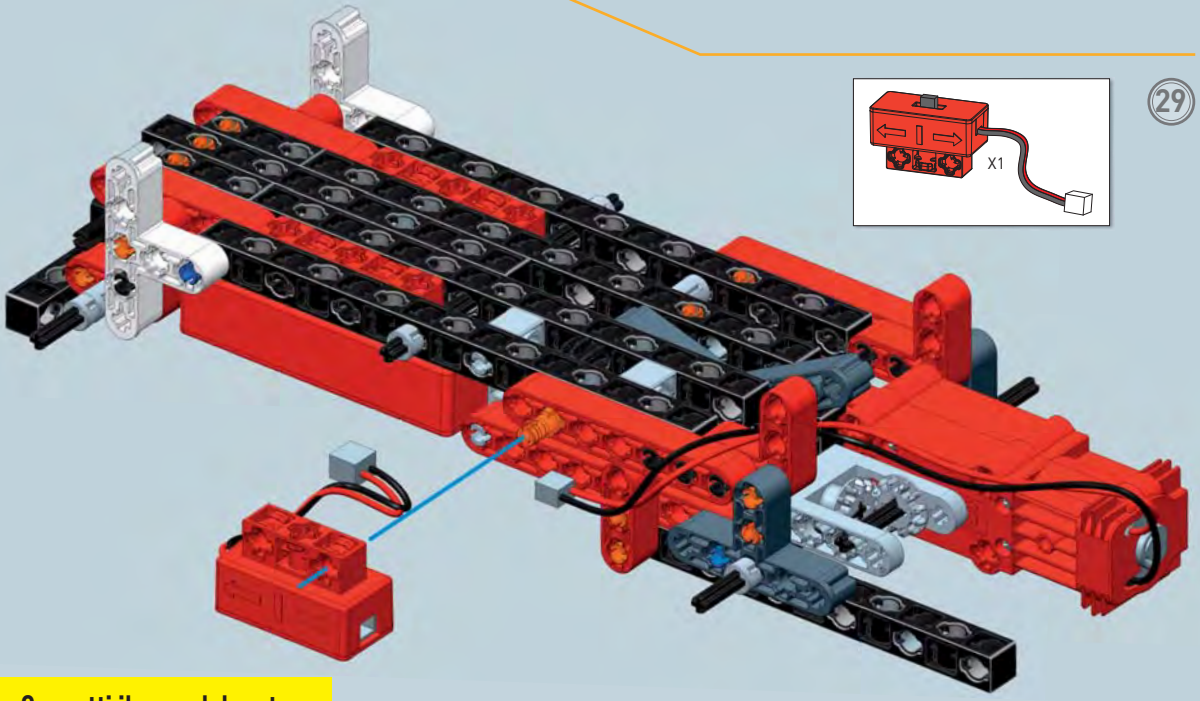
Connetti il cavo del motore allo switch e il cavo dello switch al vano batterie.

1:1	6
-----	---

30

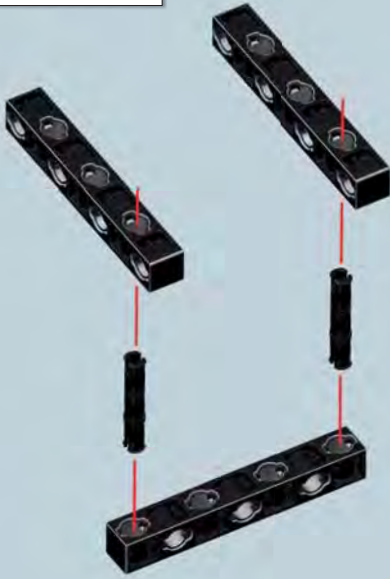
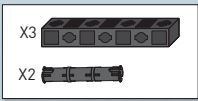

31

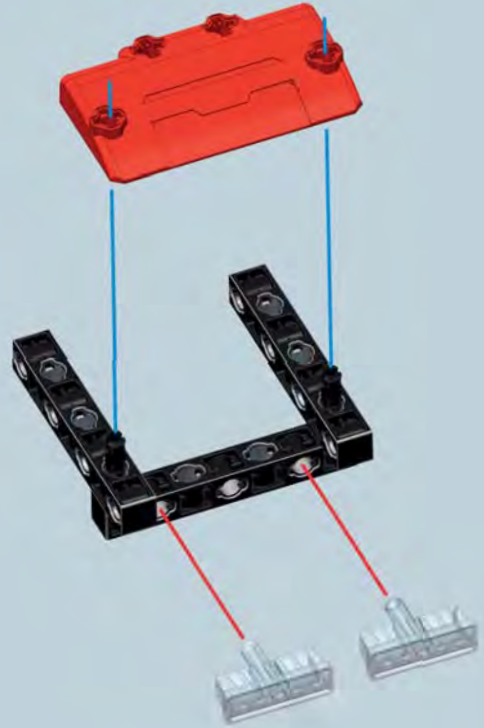

32

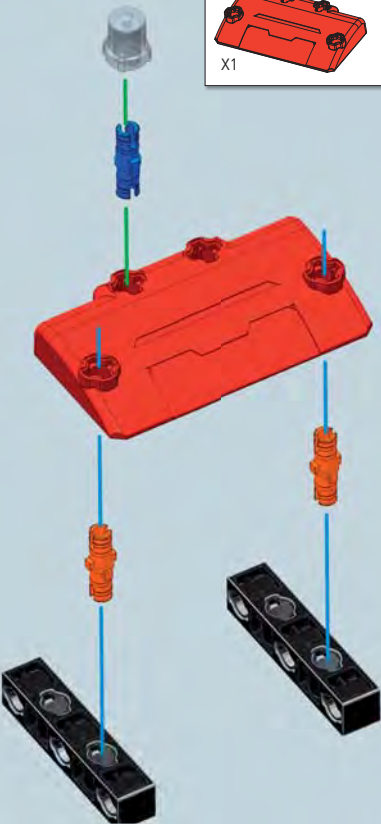
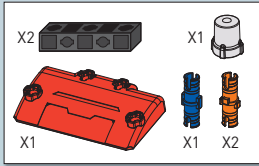

33

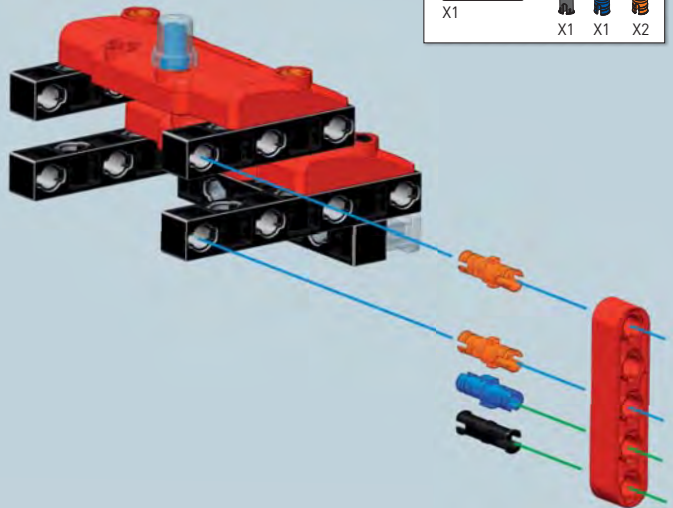
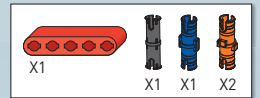

34

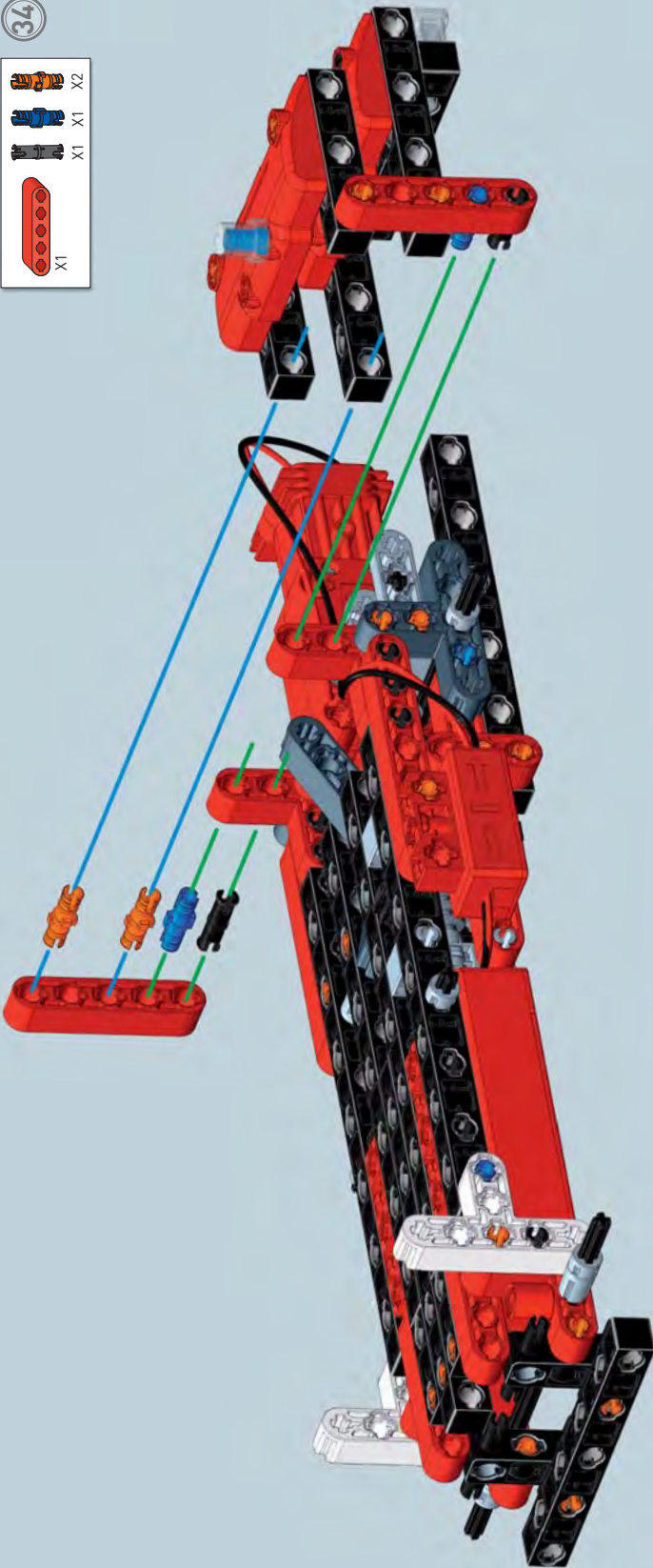

35

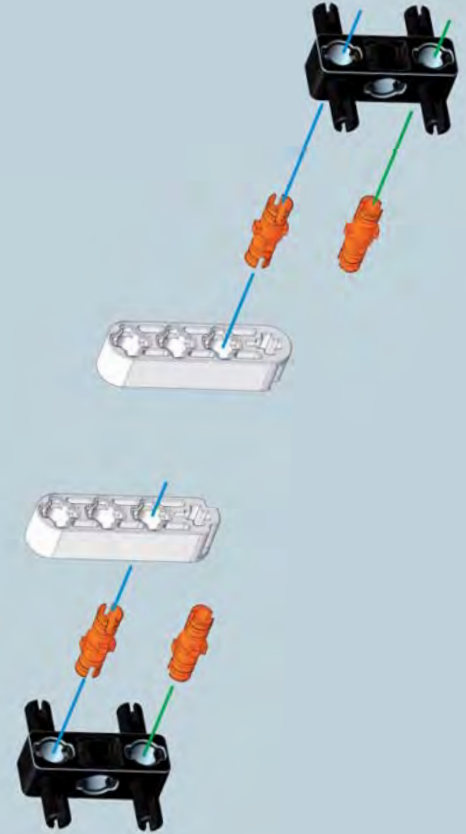
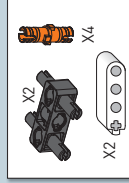

36

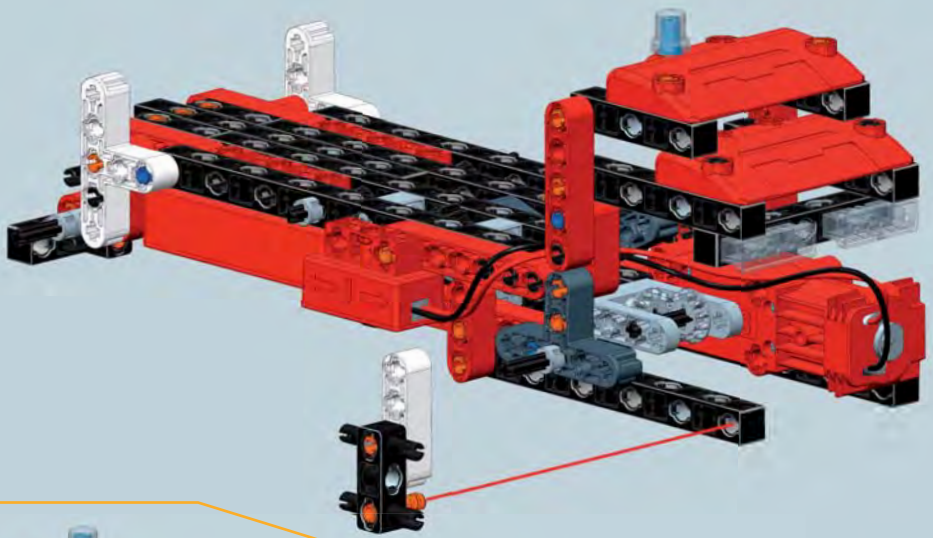

37

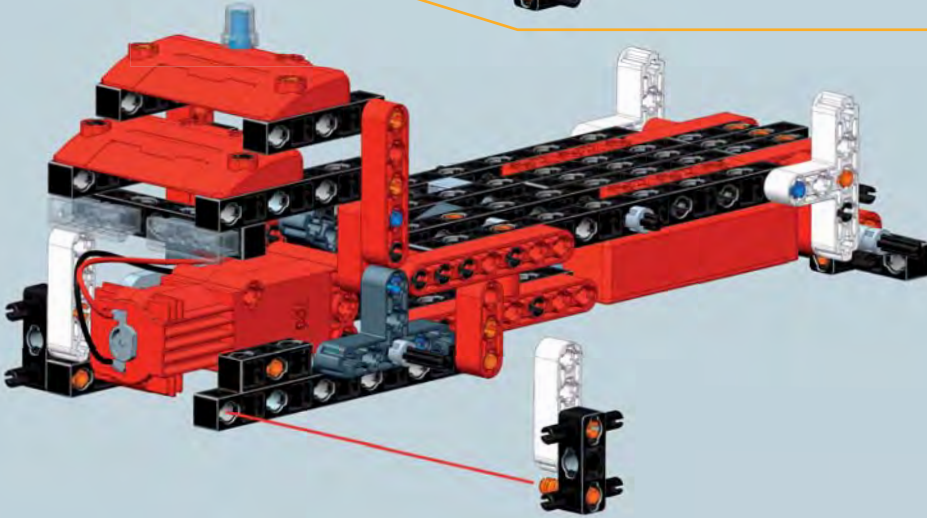

38

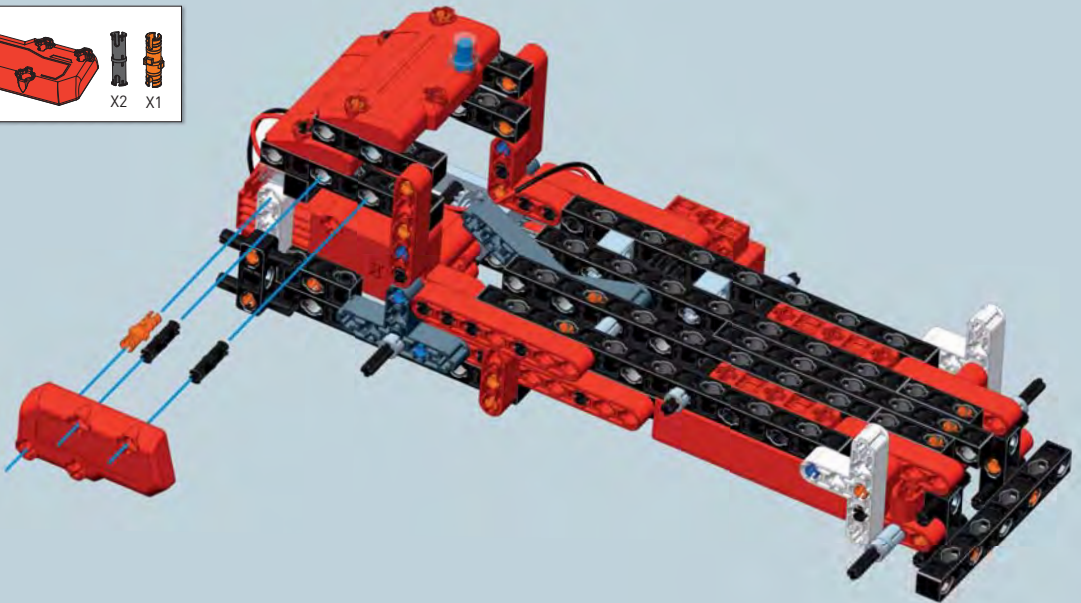
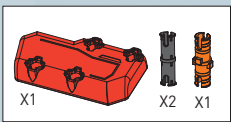

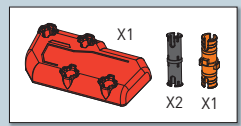
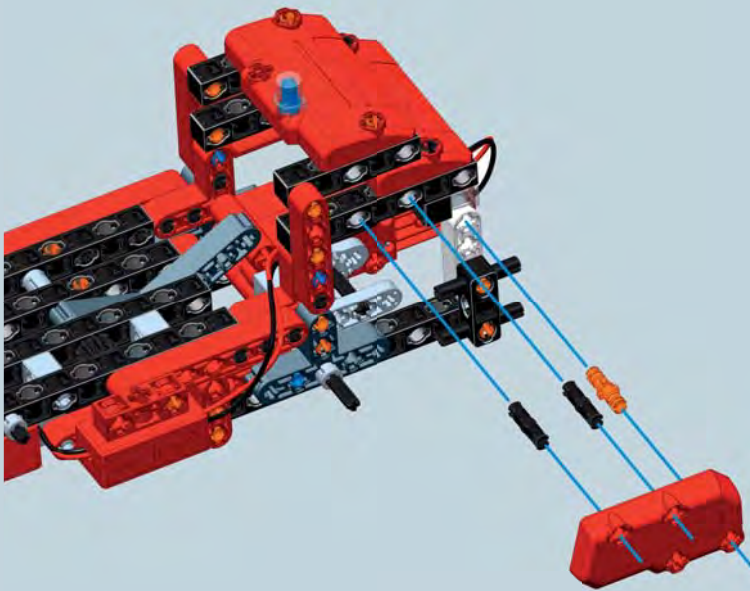

39

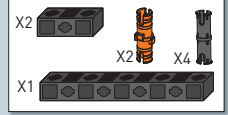
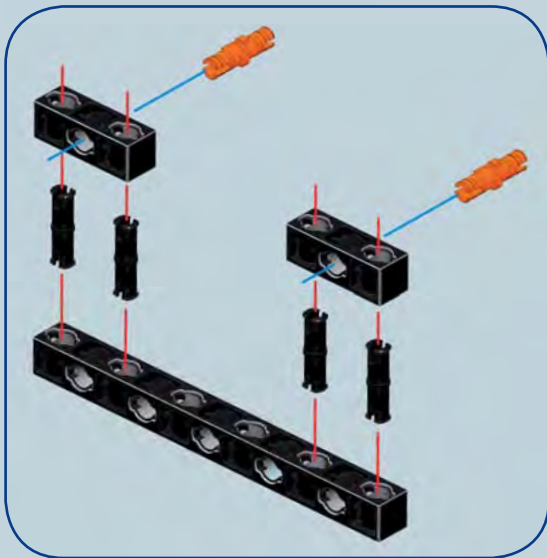

40

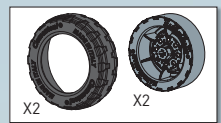
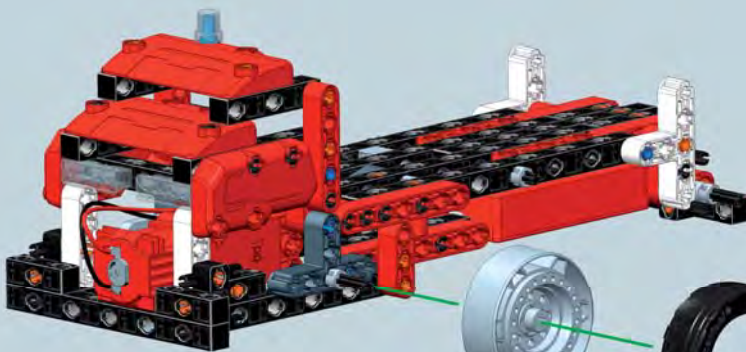
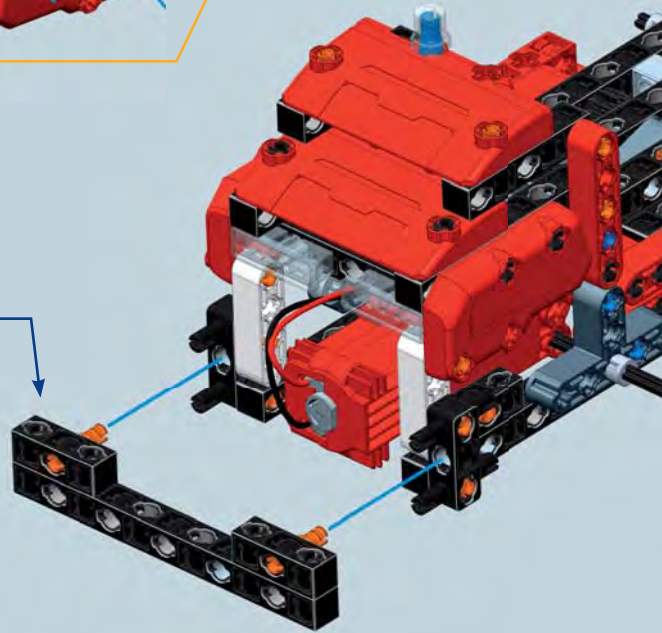

41

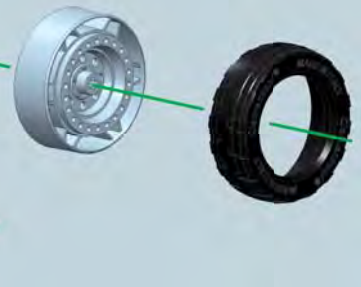

42

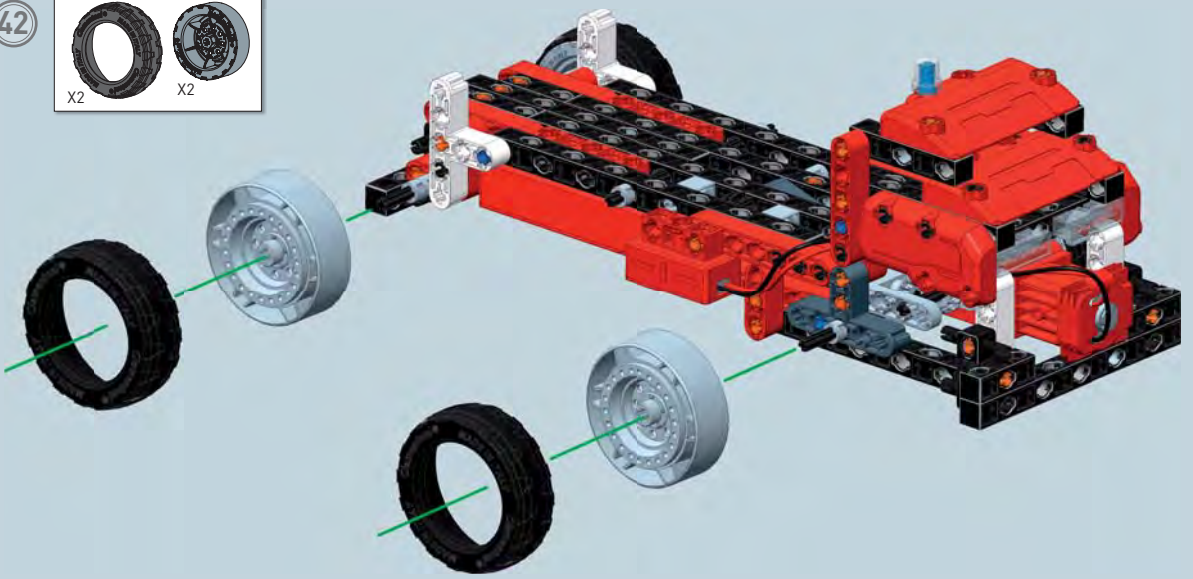
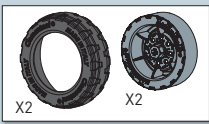

43

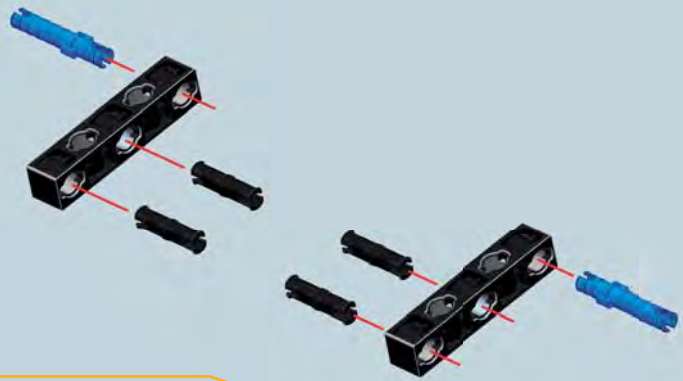
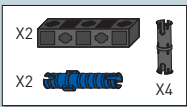

44

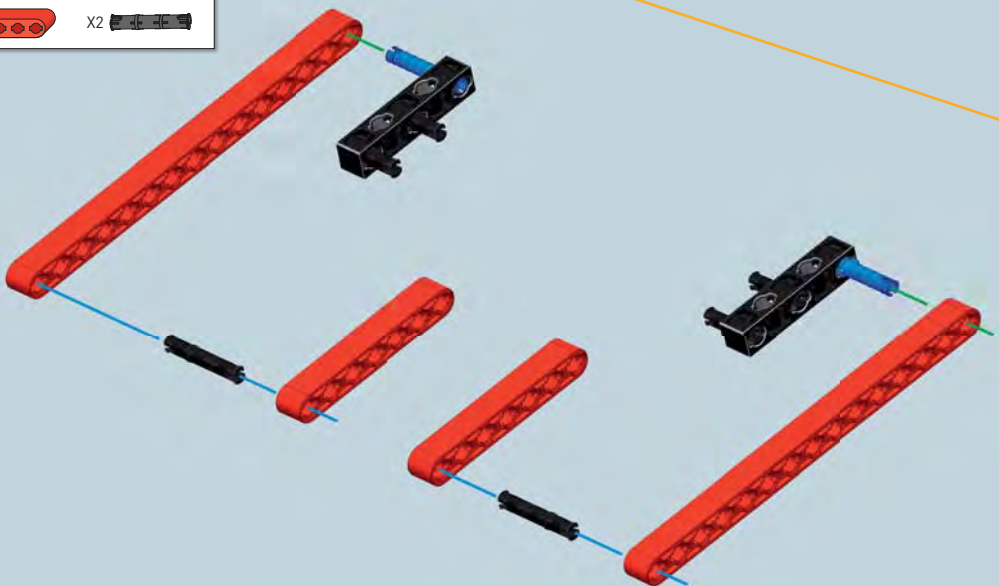
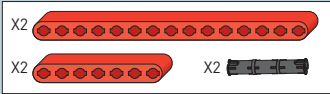

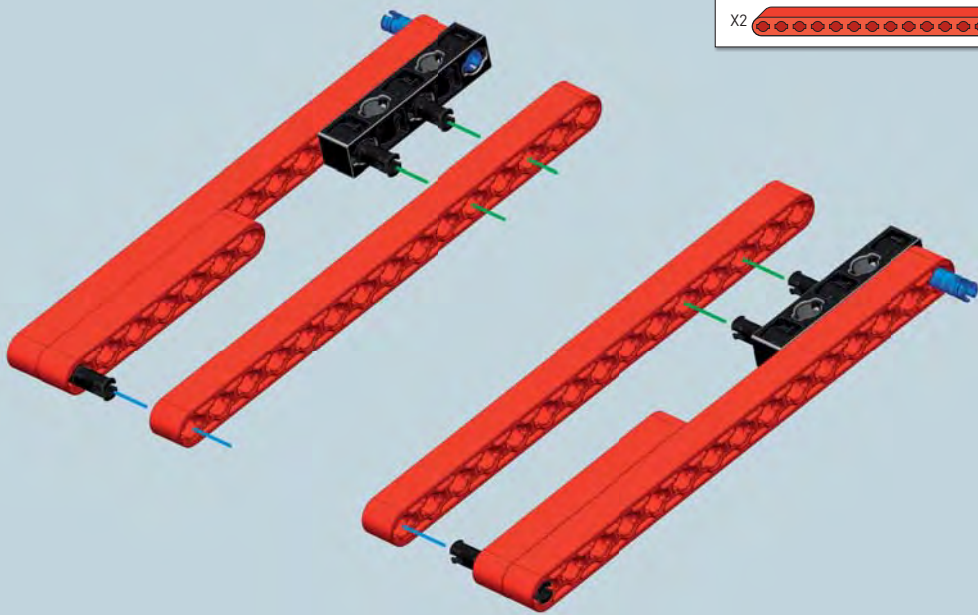

X2



45

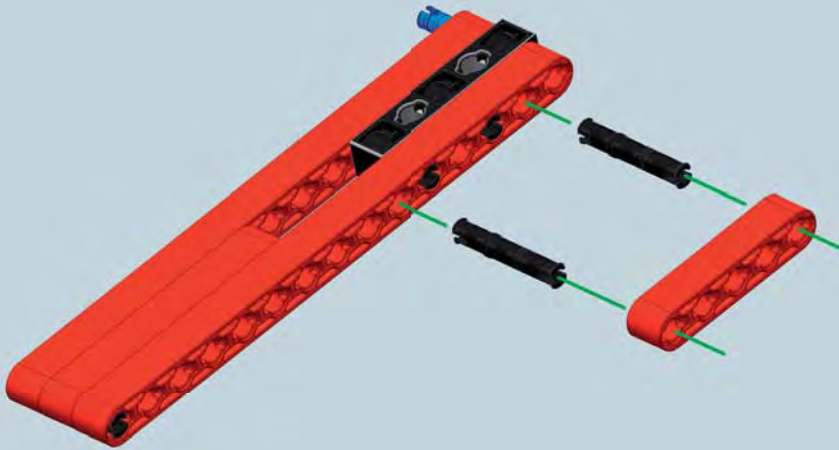

X2



X1



46

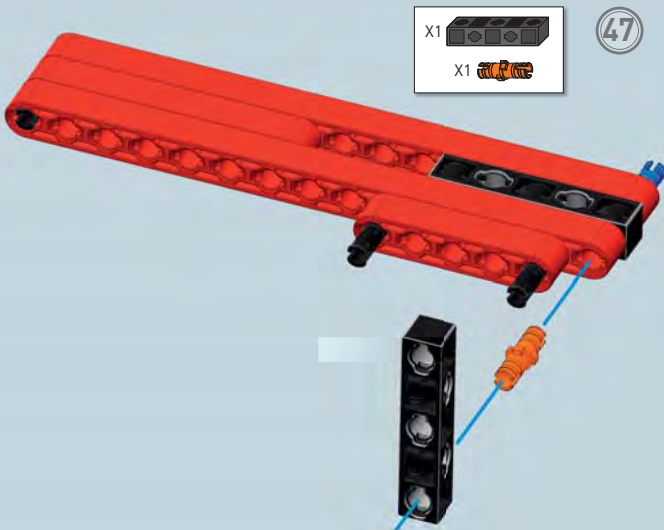

X1



X1

47

Notizie tecniche e curiosità

La maggior parte dei carri attrezzi è dotata di un piano di carico, fisso o inclinabile. Il piano inclinabile è azionato da cilindri idraulici che ne permettono il sollevamento e quindi l'inclinazione.



48

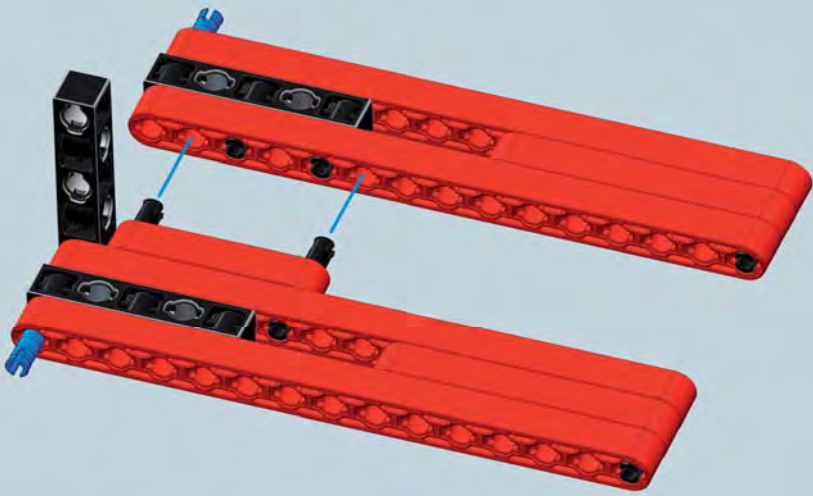

49

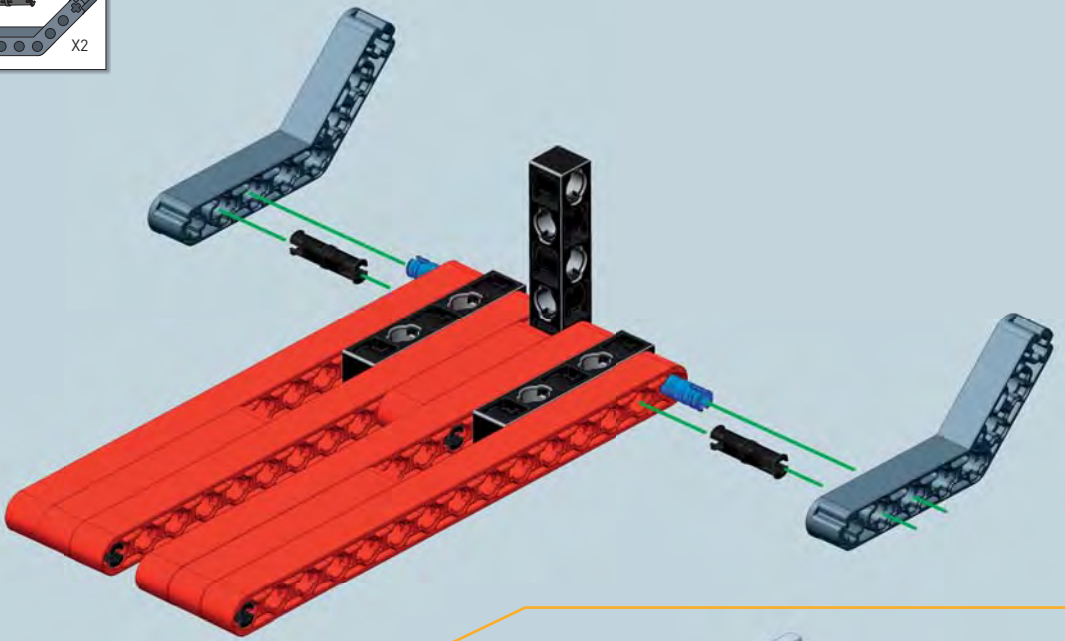
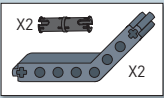

50

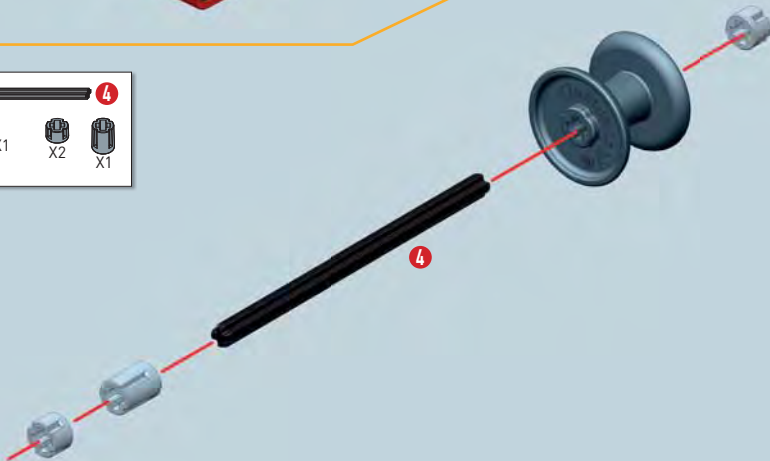
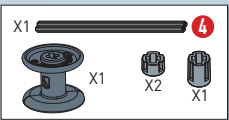

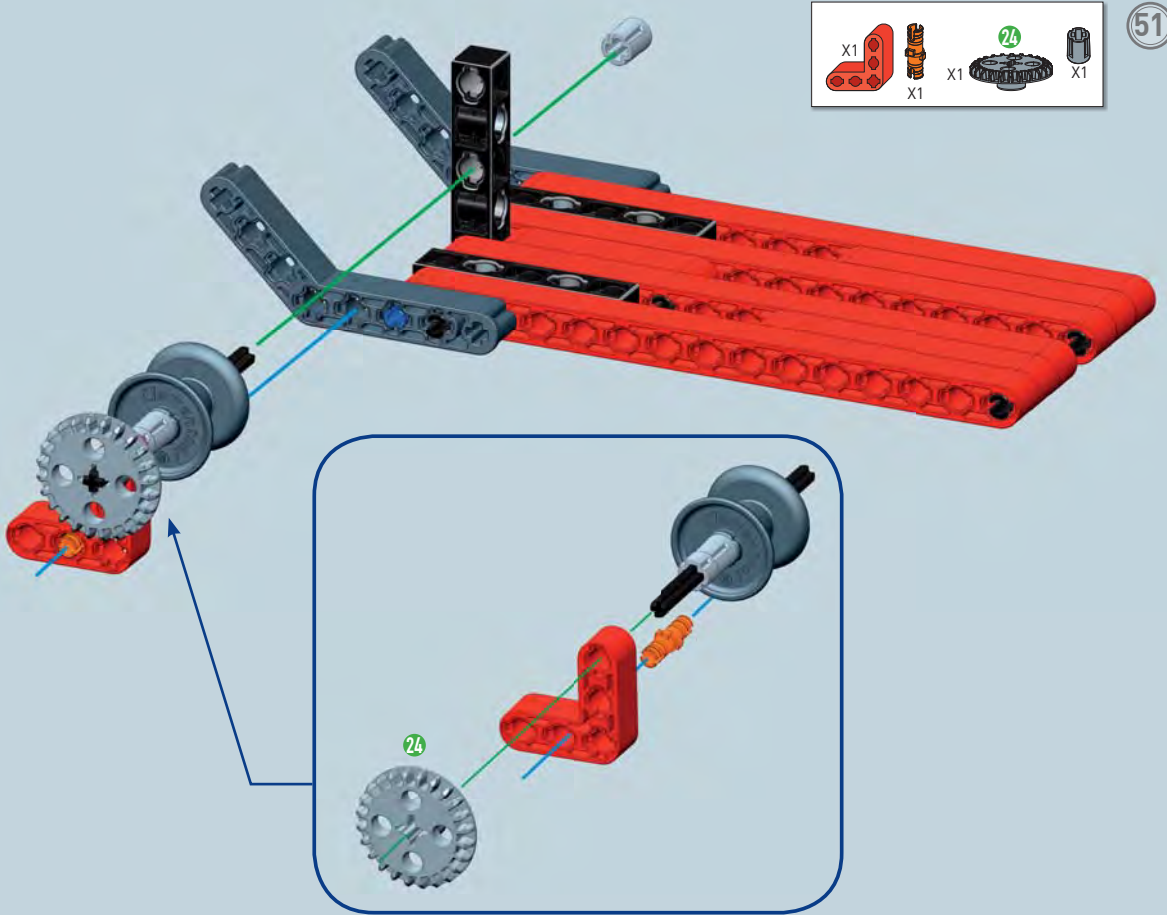

Notizie tecniche e curiosità

Il verricello è un elemento indispensabile per caricare il veicolo in difficoltà sui carri attrezzi. E' una macchina semplice utilizzata per il traino di oggetti pesanti. Grazie a potenti cavi in acciaio, i verricelli montati sui carro attrezzi hanno capacità di traino fino a 5500 kg circa.



- X1 5
- X5 X2

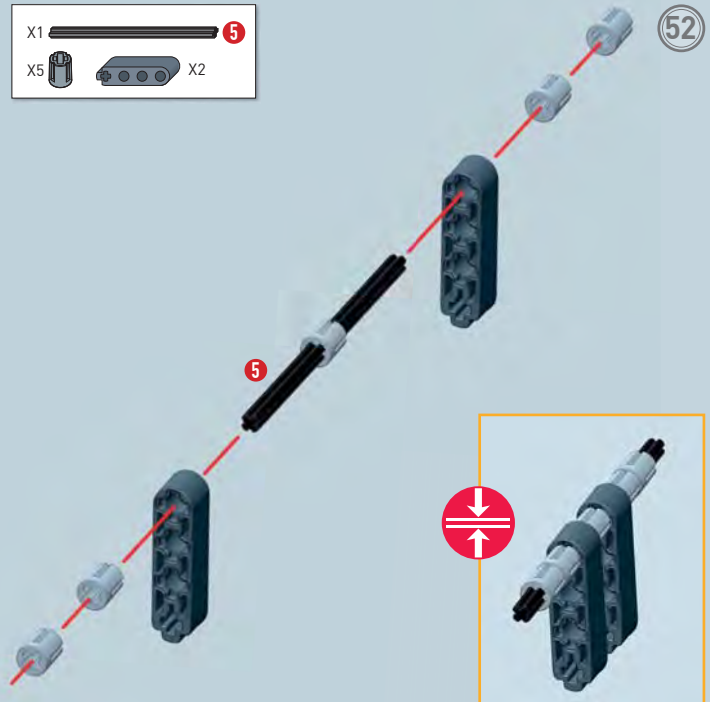

53

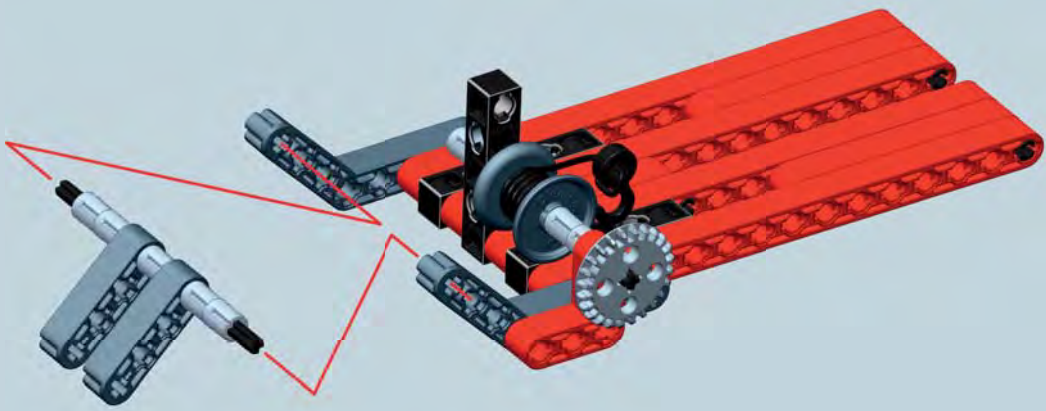

54

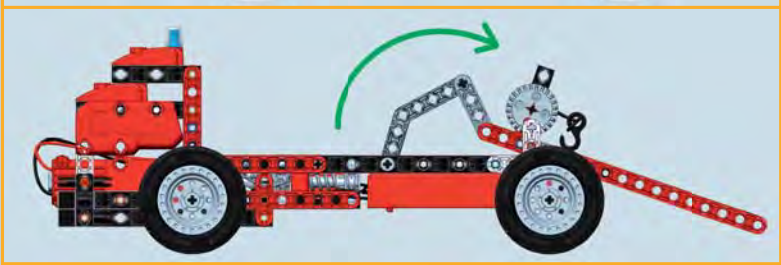
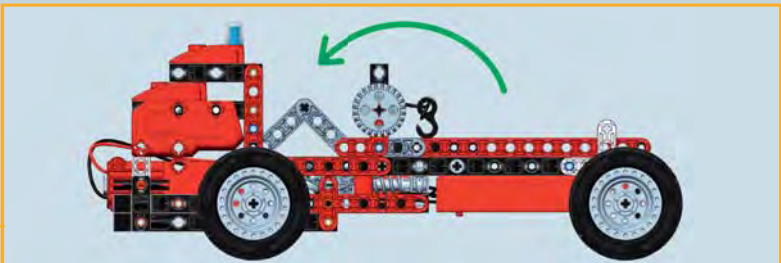

Usa lo switch per attivare il piano ribaltabile.

