

# Laboratorio di MECCANICA

## MEZZI DI SOCCORSO

Costruzioni da **4** a **5**

- 4 - Lo spazzaneve
- 5 - L'elicottero di soccorso

### AVVISO

Per garantire un adeguato funzionamento del motore elettrico, durante la produzione è stata aggiunta una piccola quantità di grasso. In presenza di temperature elevate tale sostanza può sciogliersi divenendo untuosa.

Nel caso in cui il motore contenuto nel kit sia sporco, puoi semplicemente pulirlo con delle salviette.

Il grasso utilizzato non è né tossico, né pericoloso.

### ATTENZIONE!

Solo per bambini di 8 anni e oltre.

Le istruzioni per gli adulti sono incluse e devono essere rispettate.

Manuale da leggere e conservare per future referenze.

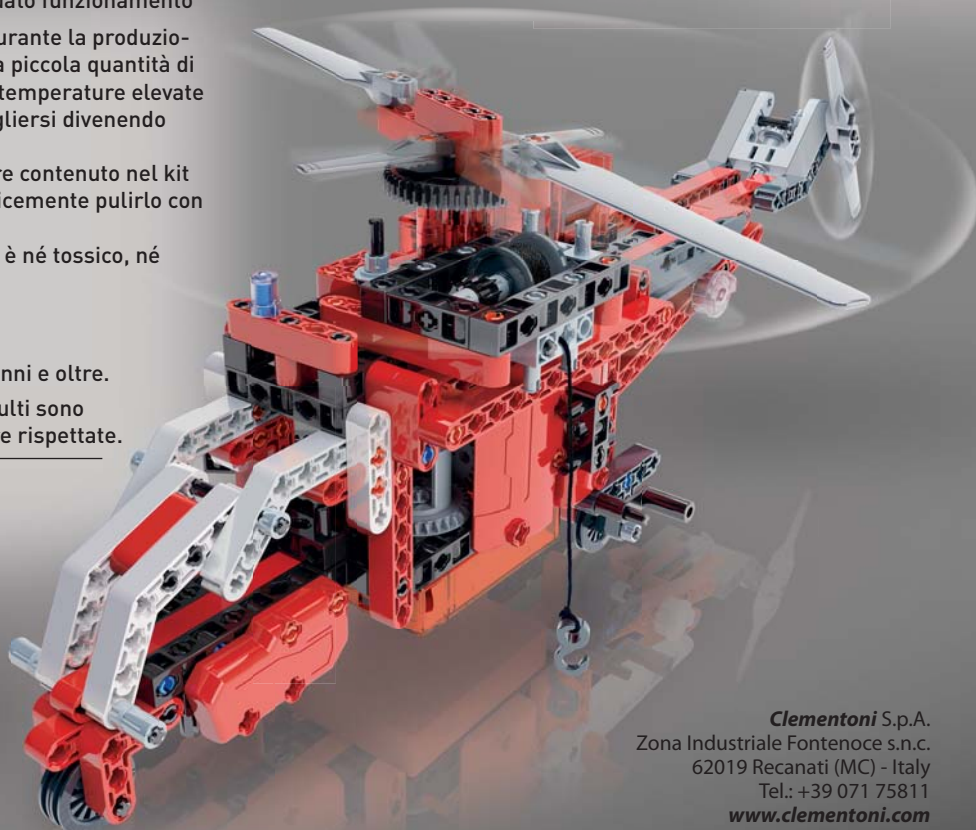

Clementoni S.p.A.  
Zona Industriale Fontenoce s.n.c.  
62019 Recanati (MC) - Italy  
Tel.: +39 071 75811  
[www.clementoni.com](http://www.clementoni.com)

V38494



Assistenza clienti

Tel. 02.82.52.52

Email - [assistenza@clementoni.it](mailto:assistenza@clementoni.it)





Con il termine spazzaneve, non si intende propriamente un veicolo, quanto un'apparecchiatura montata su di un veicolo e utilizzata per la rimozione della neve e del ghiaccio dalla superficie stradale.

Lo strumento che rende tale uno spazzaneve è la lastra di acciaio sagomata, che può essere montata non solo su camion, ma anche su normali mezzi fuoristrada e addirittura su treni, per lo sgombero della neve dai binari.



1

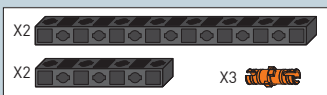
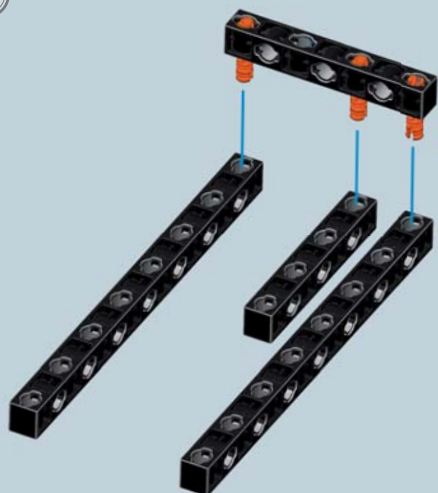

2

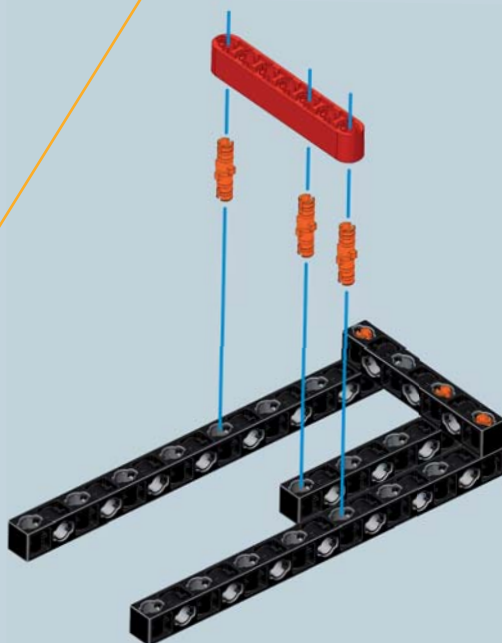
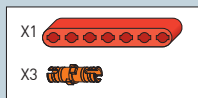

3

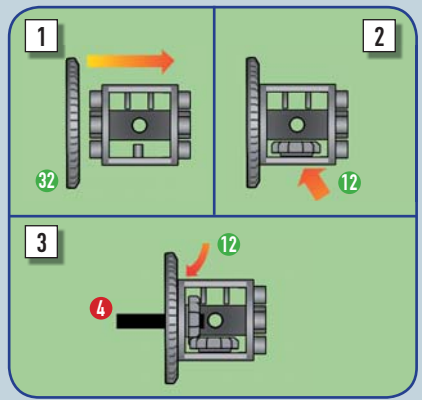
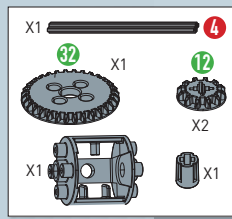
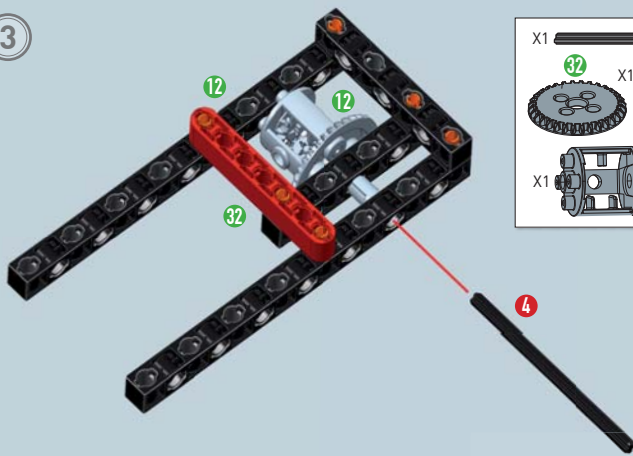

4

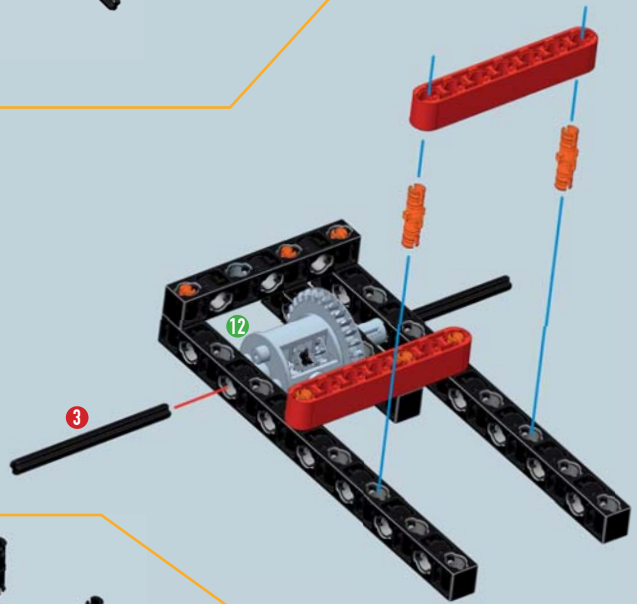
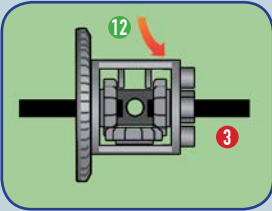
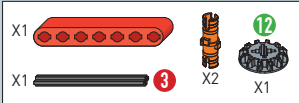

5

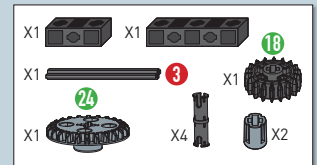
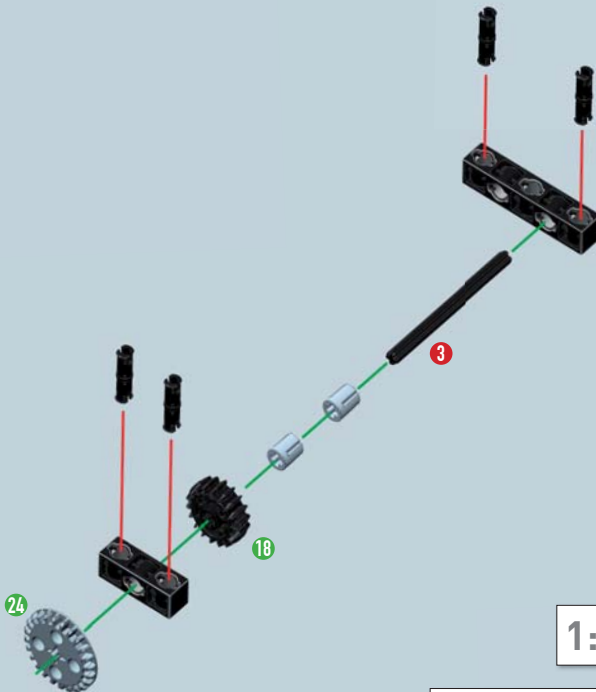



La base del telaio che hai appena costruito, monta un differenziale completo di pignone, che ci permetterà in seguito di trasferire il movimento dal motore elettrico alle ruote.

In meccanica, il differenziale è un organo in grado di trasferire la potenza sviluppata dal motore, alla coppia di ruote motrici.



- 1 - **Pignone**: trasferisce potenza dal motore alla corona e in ultimo alle ruote motrici.
- 2 - **Corona**: vincolata alla gabbia porta satelliti, è accoppiata stabilmente al pignone.
- 3 - **Gabbia porta satelliti**: è la scatola che racchiude gli ingranaggi.
- 4 - **Satelliti**: ingranaggi vincolati alla gabbia.
- 5 - **Planetari**: ingranaggi vincolati ai semiassi.
- 6 - **Semiassi**: asse che collega le ruote motrici ai planetari.

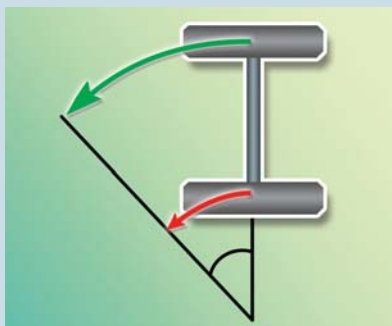

È progettato in modo da consentire alle due ruote di girare a velocità differenti in curva: nei tratti non rettilinei infatti, la ruota esterna alla curva percorre più strada rispetto a quella interna.

Grazie al differenziale, la ruota interna, che percorre una distanza minore, viaggia a una velocità inferiore; quella esterna, che percorre una distanza maggiore, viaggia a una velocità superiore.

## IL DIFFERENZIALE AUTOBLOCCANTE

Nei mezzi fuoristrada, viene montato un differenziale autobloccante. L'azione del differenziale può risultare infatti svantaggiosa se una delle due ruote perde aderenza: in questo caso, la ruota con maggior presa tenderebbe a rimanere ferma mentre l'altra slitta. Grazie a dei meccanismi controllati elettronicamente, il differenziale autobloccante permette di distribuire equamente la potenza del motore alle due ruote, aumentando quindi la forza motrice in situazioni di scarsa aderenza.

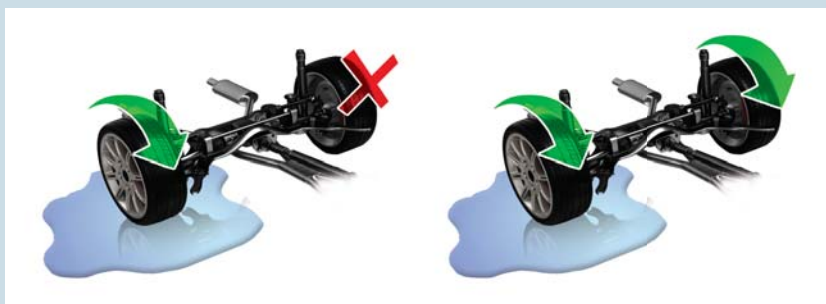

6

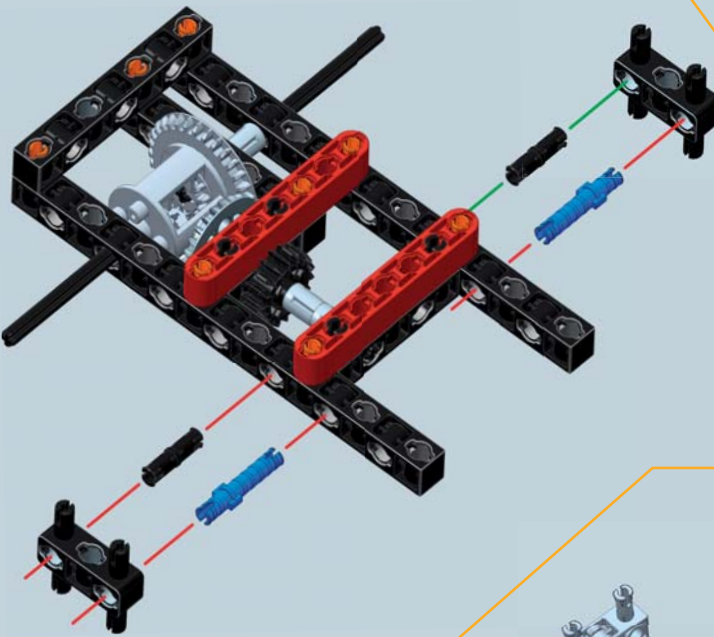
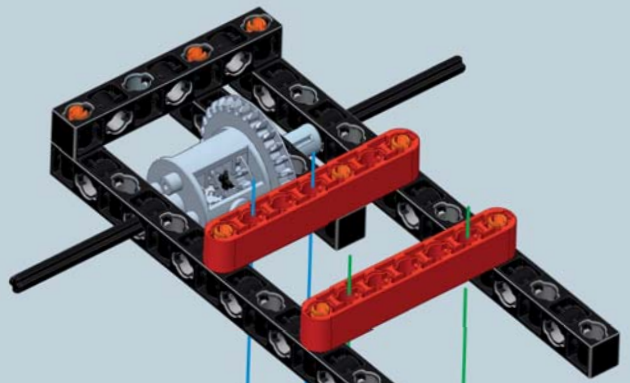
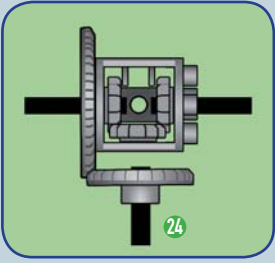

7

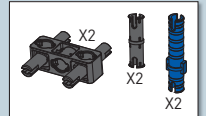

8

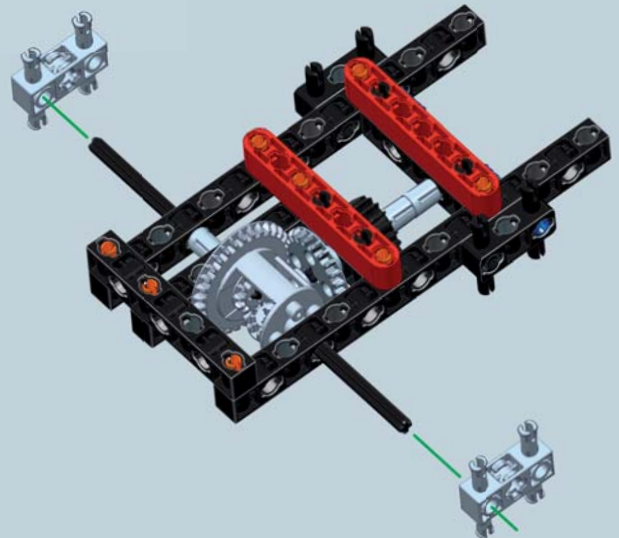
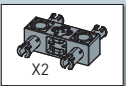

9

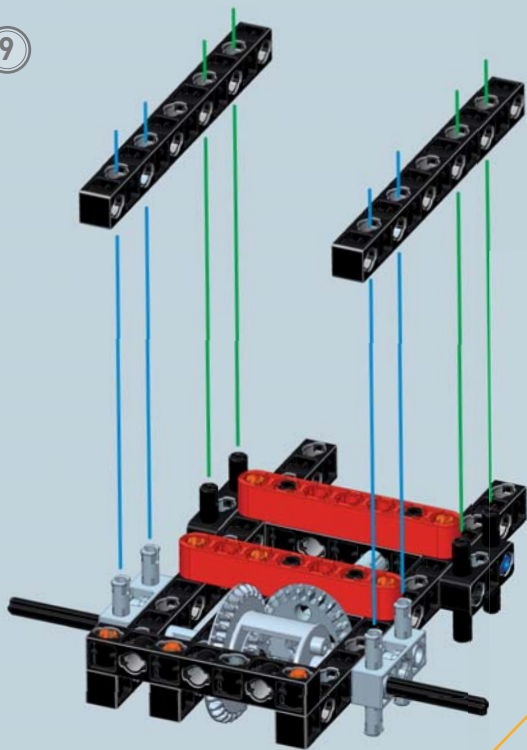

10

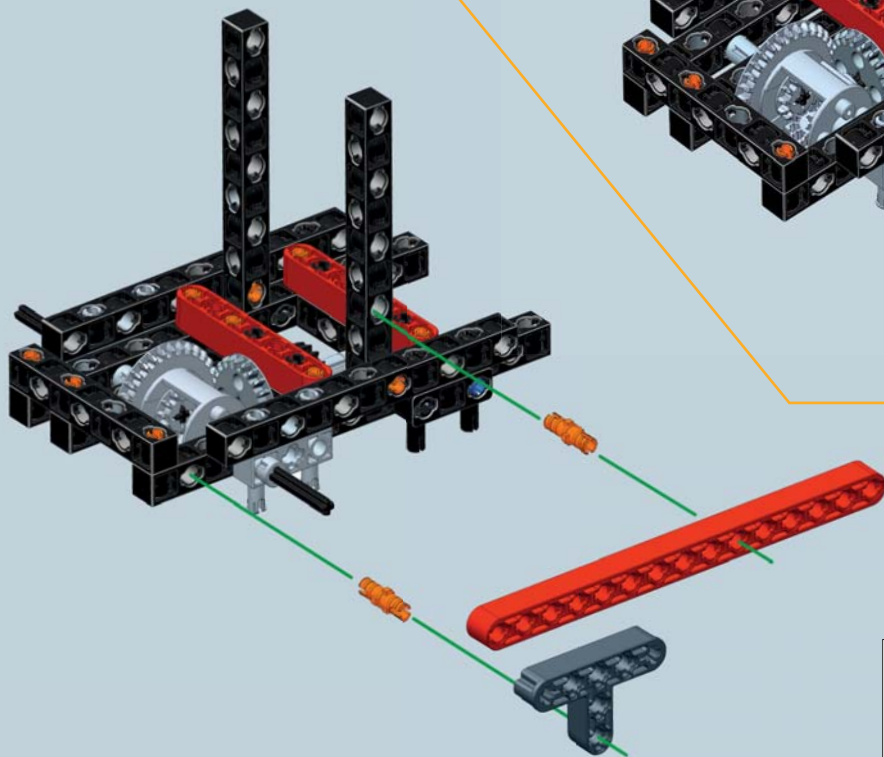
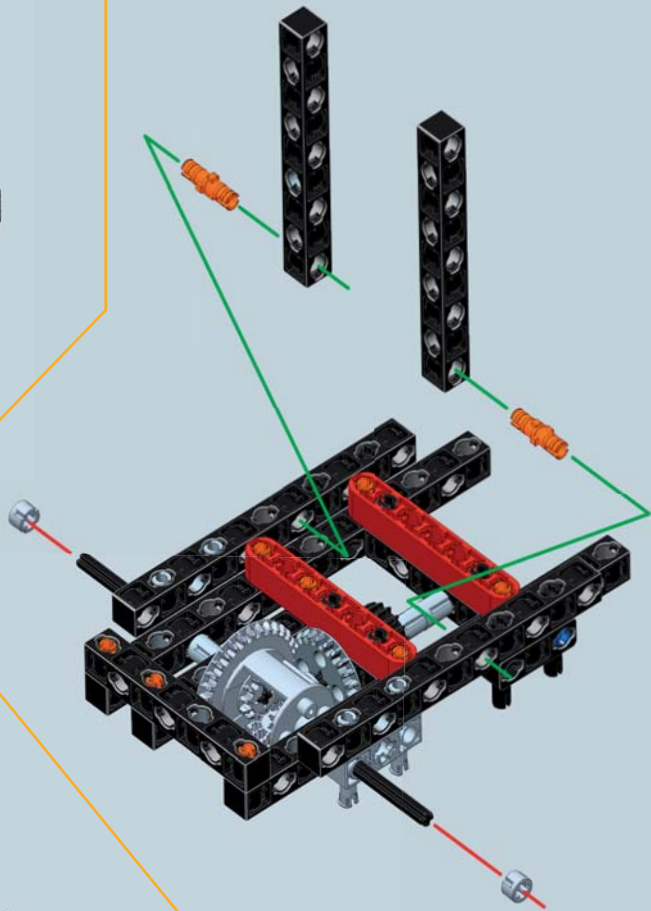
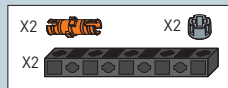

11

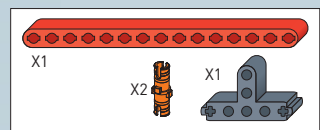

12

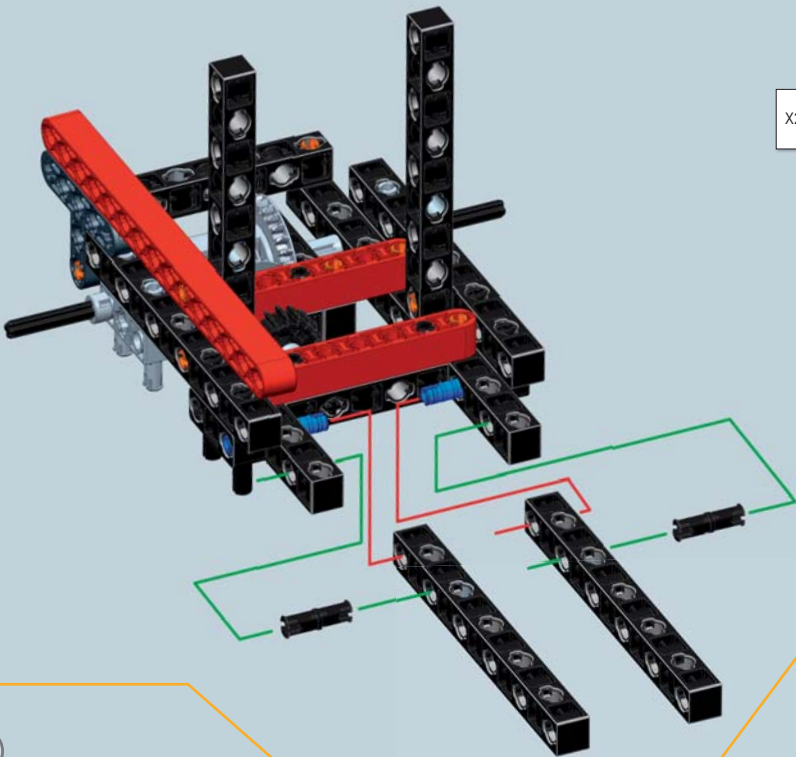

14

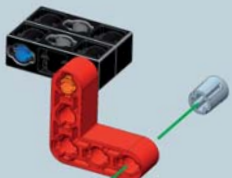

13

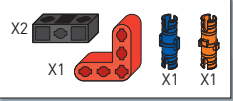
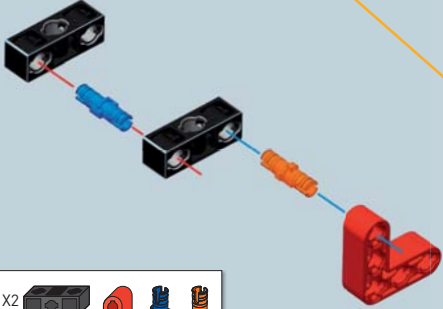

6

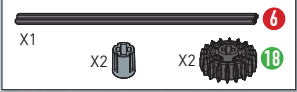
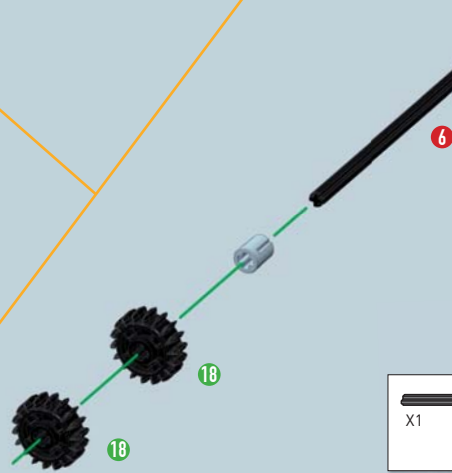

1:1



15

Appoggia il blocco costruito in precedenza sul telaio.

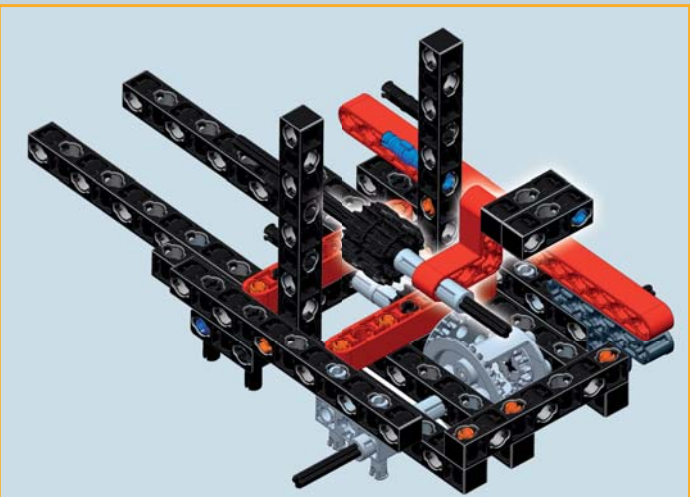
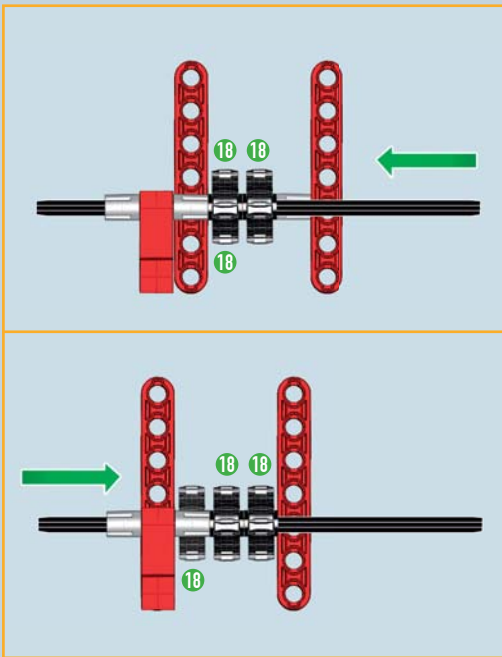
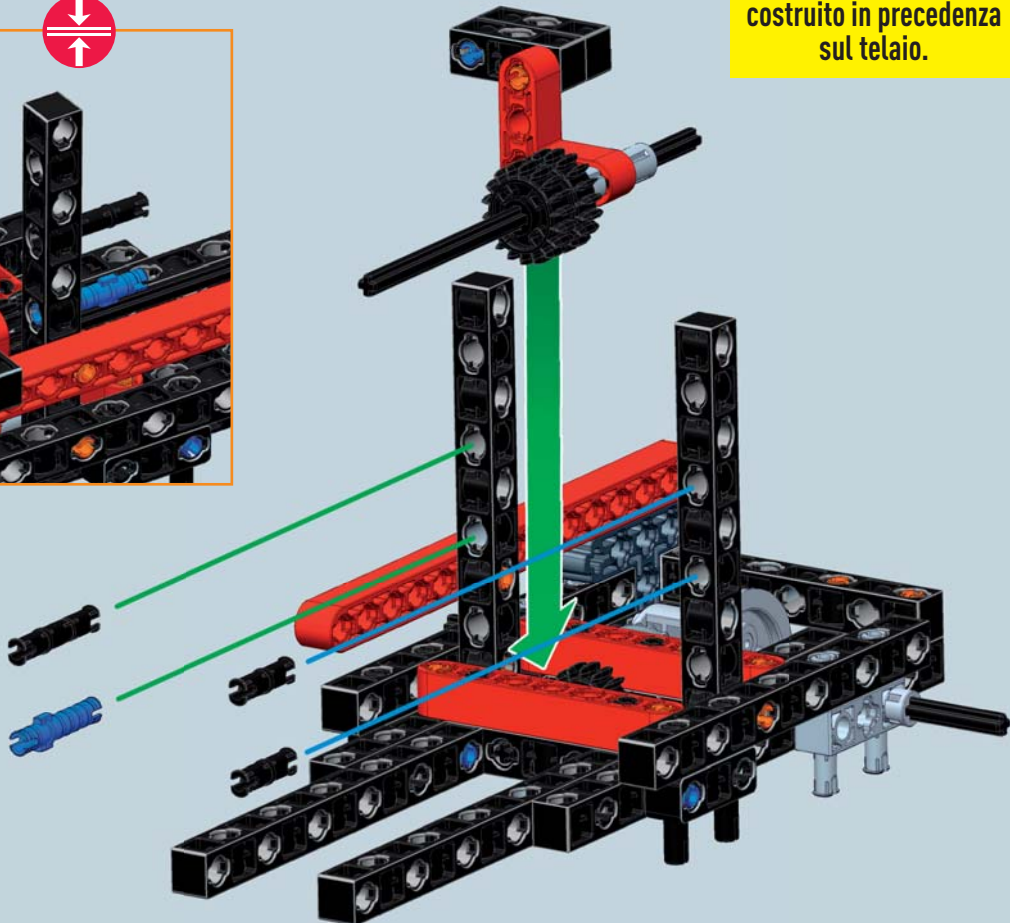
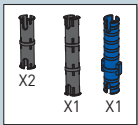
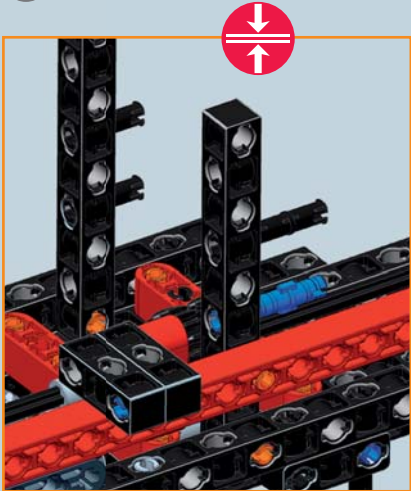

Verifica che le 2 ruote dentate da 18 siano ben sistemate tra le due barre singolo foro, e allineate con l'altra ruota dentata da 18 posta sotto. Il sistema di scambio verrà fissato nei passaggi seguenti.



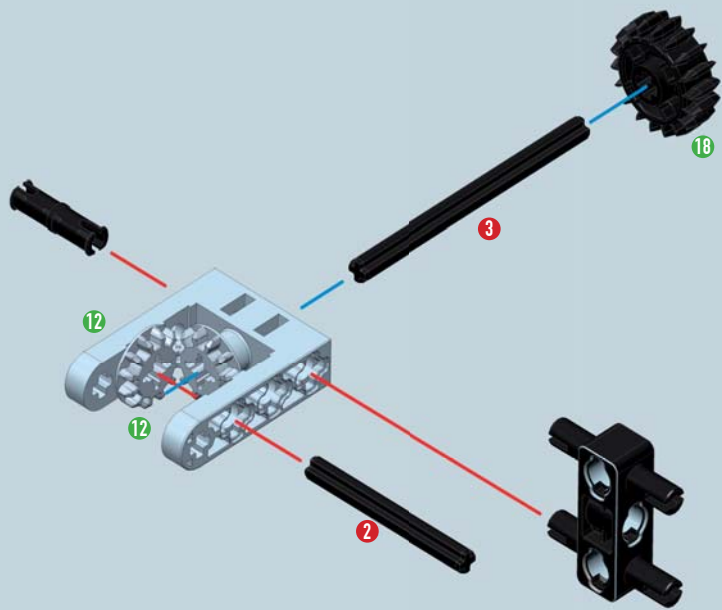
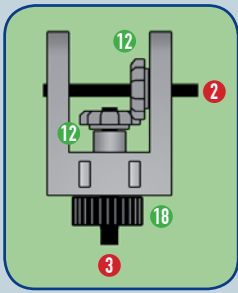

- X1
- X1 X1
- X1
- X1
- X1 X2

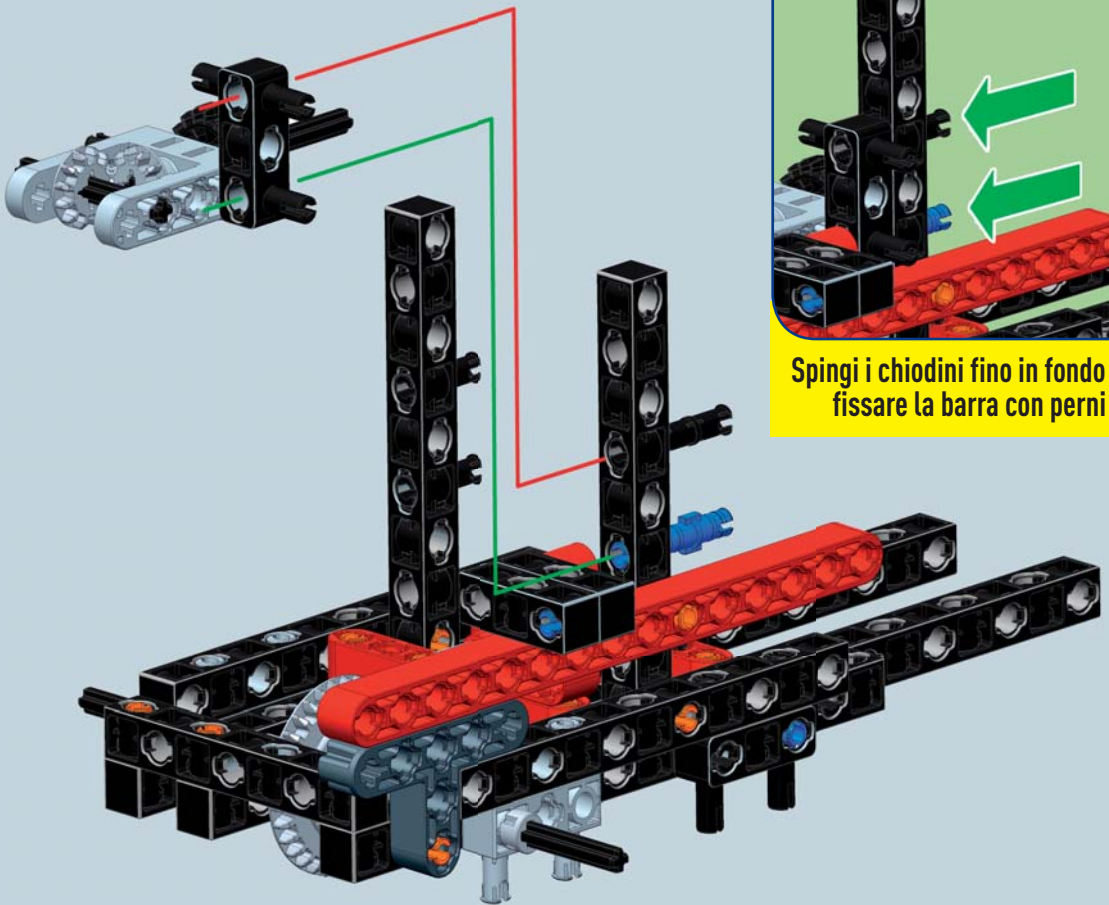

Spingi i chiodini fino in fondo per fissare la barra con perni



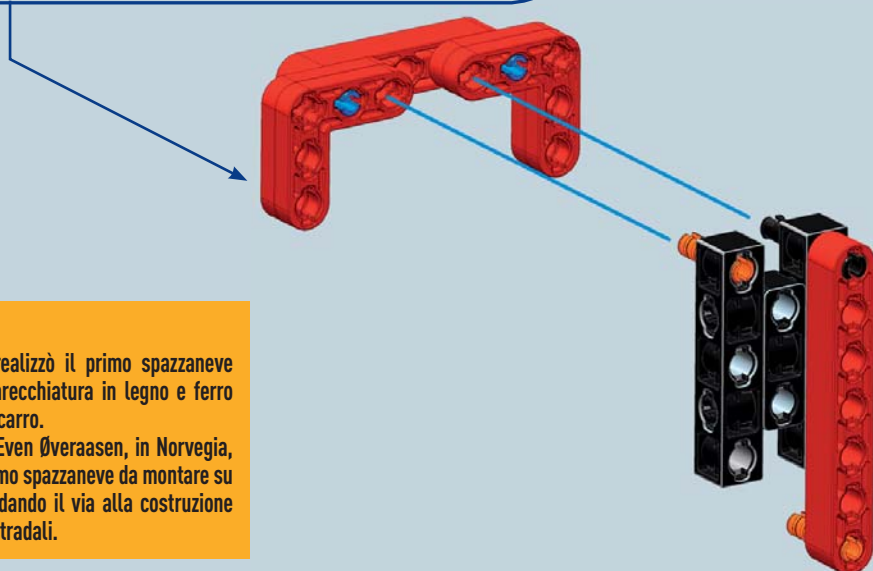
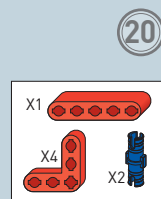
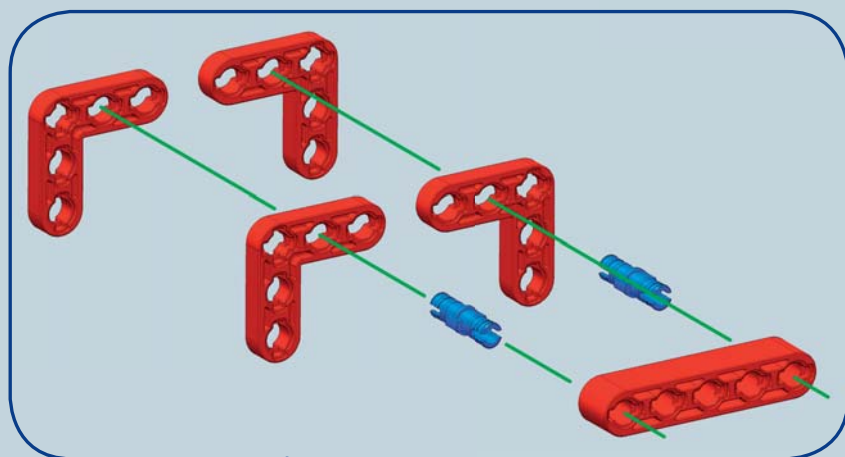
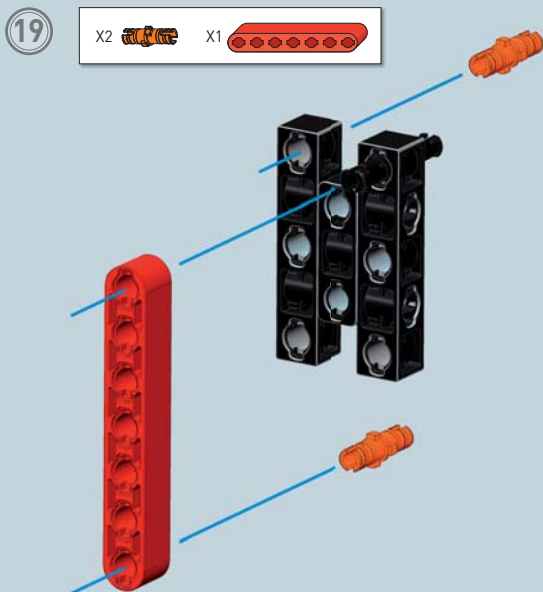
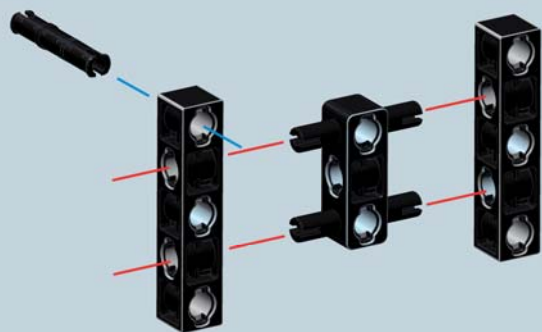
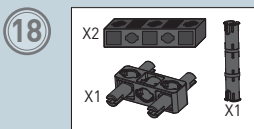

### Notizie tecniche e curiosità

Anno 1911 - David I Munson realizzò il primo spazzaneve montando un'apparecchiatura in legno e ferro battuto su un autocarro.

Anno 1923 - i fratelli Hans ed Even Øveraasen, in Norvegia, costruirono un primo spazzaneve da montare su di un automezzo, dando il via alla costruzione degli spazzaneve stradali.

21

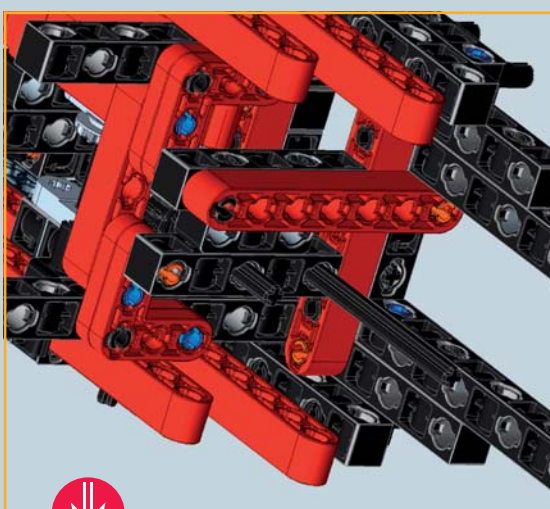

## Rapporto di trasmissione

MOTRICE



18

CONDOTTA

All'interno del telaio abbiamo creato un sistema di trasmissione accoppiando in verticale le ruote dentate da 18. Calcoliamo il rapporto di trasmissione:

$$\frac{18 \text{ denti (ruota motrice)}}{18 \text{ denti (ruota motrice)}} = 1$$

Il rapporto è 1 e si dice imparziale, perché la ruota motrice e condotta girano alla stessa velocità.

22

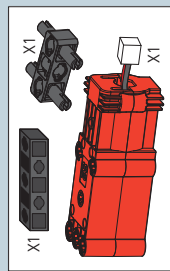
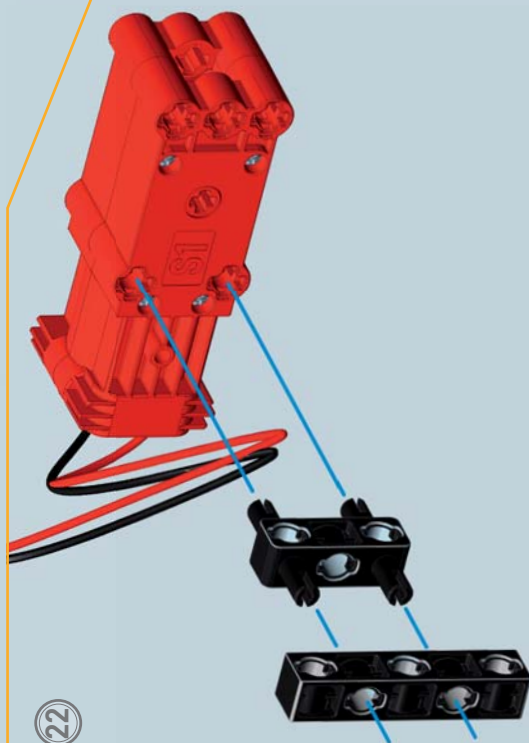

23

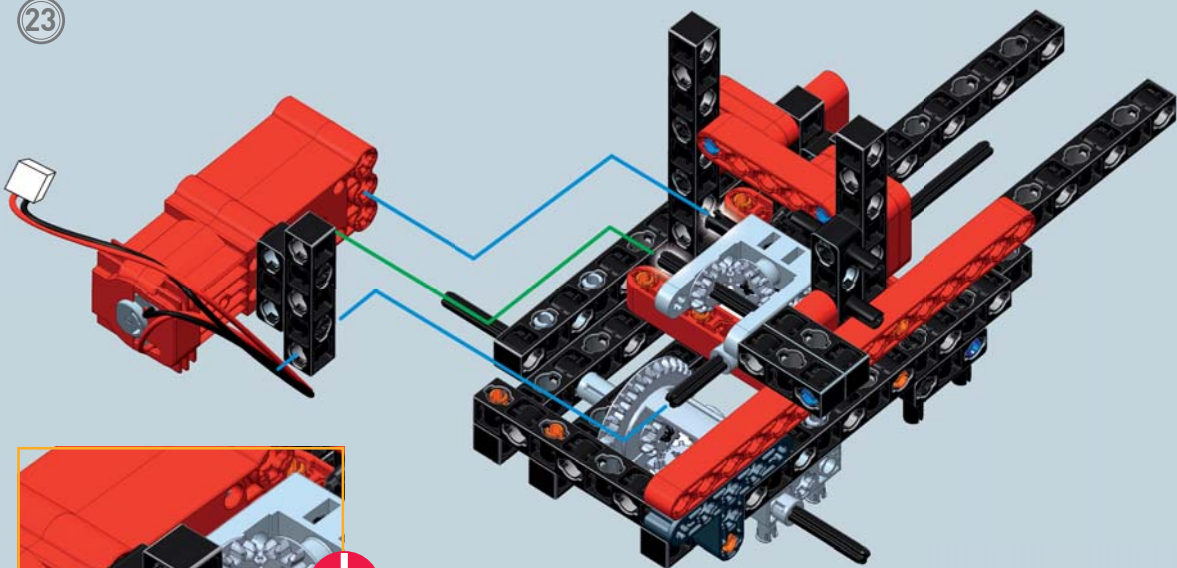

Verifica che l'astina 6 sia infilata nell'ultimo foro della barra doppia 5 fori.

24

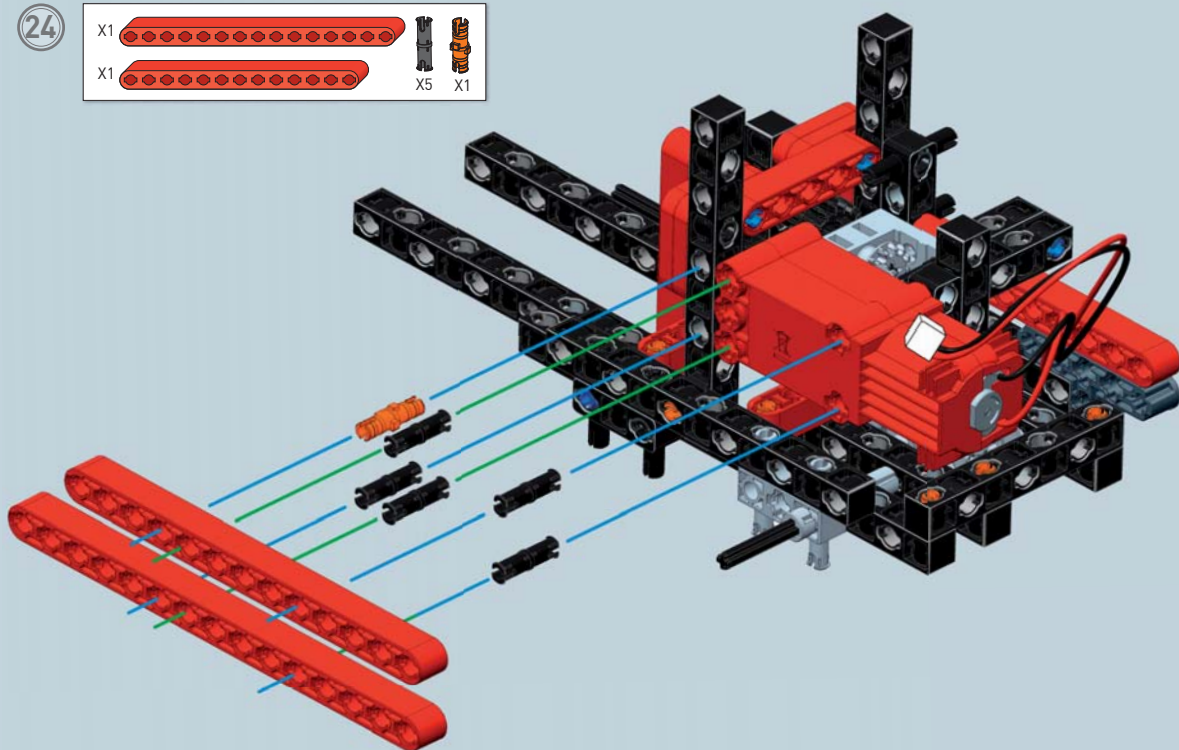
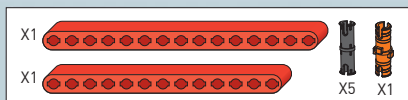

# II MOTORE A COMBUSTIONE INTERNA

Il motore a combustione interna è una macchina capace di trasformare l'energia chimica in potenza meccanica. Per generare la potenza meccanica abbiamo bisogno di:

**Combustibile:**  
Gas, benzina o gasolio

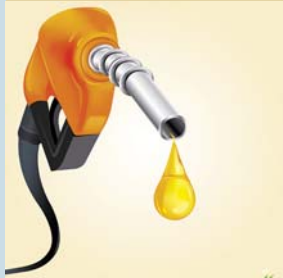

**Comburente:**  
ossigeno



Camera di combustione:

- VALVOLA
- CONDOTTO
- PISTONE
- CILINDRO
- BIELLA
- ALBERO MOTORE

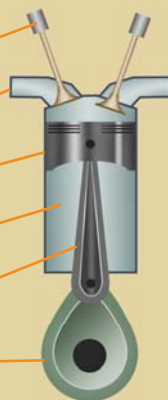

Come funziona? Le fasi che consentono la combustione sono in tutto 4:

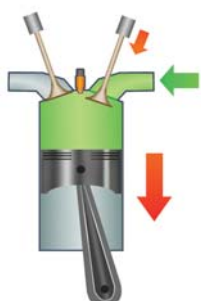

### FASE 1

**Aspirazione:** il pistone scende. L'aria o la miscela aria/combustibile viene risucchiata nel cilindro.



### FASE 2

**Compressione:** il pistone sale. La miscela aria/combustibile viene compressa. Inizia la combustione.

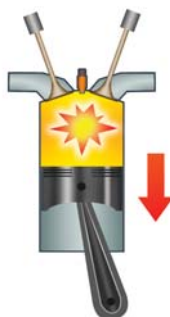

### FASE 3

**Accensione ed Espansione:** il pistone scende. Avviene la combustione che porta all'espansione istantanea dei gas. Il pistone viene spinto verso il basso.

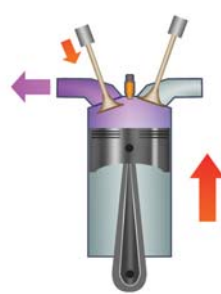

### FASE 4

**Scarico:** il pistone sale. I residui della combustione vengono espulsi dal cilindro.

Ad ogni ciclo corrispondono 2 rotazioni dell'albero motore, che di conseguenza trasmette il moto agli altri organi meccanici del veicolo.

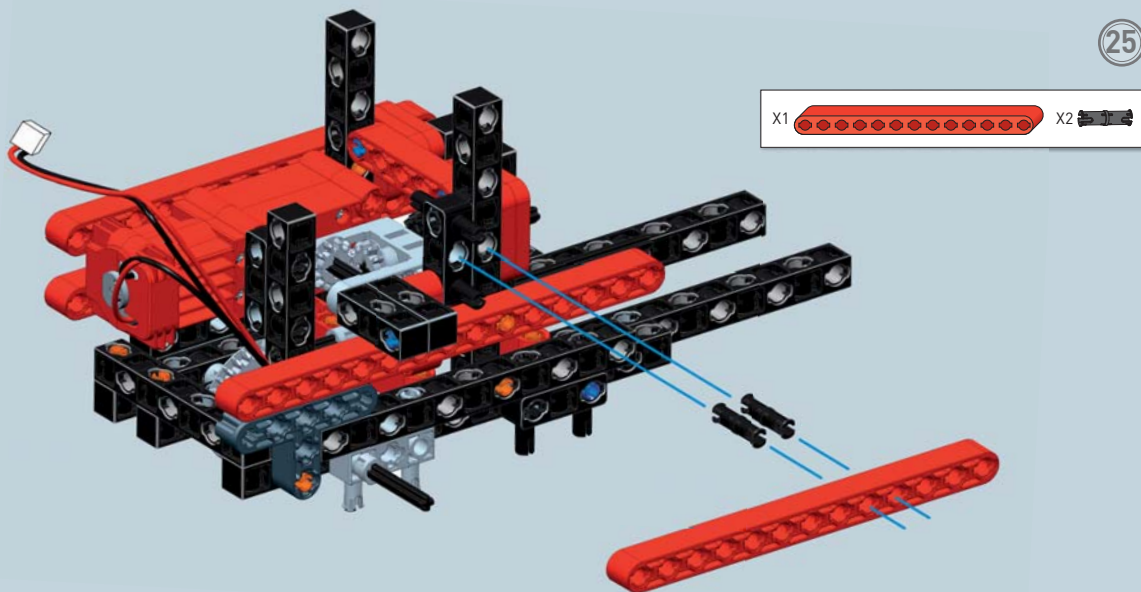

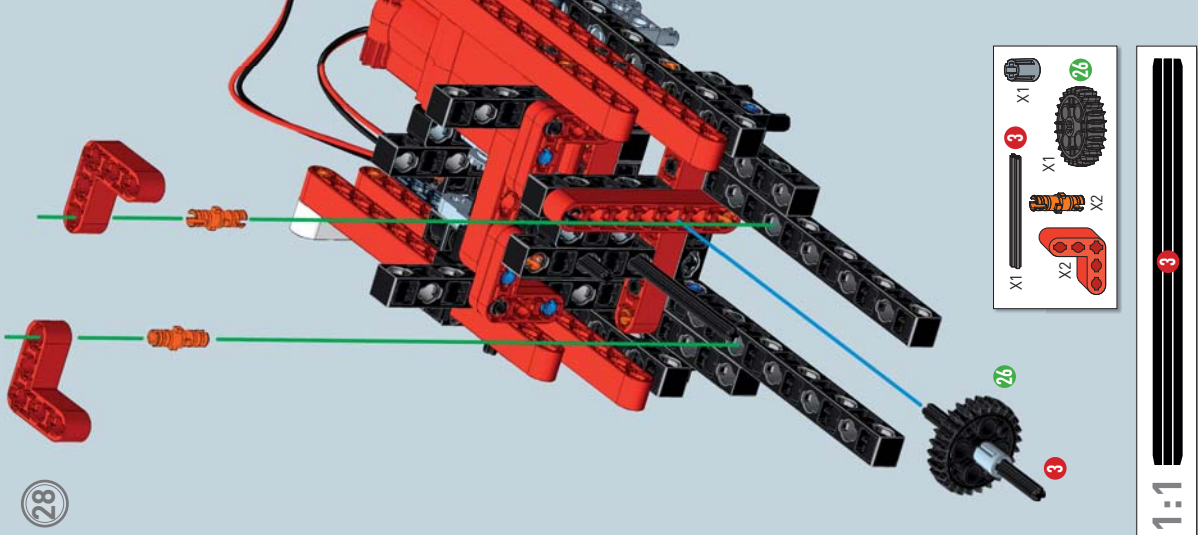

28

- X1 X1
- X1 X1
- X2 X2
- X2 X2
- X1 X1
- X1 X1

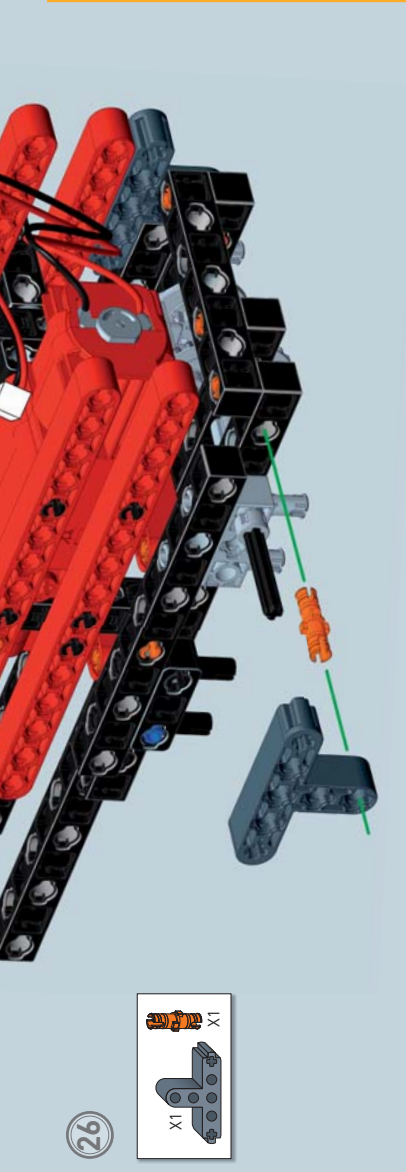

26

- X1 X1
- X1 X1

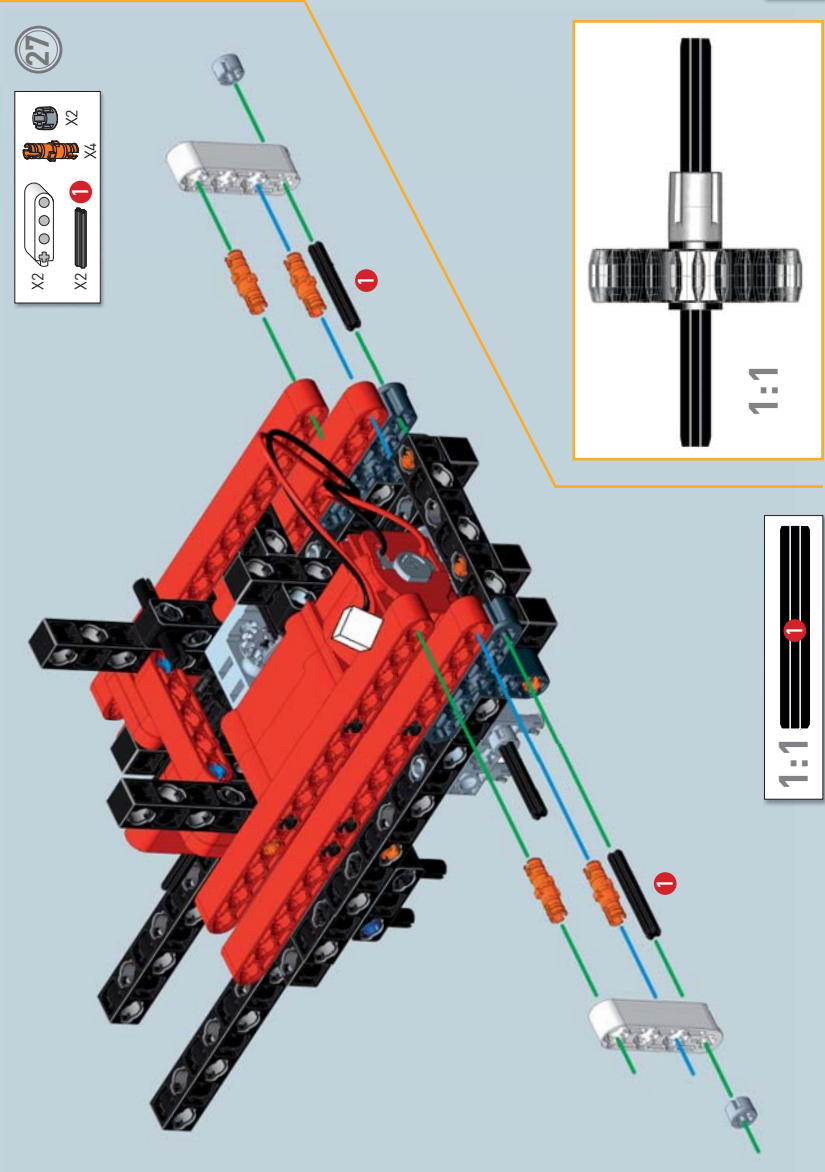

27

- X2 X2
- X2 X2
- X4 X4
- X1 X1

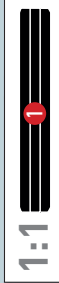
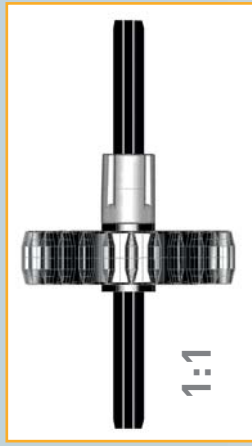

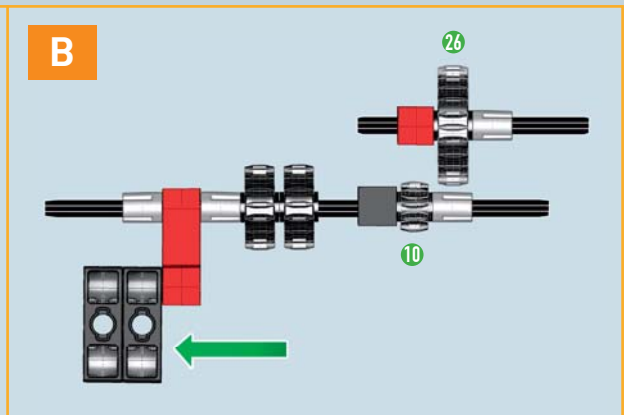
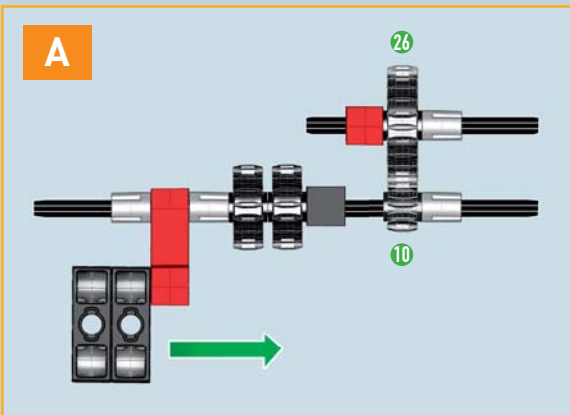
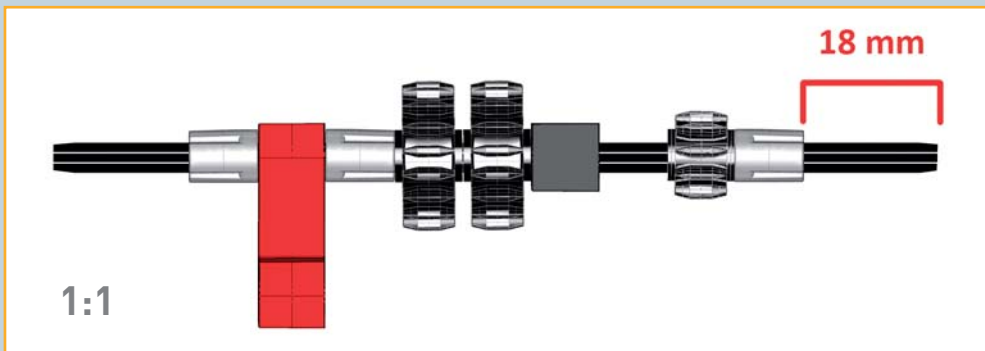
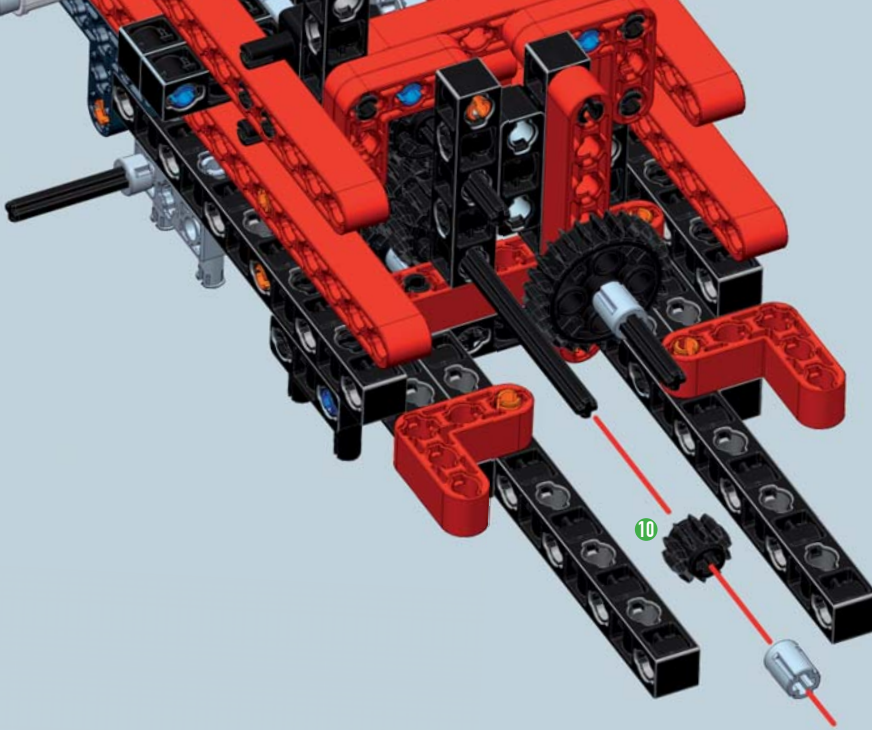

Sposta in avanti e indietro la leva laterale per verificare il corretto funzionamento del meccanismo di scambio: spingendola in avanti le due ruote dentate da 10 e 26 vengono accoppiate (A); tirandola indietro le ruote dentate si disaccoppiano (B).

30

X1

X2

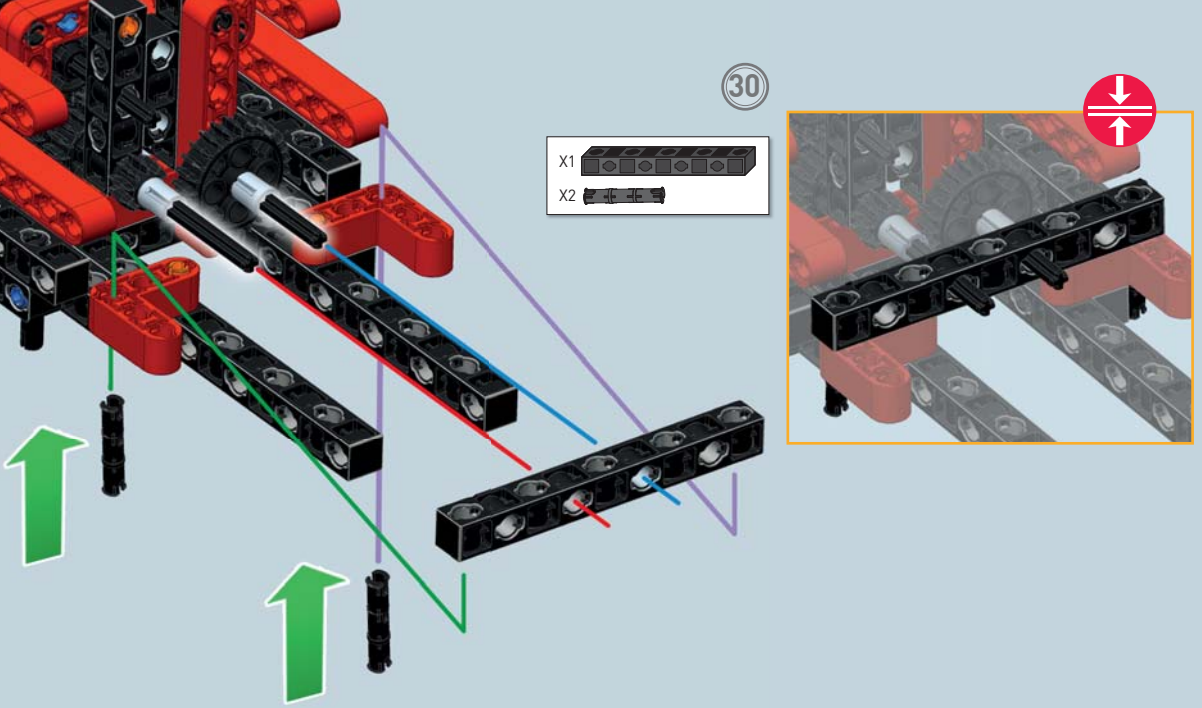

31

X2

X2

X2

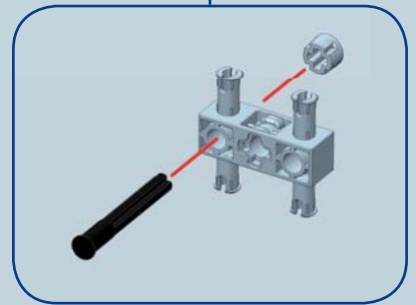
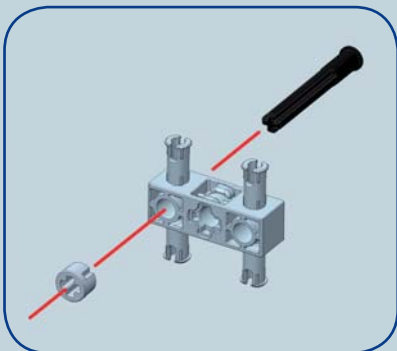



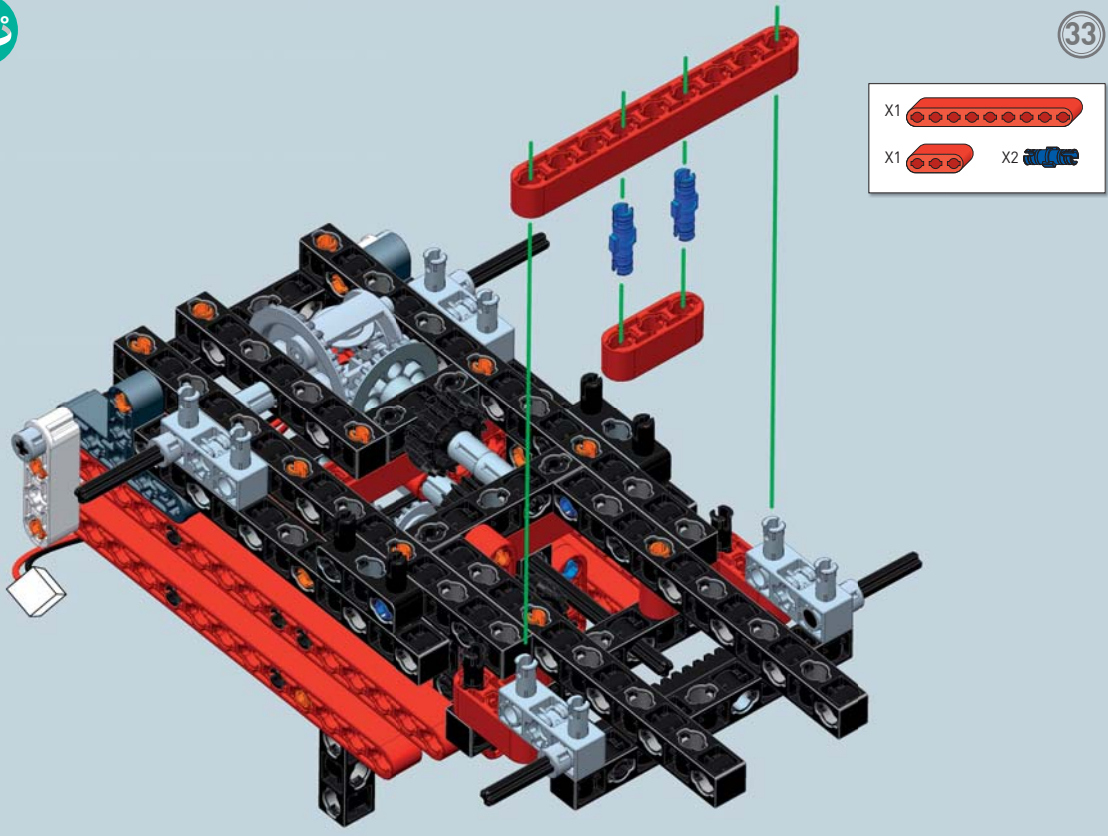
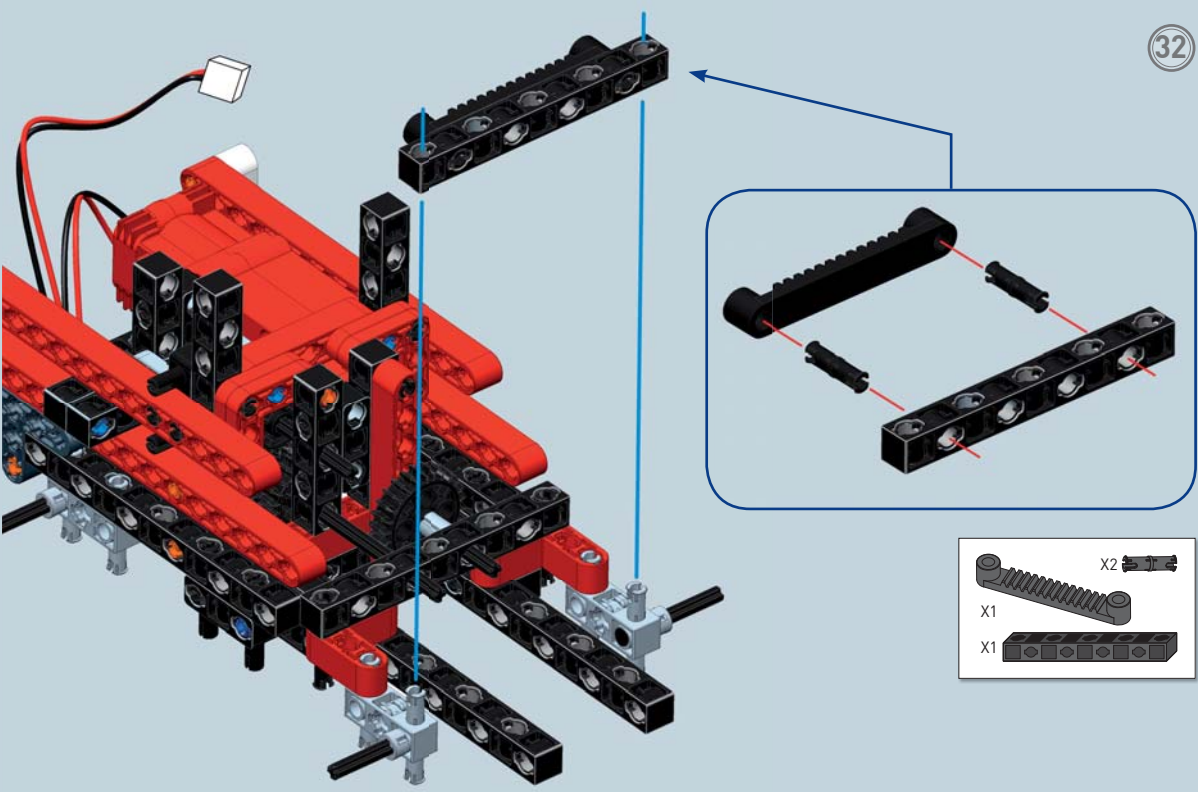

34

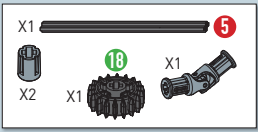
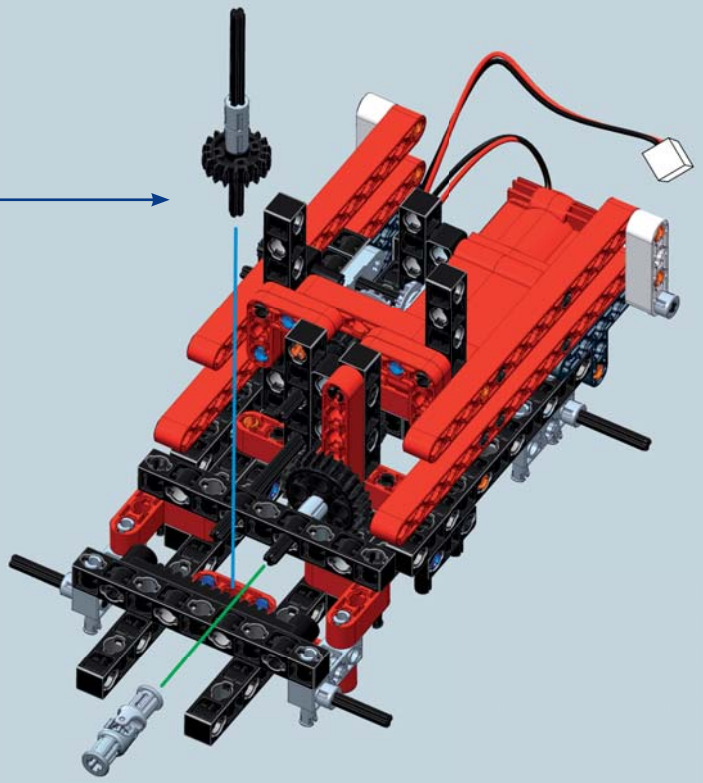
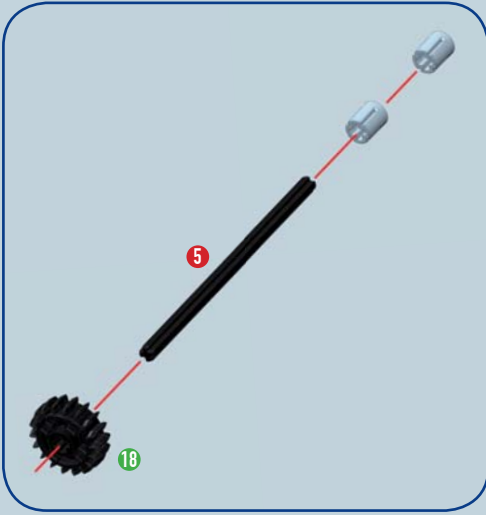

Per assemblare il giunto cardanico  
seguì le indicazioni stampate sul  
foglio delle avvertenze

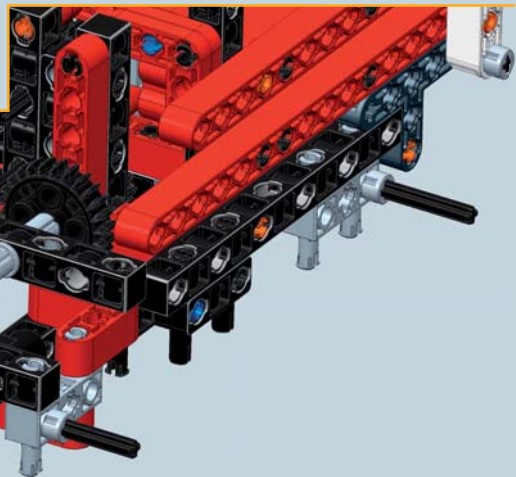

35

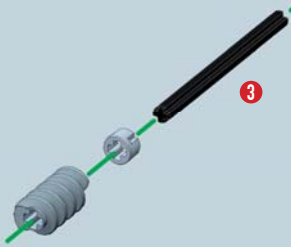
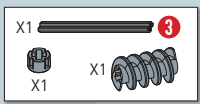

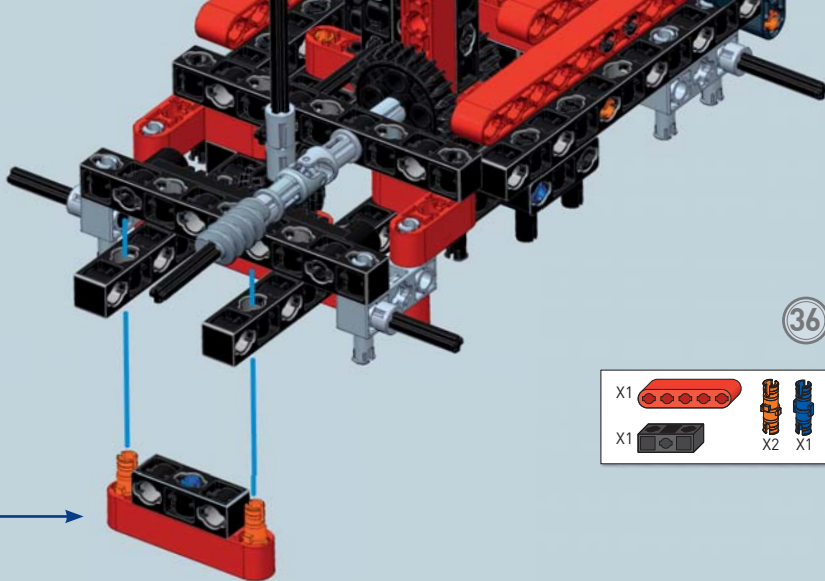
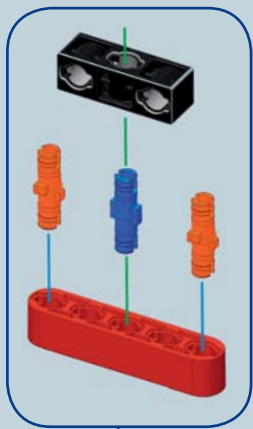

36

- X1
- X1
- X2
- X1

37

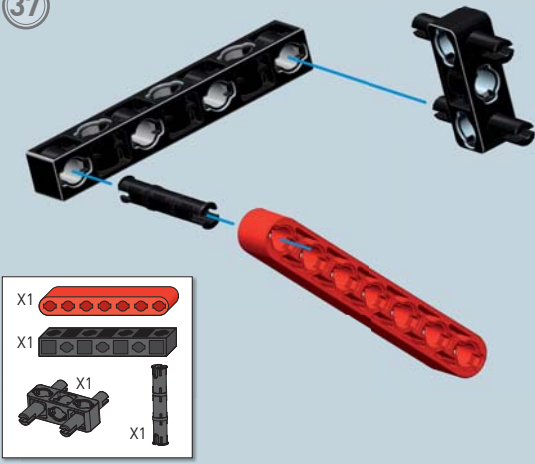

- X1
- X1
- X1
- X1

38

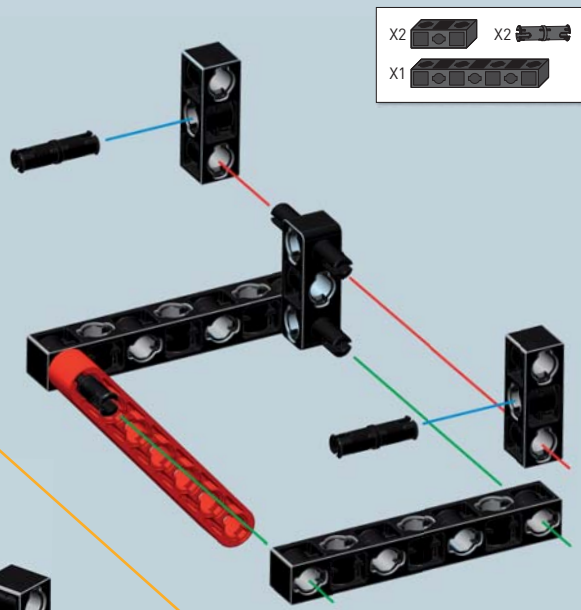

- X2
- X1
- X2

39

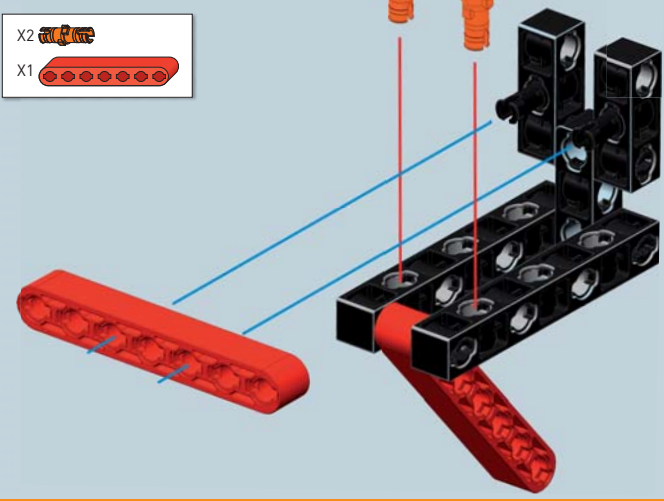

- X2
- X1

40

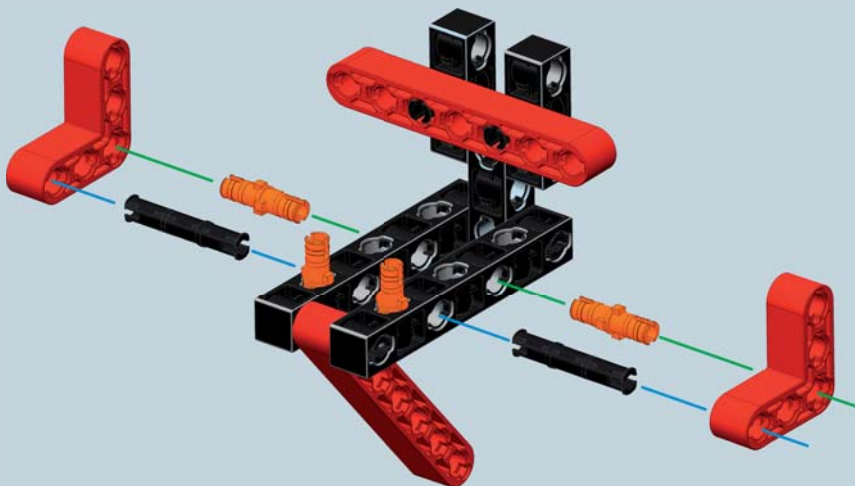
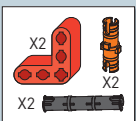

41

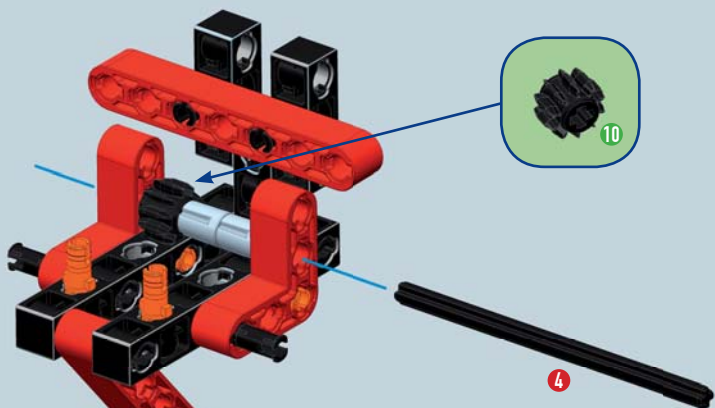

42

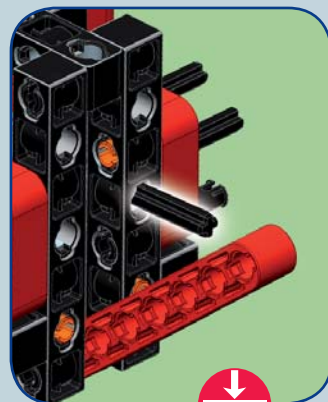
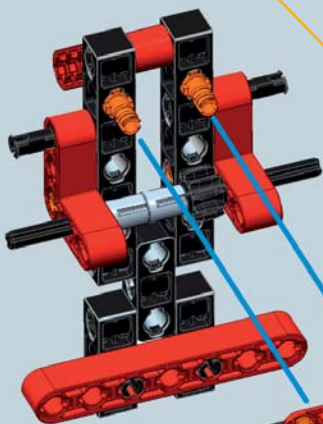

La ruota da 10 denti accoppia con la vite senza fine.

43

180°

- X1
- X2
- X2

44

- X1
- X1
- X2

45

- X1
- X1
- X2
- X1

46

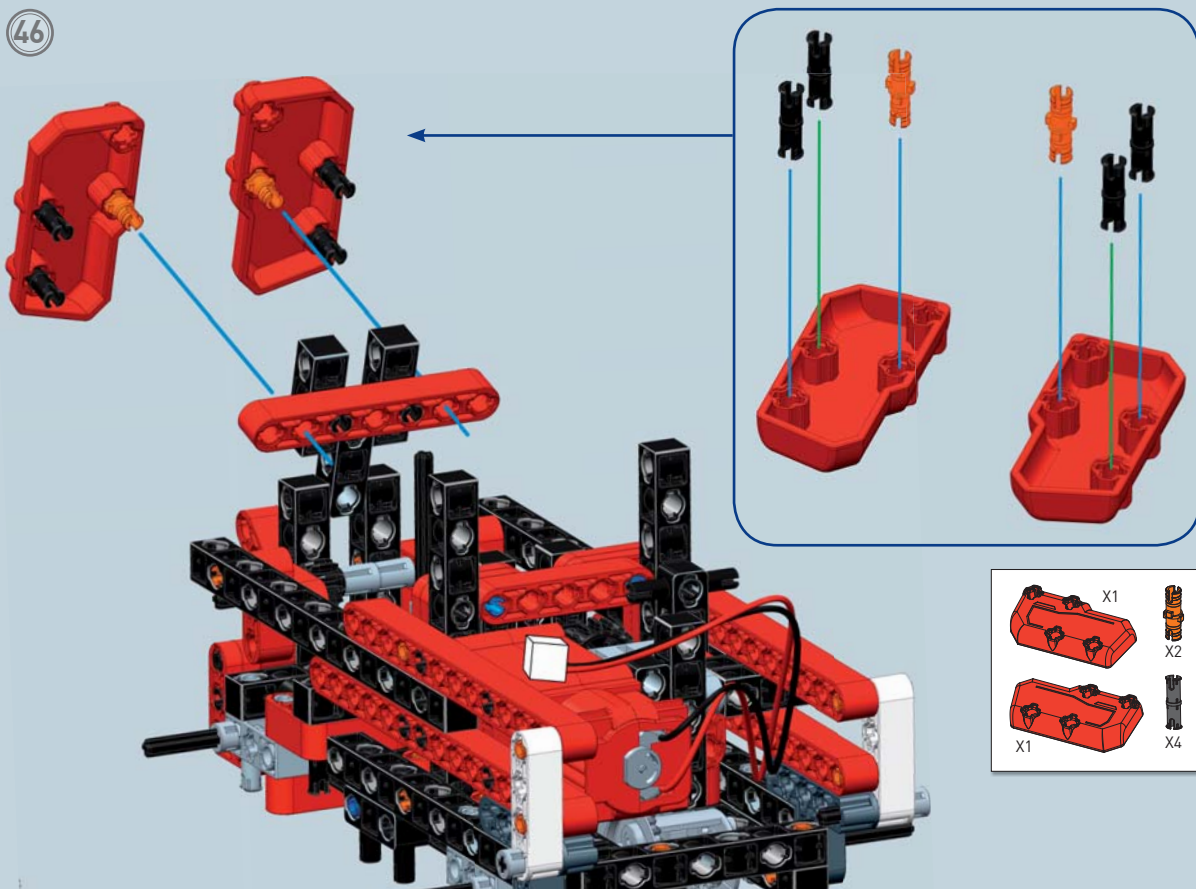

47

- X1
- X2

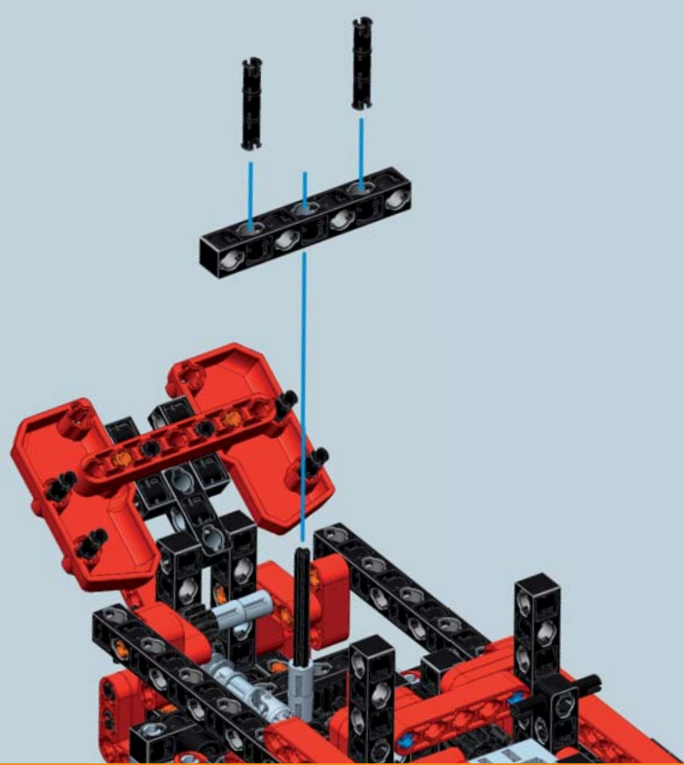

**Notizie tecniche e curiosità**

La lama montata davanti al muso dei fuoristrada è utilizzata per carichi nevosi leggeri. Viene di solito movimentata attraverso motori elettrici che azionano appositi cilindri idraulici. In questo modo la lama può essere orientata con precisione sia in verticale che in orizzontale.





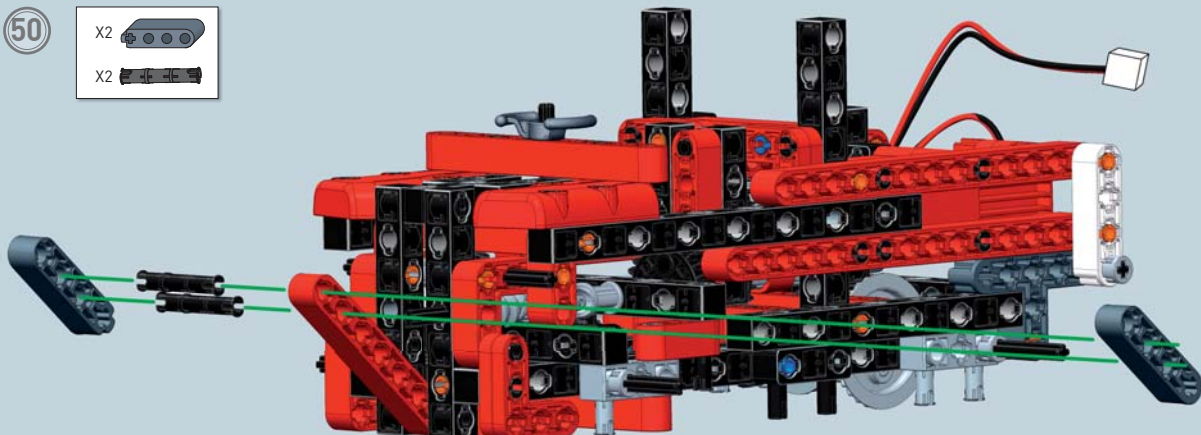
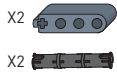
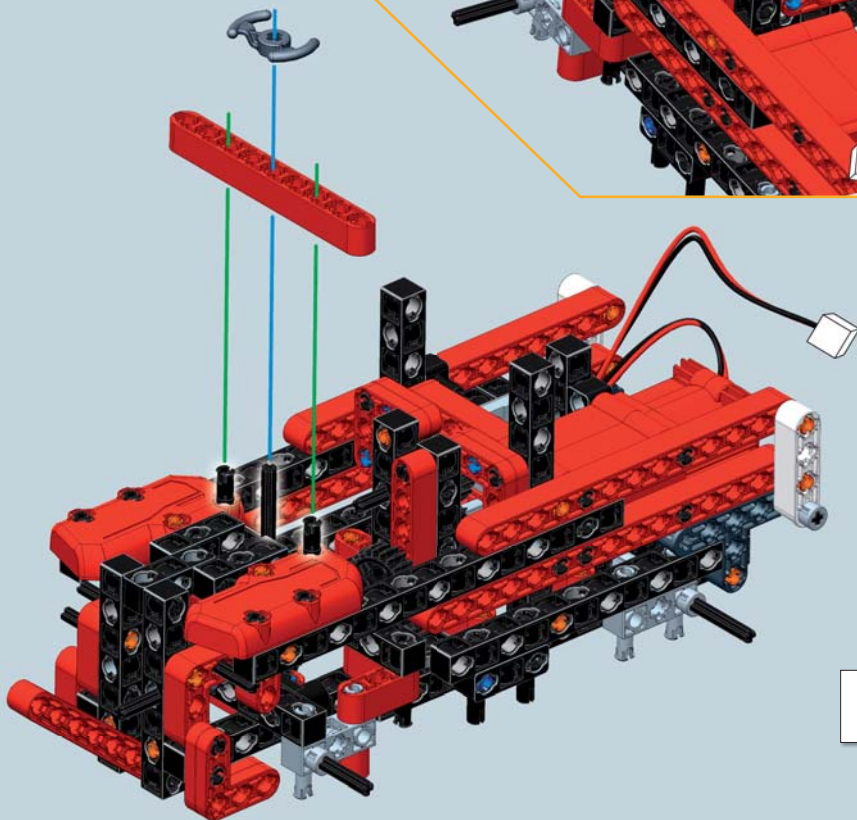
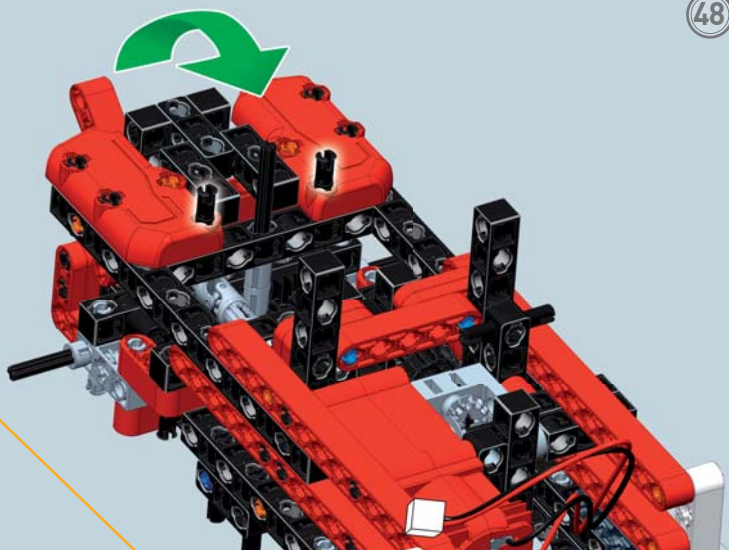

Richiudi il cofano fissandolo al telaio come in figura.

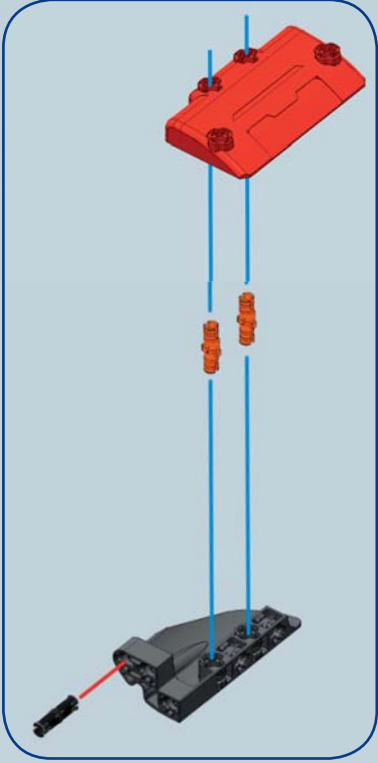

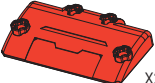

51

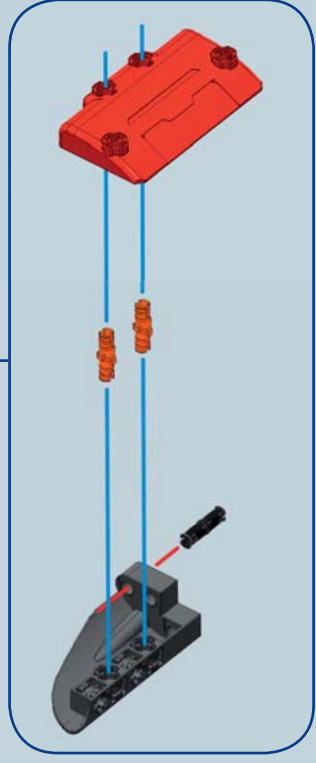

-  X2
-  X1
-  X1
-  X4
-  X2



52

- X1 
- X2 

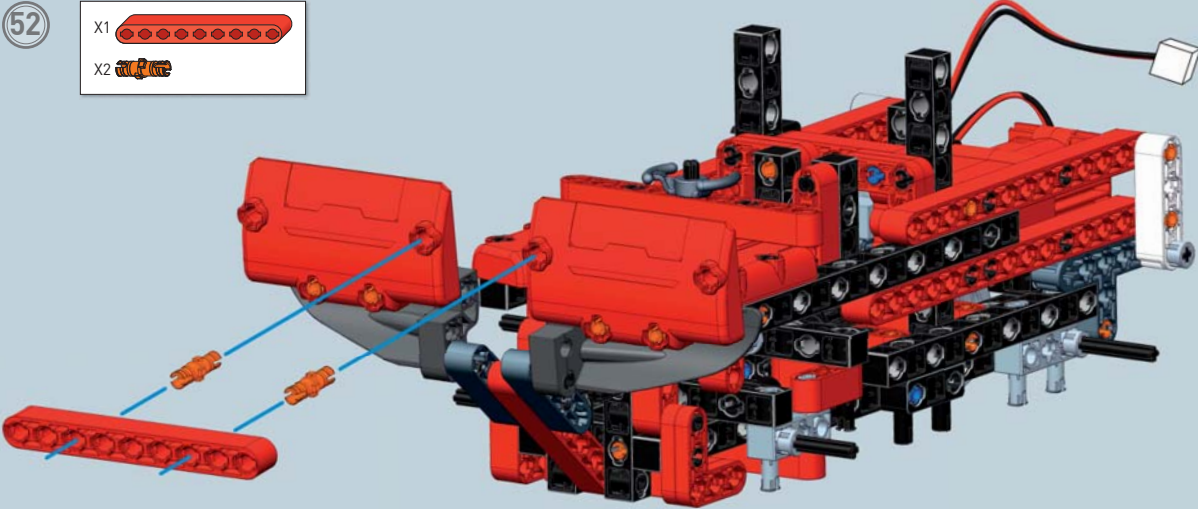



53

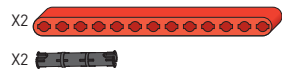
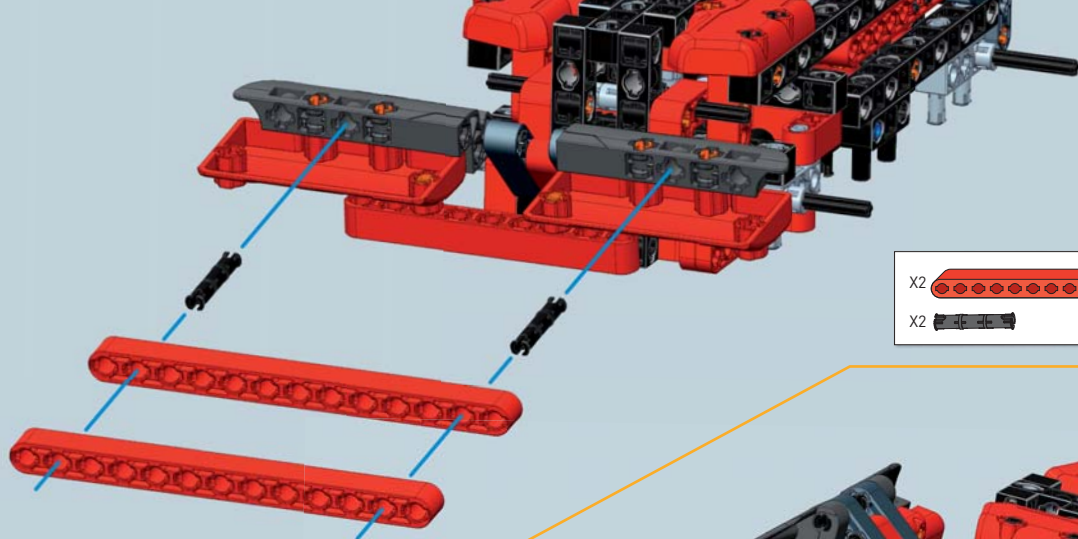

54

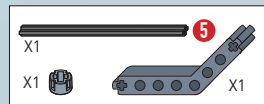
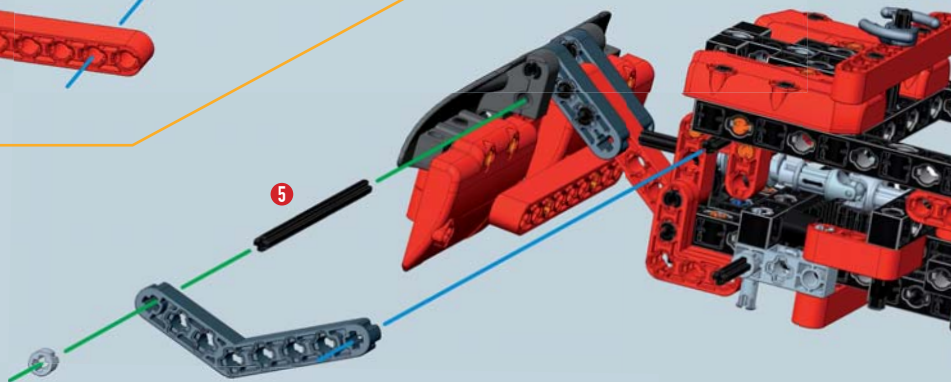

55

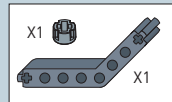
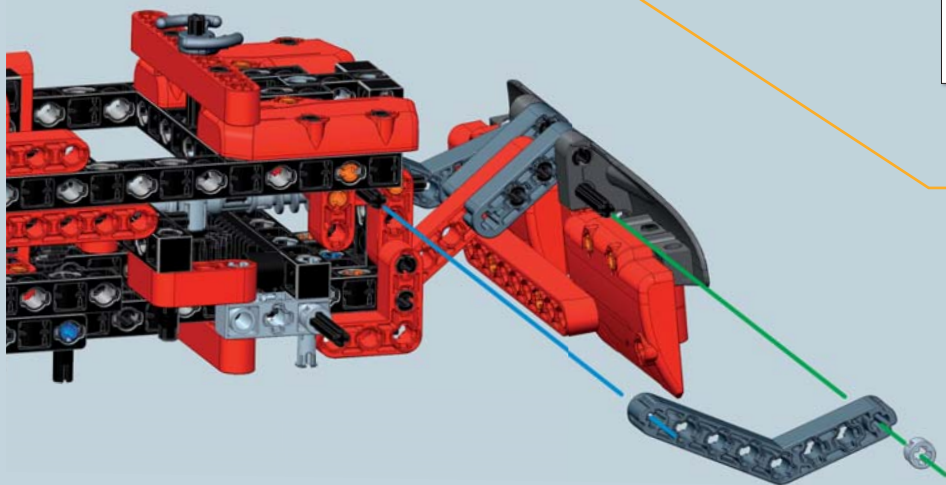

#### Notizie tecniche e curiosità

Quando si verifica un accumulo eccessivo di neve, vengono impiegati spazzaneve a turbina che risucchiano la neve gettandola ai lati della strada.



56

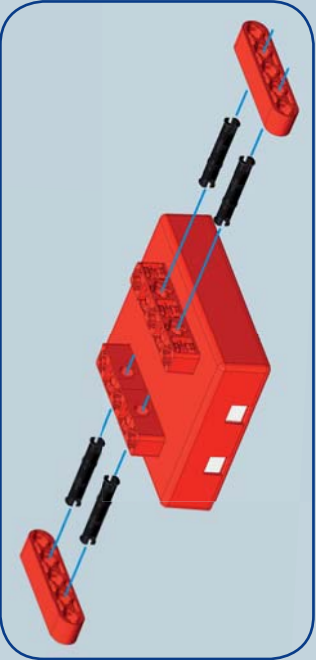
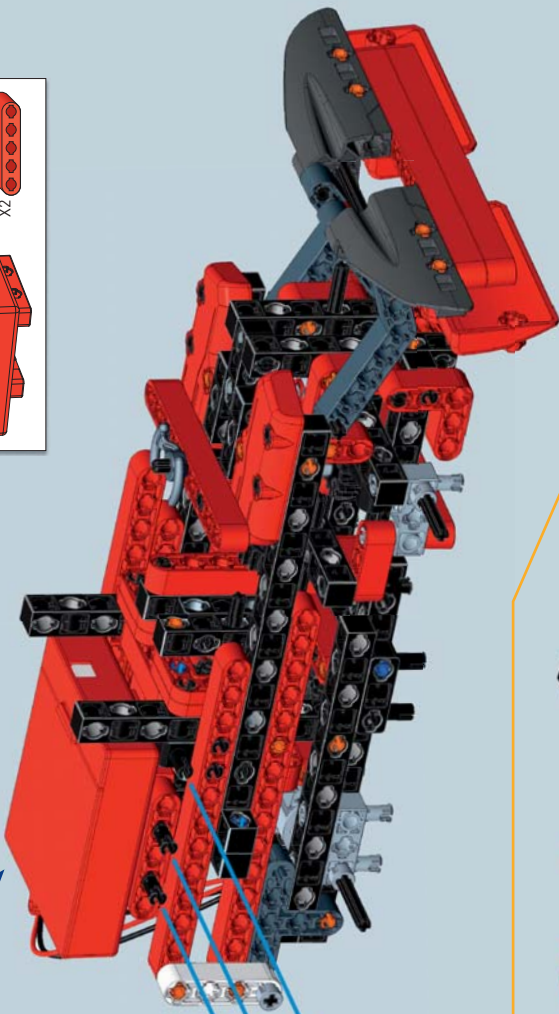
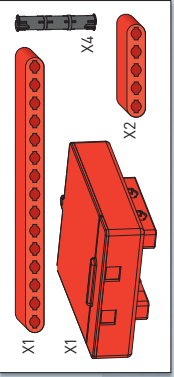

57

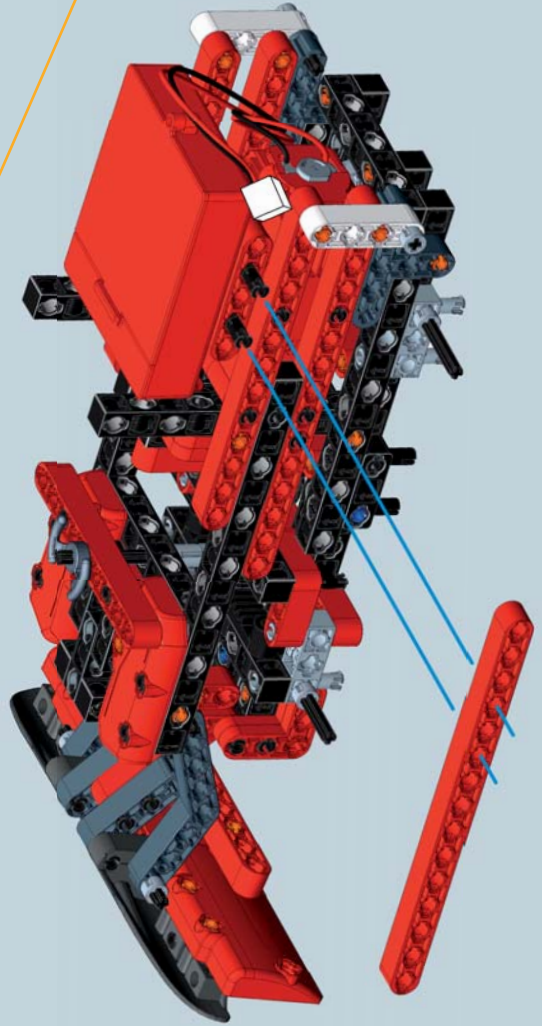
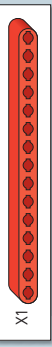

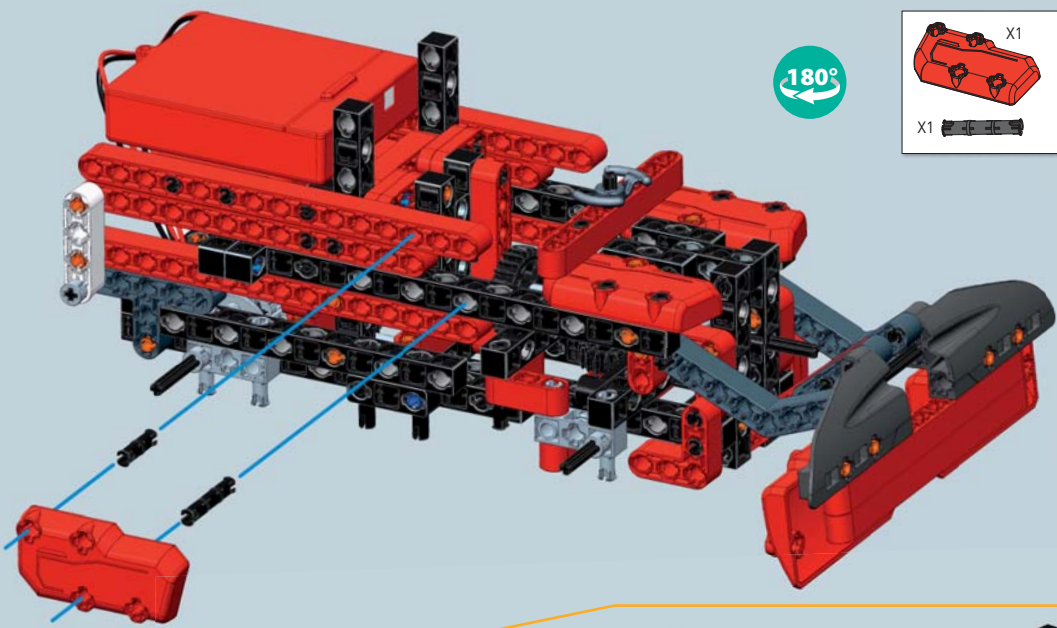

X1

X1

X1

58

59

X1

X1

X1

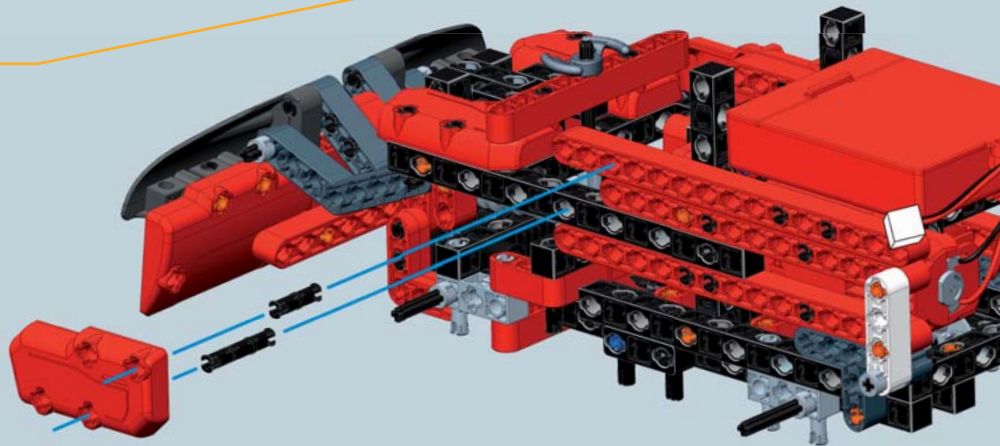

180°

60

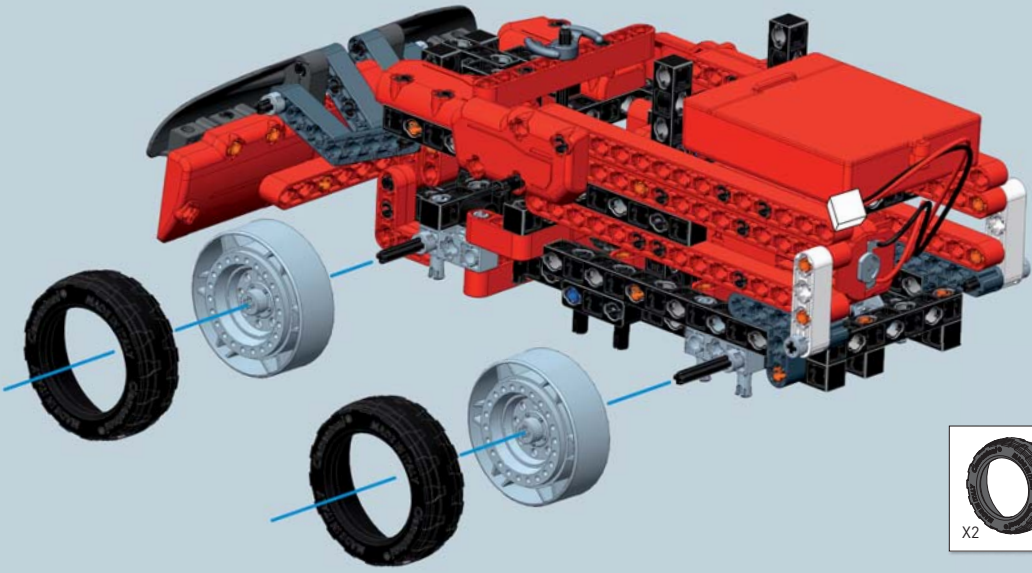

X2

X2

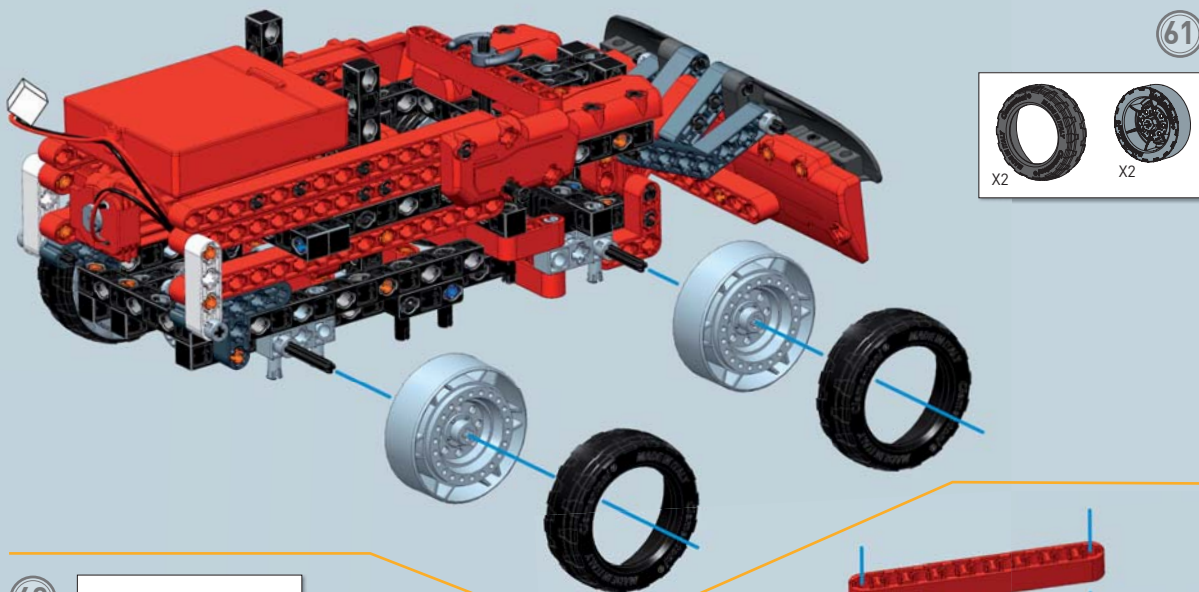

62

X1



63

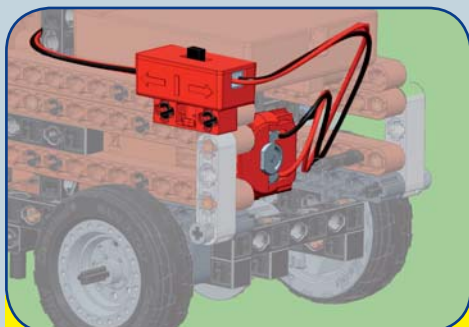

Connetti il cavo del motore allo switch  
e il cavo dello switch al vano batterie

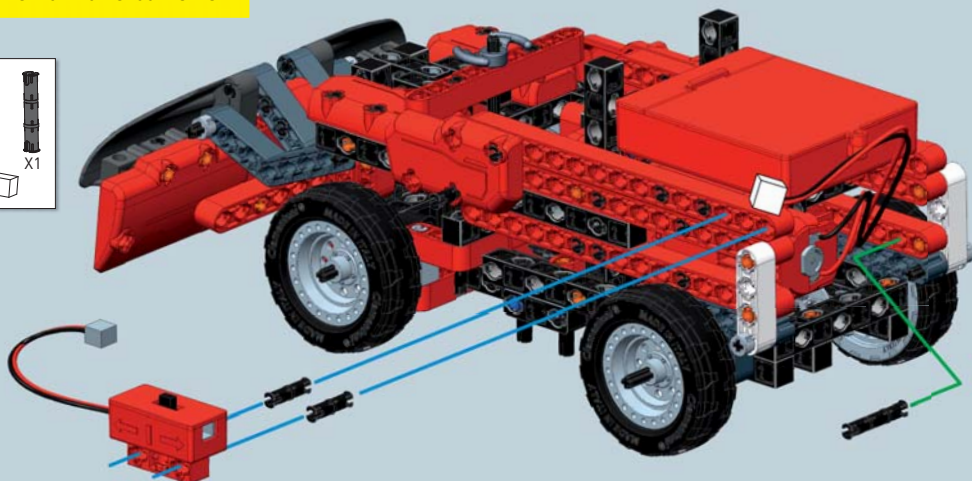
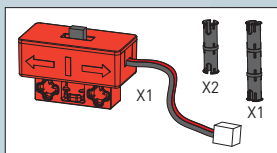
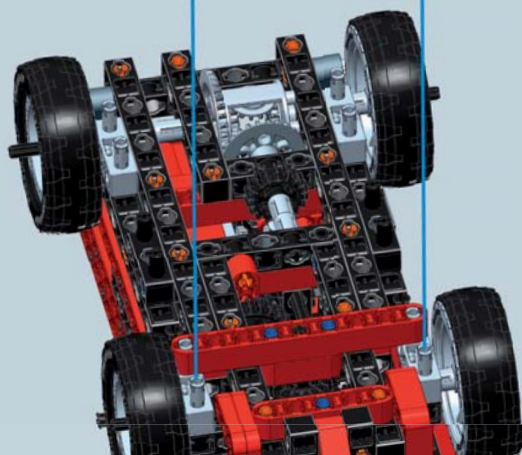

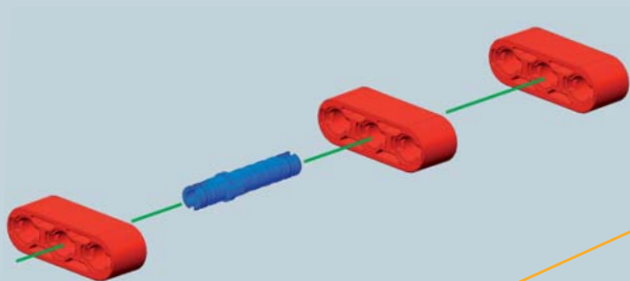

- X3
- X1

64

- X2
- X2
- X2

65

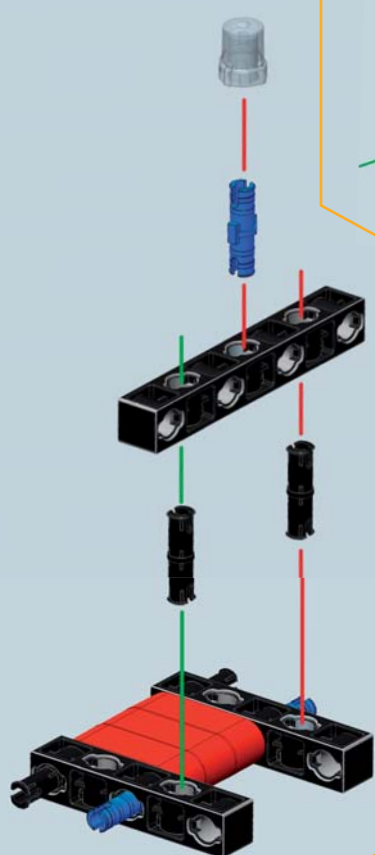
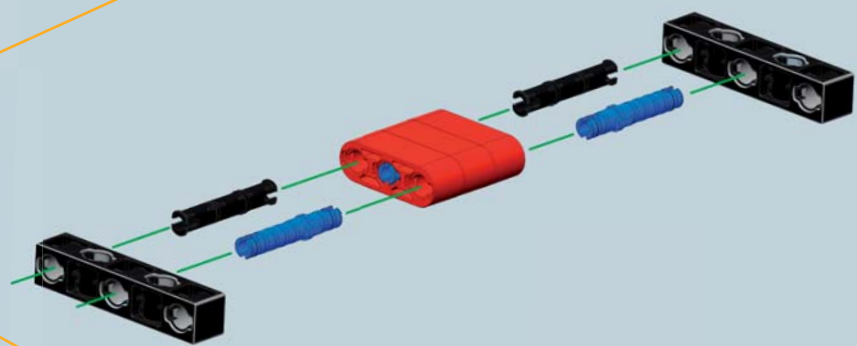

- X1
- X1
- X2
- X1

66

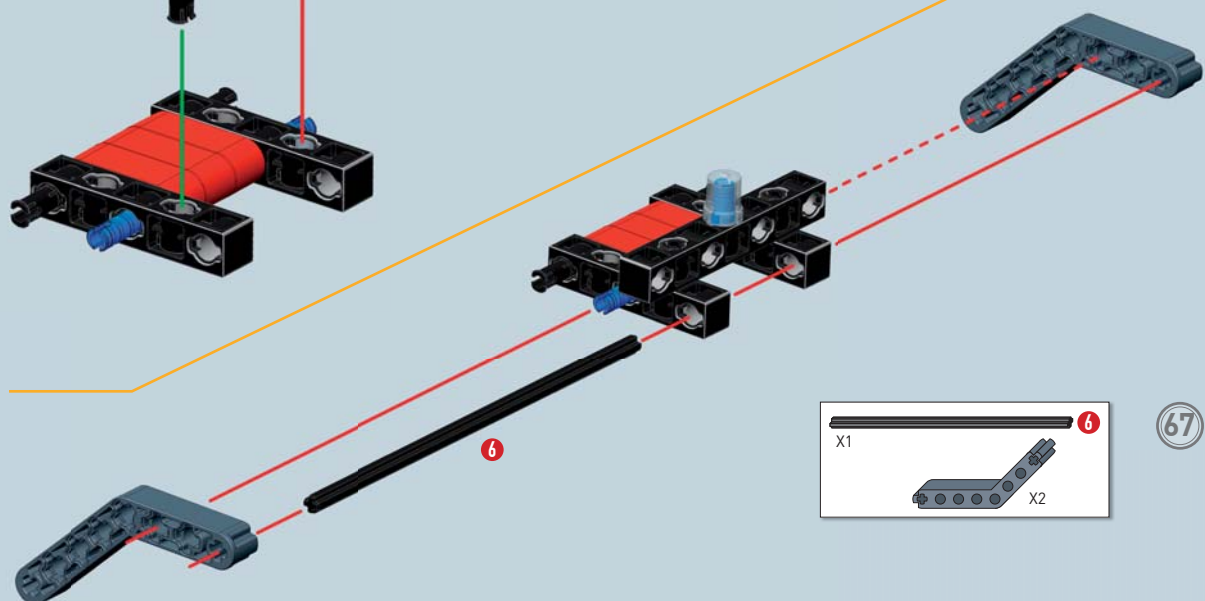

- X1
- X2

67

1:1 6

68

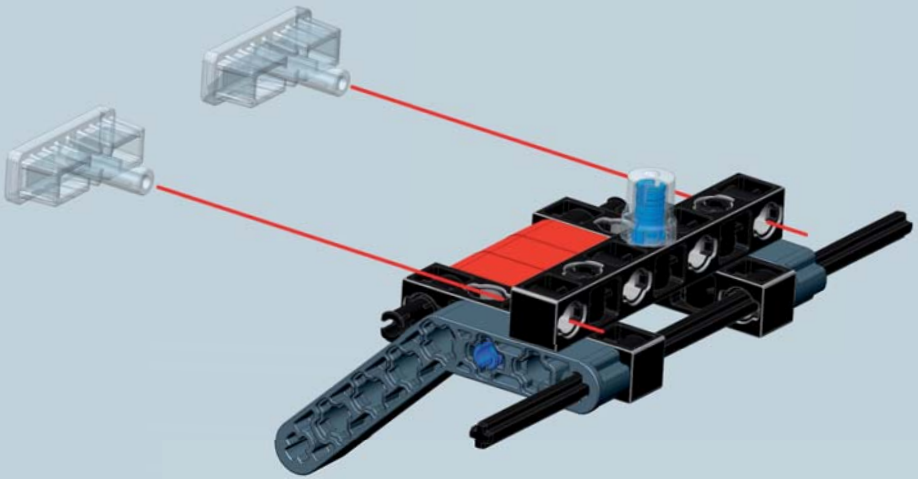
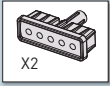

69

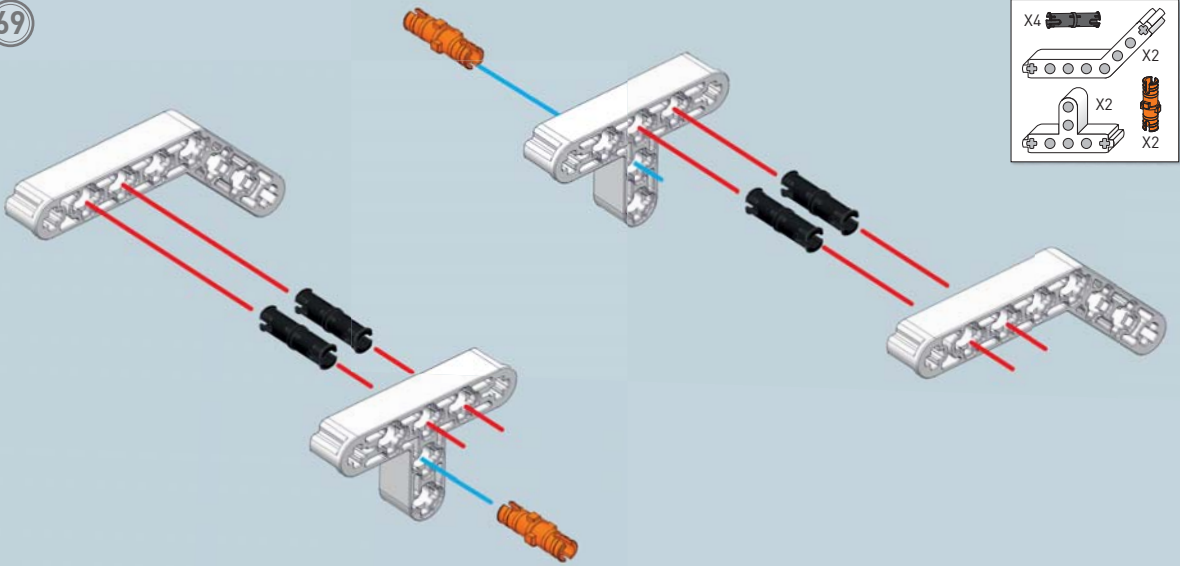
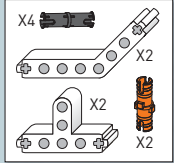

70

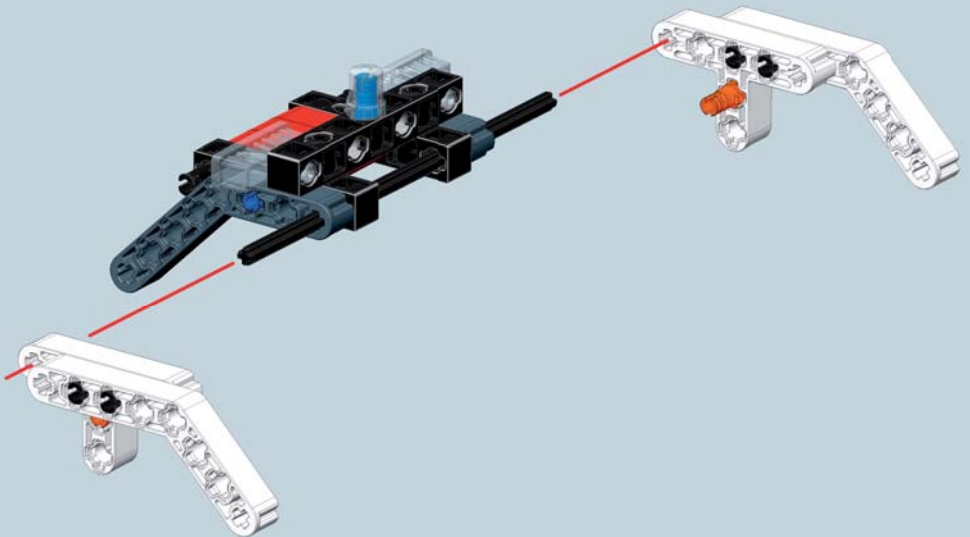

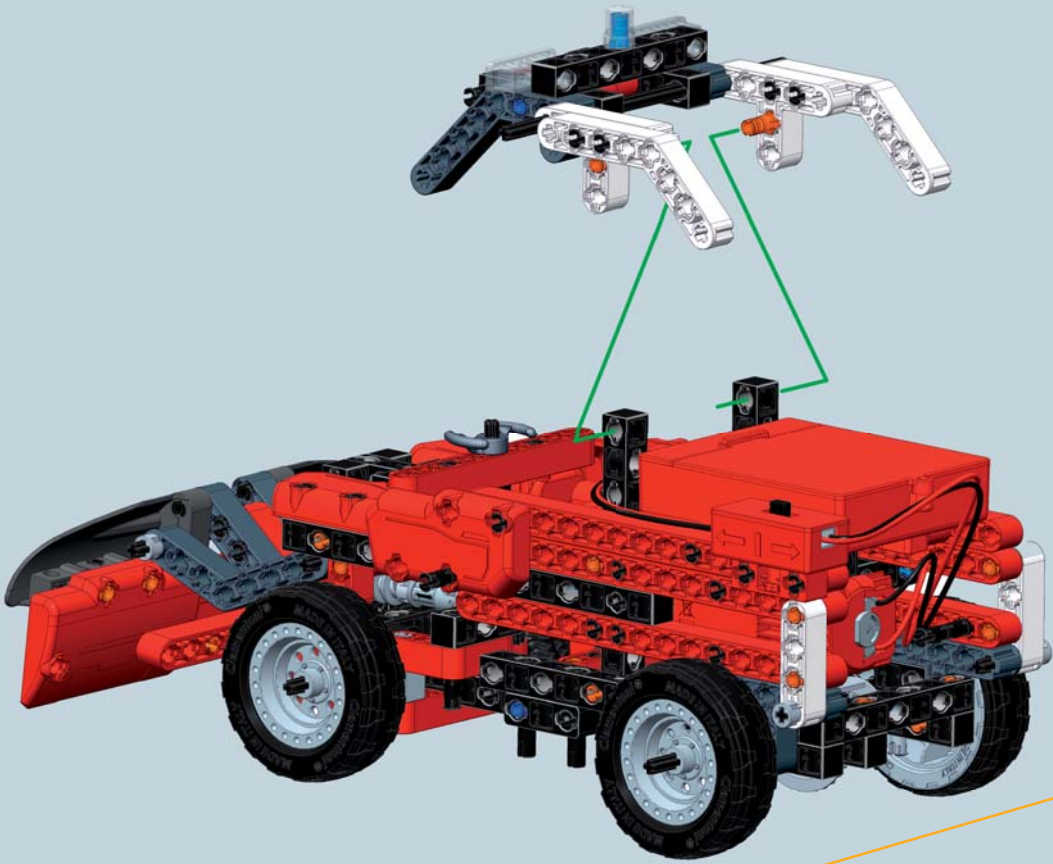

- X2 
- X2 
- X2 

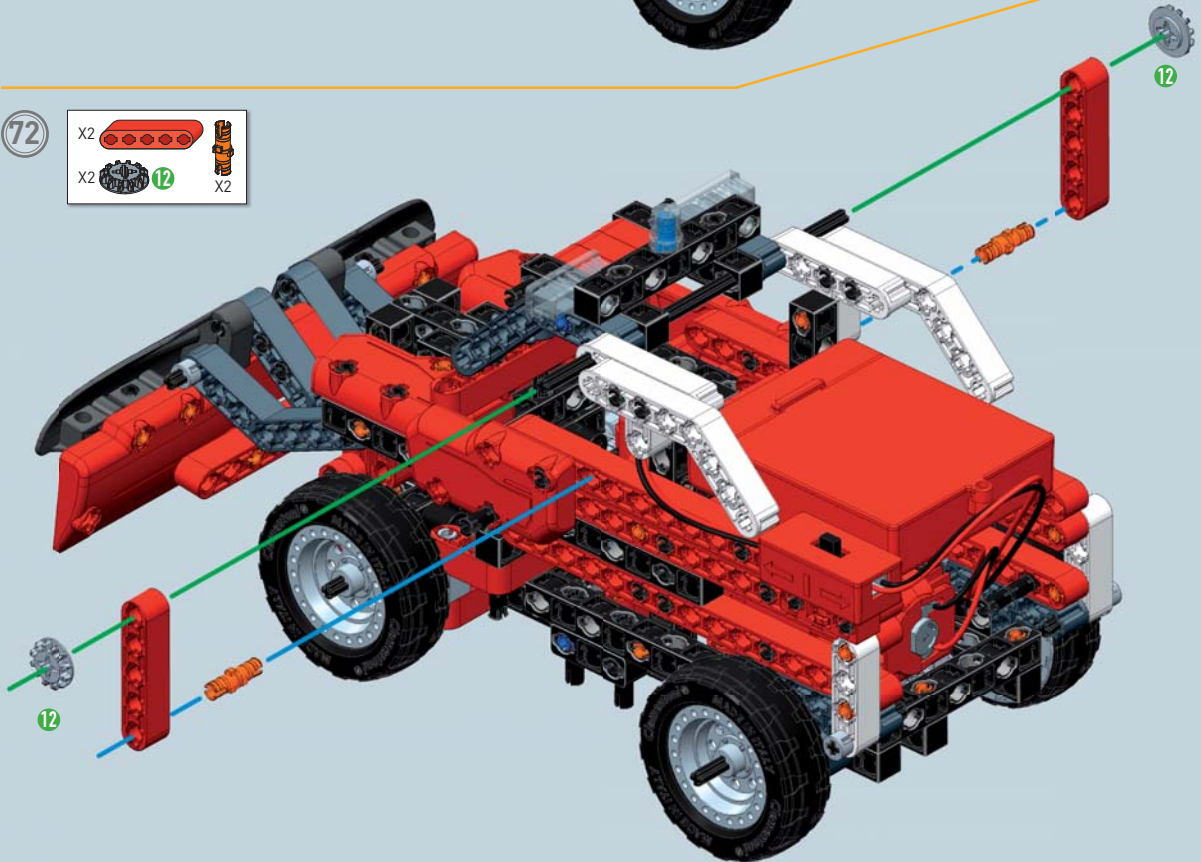

73

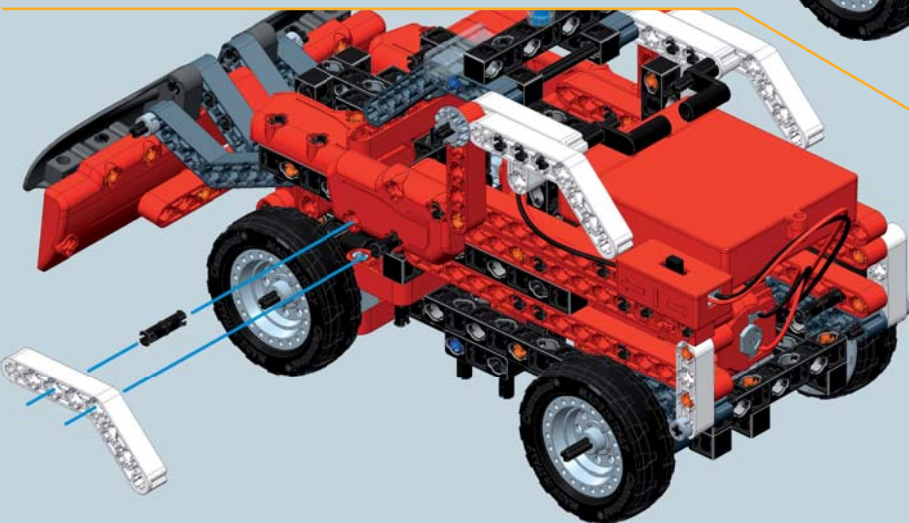
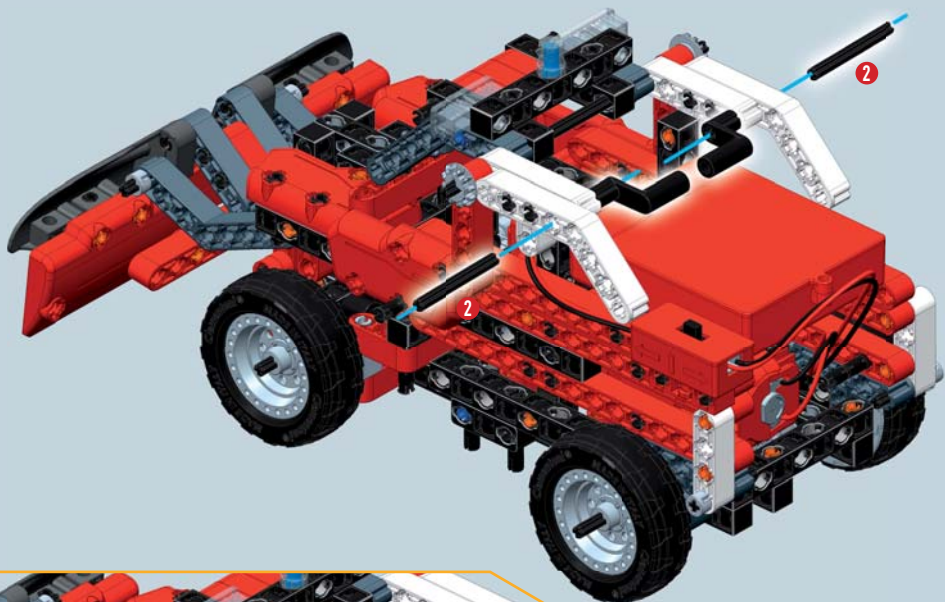
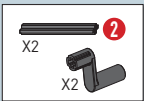

74

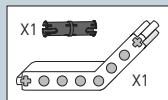

75

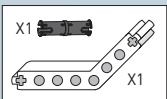



## Modalità di gioco

Puoi utilizzare il motore elettrico per azionare le ruote posteriori o la lama anteriore.

### AZIONAMENTO DELLE RUOTE POSTERIORI

Tira indietro la leva laterale per trasferire la rotazione del motore alle ruote posteriori.

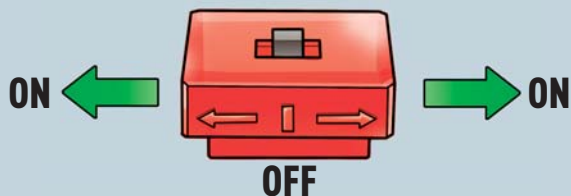

### AZIONAMENTO DELLA LAMA ANTERIORE

Spingi in avanti la leva laterale per azionare la lama anteriore.

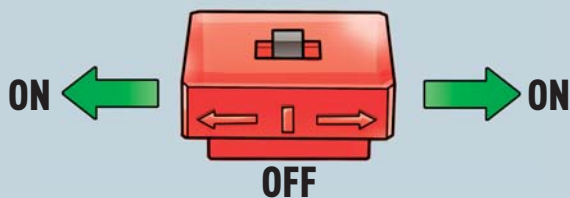
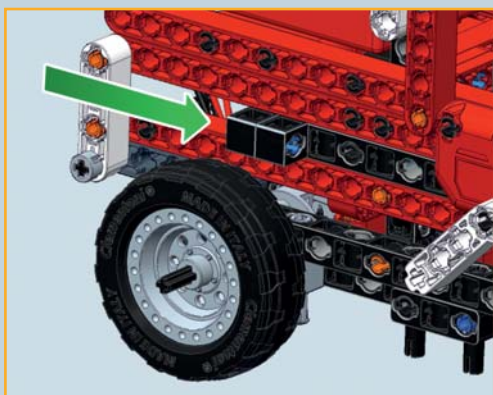



## L'ELISOCCORSO

L'obiettivo dell'elisoccorso è quello di portare soccorso a persone in pericolo di vita ed è possibile grazie all'uso di elicotteri dedicati. In virtù del tipo di intervento e soprattutto della conformazione del territorio, l'elicottero deve essere equipaggiato con strumenti specifici.

I tipi di interventi richiedono elicotteri ed equipaggi specializzati:

- Negli interventi **HEMS** (Servizio Medico di Emergenza con Elicotteri), gli elicotteri atterrano direttamente sulla scena dell'incidente in ambienti non impervi, ed effettuano missione di soccorso sanitario.
- Negli interventi **SAR-HHO** (Ricerca e salvataggio-Interventi dell'elicottero con verricello), le persone in pericolo si trovano in zone impervie, come ad esempio la montagna o il mare aperto, in cui l'elicottero non può atterrare. In questi casi si fa uso di elicotteri muniti di verricello.

1

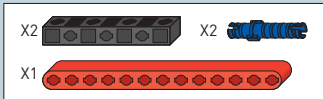
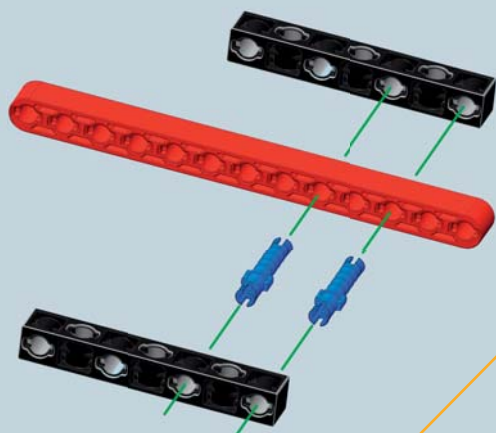

2

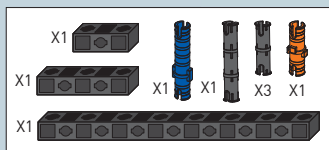
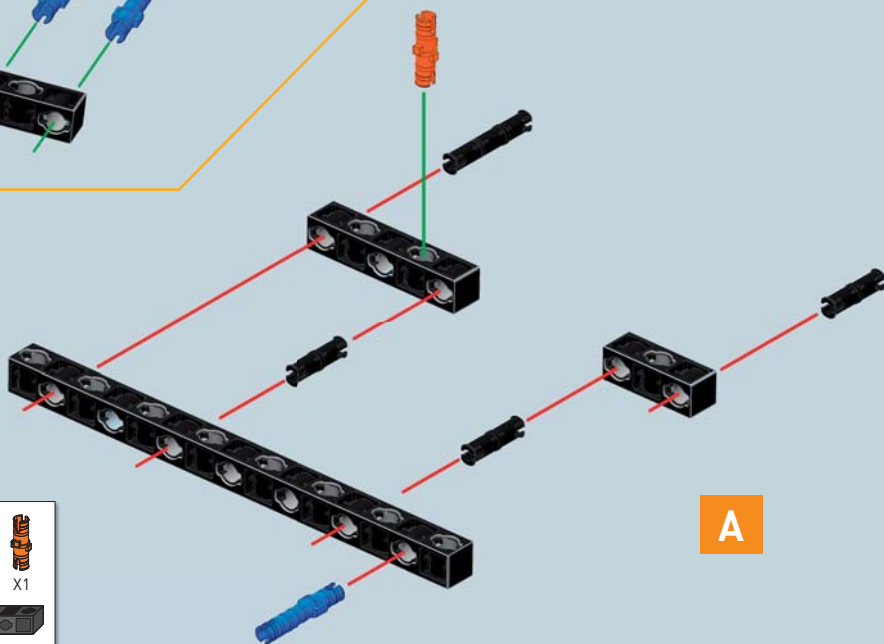

A

3

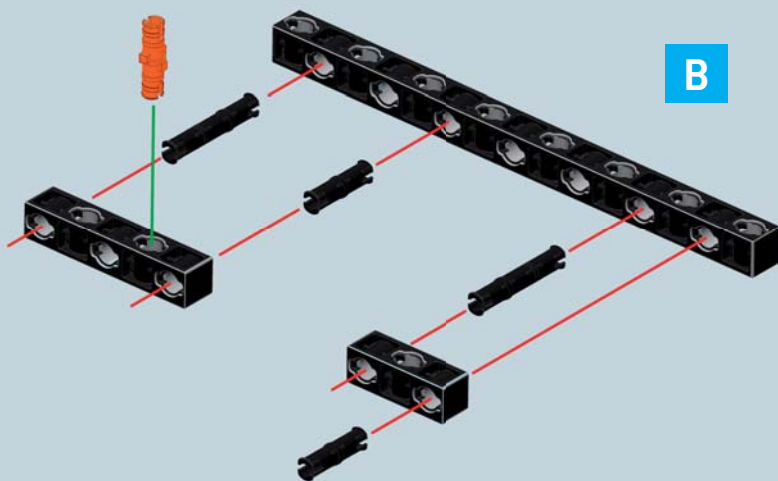

B

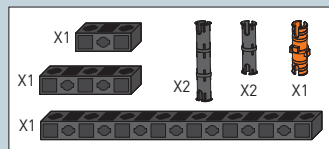

4

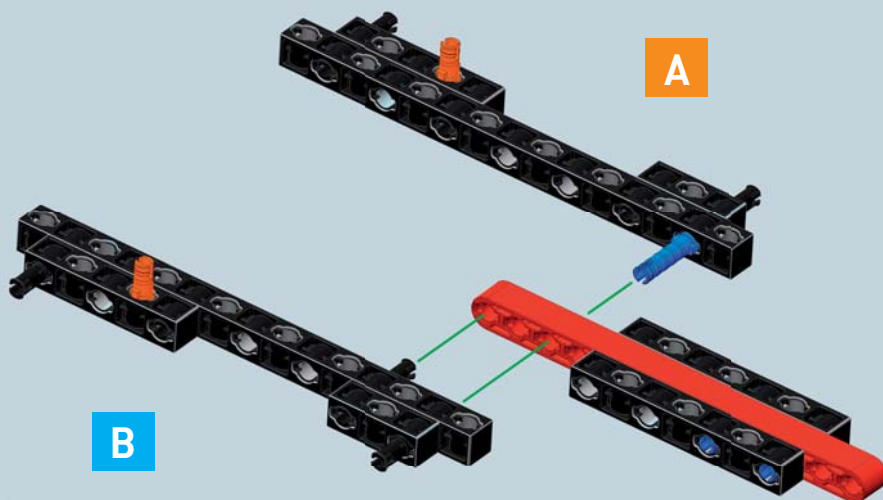

A

B

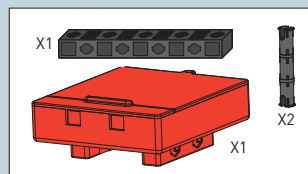

5

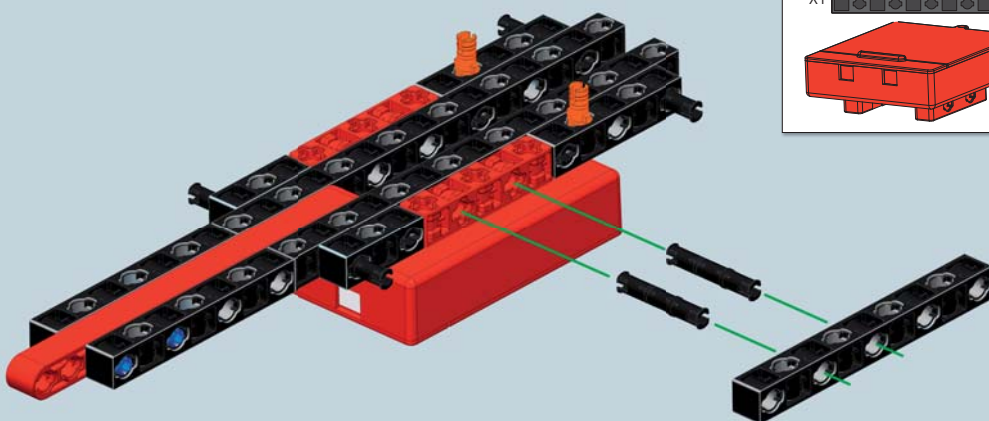

6

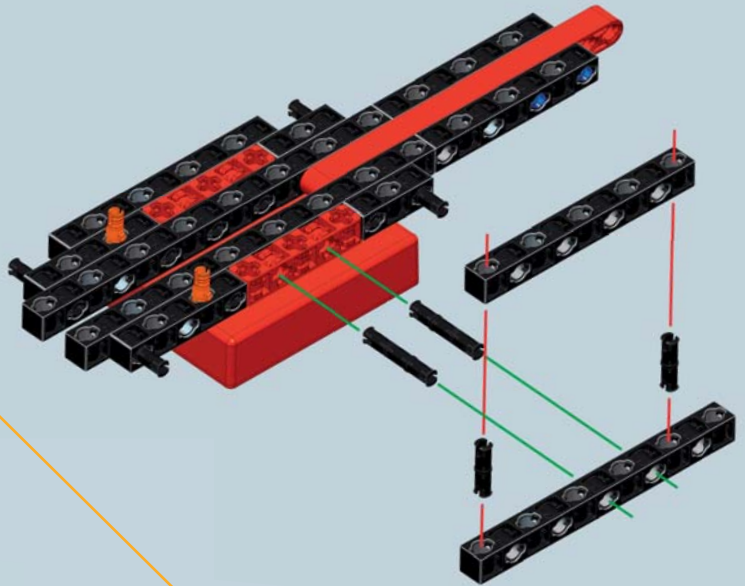
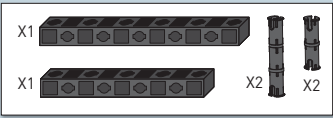

7

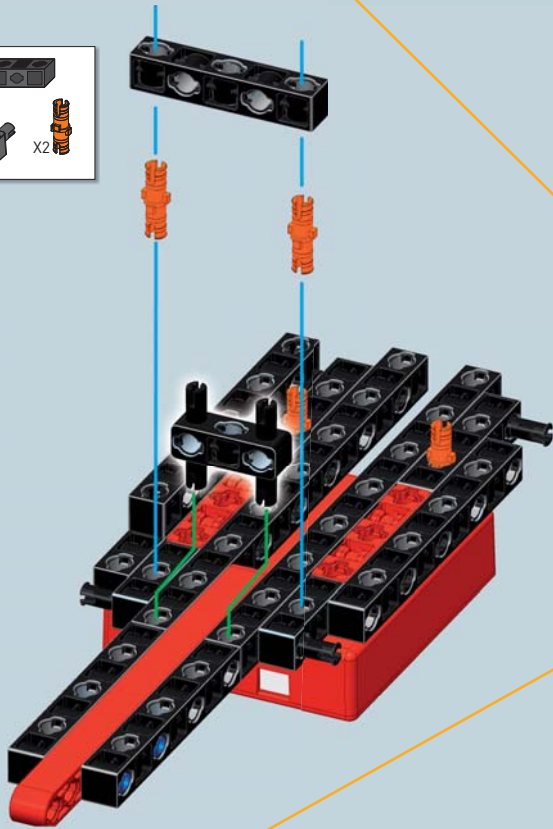
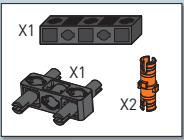

8

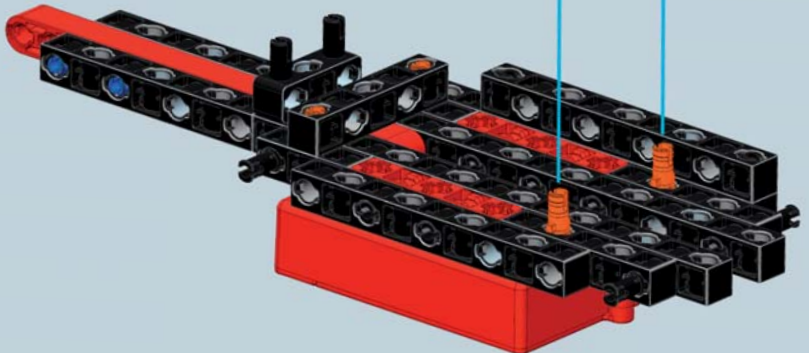
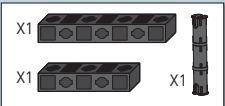

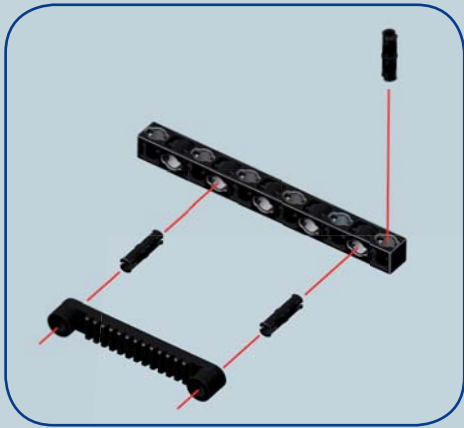

- X1
- X1
- X3

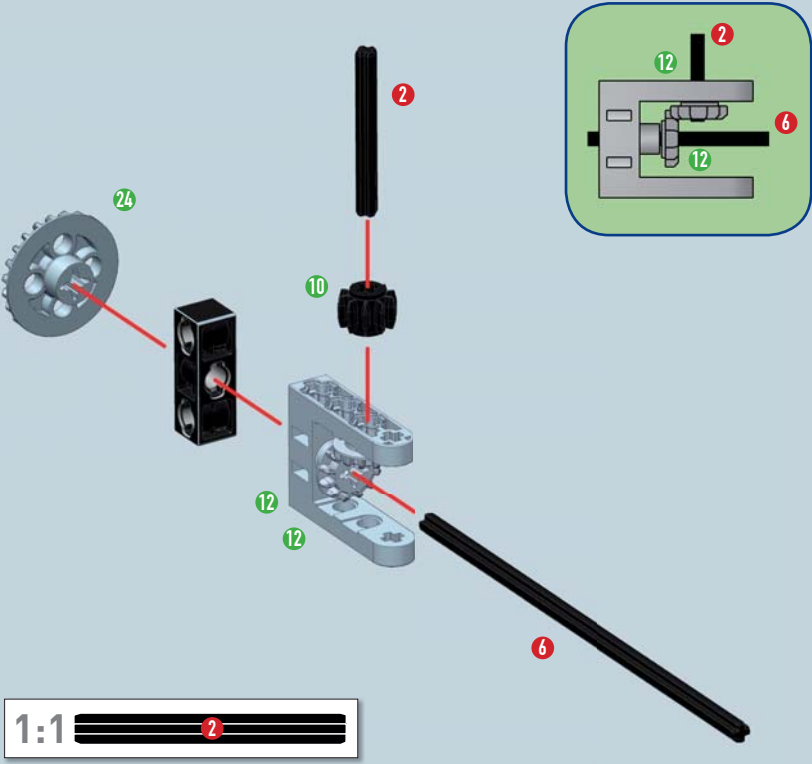
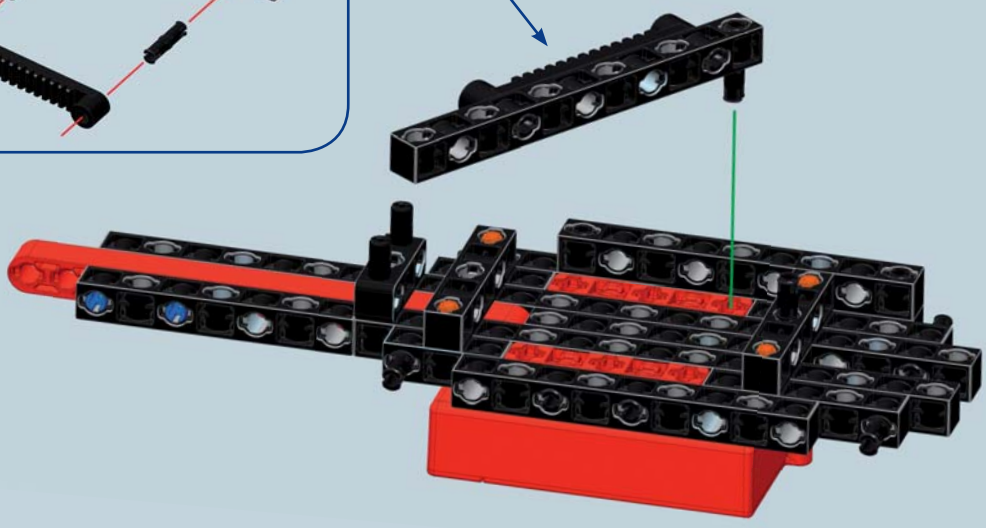

- X1
- X1
- X2
- X1
- X1
- X1

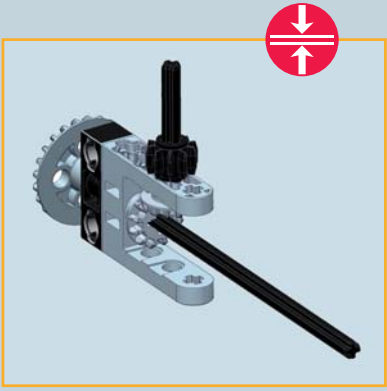

11

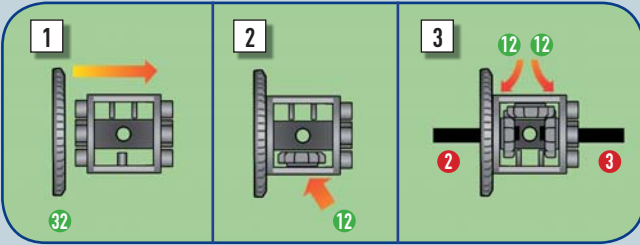
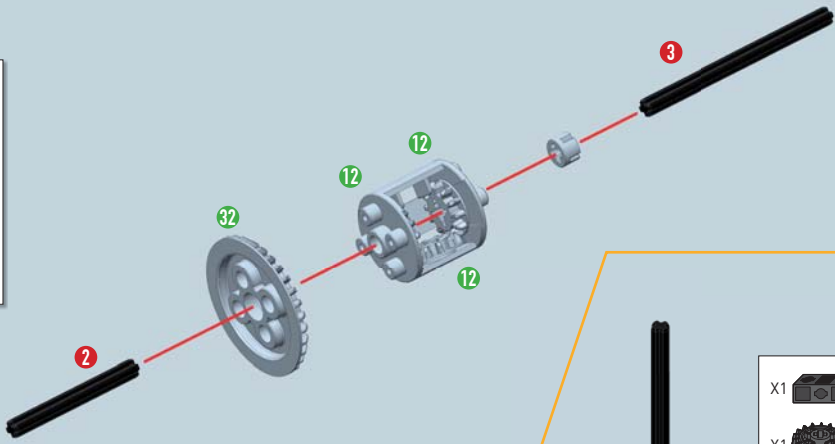
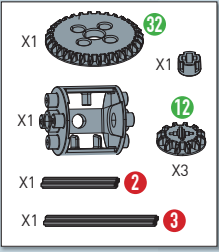

12

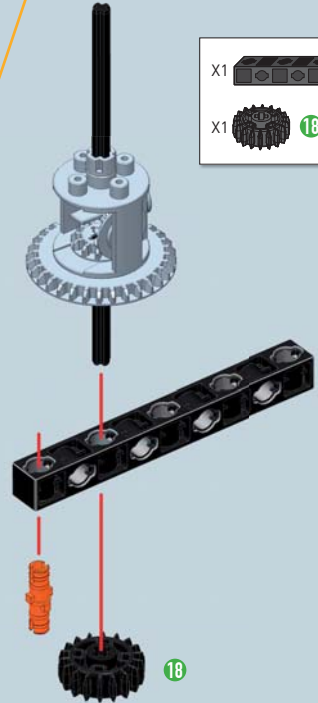
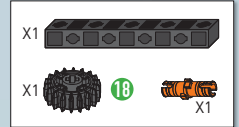

13

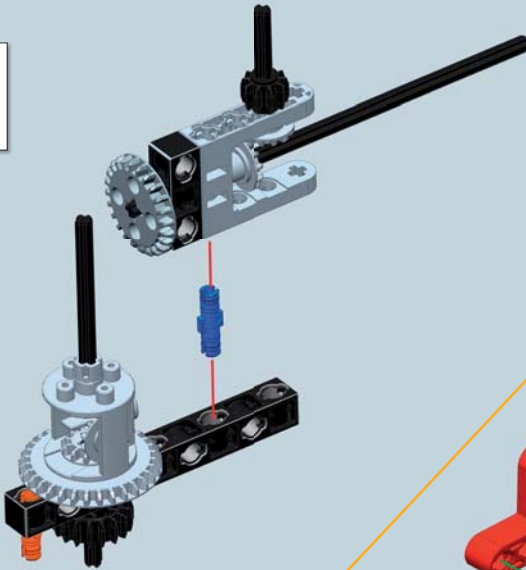

14

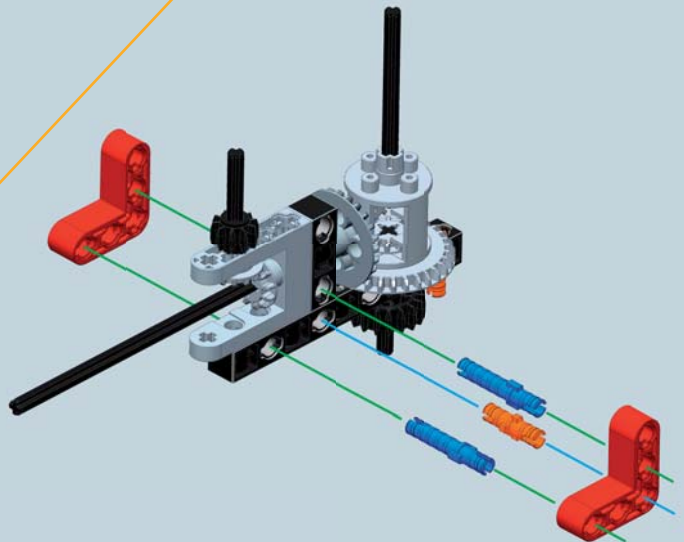
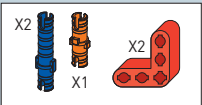

15

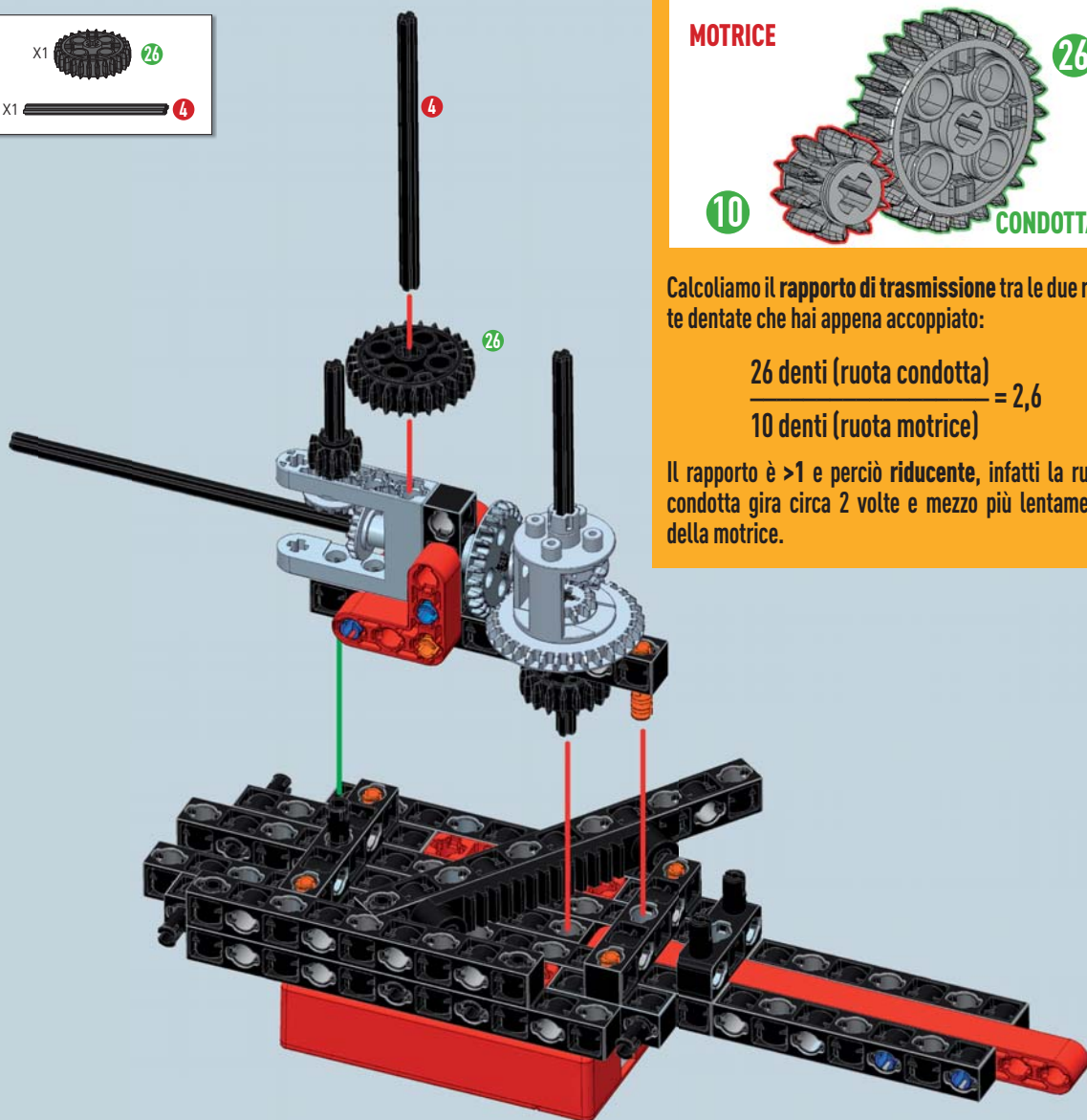
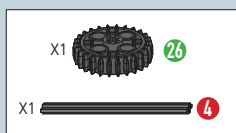

## Rapporto di trasmissione

**MOTRICE**

10

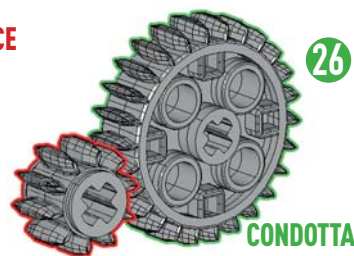

CONDOTTA

Calcoliamo il rapporto di trasmissione tra le due ruote dentate che hai appena accoppiato:

$$\frac{26 \text{ denti (ruota condotta)}}{10 \text{ denti (ruota motrice)}} = 2,6$$

Il rapporto è  $>1$  e perciò **riducente**, infatti la ruota condotta gira circa 2 volte e mezzo più lentamente della motrice.

### Notizie tecniche e curiosità

Anno 1877 - Elicottero senza pilota: A Milano, Enrico Forlanini presenta un congegno che si innalza per circa 15 metri e rimane in aria per 20 secondi.

Anno 1907 - Elicottero con pilota: L'ingegnere francese Paul Cornu, costruisce una macchina con eliche su assi indipendenti, l'elicottero rimane in volo per circa 20 secondi a 30 centimetri da terra.

Anno 1925 - L'inventore olandese Von Baumhauer realizza il primo elicottero con il rotore di coda e con due motori indipendenti.

Anno 1930 - l'ingegnere italiano Corradino D'Ascanio progetta e costruisce un elicottero che il pilota Marinello Nelli, a Roma, tiene in aria per circa dieci minuti, percorre 1 km di distanza ad un'altezza di 20 metri.

1:1

4

16

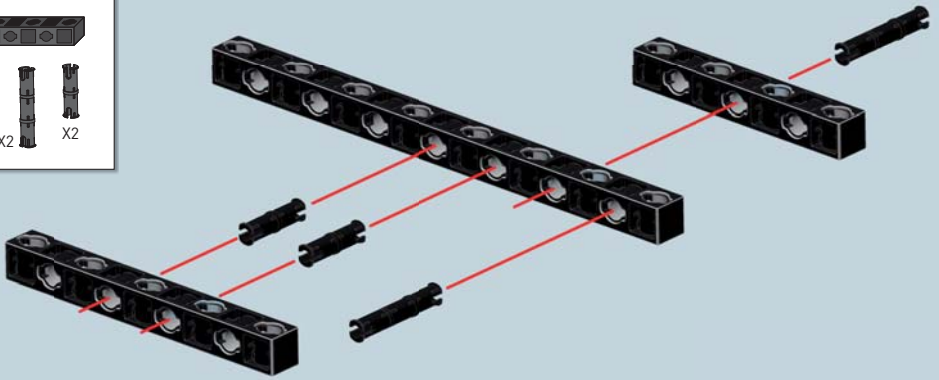
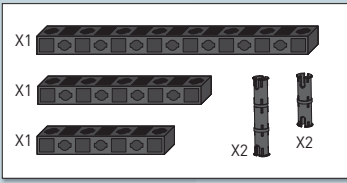

A

17

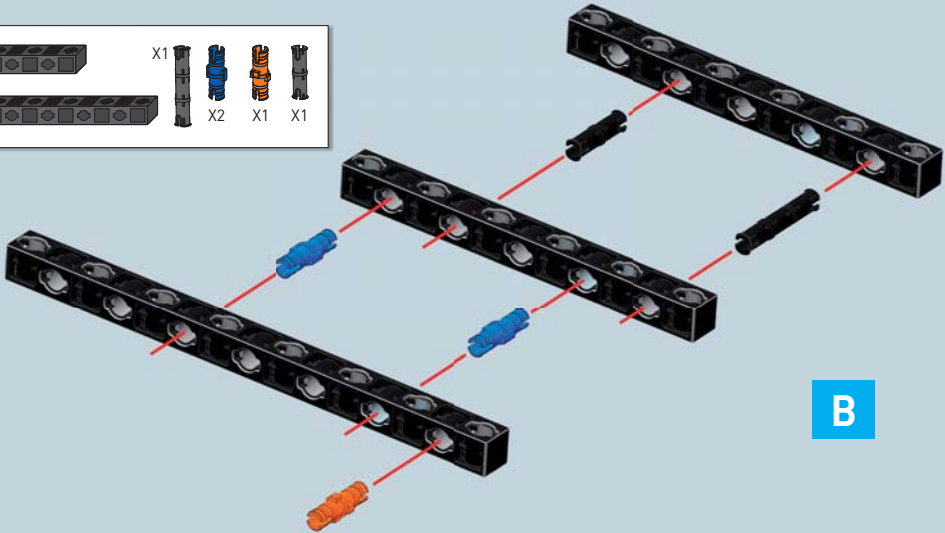
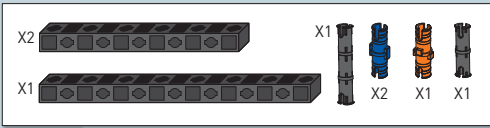

B

18

A

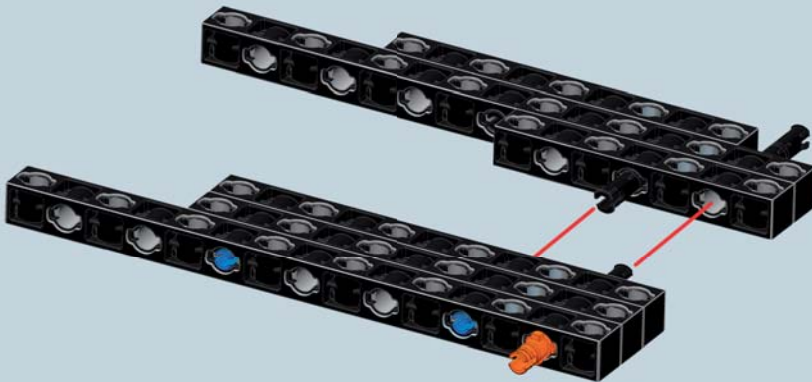

B



19

- X1 
- X2 

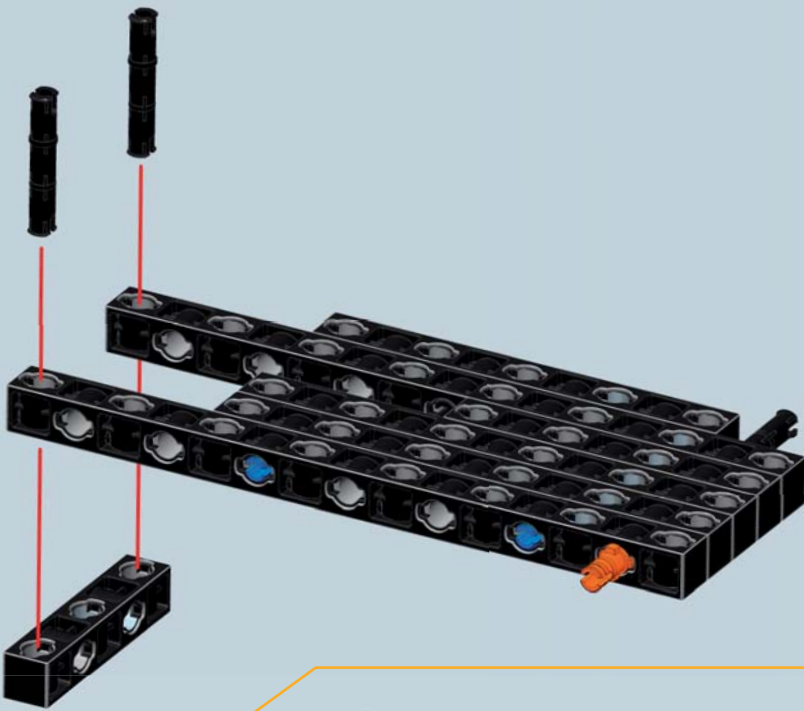

20

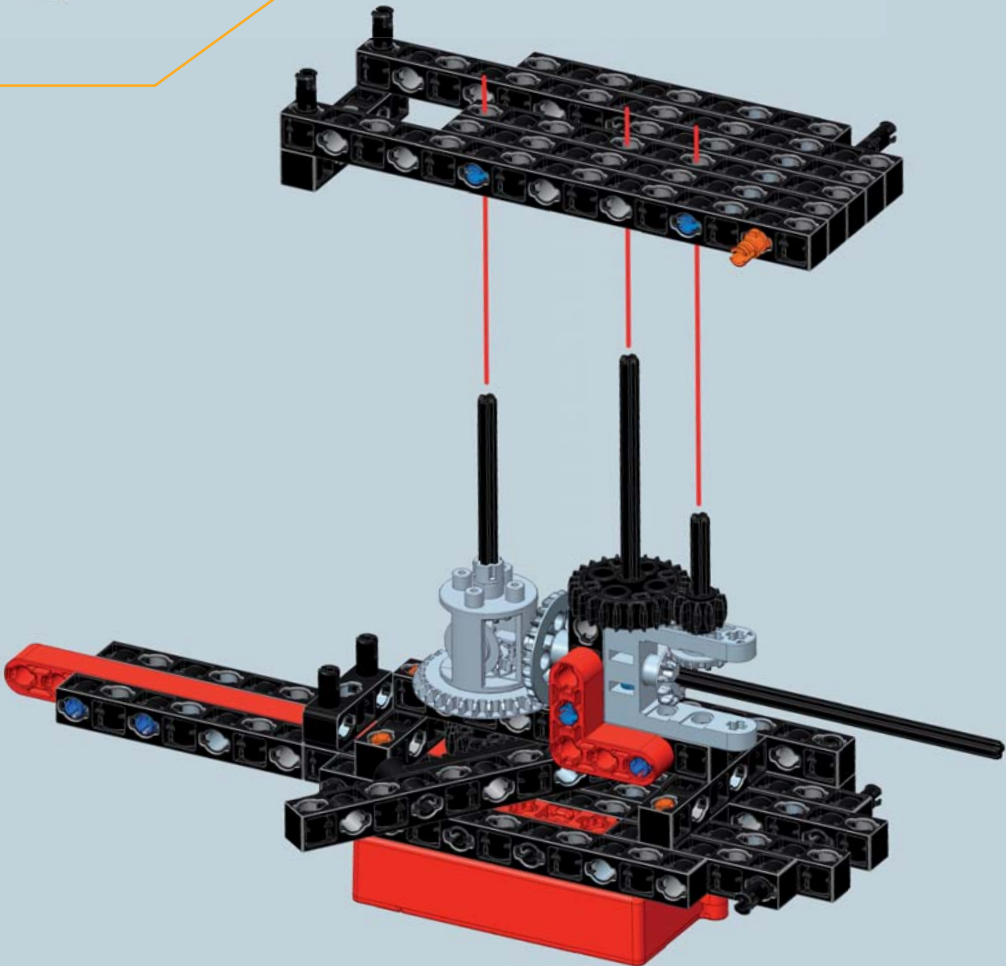

21

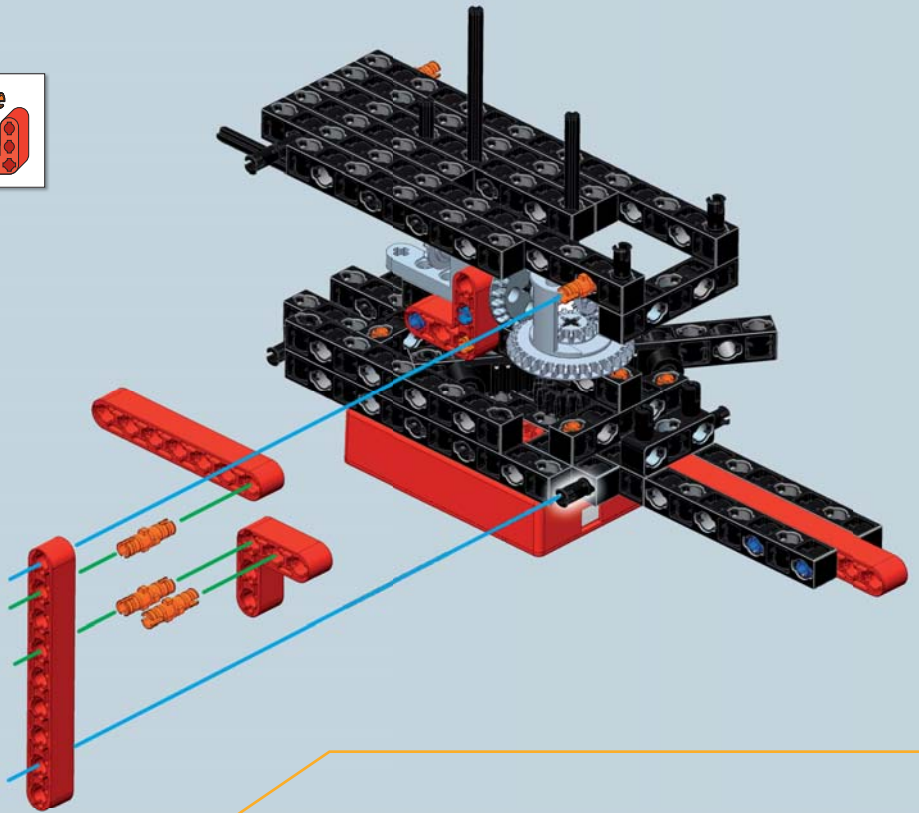
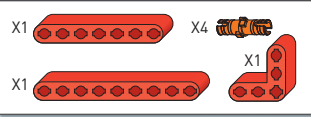

22

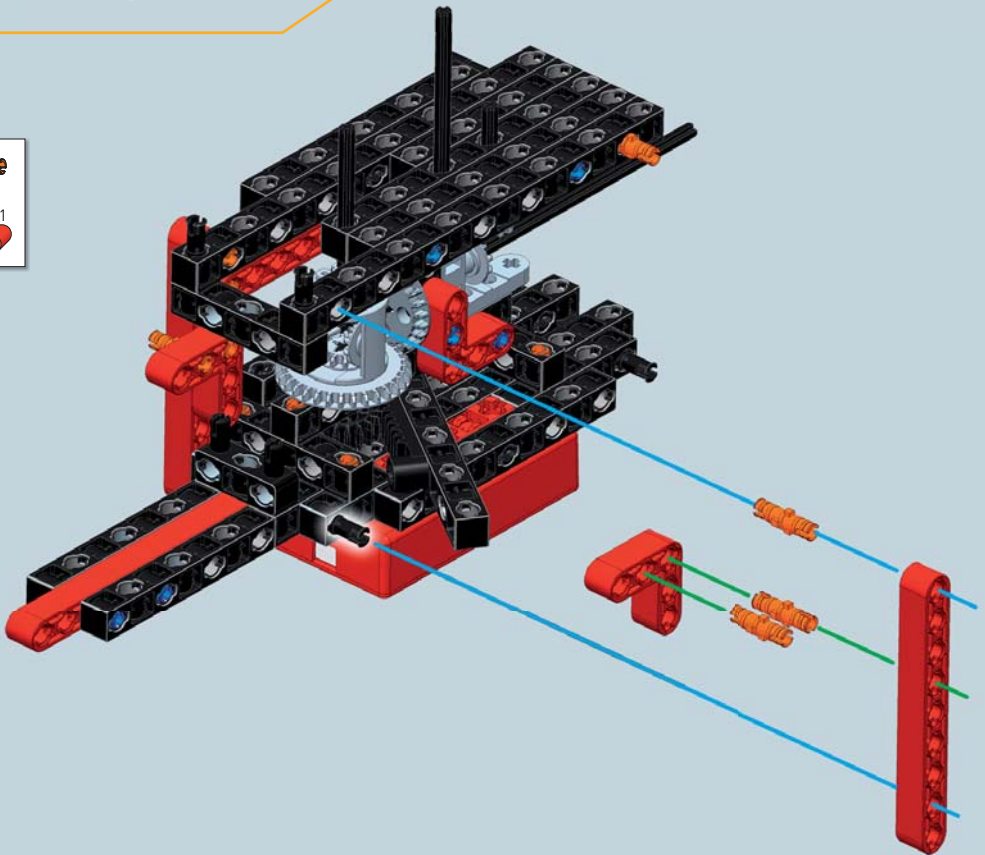
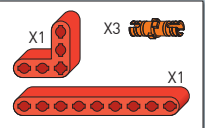

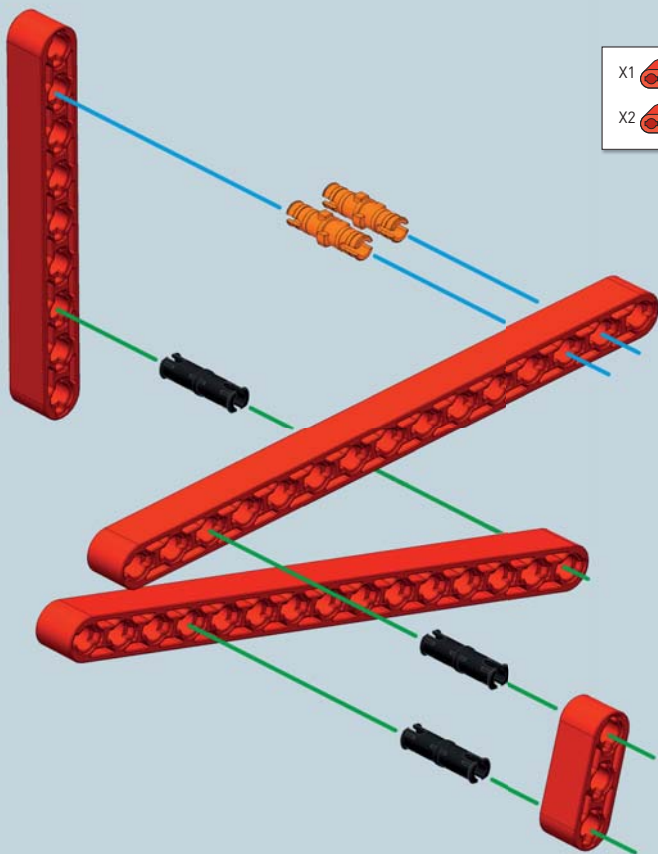

X1		X1			
X2				X2	X3

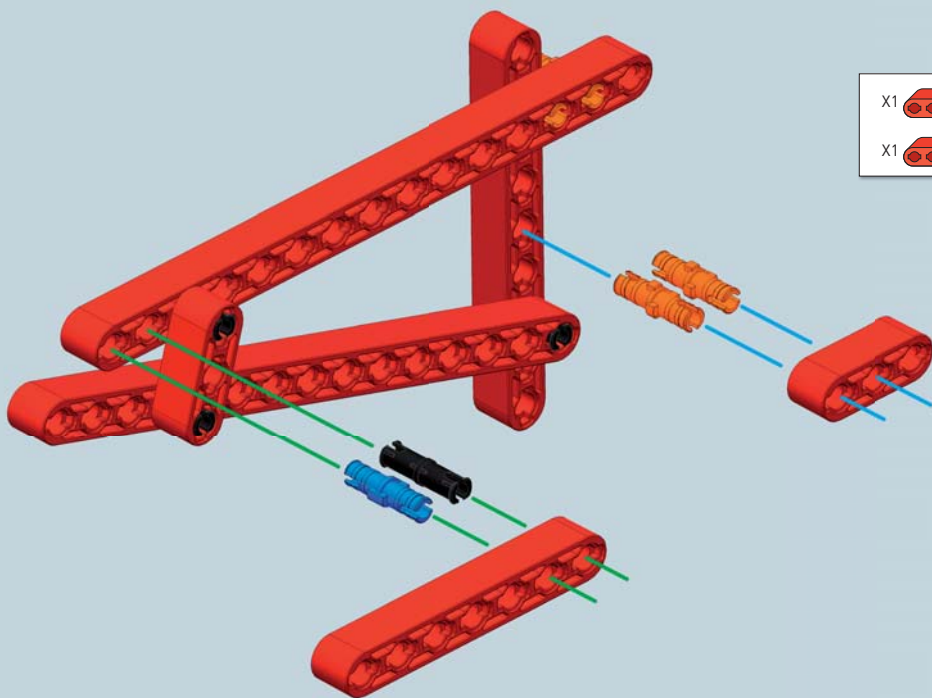

X1				
X1		X2	X1	X1

25

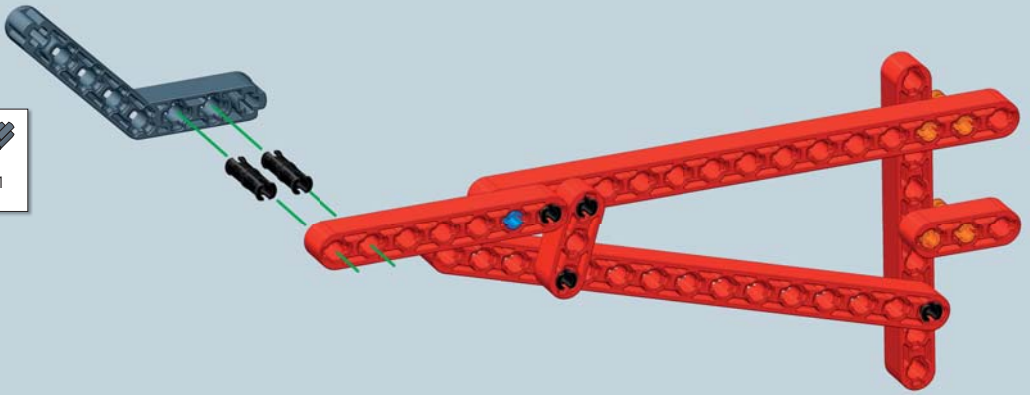
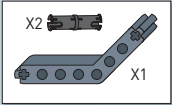

26

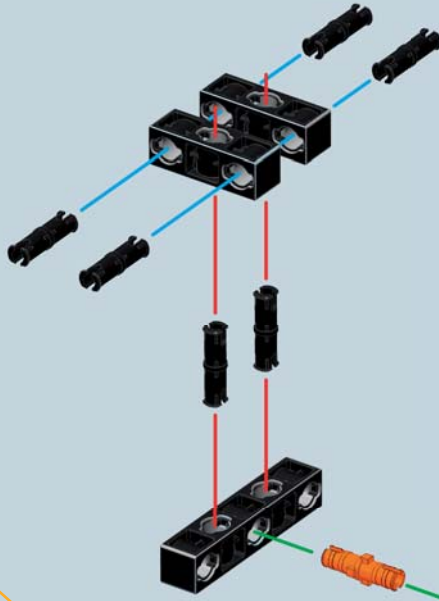
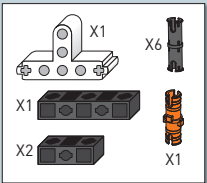

27

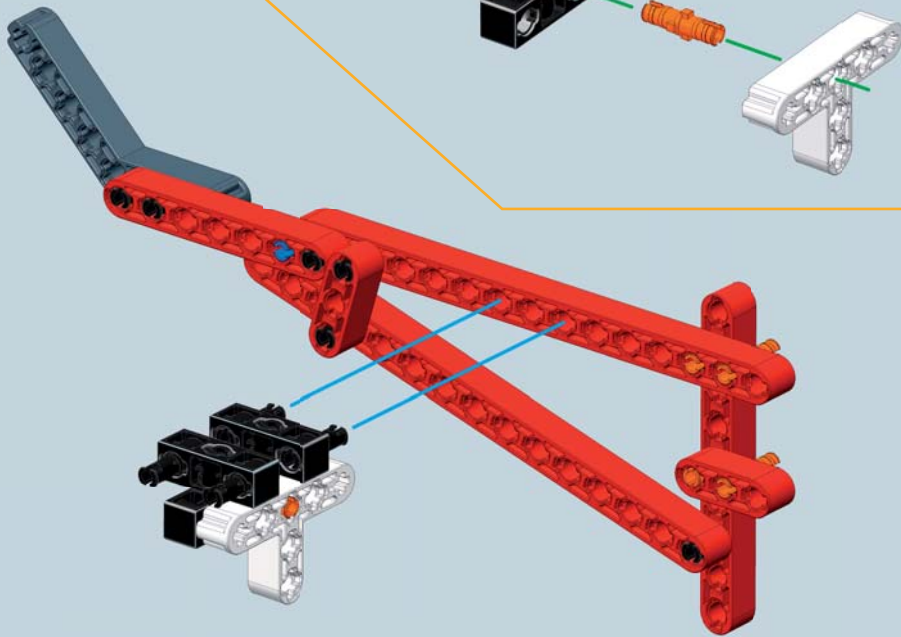

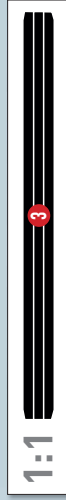
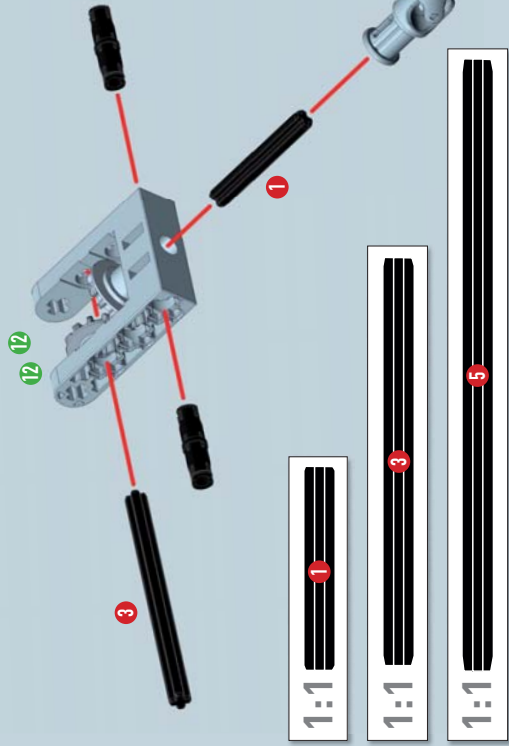
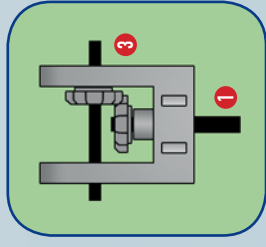
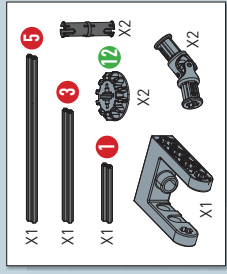
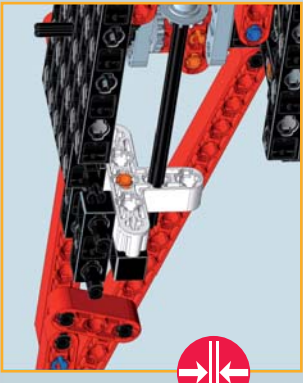
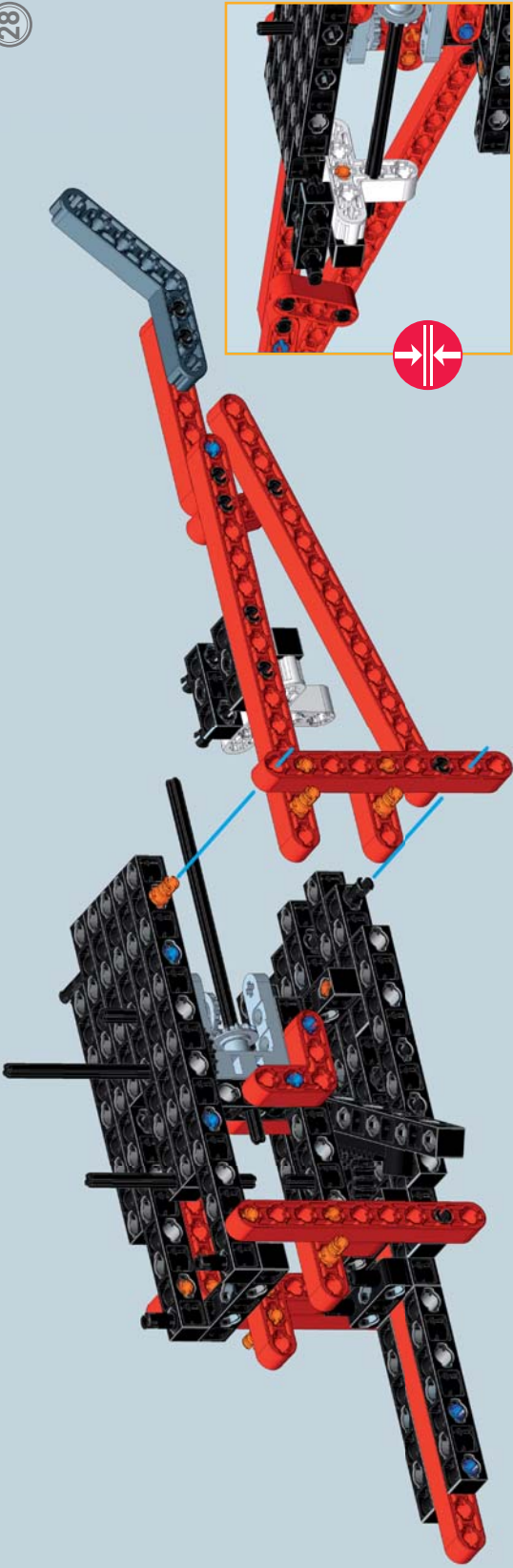

Per assemblare il giunto cardanico  
segui le indicazioni stampate sul  
foglio delle avvertenze



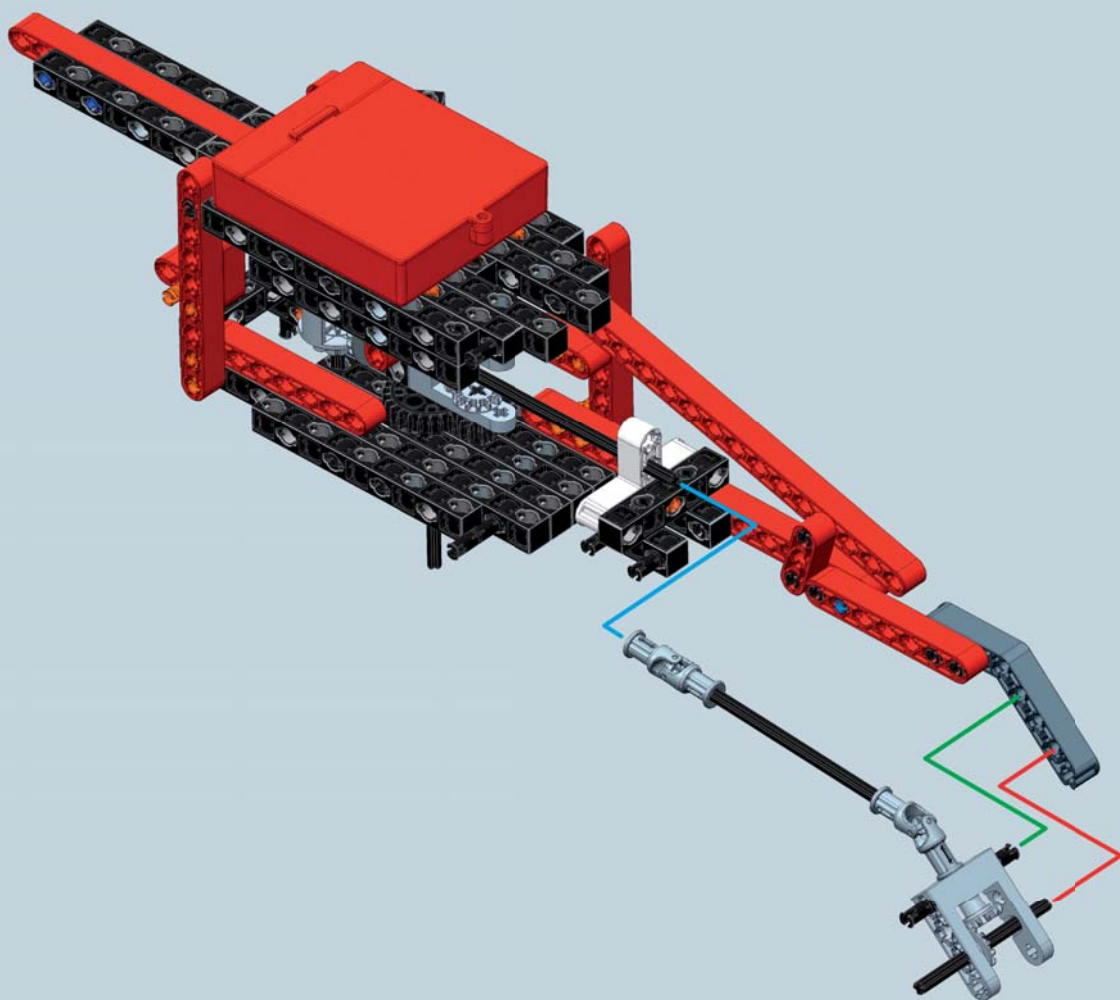

A



B



### Notizie tecniche e curiosità

Negli elicotteri la trasmissione del moto al rotore di coda avviene tramite un **albero di trasmissione**, che può essere unico o suddiviso in più parti unite da giunti flessibili. Esistono due tipi di rotore di coda: il **rotore convenzionale (A)**, con le pale che sporgono all'esterno del telaio; il **rotore intubato (B)**, in cui le pale sono fatte ruotare in una cavità ricavata nella coda dell'elicottero. Tra i vantaggi del rotore intubato c'è sicuramente una maggiore sicurezza per l'equipaggio e una aumentata velocità del mezzo stesso. Il modello che stai costruendo monta un rotore convenzionale.

X2				
X1			X1	X3

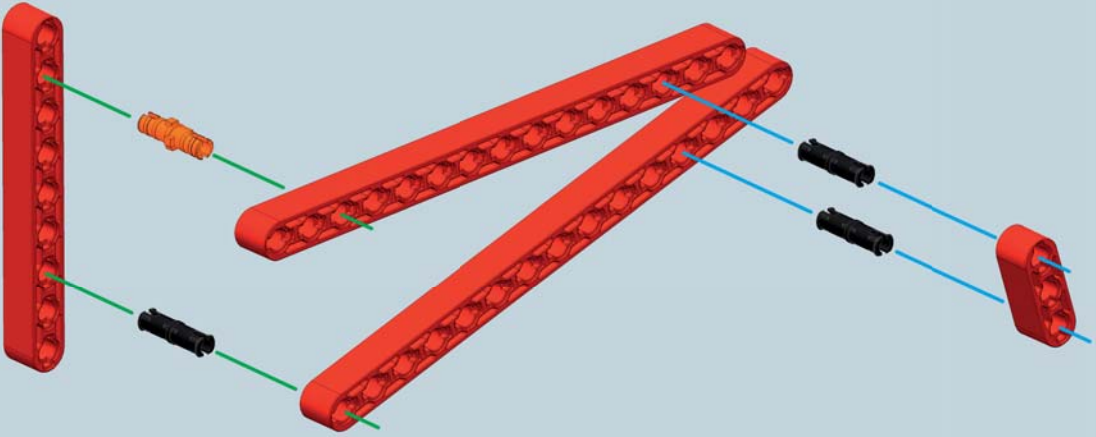

X1		
X3		X1

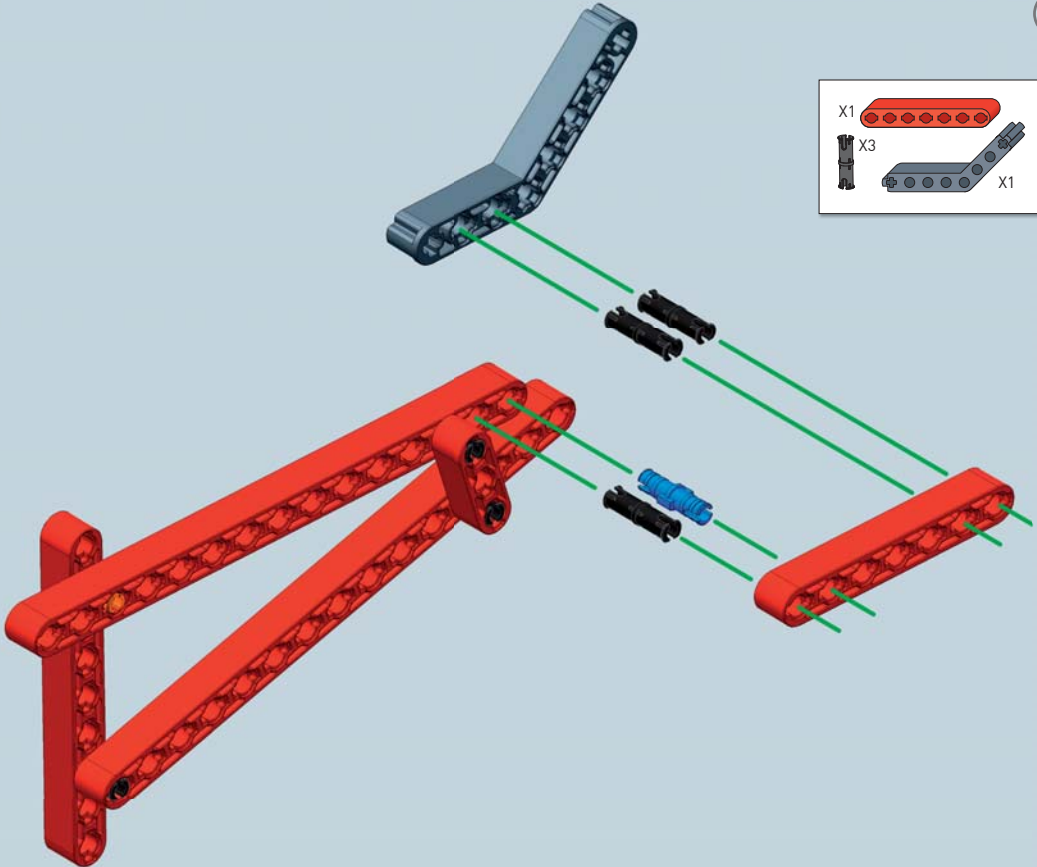

33

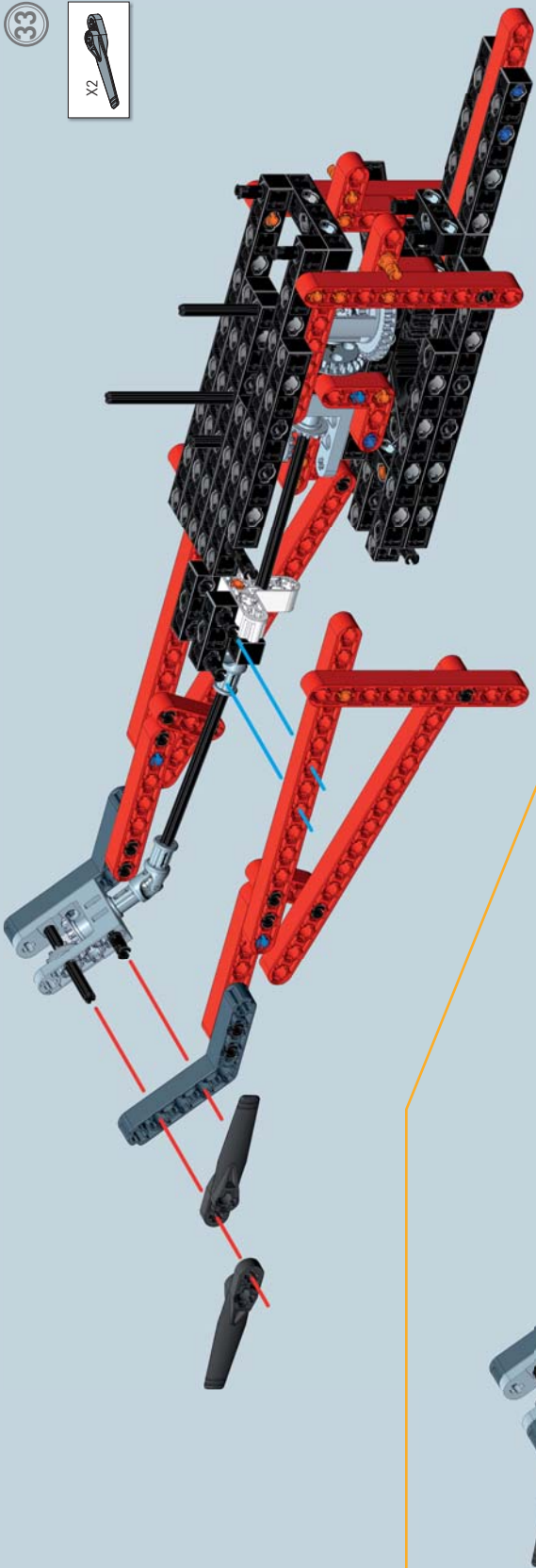

34

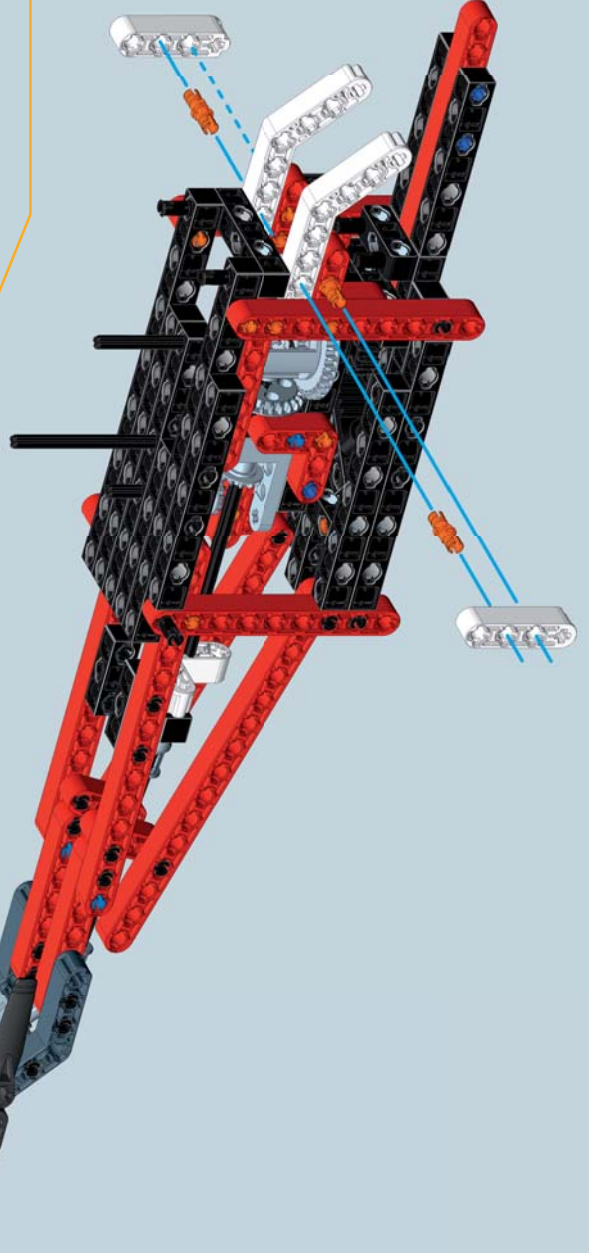
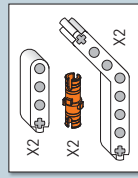



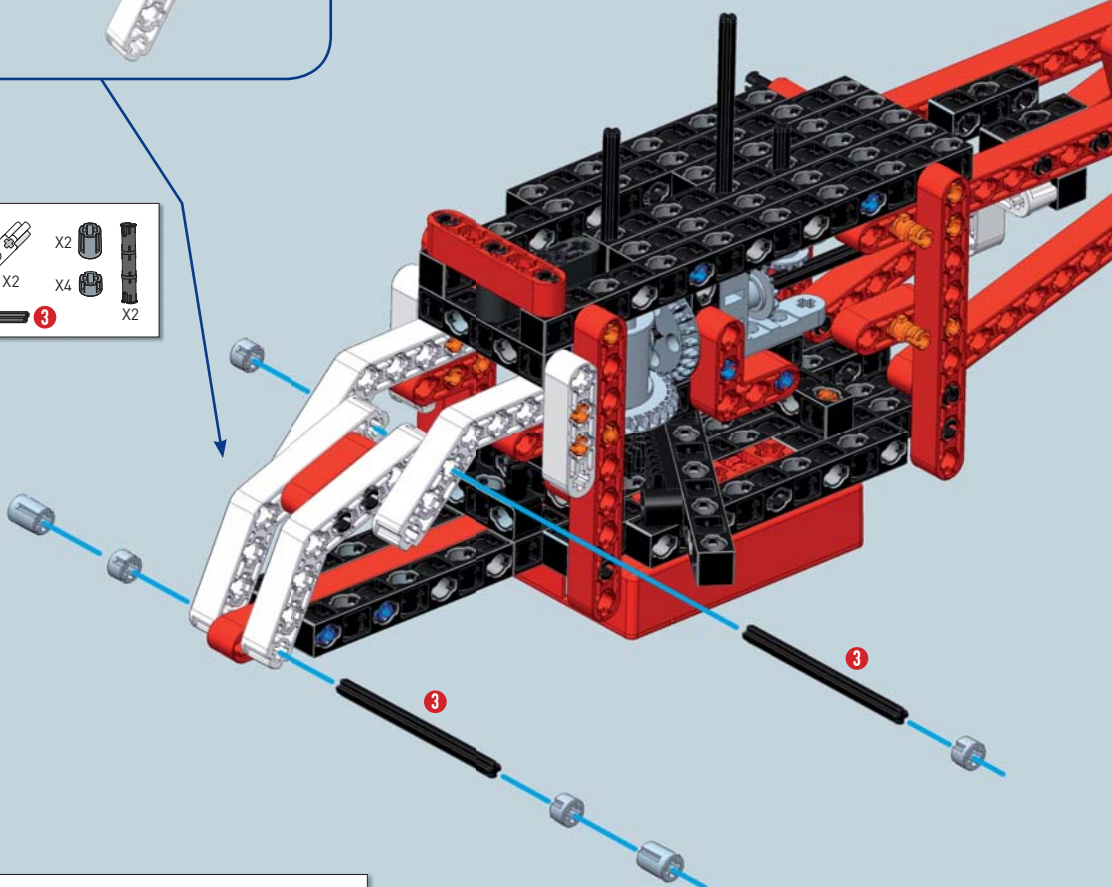
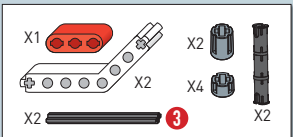
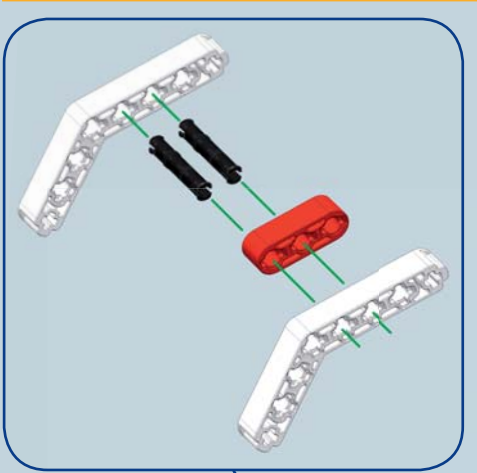
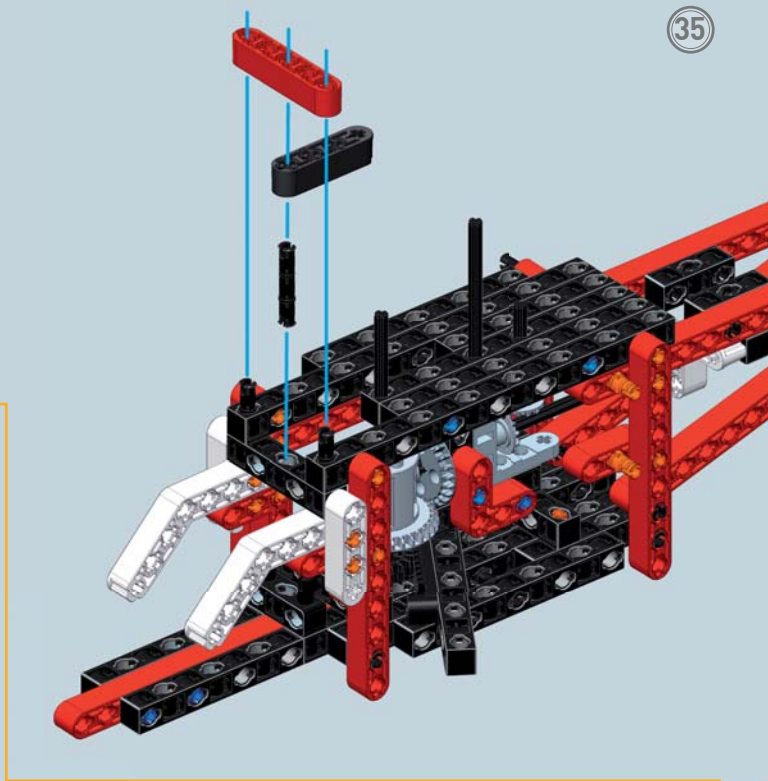
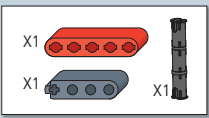

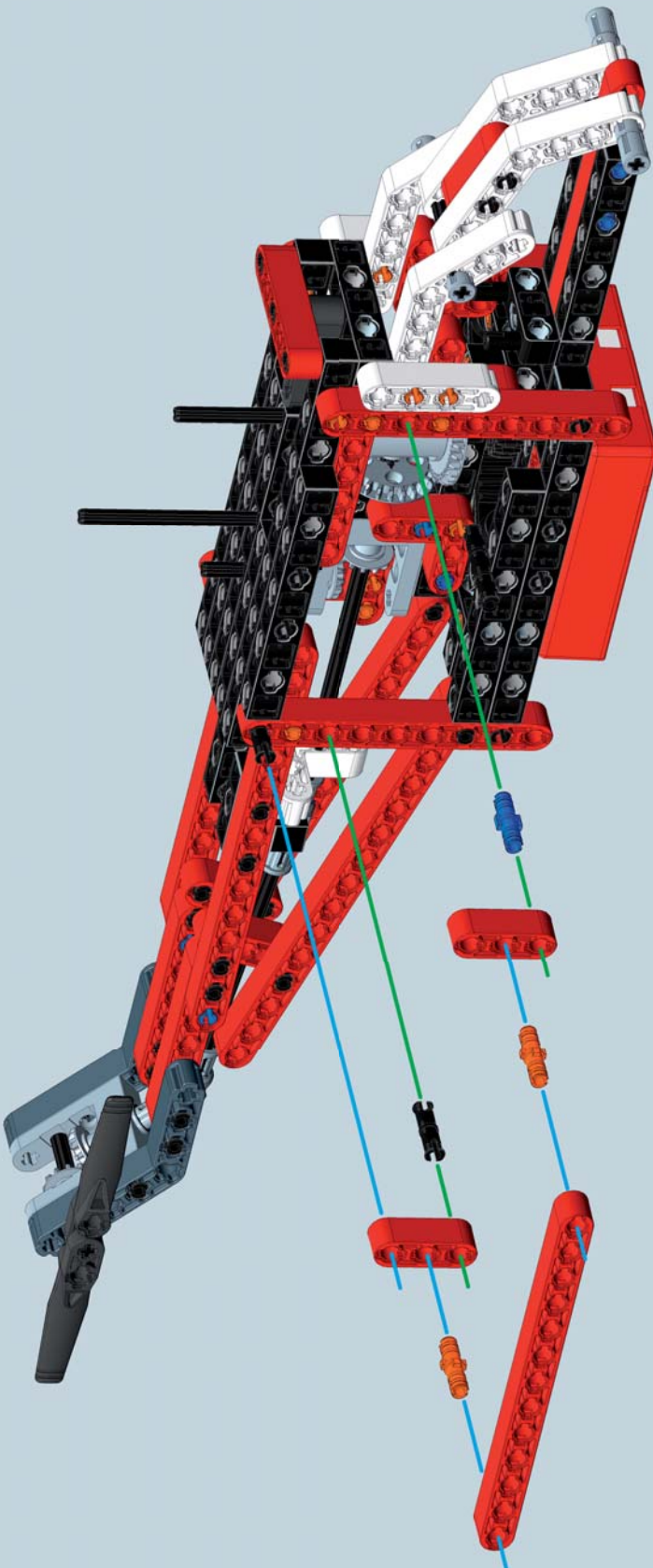
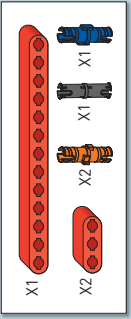

38

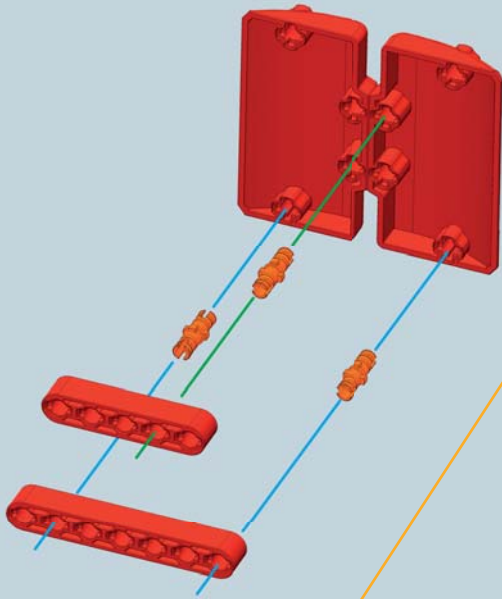
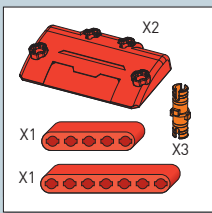

39

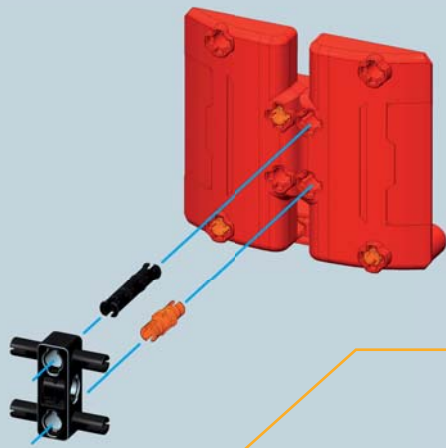
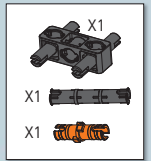

40

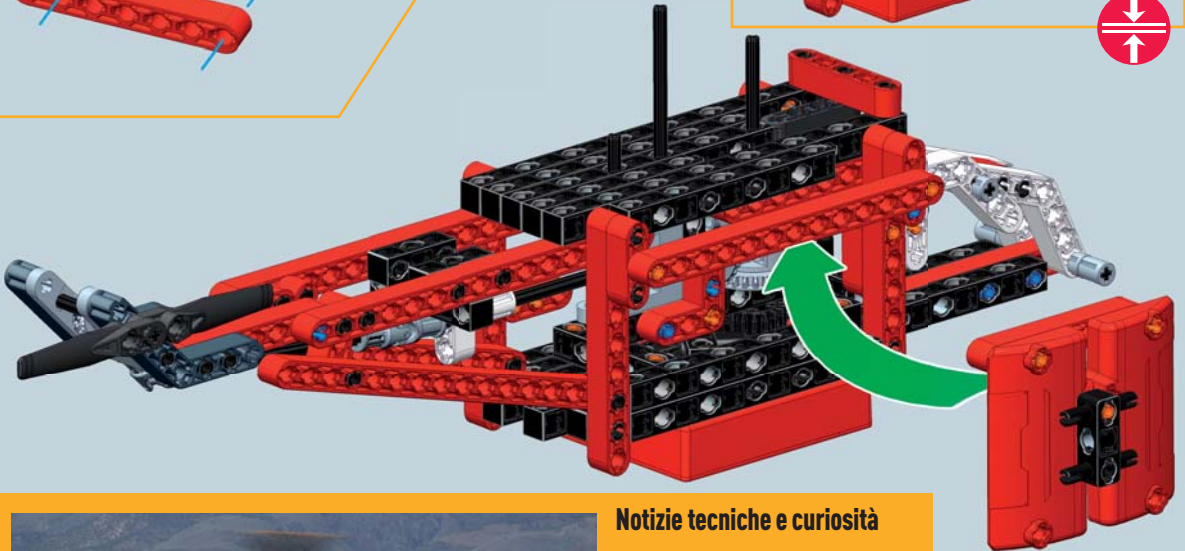
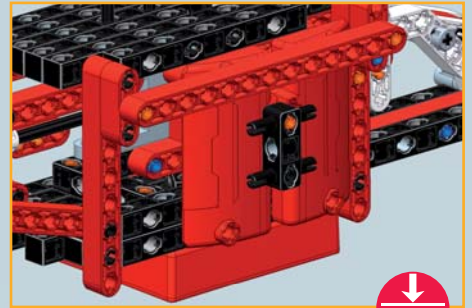

### Notizie tecniche e curiosità

L'ampio portellone scorrevole permette all'equipaggio un rapido accesso al luogo dell'incidente e il carico di barelle per il trasporto dei feriti. Nel caso di interventi con verricello l'equipaggio è solitamente composto da: comandante pilota, tecnico verricellista, tecnico dell'elisoccorso e personale medico.



41

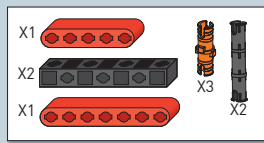
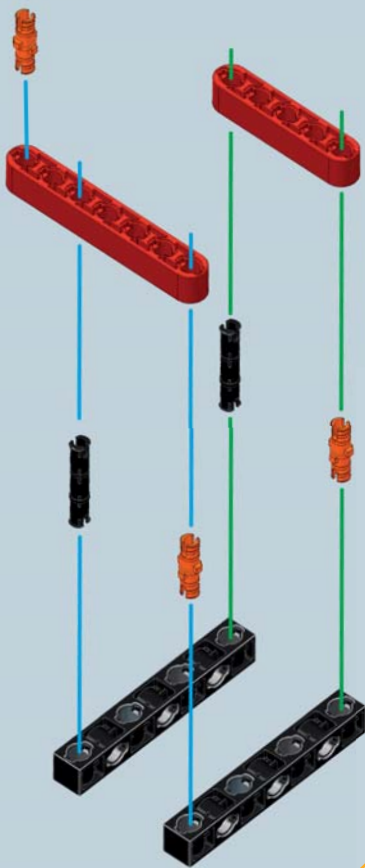

42

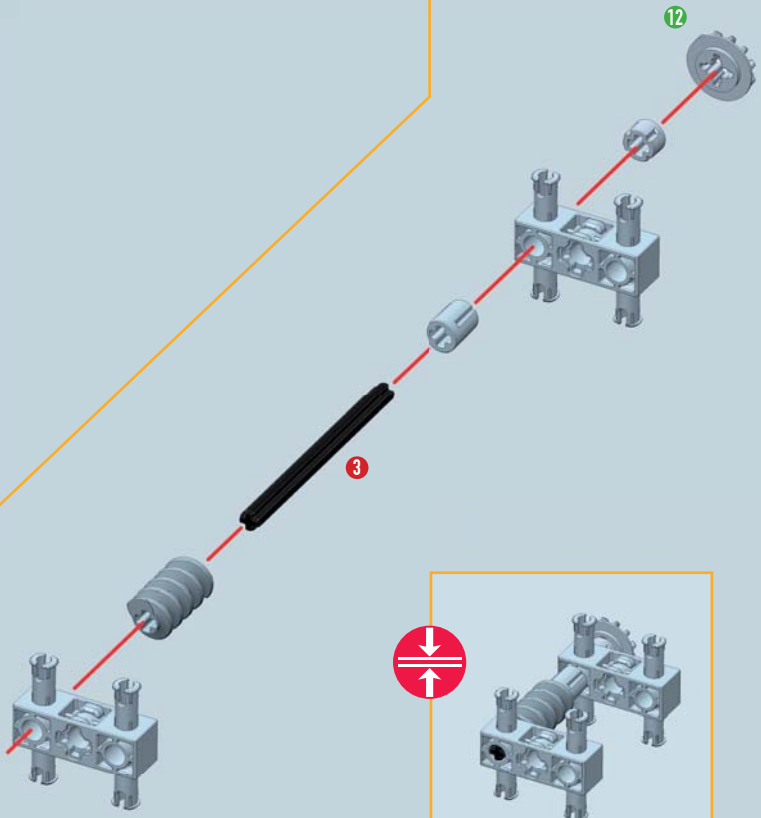
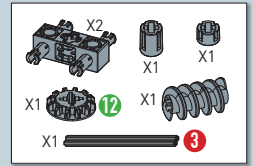

43

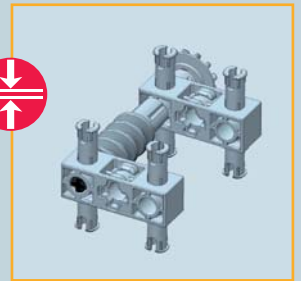
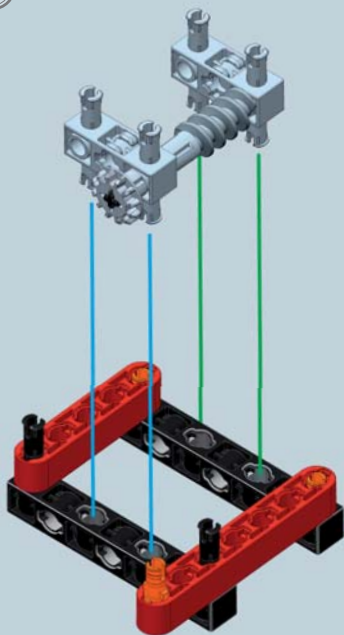

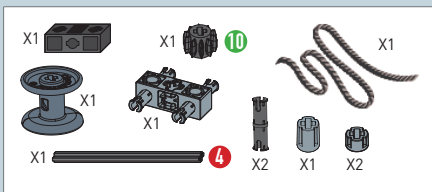

**Lega il filo al rocchetto**

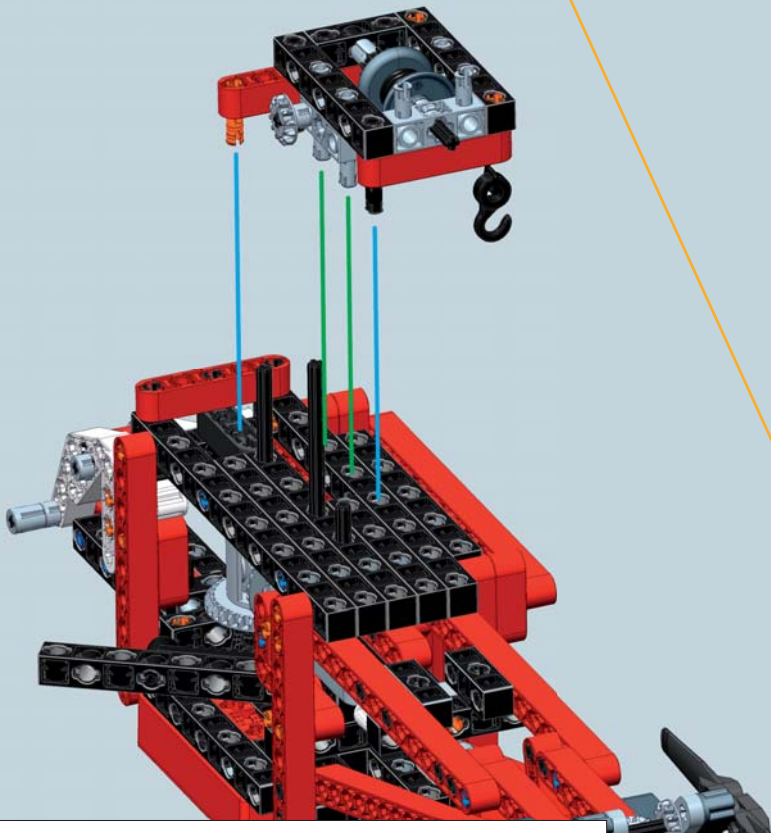
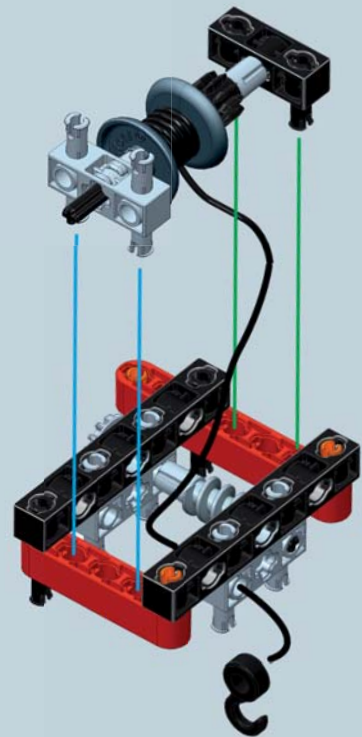
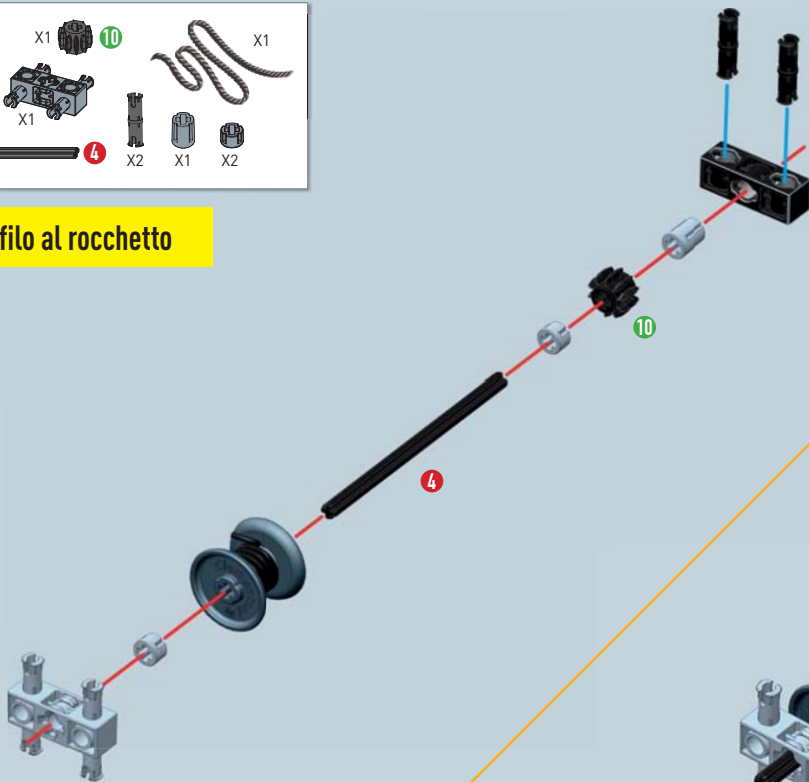



## Notizie tecniche e curiosità

Nelle situazioni in cui l'ambiente non rende possibile l'atterraggio, il recupero dei feriti viene operato tramite verricello. Il verricello è una macchina semplice: è costituito da un cilindro orizzontale, detto tamburo, attorno al quale viene avvolta una fune collegata al carico da sollevare. Per l'elisoccorso la fune è di acciaio e può sollevare fino a 270 kg. La potenza viene applicata da un motore elettrico connesso al tamburo.

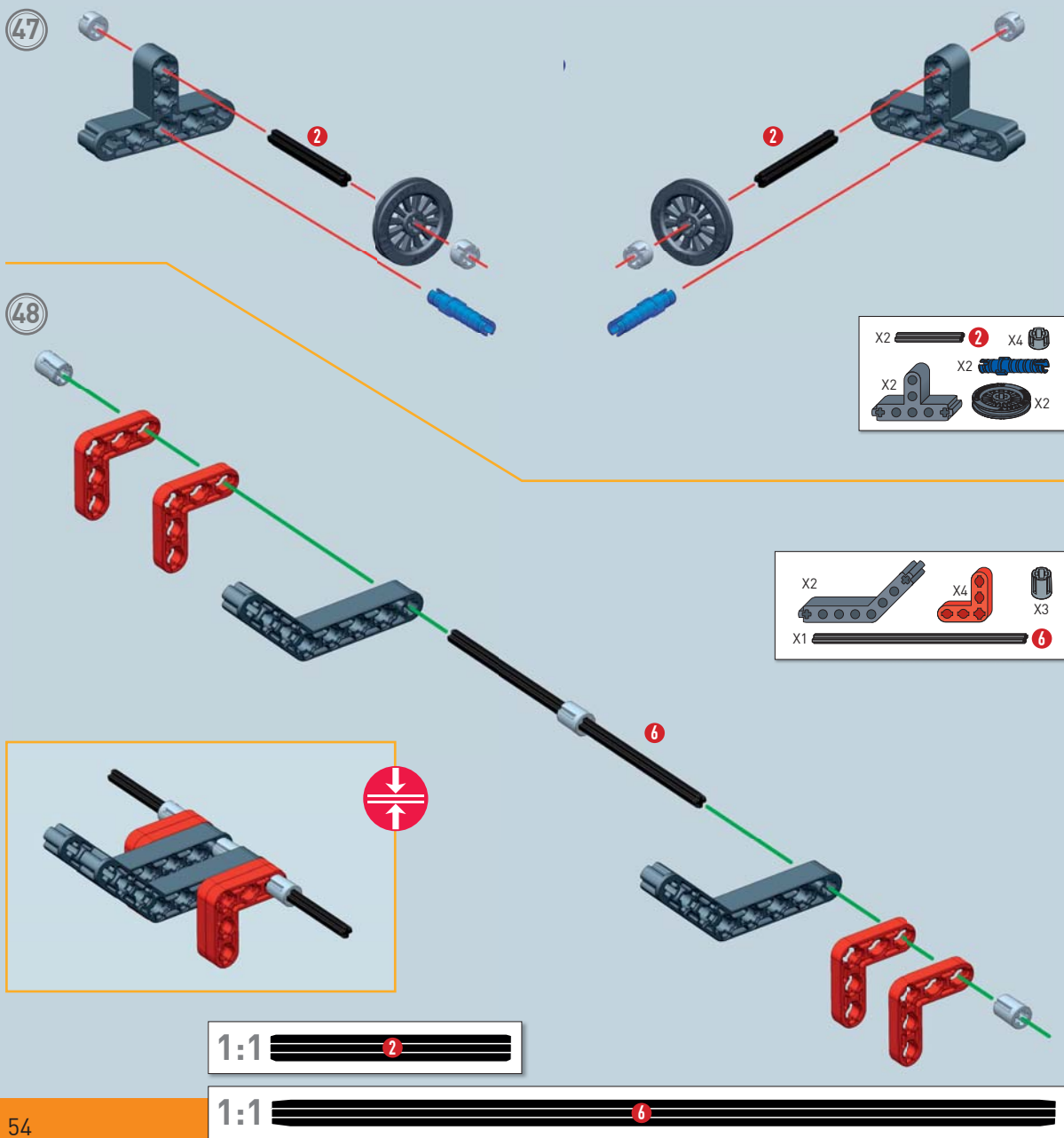

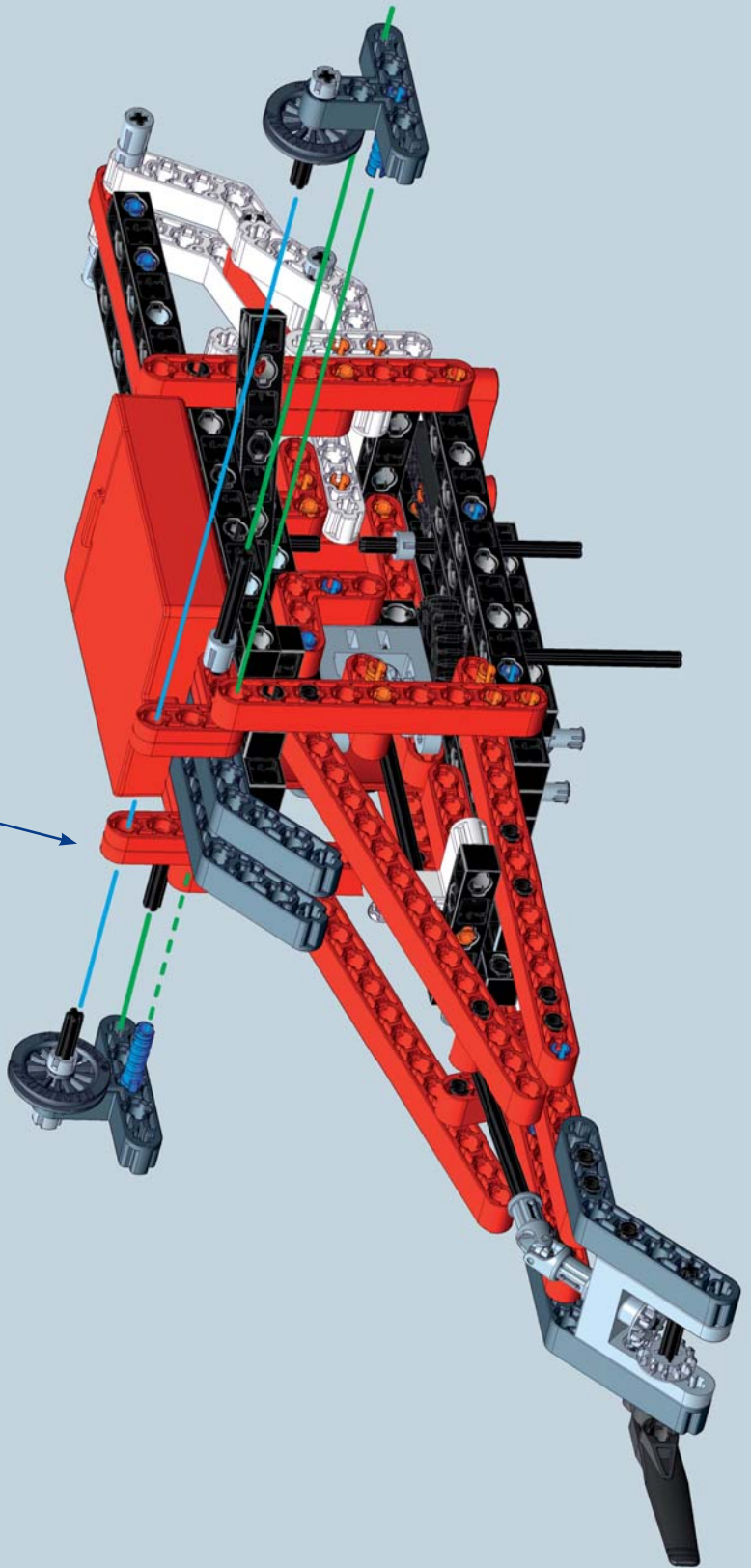
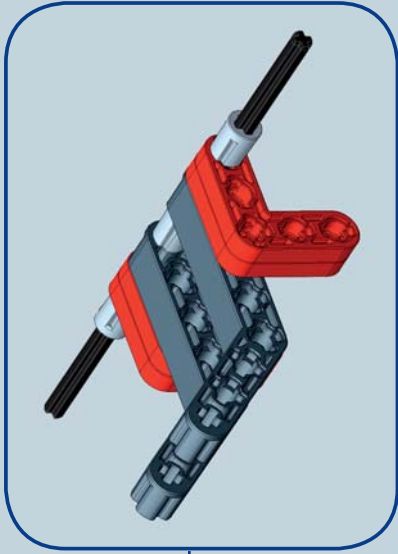

50

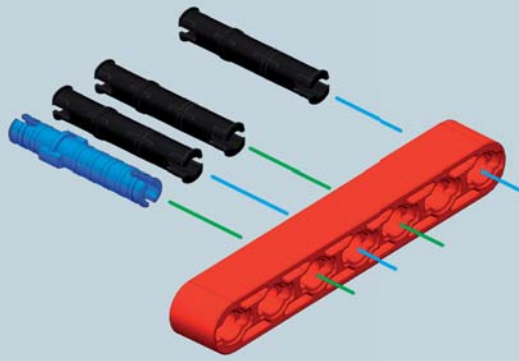
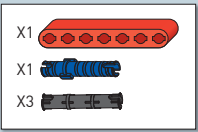

51

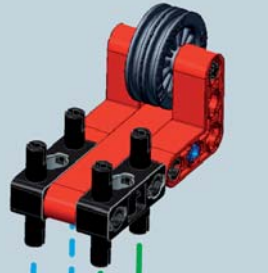
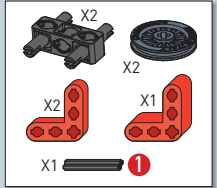
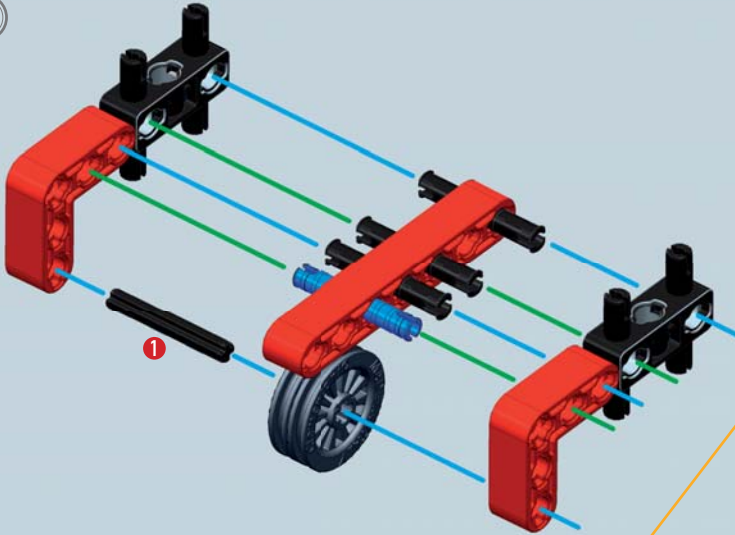

52

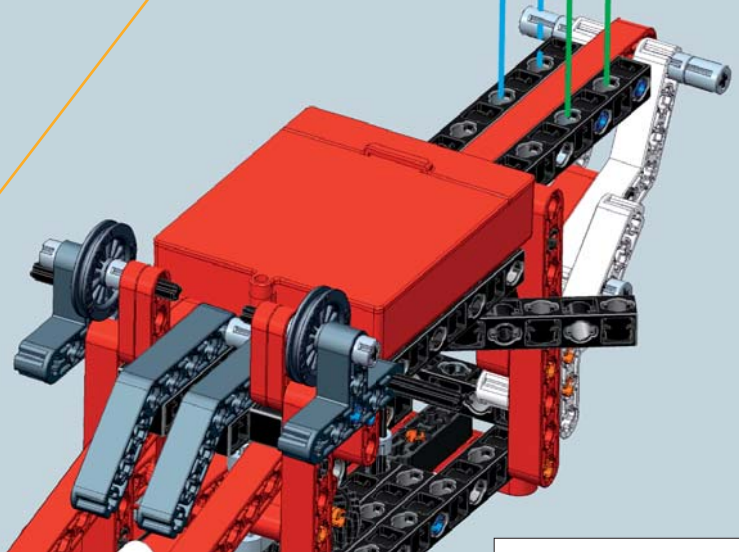



53

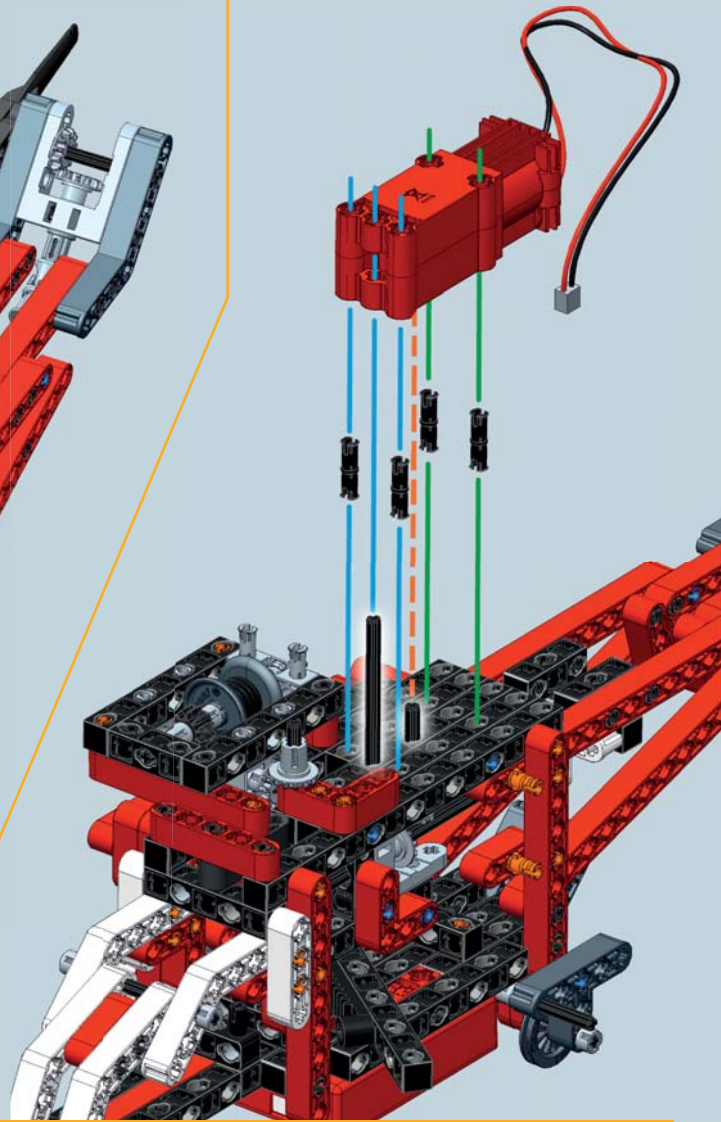
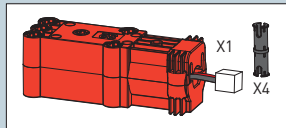
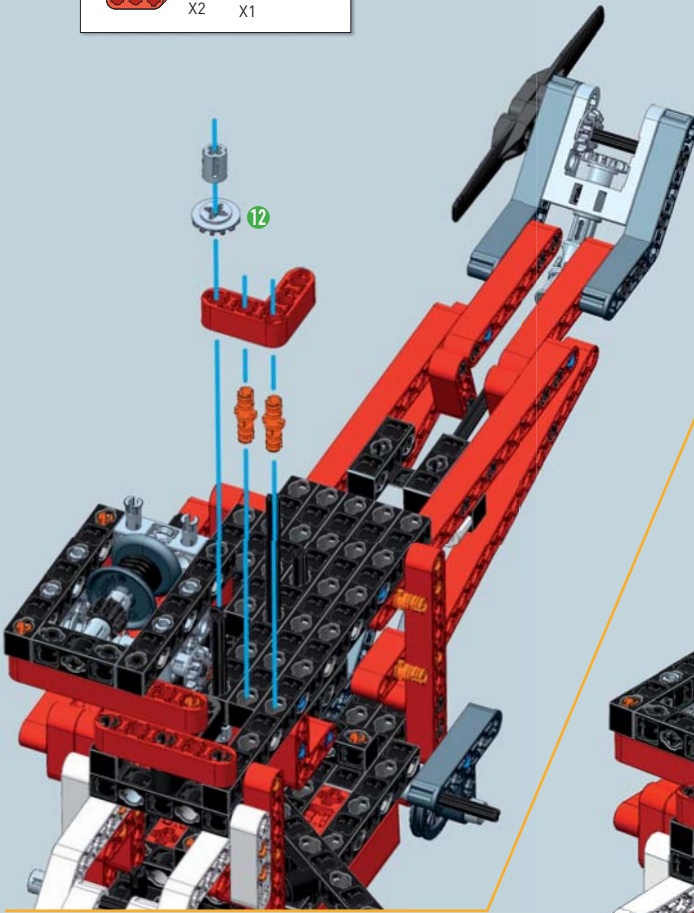
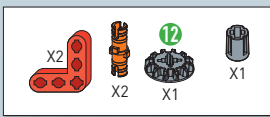

54

### Notizie tecniche e curiosità

Il motore più utilizzato negli elicotteri è il motore **turboalbero** che, come il motore a **combustione interna**, trasforma l'energia chimica in potenza meccanica (vedi pag. 13). L'aria viene risucchiata dal sistema di compressione verso la camera di combustione, dove, mescolata al combustibile, produce lo scoppio. L'energia della combustione mette in movimento un albero di trasmissione che trasferisce la rotazione alle pale.

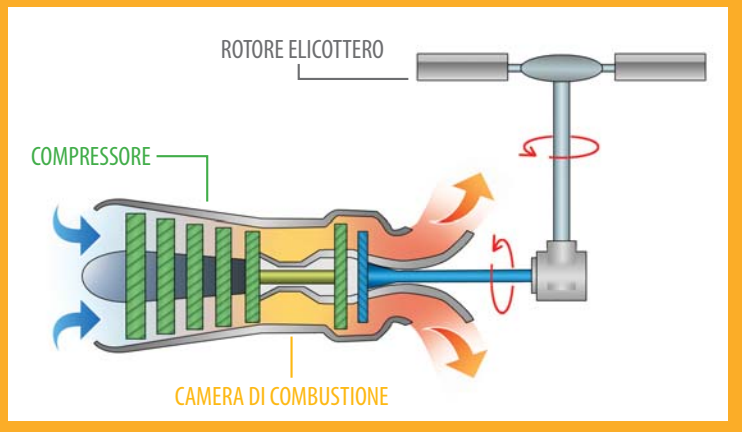

55

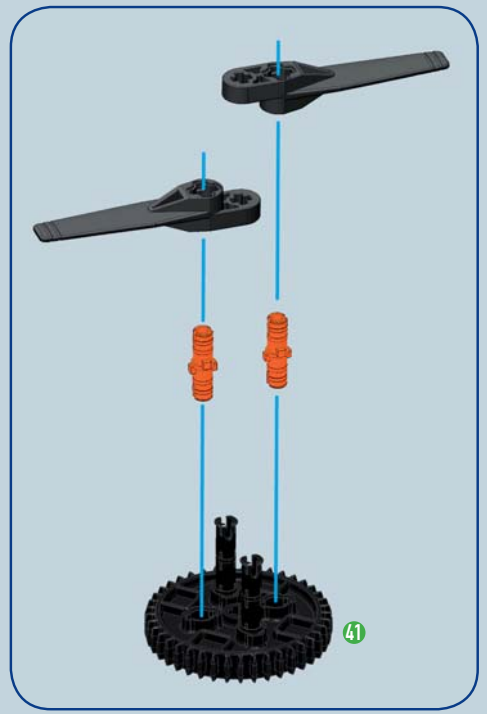
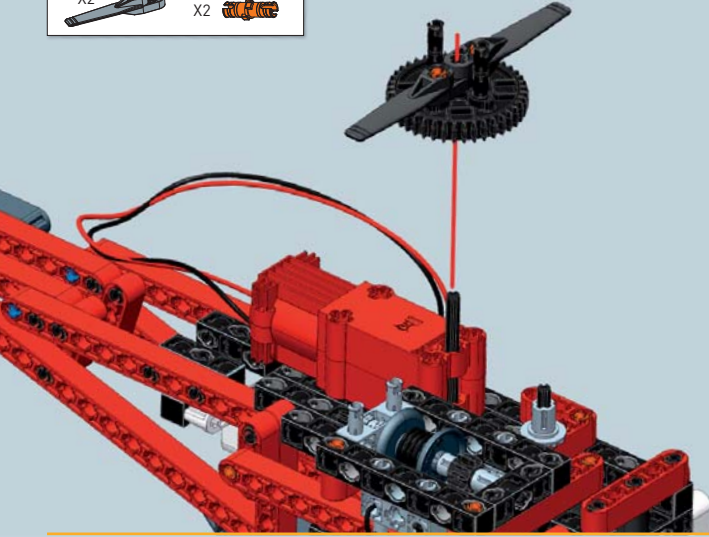
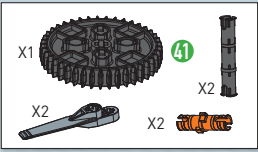

56

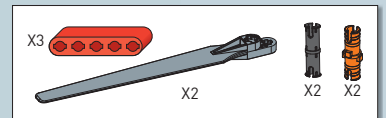
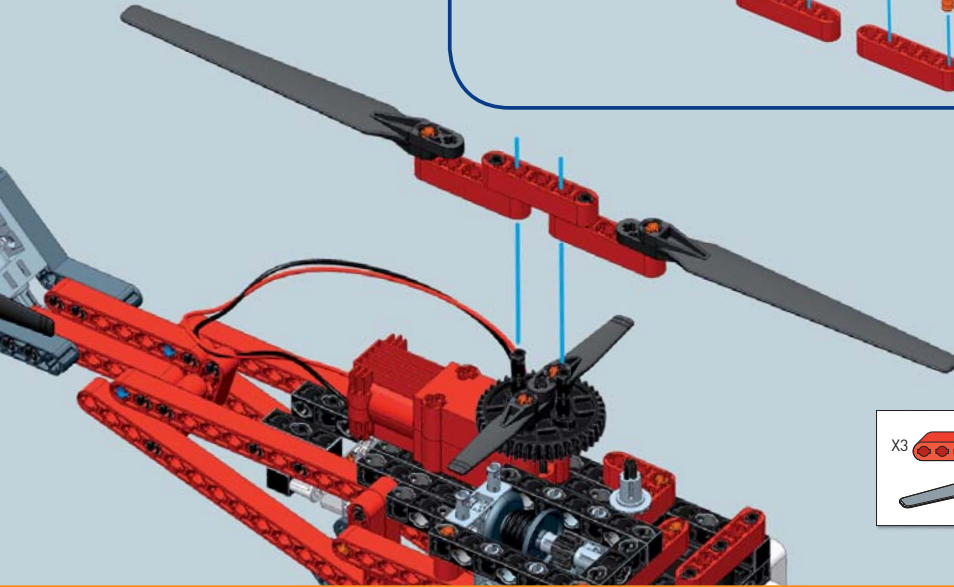
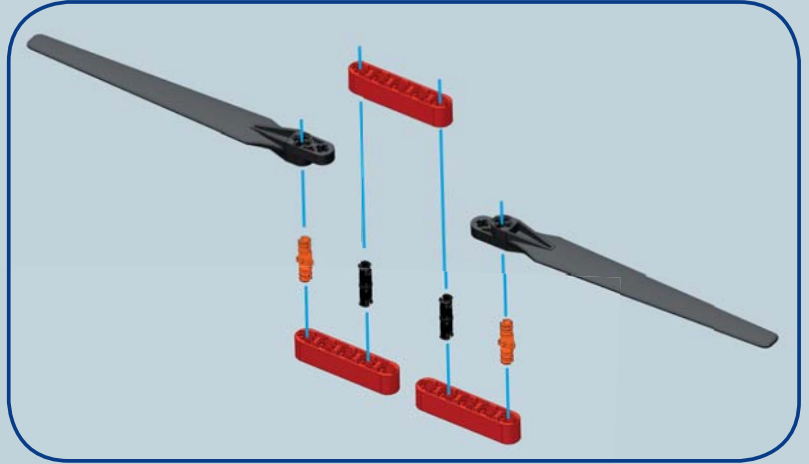

**PORTANZA:** è la forza che contrasta la gravità, permettendo ad un aereo o ad un elicottero di alzarsi in volo. Grazie al **profilo alare**, il flusso d'aria scorre con velocità diverse sulle due superfici dell'ala: più lentamente sul **ventre** e a velocità maggiore sul **dorso**. Il flusso più lento esercita una **pressione maggiore**, producendo una **spinta verso l'alto**.



## VOLARE CON UN ELICOTTERO

In un elicottero la forza che permette il sollevamento, chiamata **portanza**, è generata da un'ala rotante denominata **rotore**. Il rotore è formato da un asse rotante a cui vengono fissate 2 o più pale.

### Rotore principale e rotore di coda

Il **rotore principale** permette all'elicottero di sollevarsi in volo. C'è bisogno però di un secondo rotore, detto **rotore di coda**, per mantenere allineata la fusoliera. Nell'elicottero infatti entra in gioco la **terza legge della dinamica** (ad ogni azione corrisponde una reazione uguale e contraria): l'azione rotante delle **pale** produce una **reazione contraria** sull'intera fusoliera, portandola a ruotare in senso opposto. Il **rotore di coda** produce una spinta che si **oppone e compensa** quella che agisce sulla fusoliera. Senza questo secondo rotore, l'elicottero inizierebbe a ruotare su se stesso in maniera incontrollata.

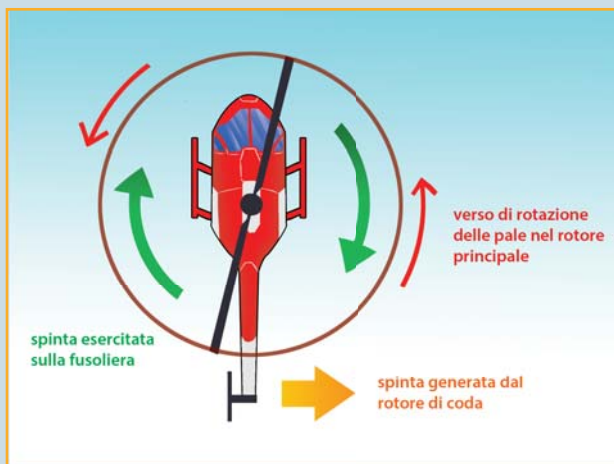

### IL PIATTO OSCILLANTE

L'organo essenziale per il pilotaggio di un elicottero è il **piatto oscillante**. Monta attorno all'asse rotante, è connesso alle pale e libero di muoversi verso l'alto o verso il basso per generare portanza.



Il pilota può agire anche sull'**inclinazione del piatto oscillante**, ottenendo così l'inclinazione del **disco del rotore**. Ciò genera due zone a differente portanza, indirizzando il movimento dell'elicottero verso la zona a minor portanza.



## PILOTARE UN ELICOTTERO

Pilotare un elicottero richiede grande coordinazione perché il pilota deve agire contemporaneamente su 3 comandi principali: la **leva del passo collettivo**, per il volo verticale; la **leva del passo ciclico**, per il movimento nello spazio; la **pedaliera** per cambiare direzione.

### Leva del passo ciclico



Il pilota manovra la leva e l'elicottero si sposta a destra o sinistra, avanti o indietro.

### Leva del passo collettivo



Il pilota manovra la leva e l'elicottero sale o scende di quota.

### Pedaliera



Il pilota manovra i pedali e l'elicottero cambia direzione.

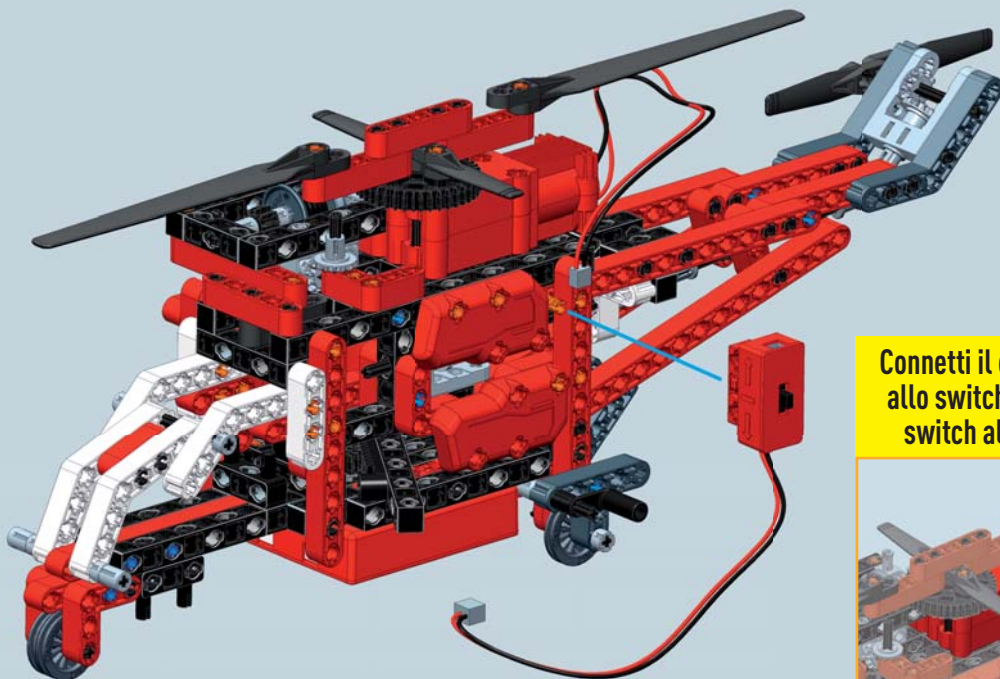
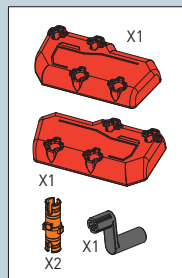
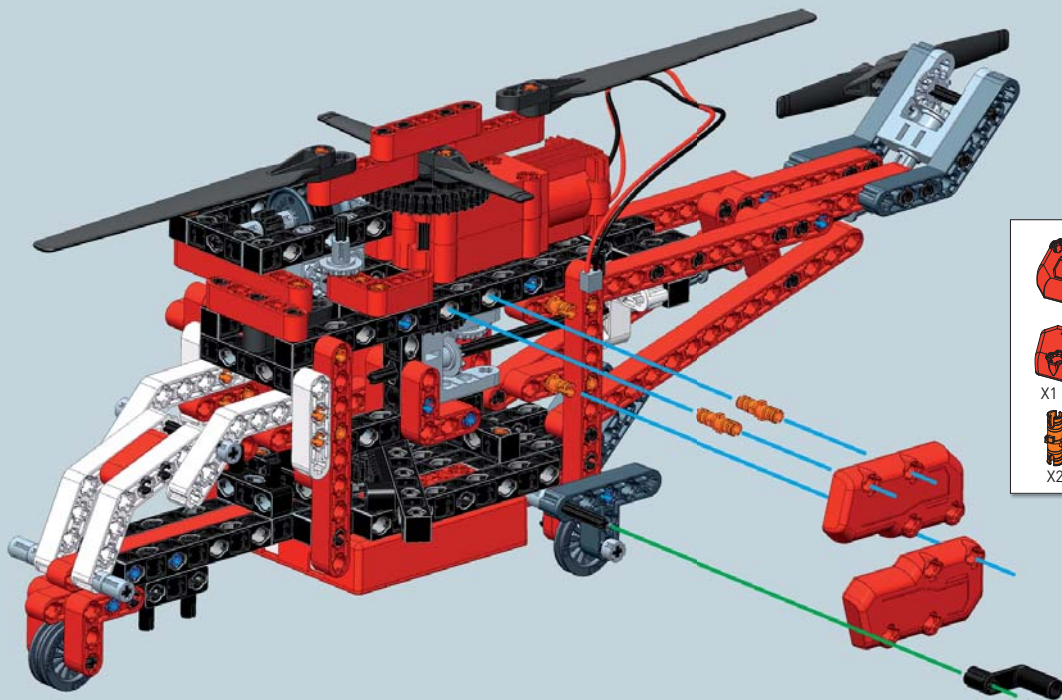

Connetti il cavo del motore allo switch e il cavo dello switch al vano batterie

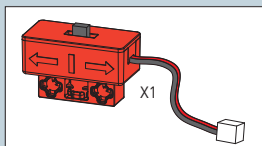
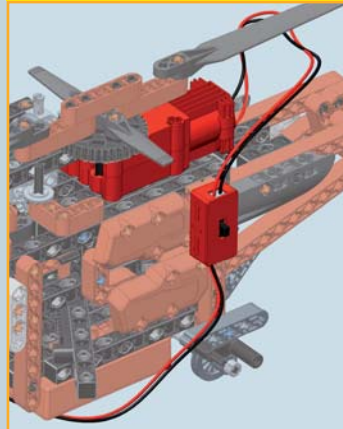

59

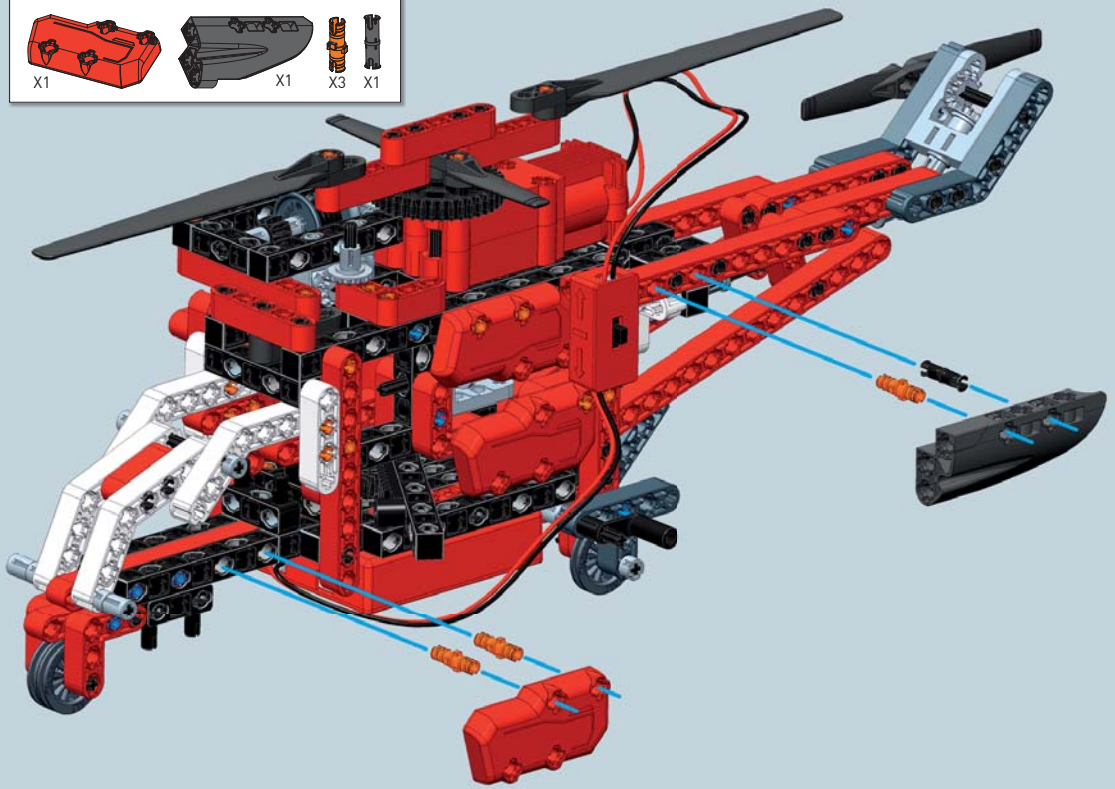
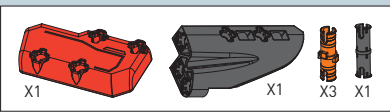

60

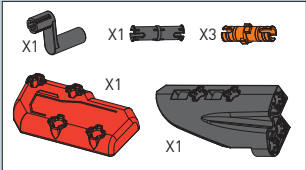
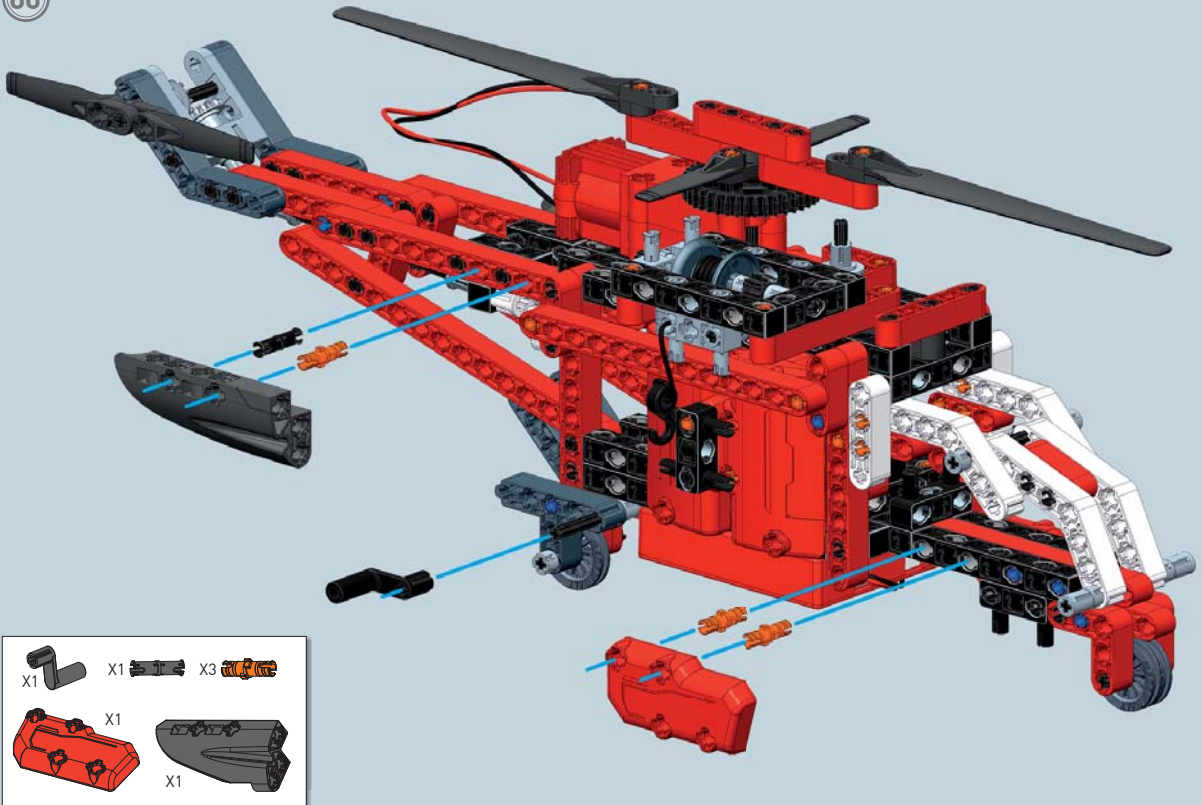

61

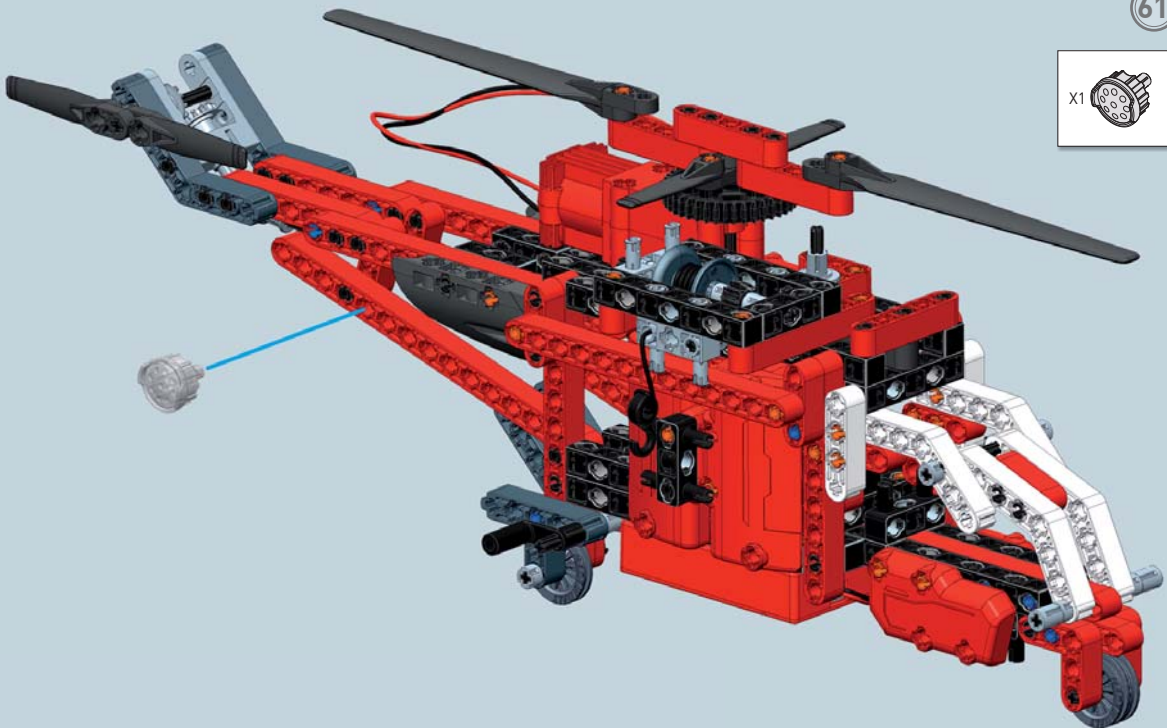

62

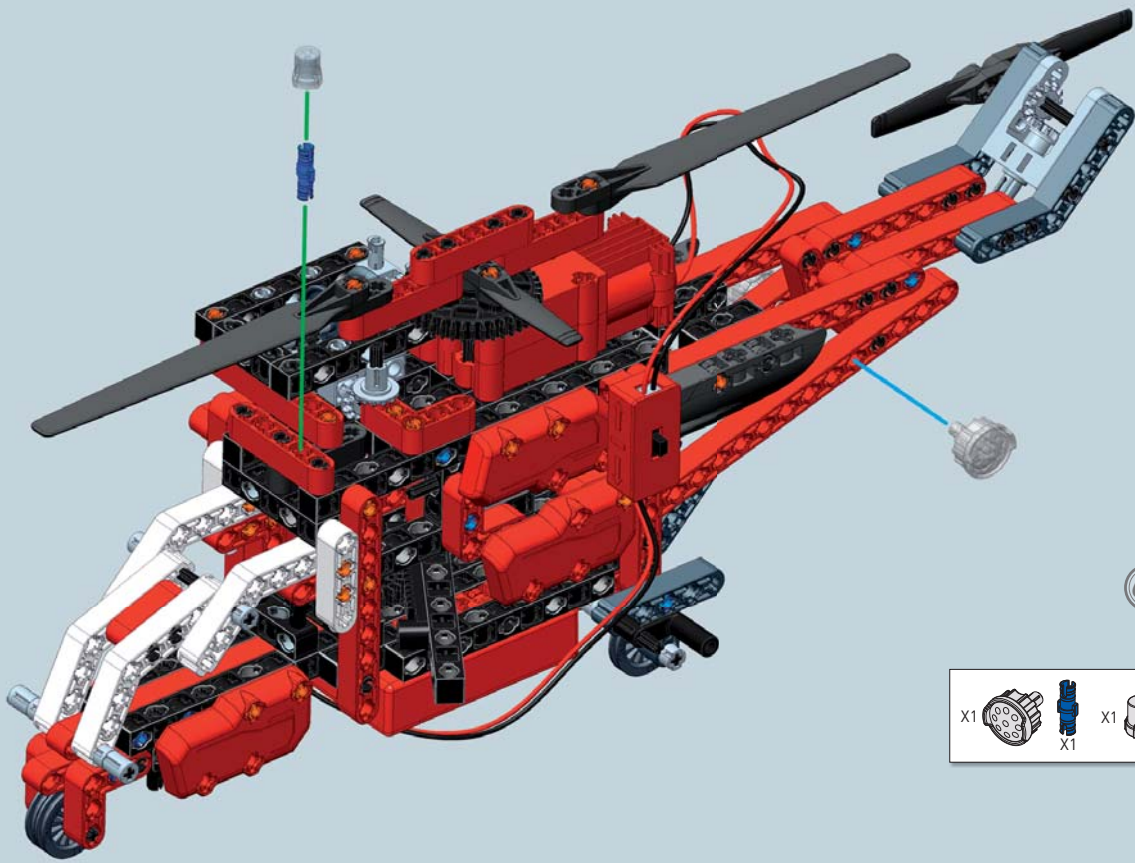
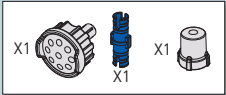

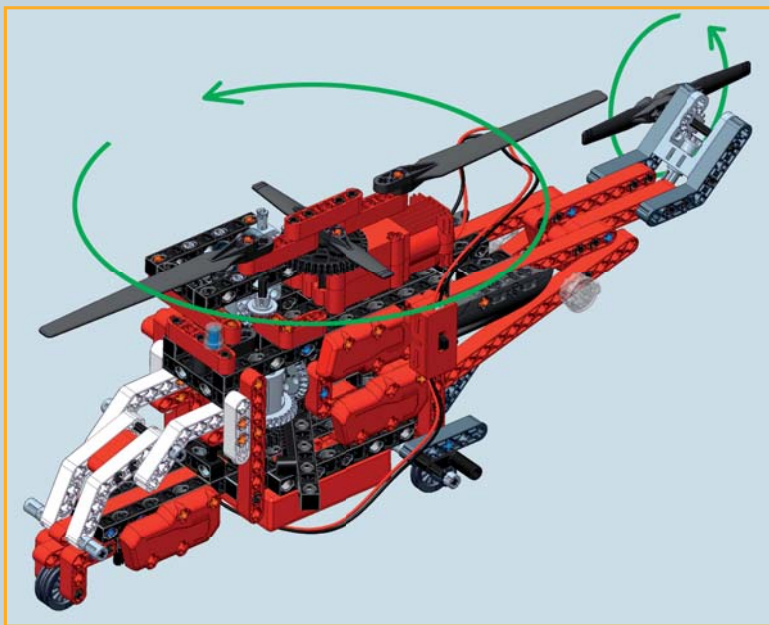

Attiva la rotazione contemporanea del rotore principale e del rotore di coda, tramite il tasto dello switch

### ATTIVAZIONE DEL VERRICELLO TRAMITE DIFFERENZIALE

Per attivare il verricello devi spingere la leva al lato della fusoliera: la leva agisce bloccando l'asse del differenziale connesso alla ruota a 18 denti, così da trasferire la potenza del motore all'altro asse, connesso al verricello tramite i due satelliti. Se la leva non viene premuta, la vite senza fine blocca l'asse connesso al verricello e la rotazione viene trasferita solo all'asse connesso alla ruota a 18 denti.

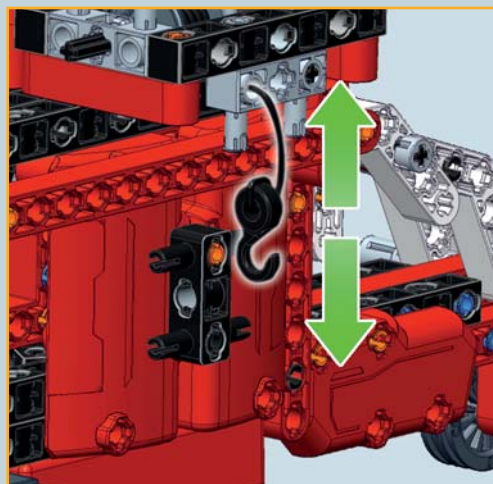
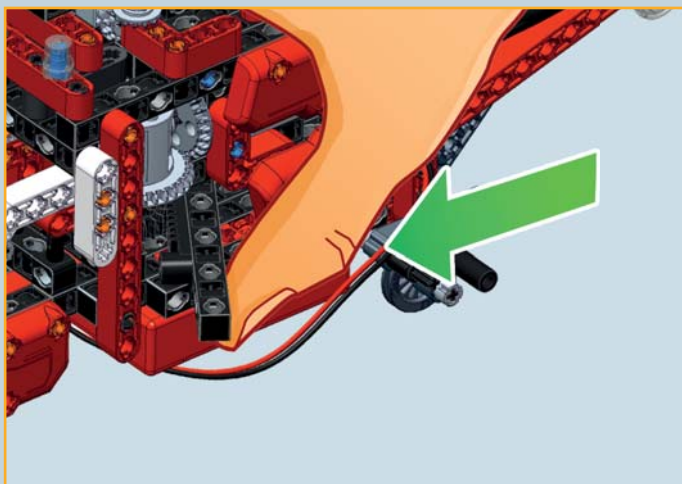

**LEVA NON PREMUTA – rotori attivi**

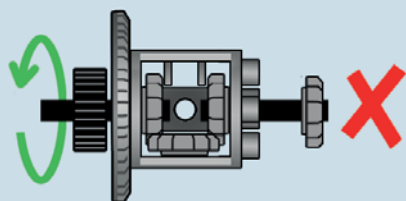

**LEVA PREMUTA – rotori e verricello attivi**

