

ciencia
juego

TECHNOLOGIC

Laboratorio de MECÁNICA

CAMIONES DE TRANSPORTE

Construcciones de 1 a 10

- 1 - Cómo funciona el diferencial
- 2 - El camión antiguo
- 3 - El camión minero
- 4 - El camión europeo
- 5 - Camión con pinza
- 6 - Camión con volquete
- 7 - Grúa
- 8 - Grúa de brazo
- 9 - Quitanieves
- 10 - El camión americano



V42479

SUCURSAL EN ESPAÑA:
Clementoni Ibérica S.L.
Avenida Brasil 17, 5ºD
28020 - Madrid
Tel.: +34 91-5568061
e-mail: clemen@clementoni.es

FABRICANTE:
Clementoni S.p.A.
Zona Industriale Fontenoce s.n.c.
62019 Recanati (MC) - Italy
Tel.: +39 07175811
www.clementoni.com

Leer el manual y conservarlo para futuras consultas.



LISTA DE COMPONENTES

	Barra doble de 15 orificios	pz. 2		Anillo corto	pz. 12		Rueda de 10 dientes	pz. 2
	Barra doble de 11 orificios	pz. 2		Anillo largo	pz. 12		Rueda de 18 dientes	pz. 5
	Barra doble de 9 orificios	pz. 2		Tornillo sinfin	pz. 1		Rueda de 26 dientes	pz. 1
	Barra doble de 7 orificios	pz. 6		Jaula porta-satélites	pz. 1		Rueda de 41 dientes	pz. 1
	Barra doble de 5 orificios	pz. 6		Rueda de 32 dientes	pz. 1		Módulo de transmisión	pz. 2
	Barra doble de 3 orificios	pz. 6		Rueda de 24 dientes	pz. 1		Neumático	pz. 4
	Barra simple de 15 orificios	pz. 2		Rueda de 12 dientes	pz. 9		Llanta de 8 orificios	pz. 2
	Barra simple de 13 orificios	pz. 2		Clavo corto doble	pz. 16		Llanta de 4 orificios	pz. 2
	Barra simple de 9 orificios	pz. 2		Clavo corto simple	pz. 8		Barra simple de 7 orificios	pz. 4
	Barra simple de 7 orificios	pz. 2		Clavo corto	pz. 32		Barra simple de 5 orificios	pz. 4
	Barra simple de 5 orificios	pz. 2		Clavo largo doble	pz. 8		Barra simple de 3 orificios	pz. 4
	Barra simple de 3 orificios	pz. 2		Clavo largo	pz. 16		Módulo en ángulo alto	pz. 4
	Módulo en ángulo alto	pz. 2		Barra con clavos	pz. 4		Módulo en ángulo bajo	pz. 4
	Módulo en ángulo bajo	pz. 2		Barra con pernos	pz. 6		Cabina de la grúa móvil	pz. 1
	Barra de 4 orificios	pz. 2		Gancho	pz. 1		Panel de cabina DCH.	pz. 1
	Barra en T	pz. 2		Manivela	pz. 2		Panel de cabina IZQ.	pz. 1
	Barra en ángulo	pz. 4		Varilla dentada	pz. 1			
	Varilla 7 larga cm 9,9	pz. 1		Taco	pz. 2			
	Varilla 6 larga cm 11,7	pz. 1						
	Varilla 5 larga cm 8,1	pz. 1						
	Varilla 4 larga cm 7,2	pz. 1						
	Varilla 3 larga cm 5,4	pz. 5						
	Varilla 2 larga cm 3,6	pz. 2						
	Varilla 1 larga cm 2,7	pz. 1						

El motor de combustión interna

El motor de combustión interna es una máquina para transformar la energía química en potencia mecánica. Para generar potencia mecánica necesitamos:

Combustible: Gas, gasolina o gasóleo



Comburente: Oxígeno

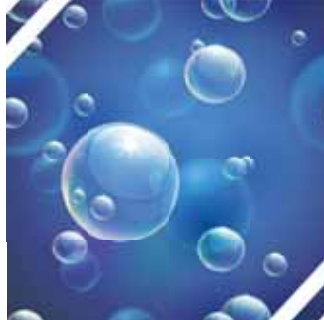

Cámara de combustión: Contenedor donde se produce la reacción de combustión entre combustible y comburente.

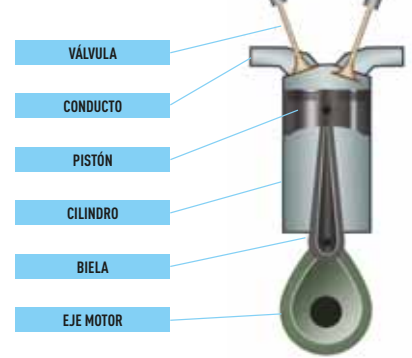

¿Cómo funciona? Las fases que permiten la combustión son en total 4:



FASE 1

Aspiración:
el pistón baja.
El aire o la mezcla aire/
combustible es aspirada en el
cilindro.



FASE 2

Compresión:
el pistón sube.
La mezcla aire-combustible se
comprime.
Comienza la combustión.



FASE 3

Encendido y expansión:
el pistón baja.
Se produce la combustión,
que conduce a la expansión
instantánea de los gases. El
pistón es empujado hacia abajo.



FASE 4

Descarga:
el pistón sube.
Los residuos de la combustión son
expulsados por el cilindro.

A cada ciclo que se acaba de describir corresponden dos rotaciones del eje motor, que en consecuencia transmite el movimiento a los demás órganos mecánicos del vehículo.

Motor de gasolina vs. motor diésel. Un motor de gasolina difiere de un motor diésel por la fase de encendido:



MOTOR DE GASOLINA

Es un motor de encendido controlado. El encendido se produce gracias a una descarga eléctrica que enciende la mezcla aire/combustible.

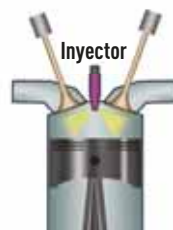

MOTOR DIÉSEL

Es un motor de encendido espontáneo. El combustible es inyectado en el cilindro solo después de la fase de compresión. El aire comprimido alcanza temperaturas tan elevadas que enciende el combustible.

Los camiones de transporte pueden equiparse con herramientas de trabajo accionadas por actuadores específicos que utilizan la presión del aceite hidráulico para efectuar un desplazamiento.

El pistón hidráulico es un actuador constituido por dos partes mecánicas:

- El cilindro, constituido por un cuerpo cilíndrico vacío.
- El pistón o vástago, constituido por una varilla maciza.



CILINDRO

CAVIDAD PARA EL ACEITE
HIDRÁULICO

PISTÓN O VÁSTAGO

¿Cómo funciona? El pistón hidráulico está constituido por un cilindro de doble efecto, donde el aceite hidráulico puede introducirse por dos extremos, bajo el control del operador.

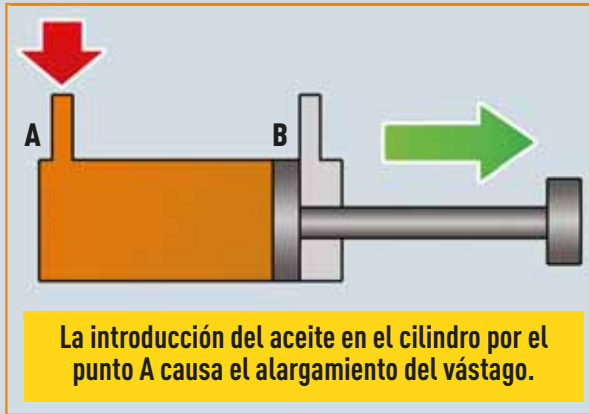

La introducción del aceite en el cilindro por el punto A causa el alargamiento del vástago.

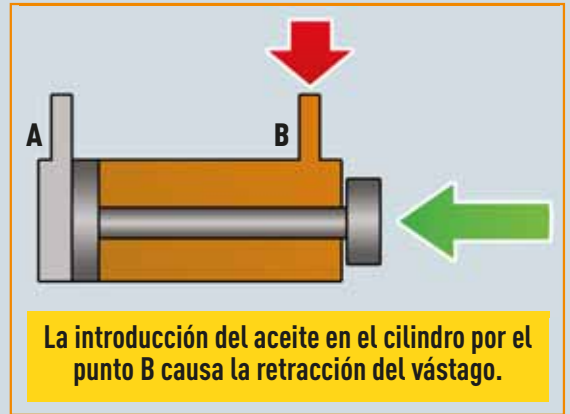

La introducción del aceite en el cilindro por el punto B causa la retracción del vástago.

Circuito hidráulico

El aceite hidráulico pasa por un circuito cerrado.

Desde un depósito de almacenaje, el aceite es aspirado por una primera bomba y enviado al distribuidor.

El distribuidor abre y cierra las dos vías de acceso al pistón, provocando, bajo el control del operador, el alargamiento o la retracción del vástago. Como se trata de un circuito cerrado, el aceite empujado por un lado del cilindro se descarga nuevamente en el depósito gracias al distribuidor.

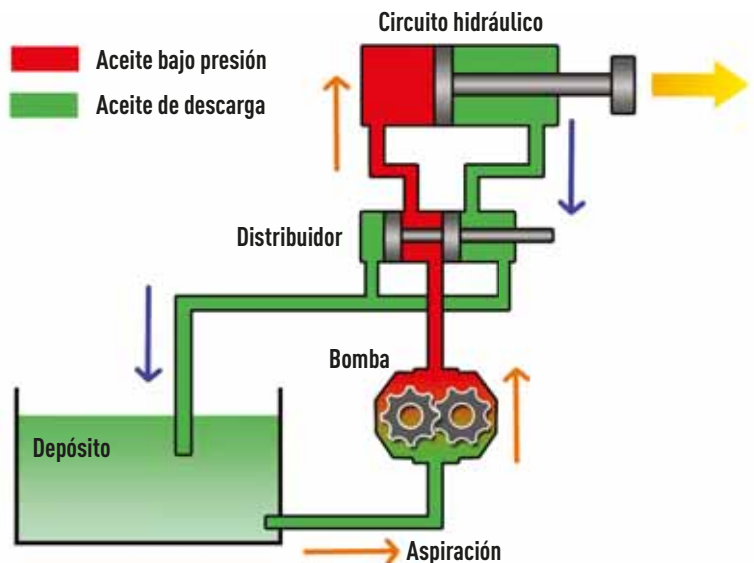

1 Cómo funciona el diferencial



Profundización técnico-científica

El diferencial es un órgano mecánico que transmite la potencia generada por el motor al par de ruedas motrices.



- 1 **Piñón:** transmite potencia del motor a la corona y por último a las ruedas motrices.
- 2 **Corona:** vinculada a la jaula porta-satélites, está acoplada establemente al piñón.
- 3 **Jaula porta-satélites:** es la caja que contiene los engranajes.
- 4 **Satélites:** engranajes vinculados a la jaula.
- 5 **Planetarios:** engranajes vinculados a los semiejes.
- 6 **Semieje:** eje que une las ruedas motrices a los planetarios.

Está diseñado para permitir que las dos ruedas giren a distinta velocidad en curva: en los tramos no rectilíneos, la rueda externa a la curva recorre más distancia que la interna, por lo que la externa debe girar más rápidamente.

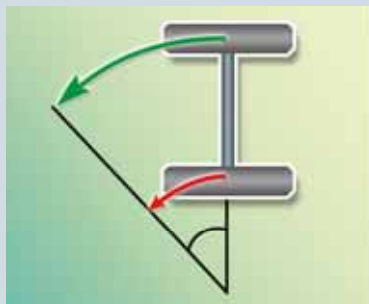

El piñón transmite la potencia del motor al diferencial y en consecuencia, a los semiejes.

En curva la rueda interna recorre menos distancia que la externa.

Gracias al diferencial, en curva, las ruedas de un vehículo pueden girar a distintas velocidades.

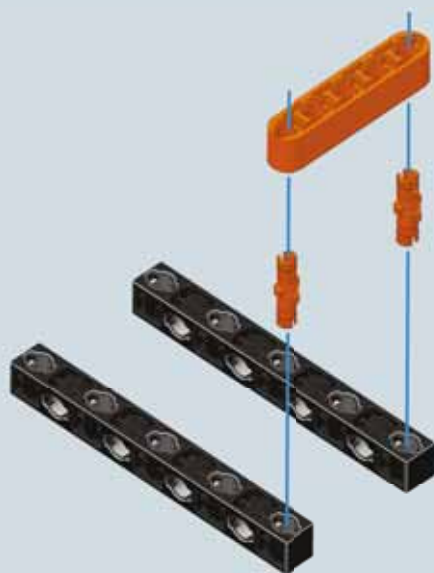

1

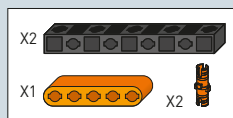

2

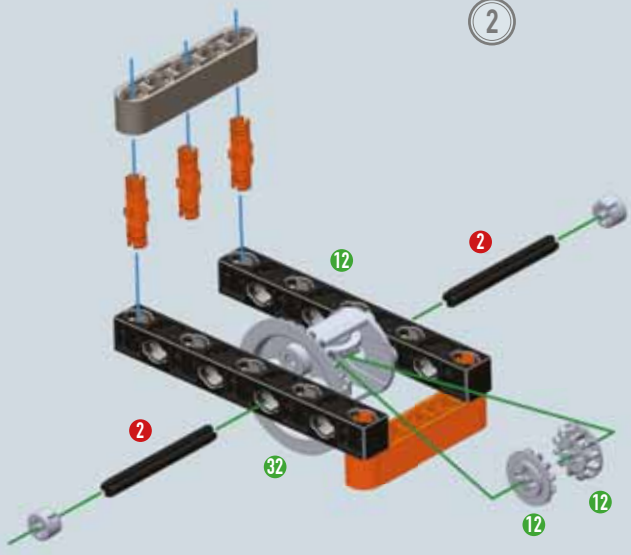

- X1
- X2
- X1
- X3
- X2
- X3

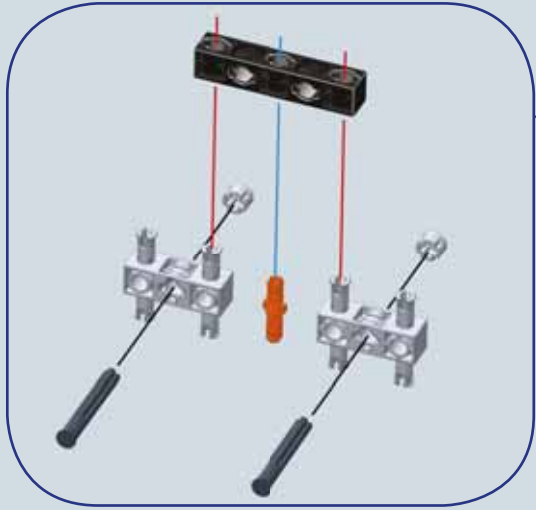
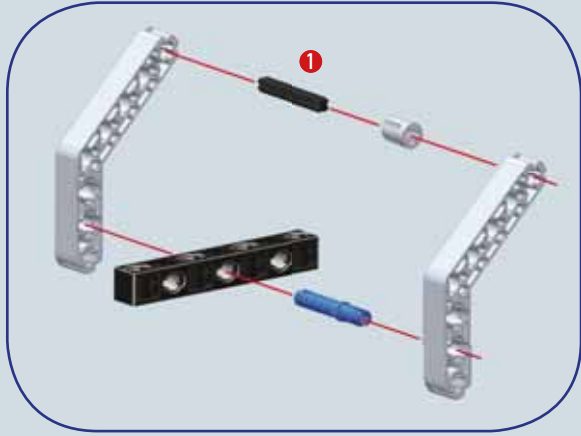
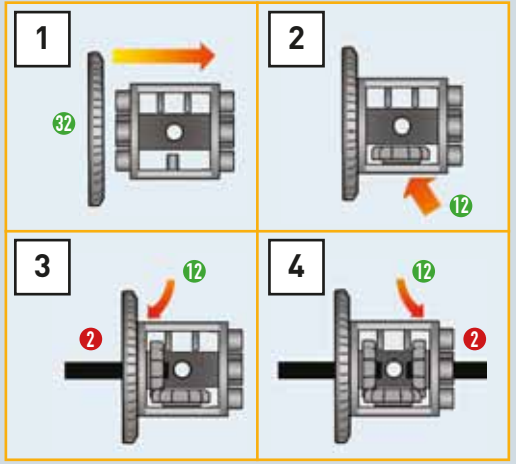

- X1
- X1
- X1
- X1
- X2
- X1
- X1
- X1
- X1
- X1
- X1
- X2
- X2
- X2

3

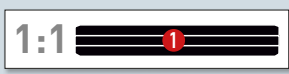
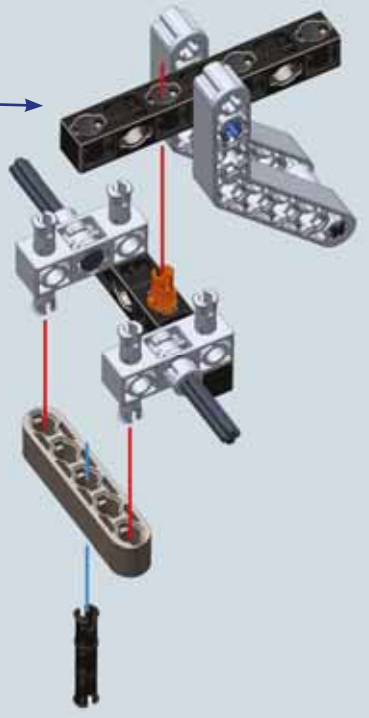

4

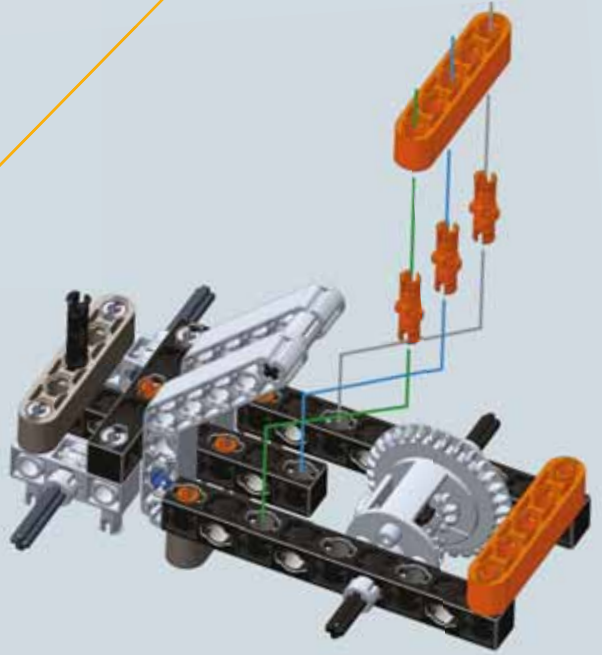
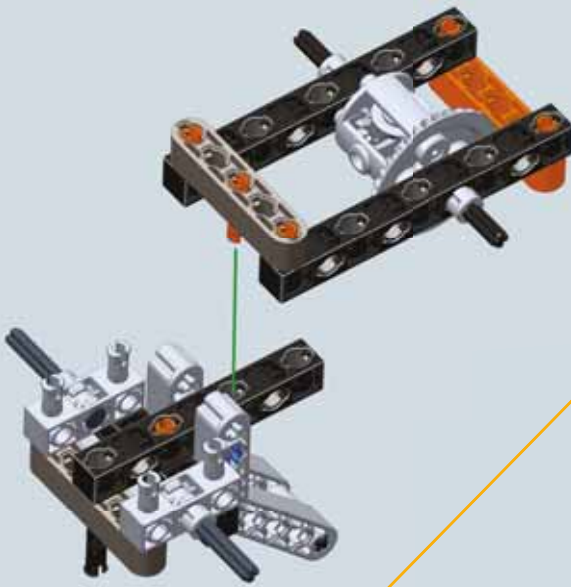

5

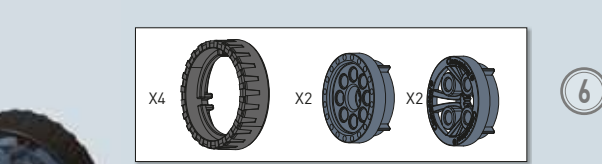
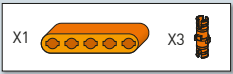

6

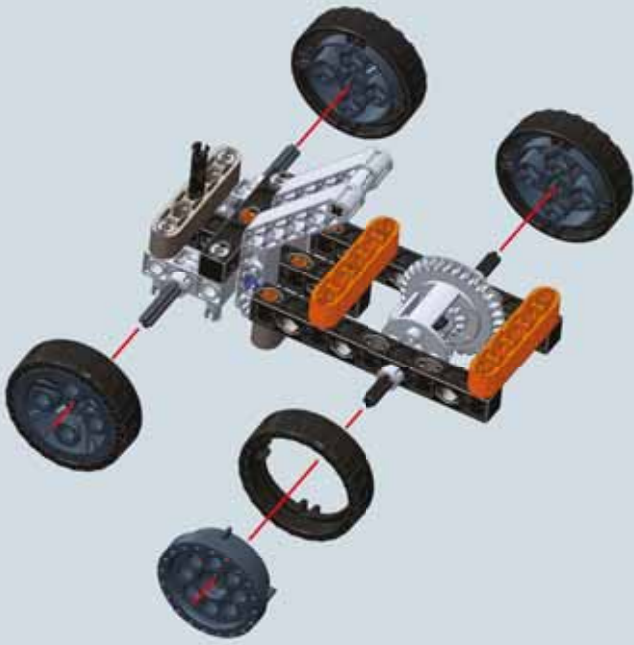

Modelo final

2 El camión antiguo



Notas técnicas y curiosidades

El primer camión de la historia se realizó en 1896. El proyecto inicial era bastante sencillo y se inspiraba en los carros de aquella época: la parte delantera, en la que se enganchaban los animales de tiro, se había eliminado y el carro se había equipado con un motor capaz de impulsar el vehículo a una velocidad de 16 km/h. Las ruedas seguían siendo de madera con la llanta externa de metal. También el sistema de frenos era el mismo utilizado en las carrozas.

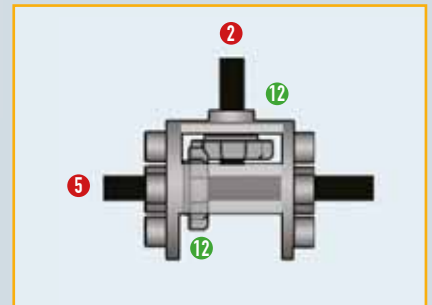
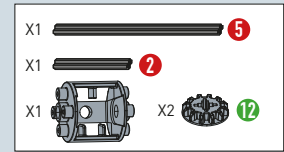
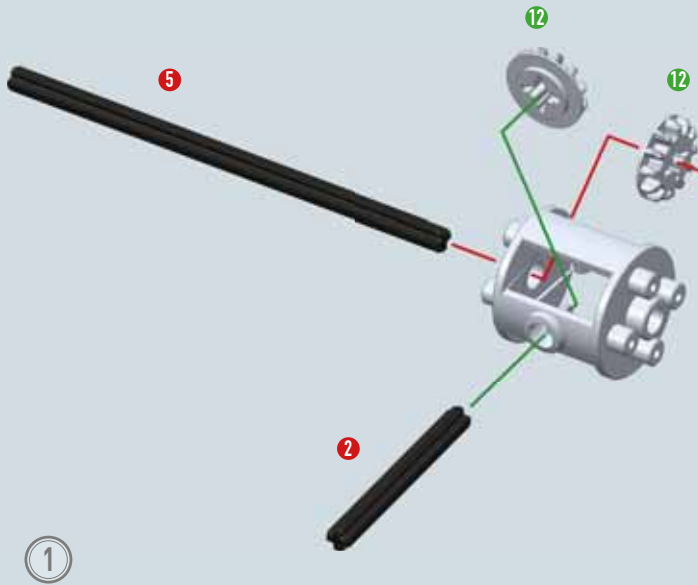

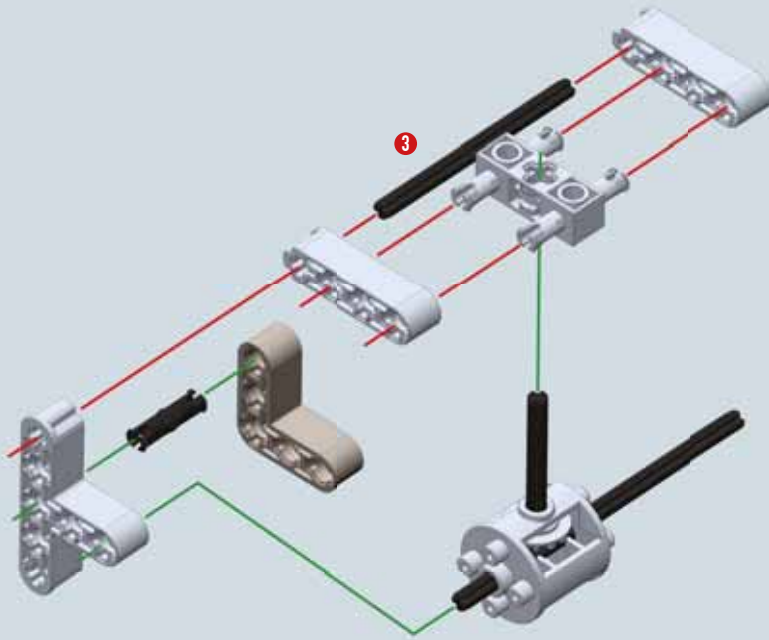

2

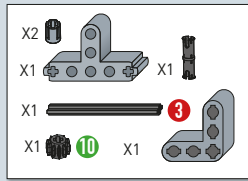
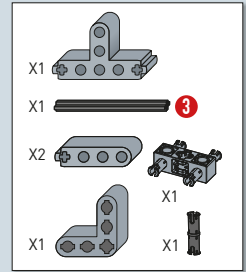

3

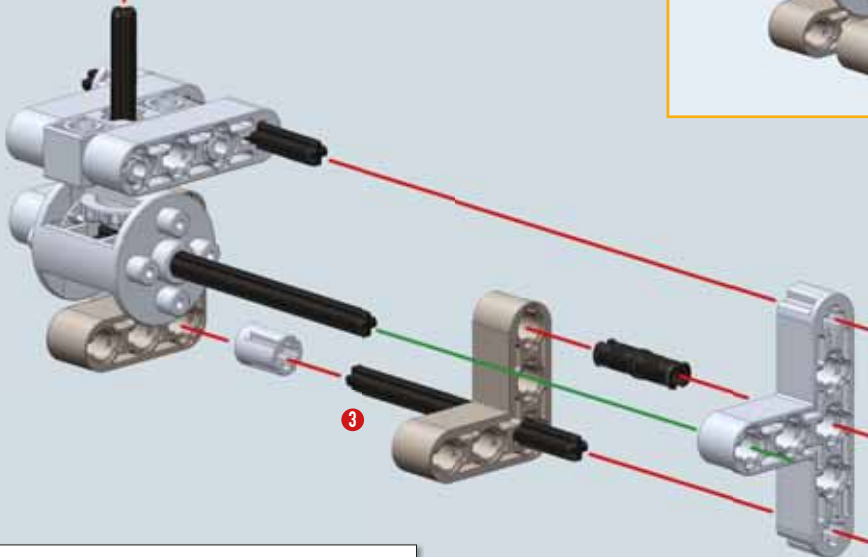
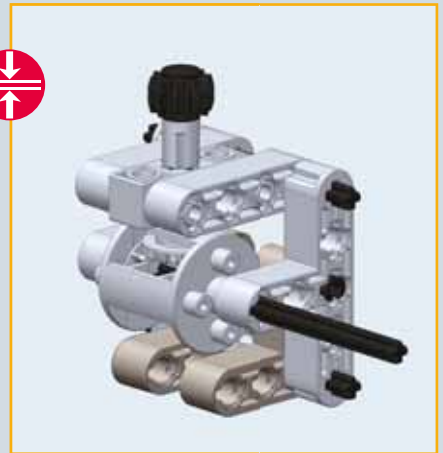

4

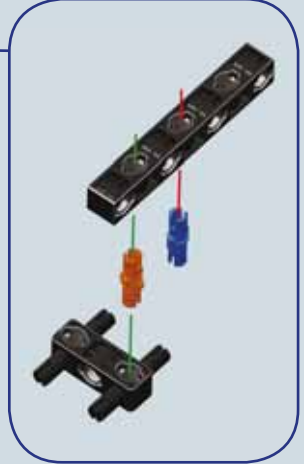
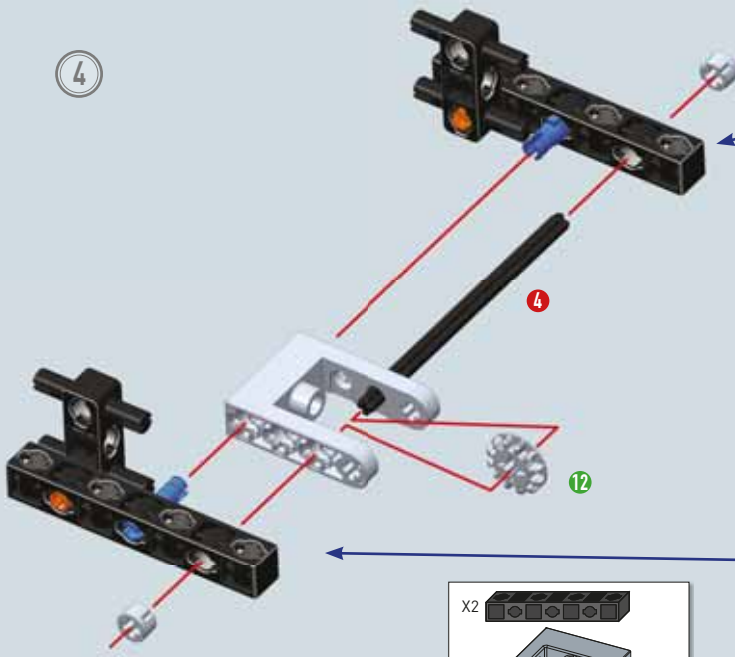

- X2
- X1
- X2
- X2
- X2
- X1



5

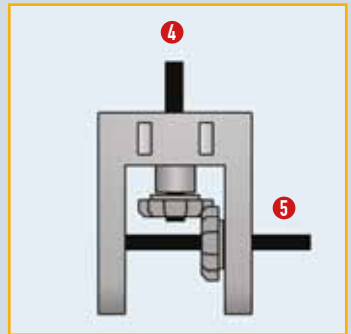
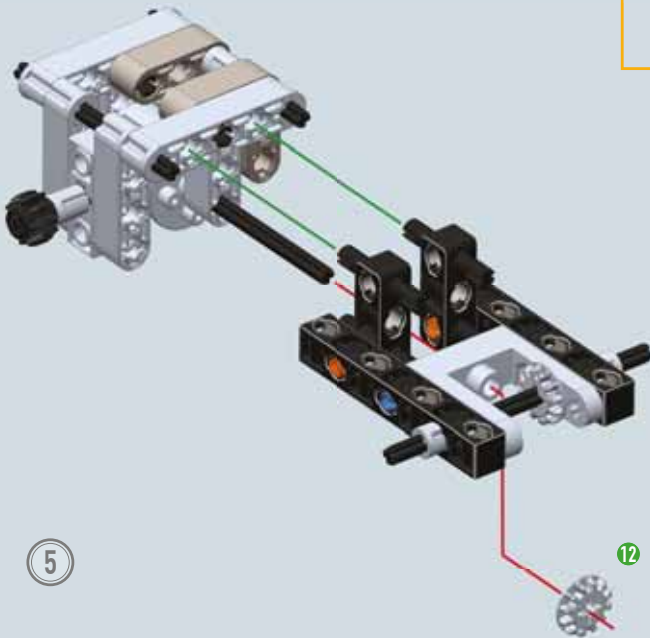

- X1

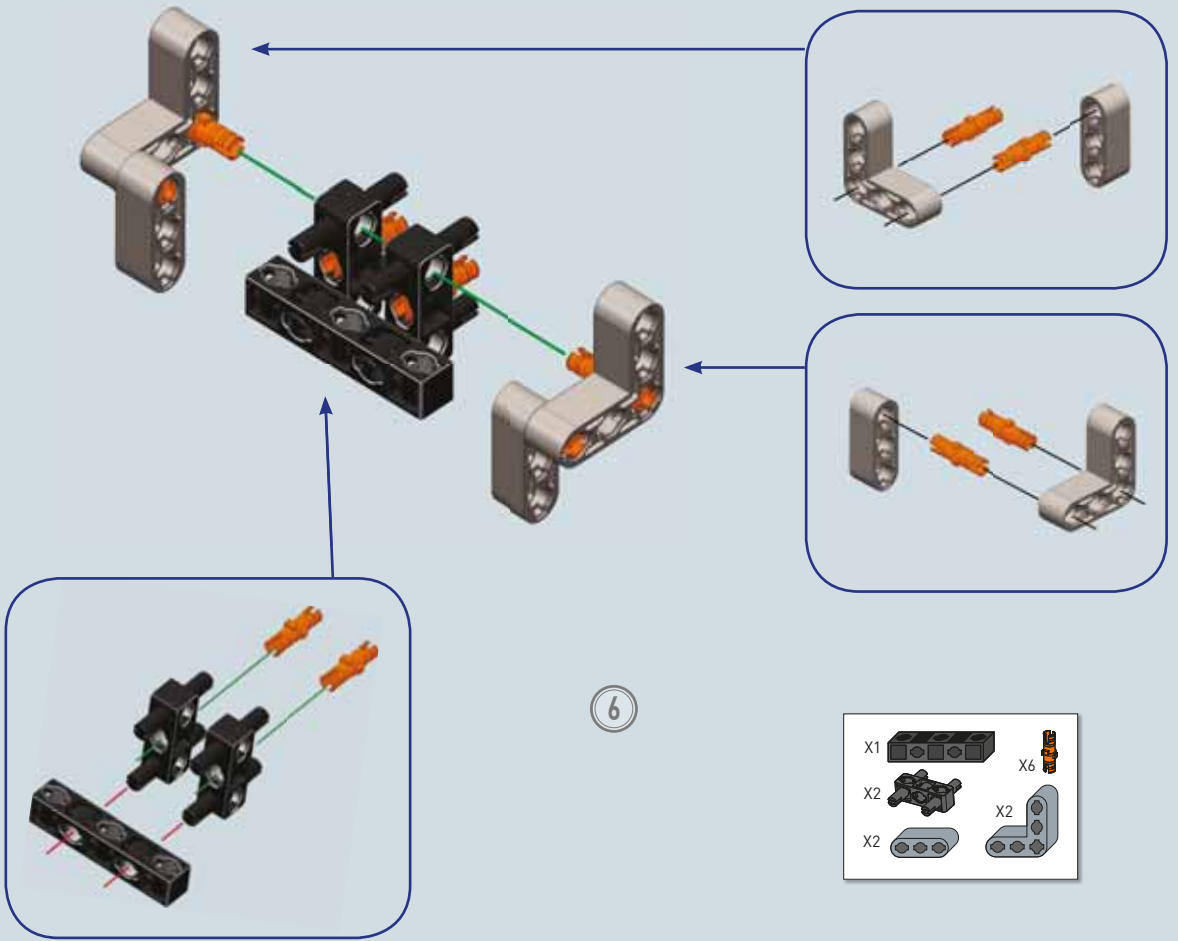

7

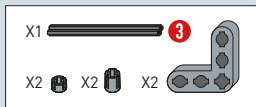
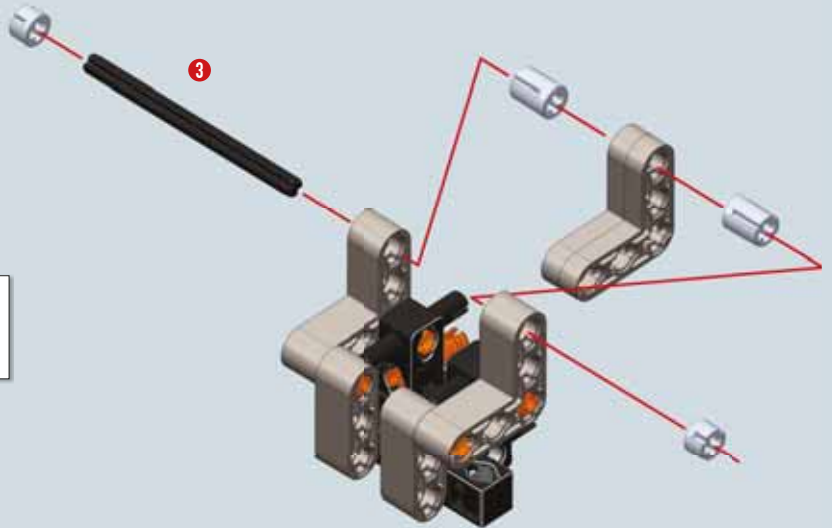

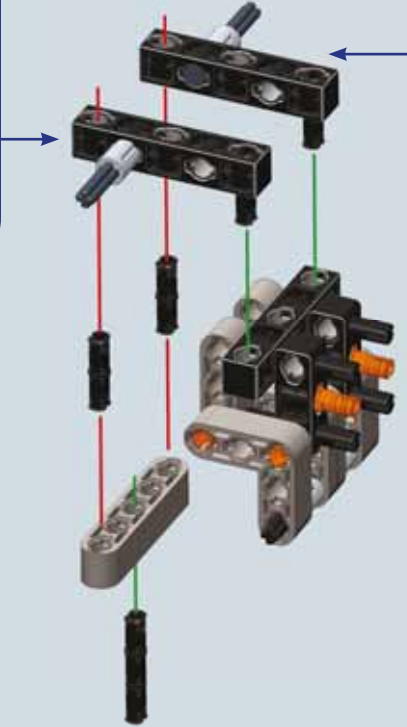
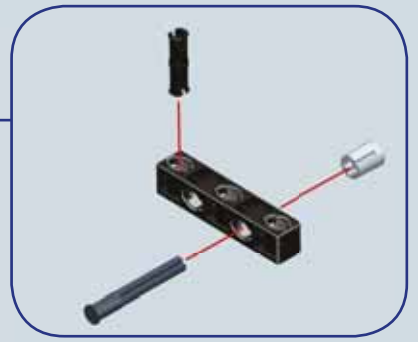

8

X1		X4	
X2		X2	
X2		X1	

9

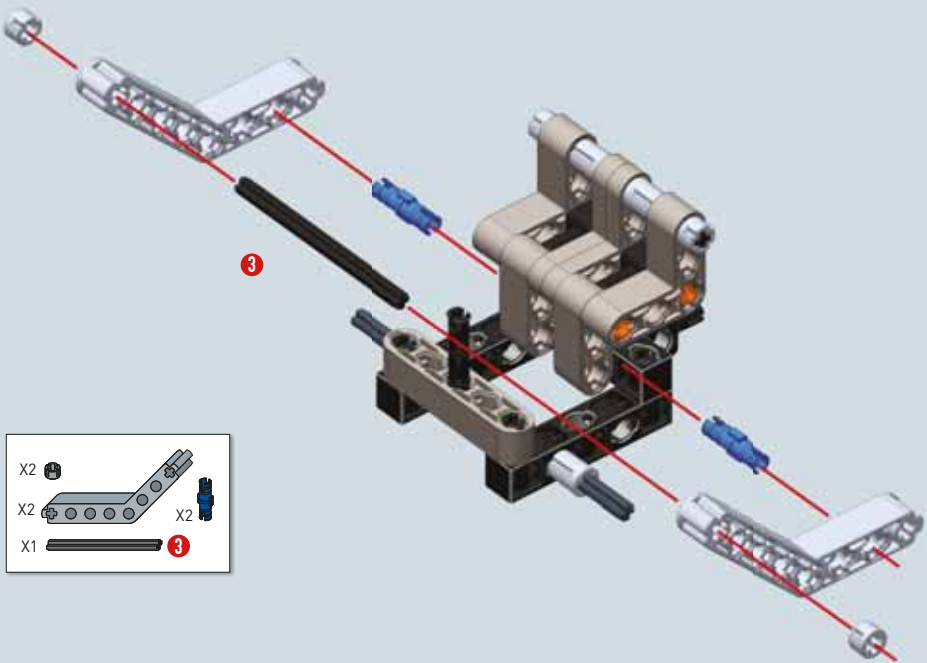

X2			
X2		X2	
X1			



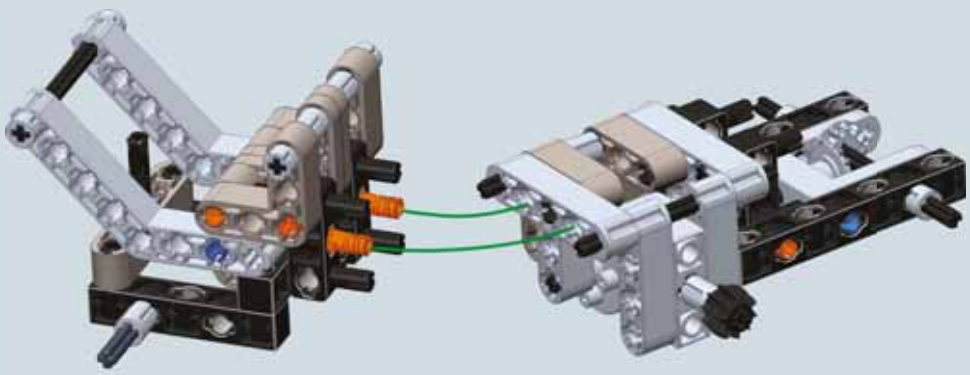

10

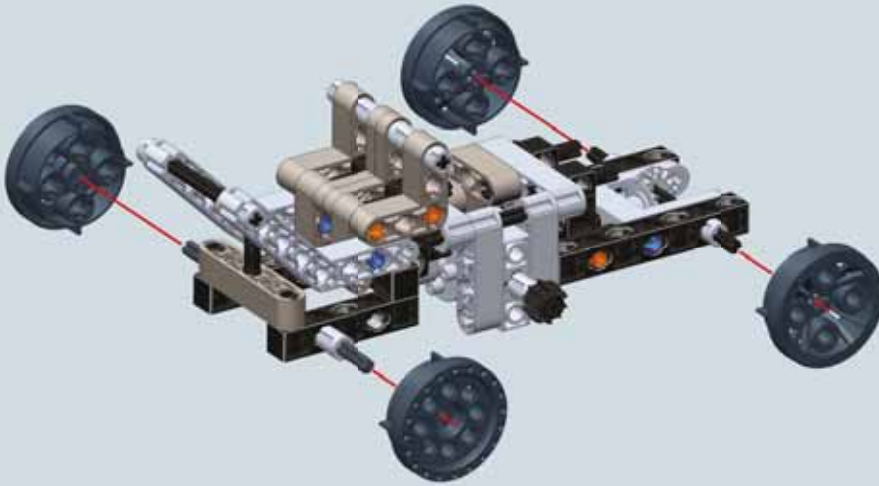

11

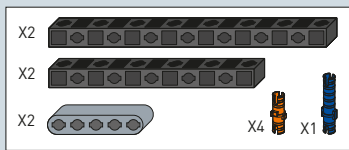
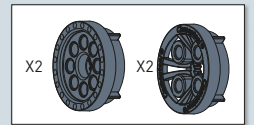

12

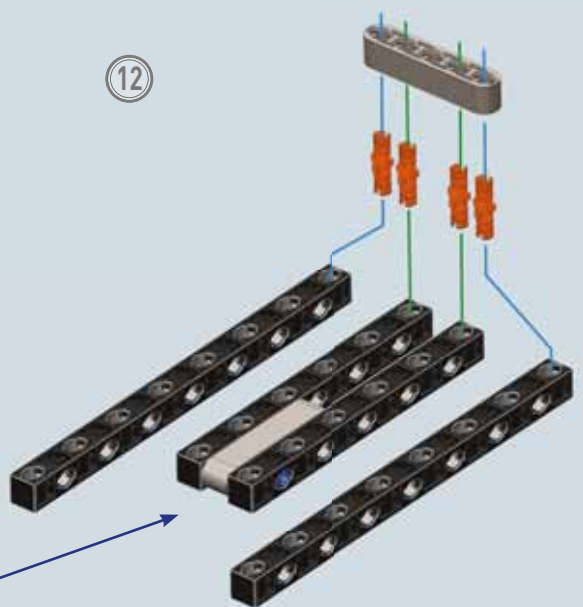
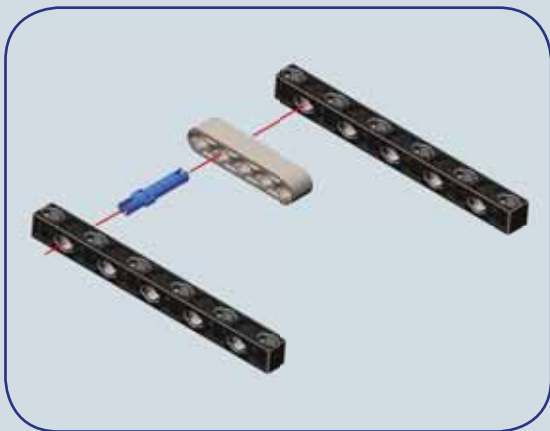

14

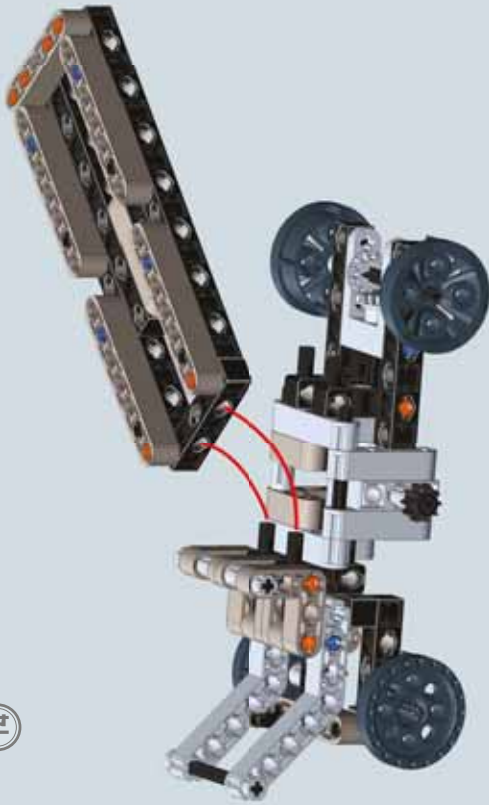

Modelo final

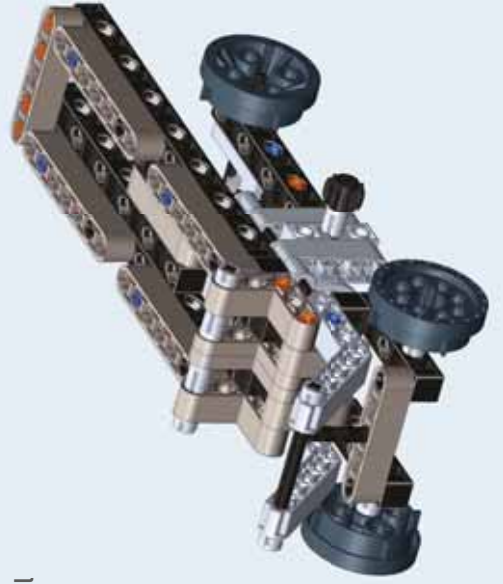

13

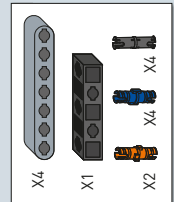
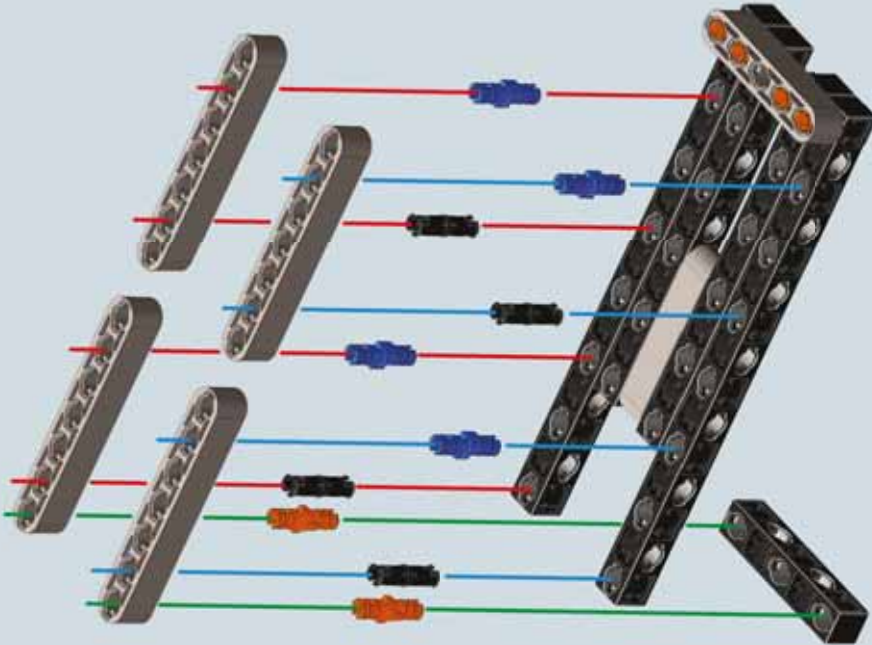



Notas técnicas y curiosidades

Los camiones que se emplean en la industria minera son auténticos gigantes sobre ruedas. Los modelos más grandes pueden alcanzar los 7 metros de altura (como un edificio de dos plantas) y llevan instalado un motor diésel del tamaño de una furgoneta. El volquete tiene unos 10 metros de largo y puede transportar una cantidad enorme de material terroso. Completamente cargado, este camión puede pesar hasta 600 toneladas. Por lo general tiene 6 ruedas, que son grandes (de unos 4 metros de diámetro).

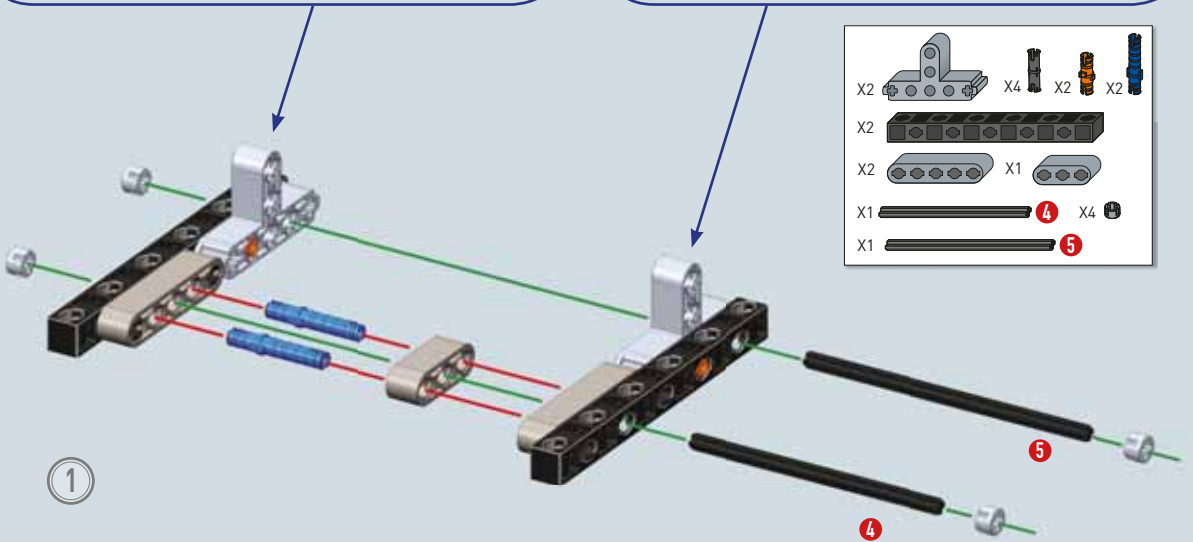
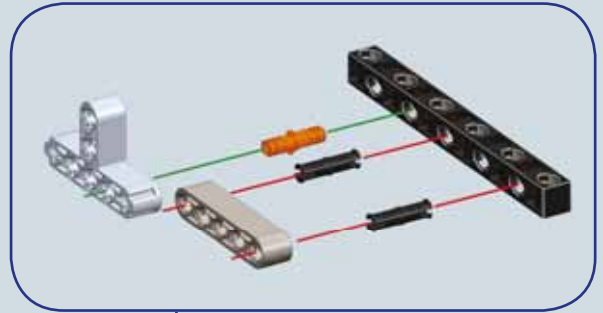
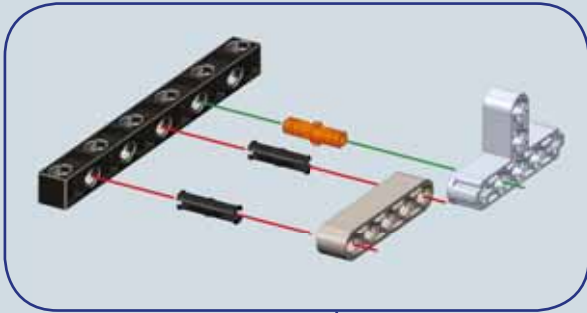

2

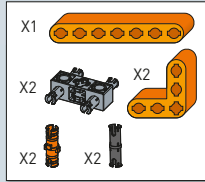
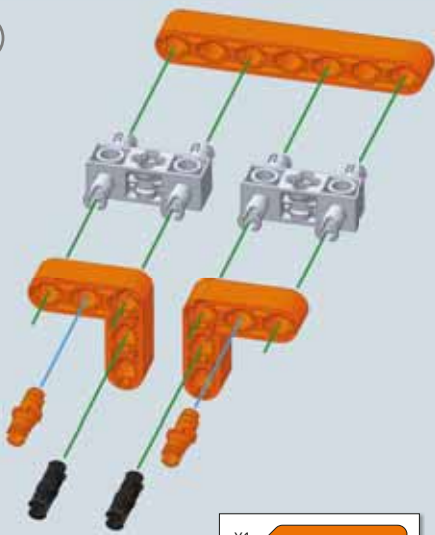

3

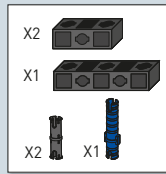

4

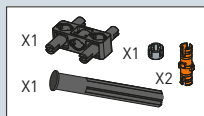

5

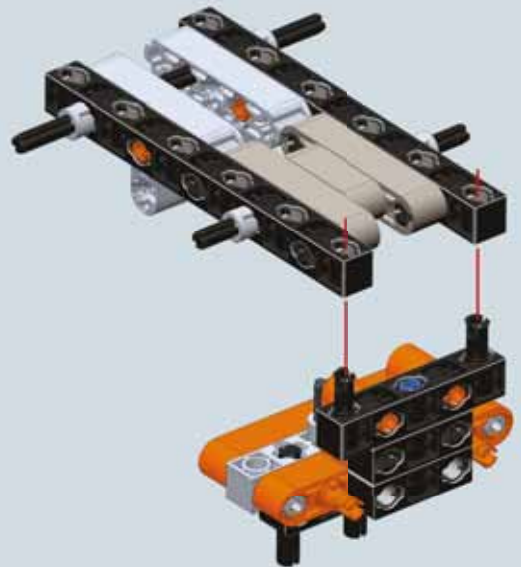

6

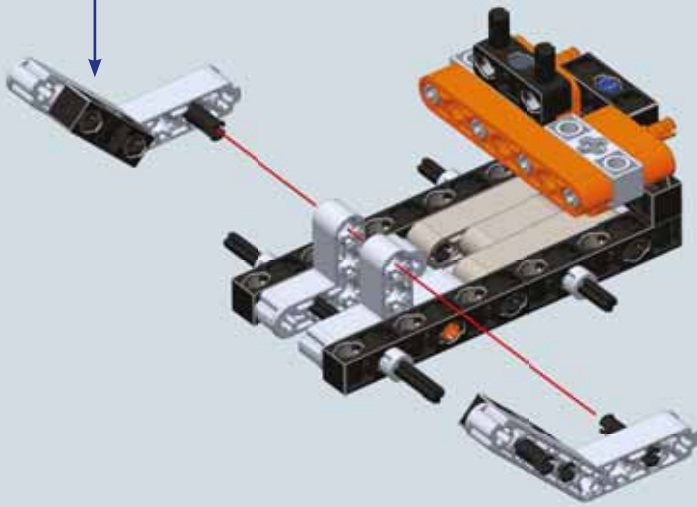
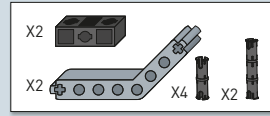

7

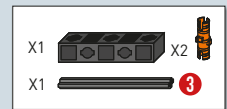
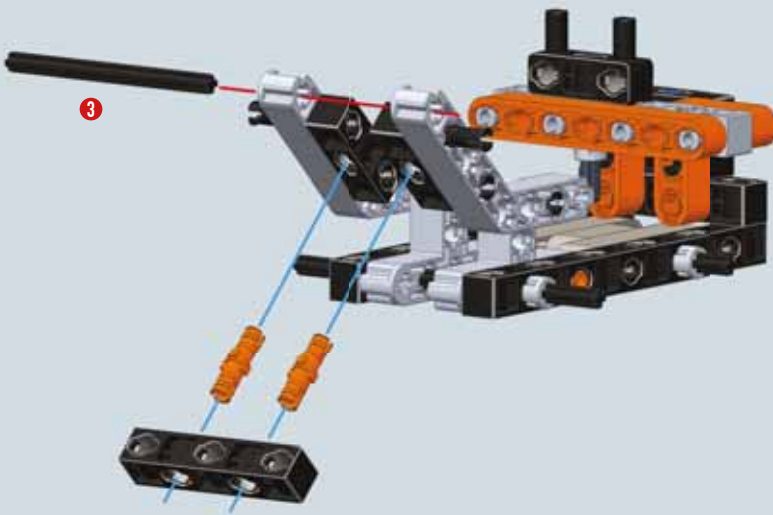

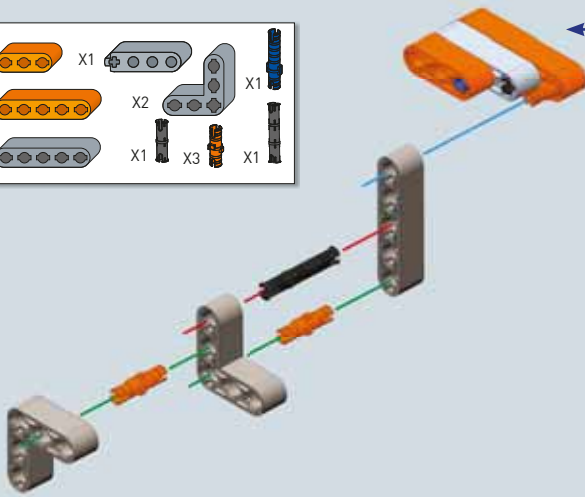
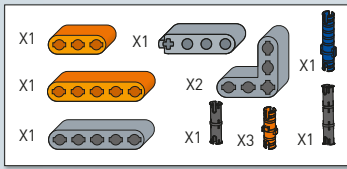

8

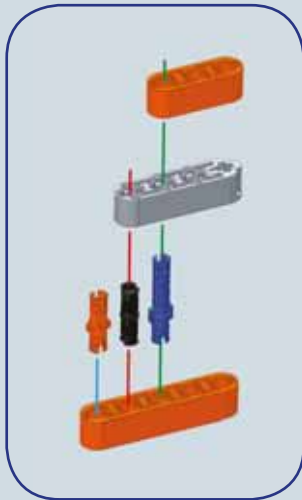
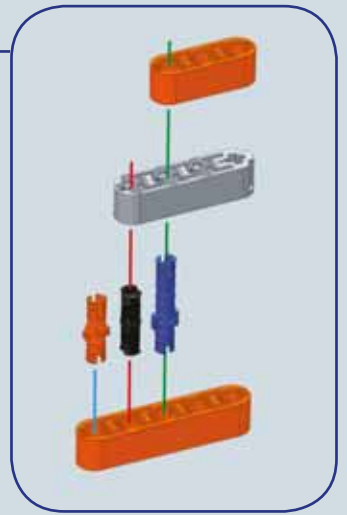

9

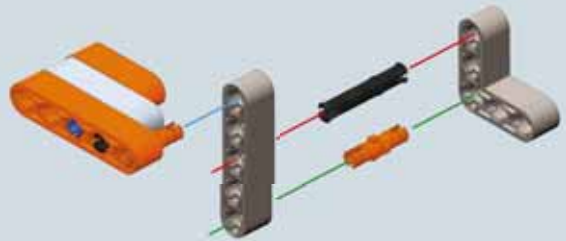
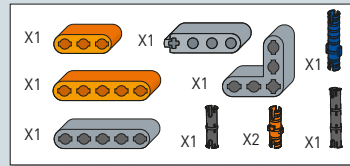

10

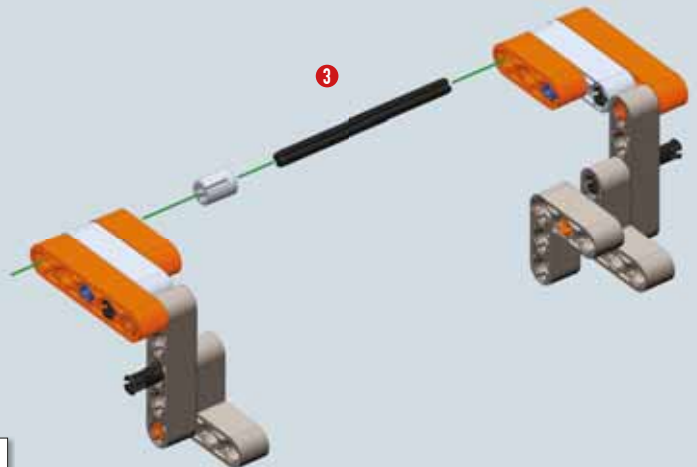
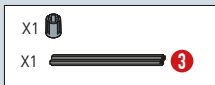

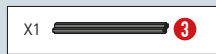
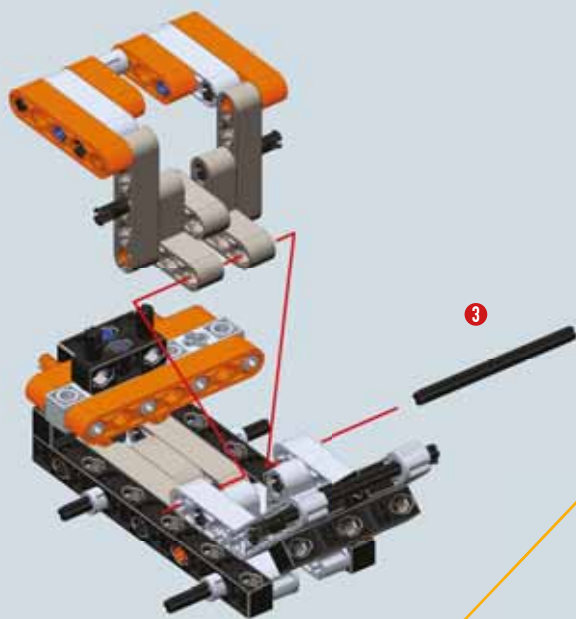

3

1:1

3

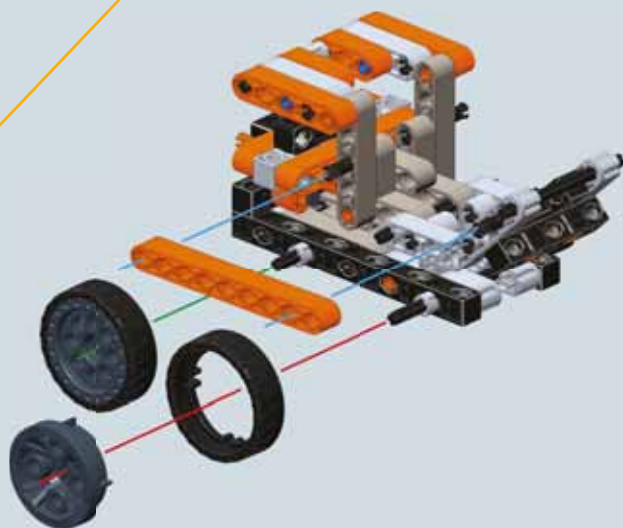

12

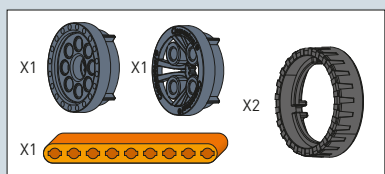

X1

X1

X2

X1

13

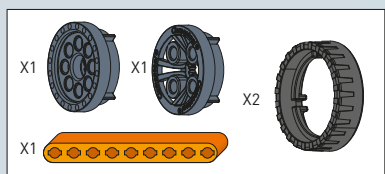
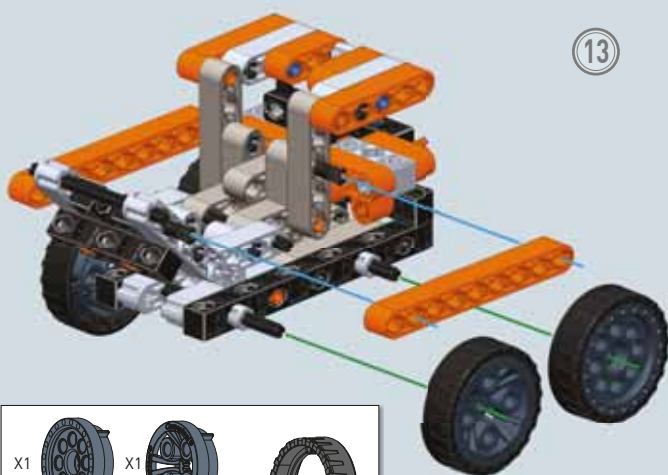

X1

X1

X2

X1



Modelo final



Notas técnicas y curiosidades

El camión es un vehículo diseñado para el transporte de mercancías. Puede tener de 4 a 6 ruedas y es impulsado por potentes motores diésel. En esta tarea lo que vamos a construir es un tractocamión; es decir, un vehículo destinado exclusivamente al movimiento de semirremolques con los que una vez enganchado, forma unidades complejas denominadas camiones articulados. La diferencia entre un camión y un tractocamión consiste básicamente en el hecho de que en el segundo no se puede cargar la mercancía directamente.

El morro plano, típico de los camiones europeos, se debe a las normas rigurosas sobre las dimensiones de los vehículos, establecidas por cuestiones de seguridad y gestión del tráfico.

En otras épocas, en lugar de los tractocamiones se utilizaban verdaderos tractores agrícolas equipados con carrocería y neumáticos ligeramente modificados con respecto a los modelos originales.

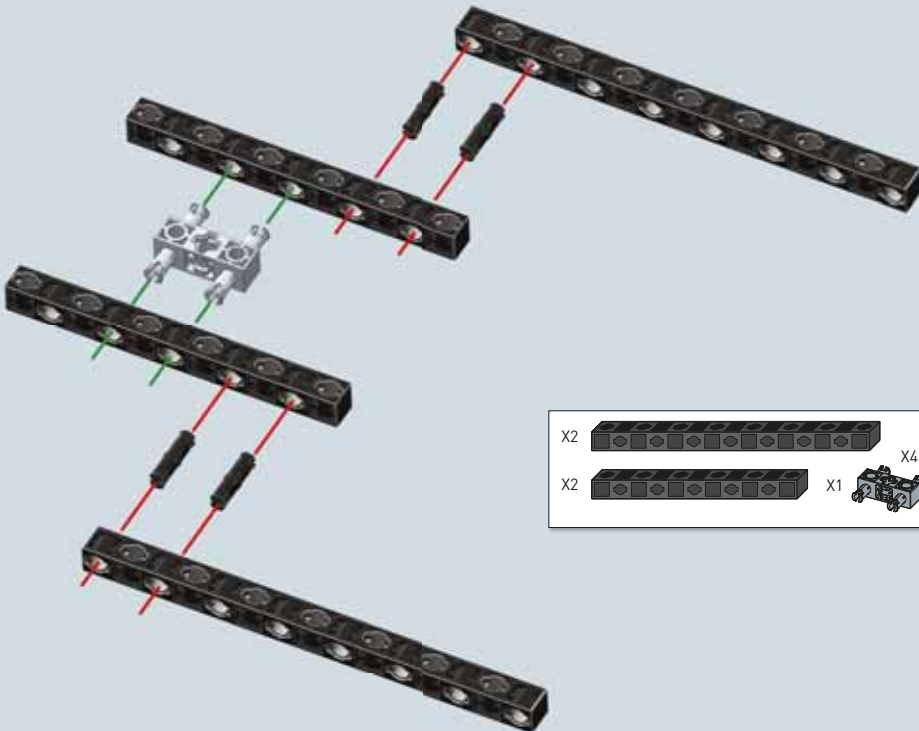

X2		X4	
X2		X1	

1

2

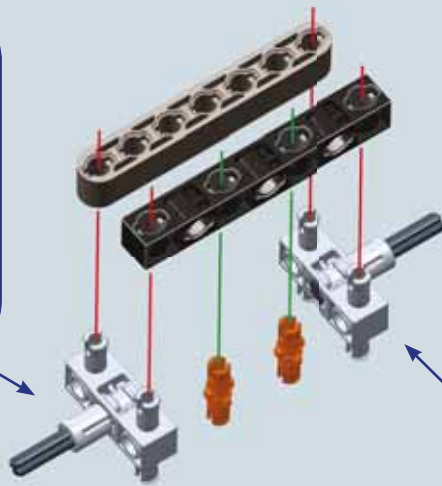

- | | | | |
|----|--|----|--|
| X1 | | X2 | |
| X1 | | X2 | |
| X2 | | X2 | |

3

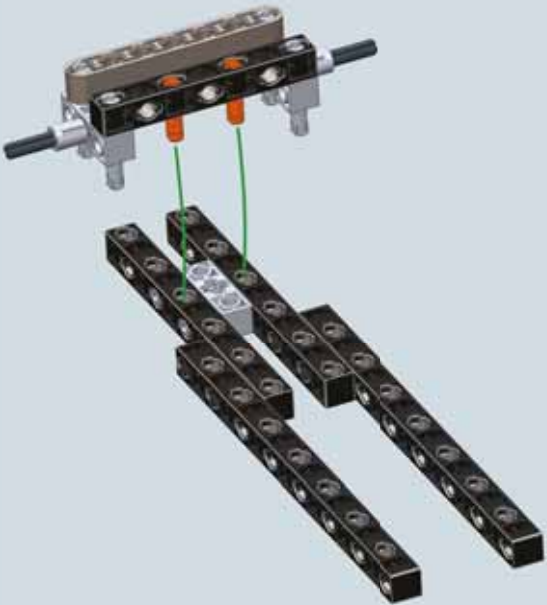

- | | | | | | |
|----|--|----------|--|----|--|
| X1 | | X1 | | X1 | |
| X1 | | 6 | | | |

4

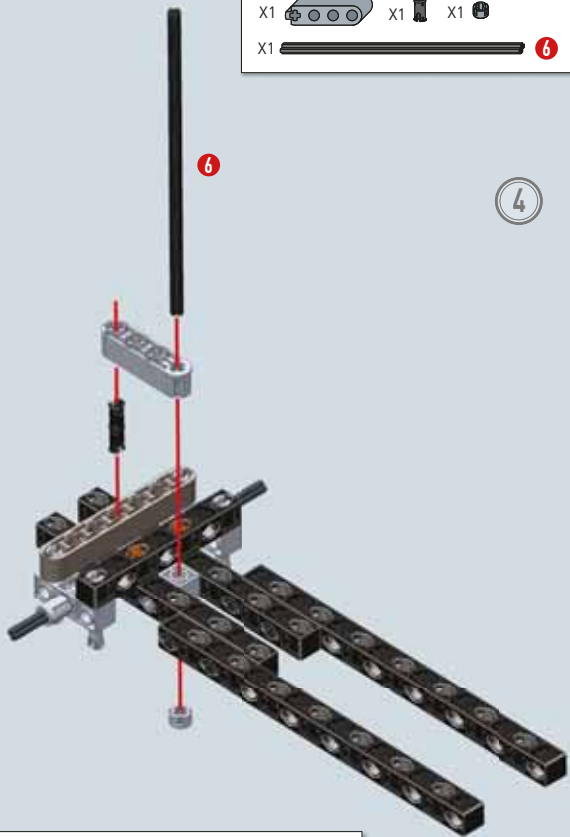

- | | | |
|-----|--|----------|
| 1:1 | | 6 |
|-----|--|----------|

5

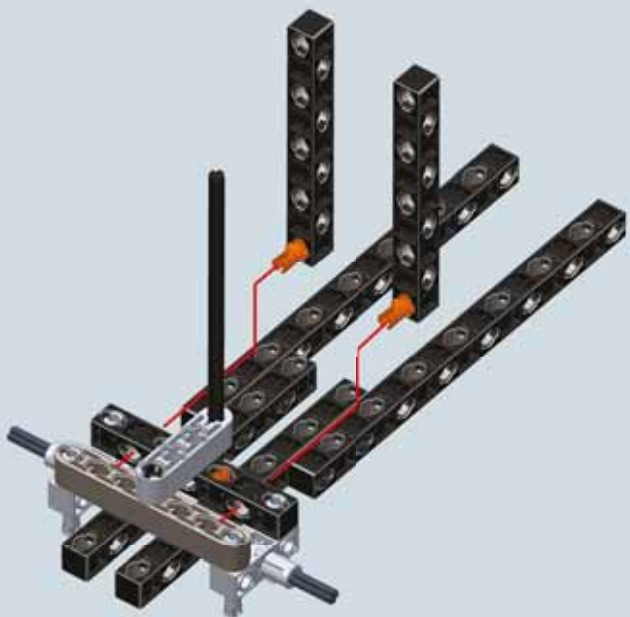

6

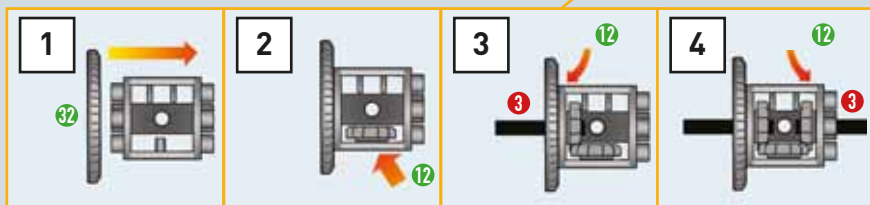
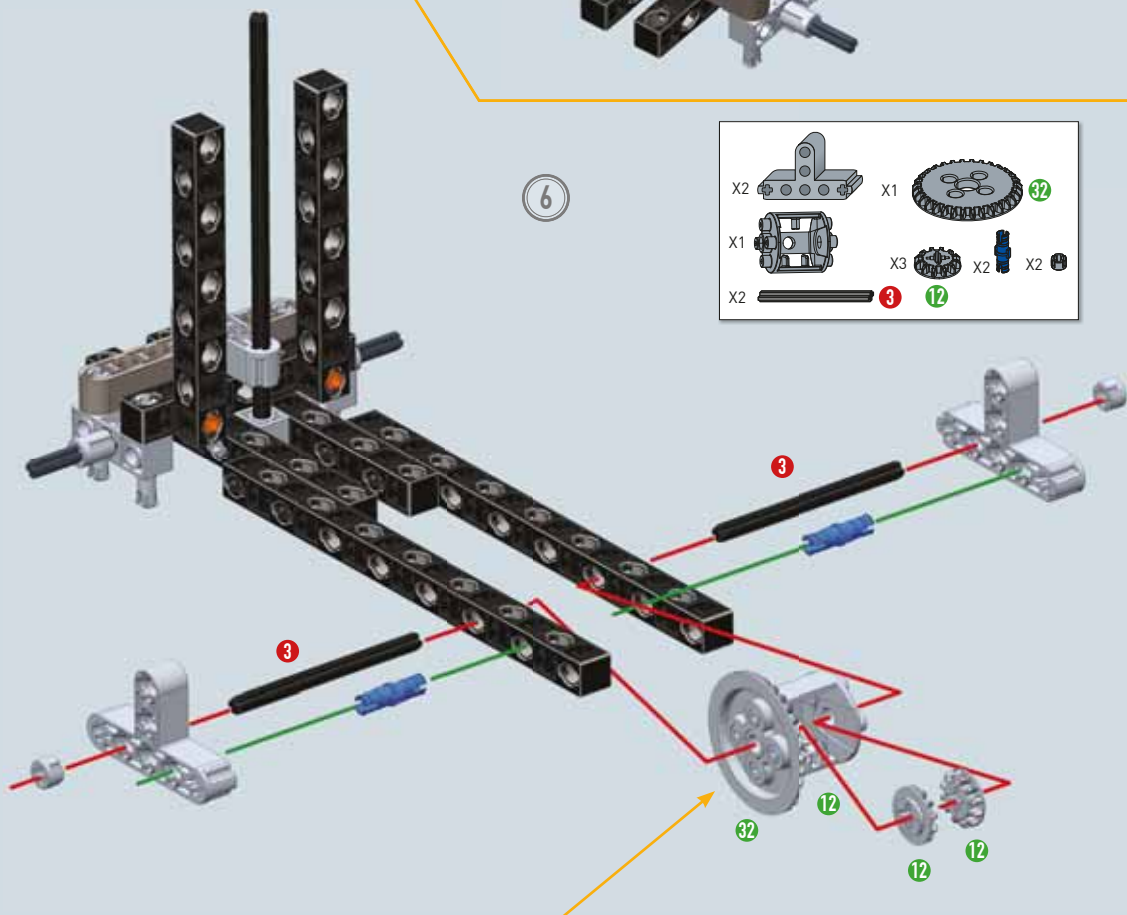
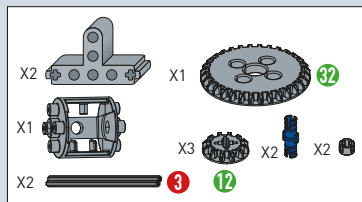

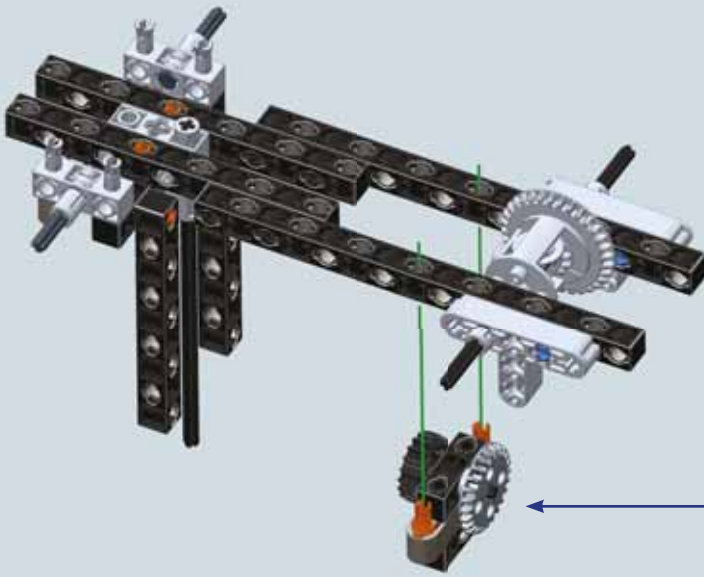

- | | | | | | |
|----|--|----|--|----|--|
| X1 | | X1 | | X1 | |
| X2 | | X2 | | X1 | |
| X1 | | X2 | | X1 | |

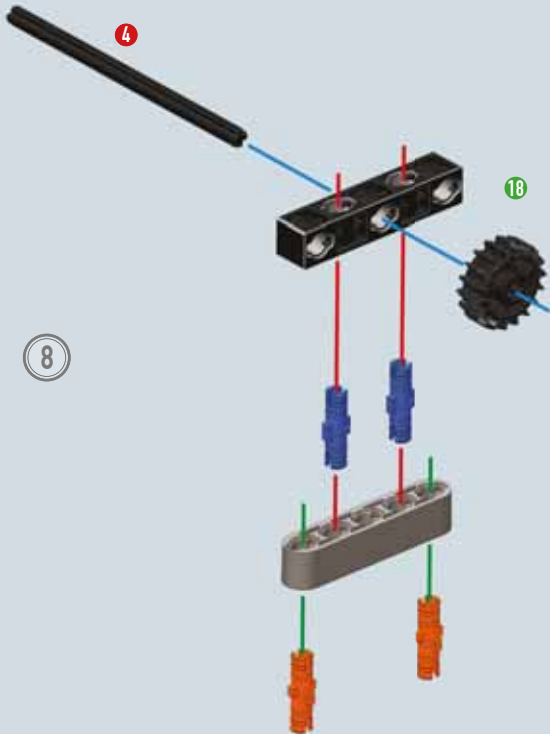
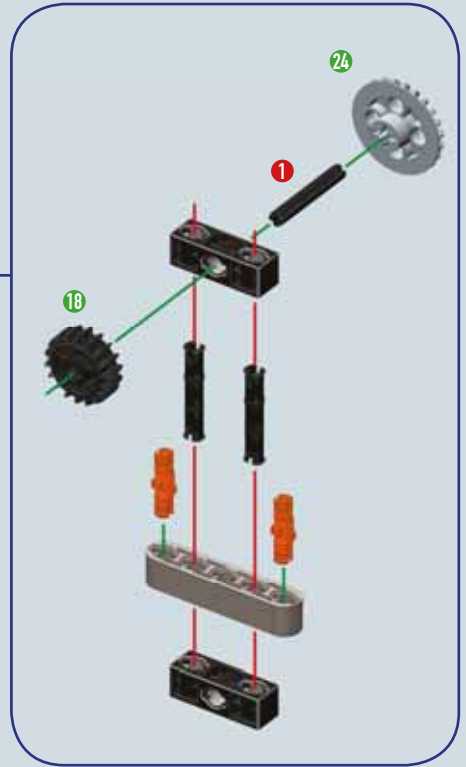

- | | | | | | |
|----|--|----|--|----|--|
| X1 | | X1 | | X2 | |
| X1 | | X1 | | X2 | |
| X1 | | X1 | | X2 | |



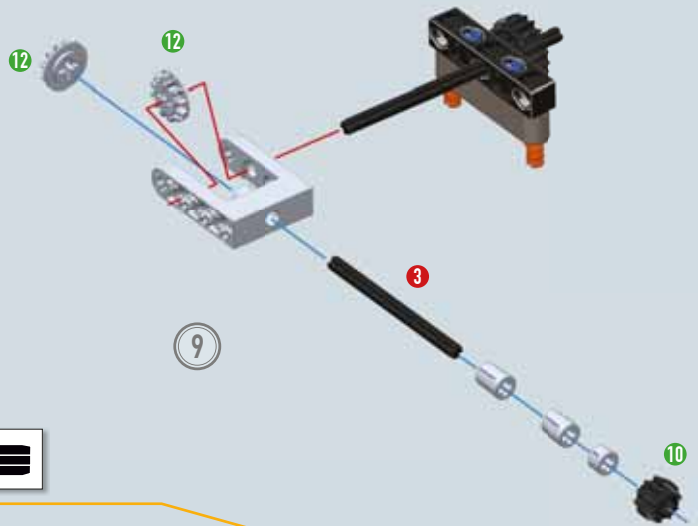
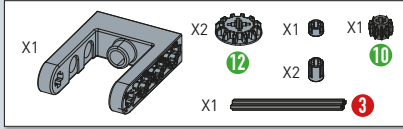
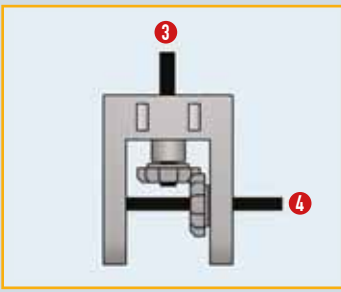

9

10

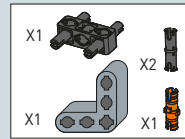
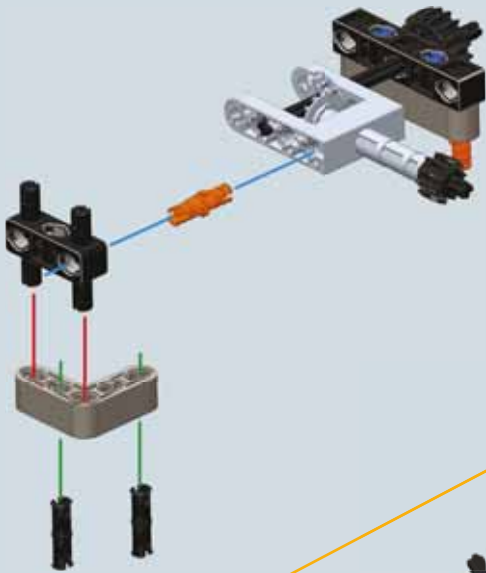

11

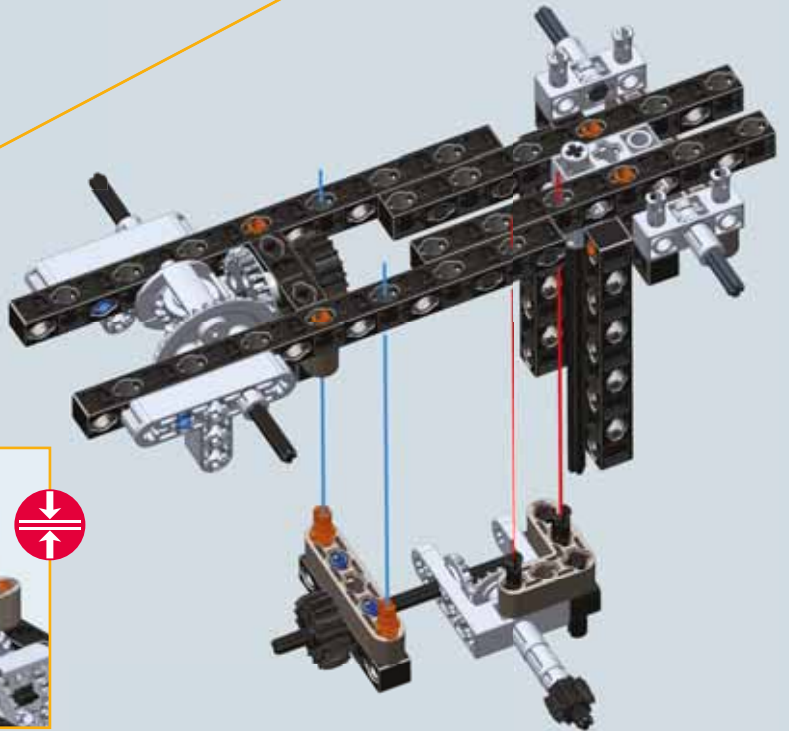

12

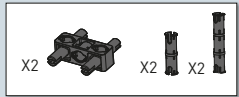
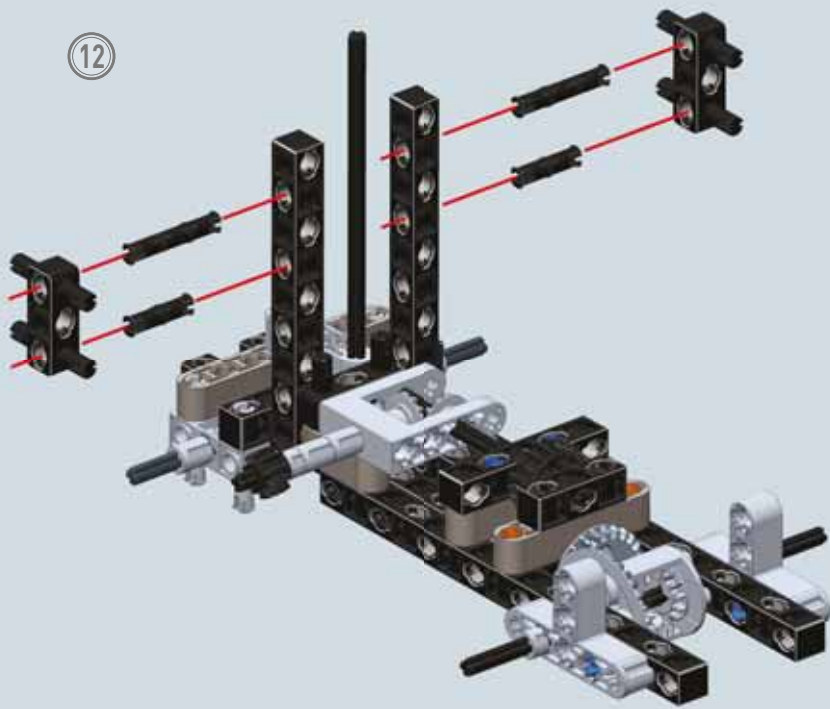

13

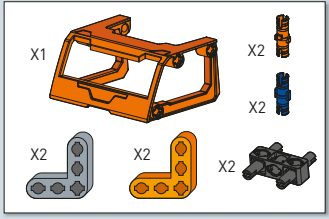
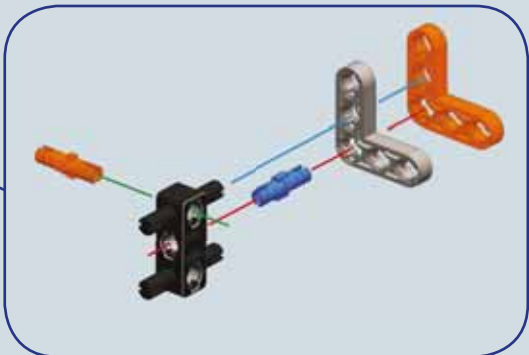
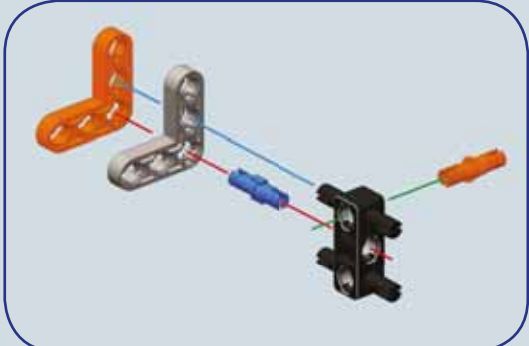
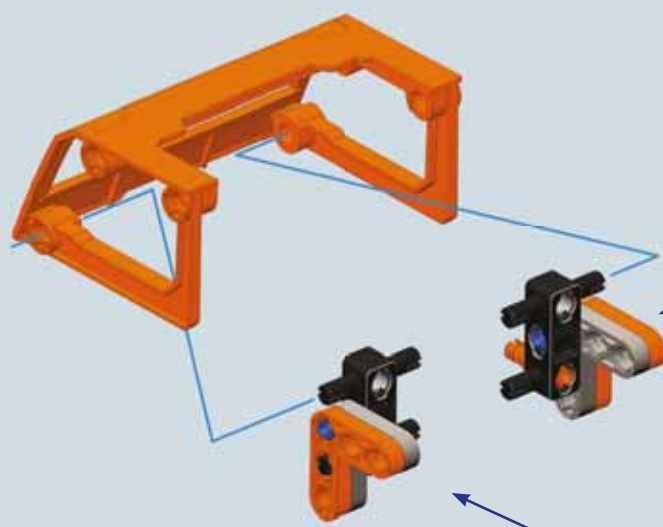

14

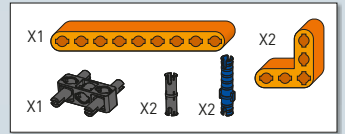
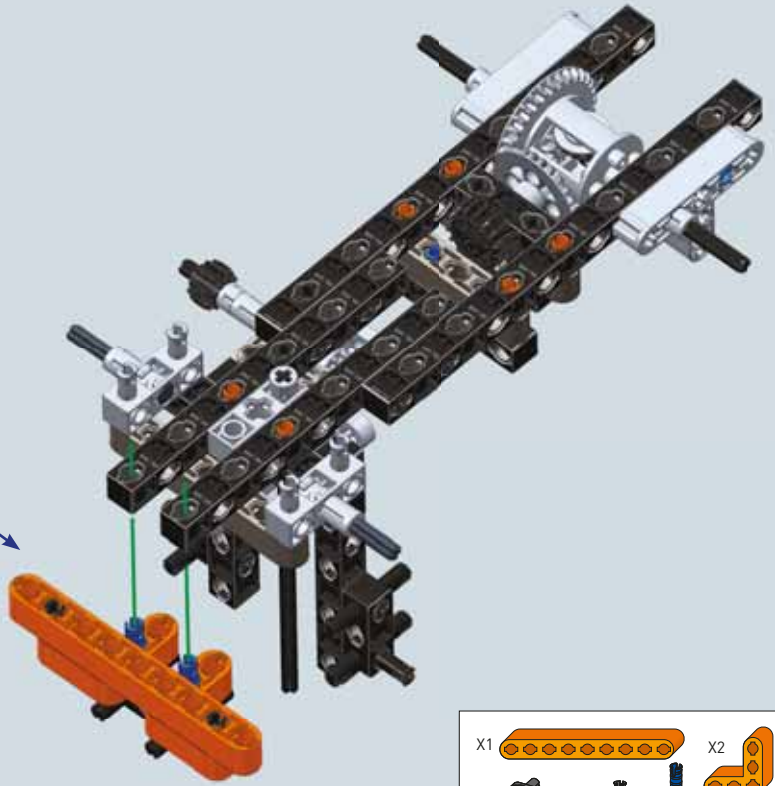
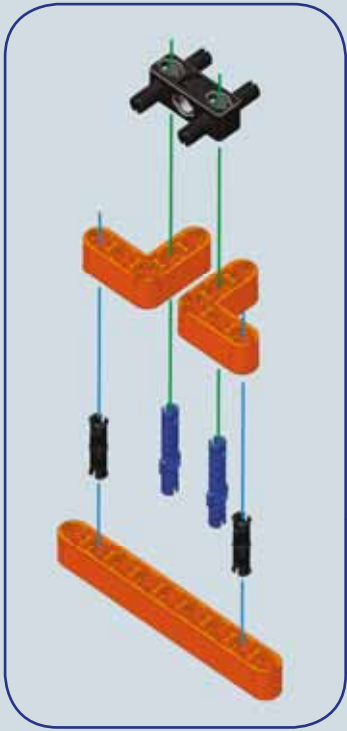

15

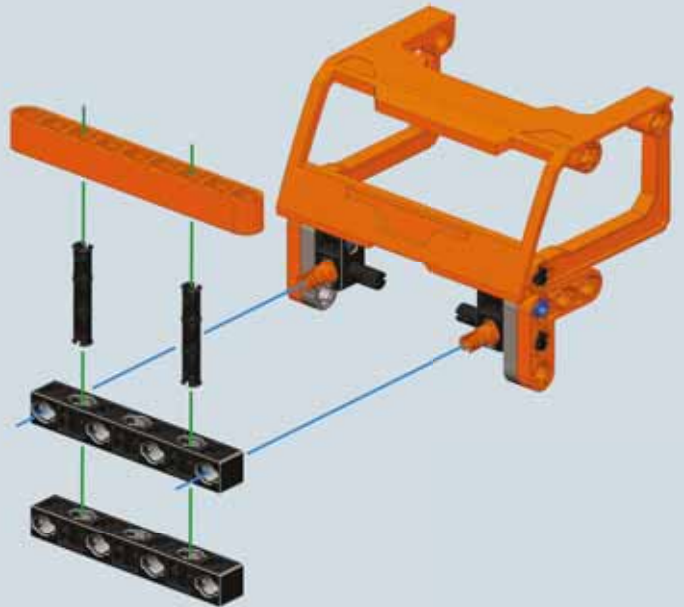
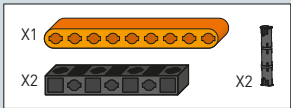

16

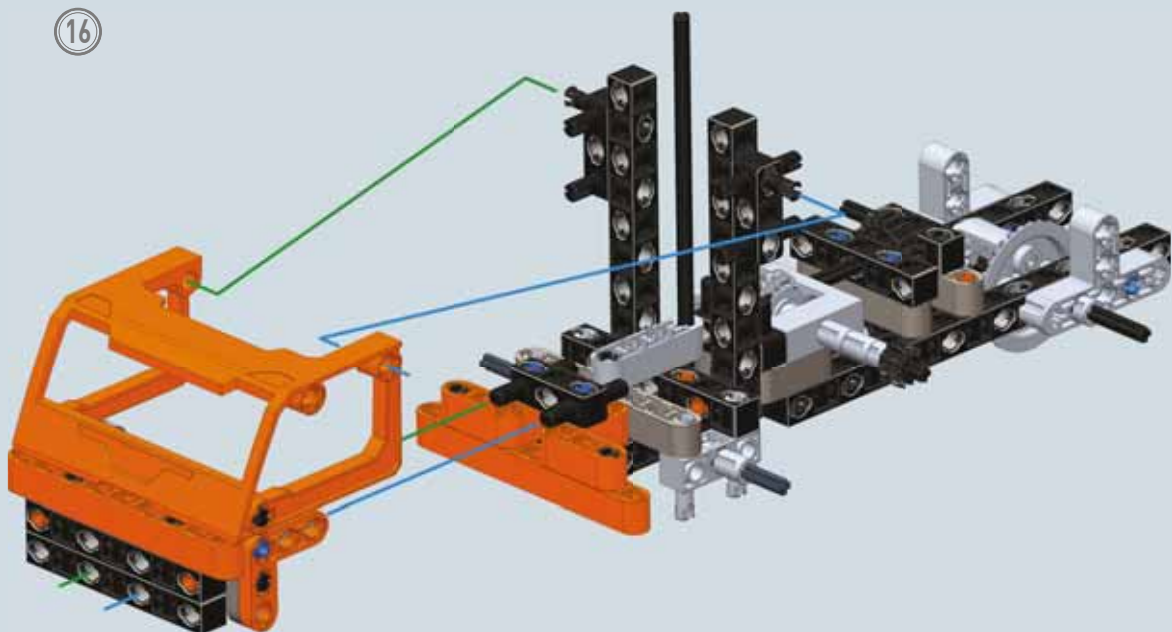

17

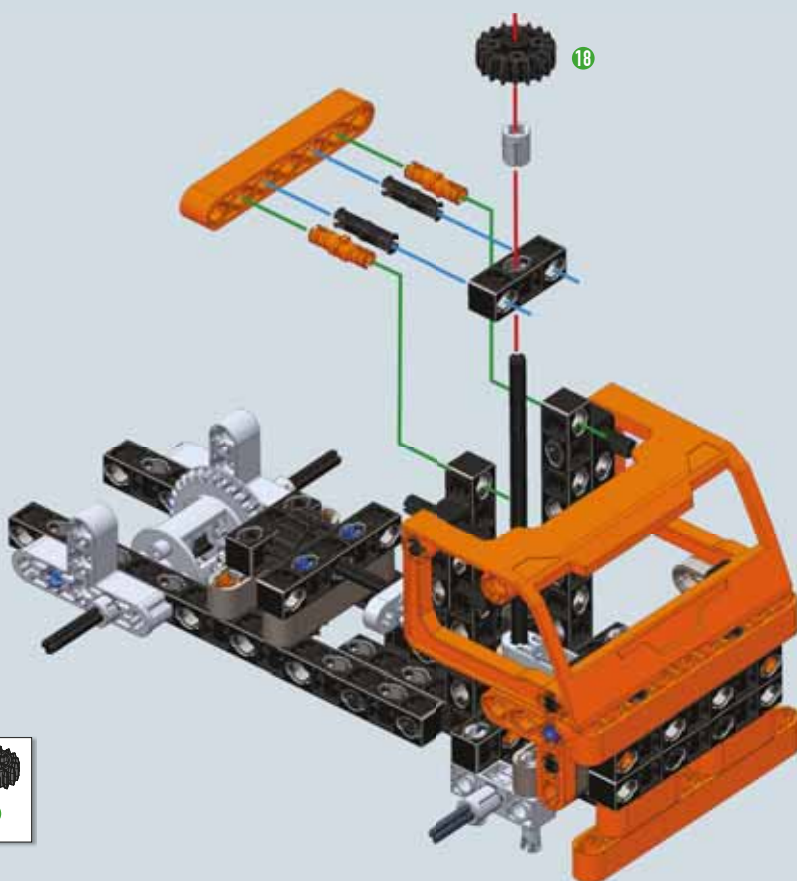

- | | | | |
|----|----|----|----|
| X1 | | X1 | |
| X1 | | X1 | |
| | X2 | | X2 |
| | | | |

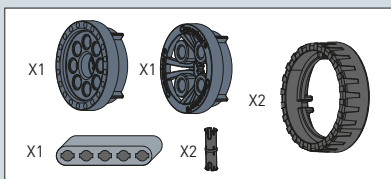
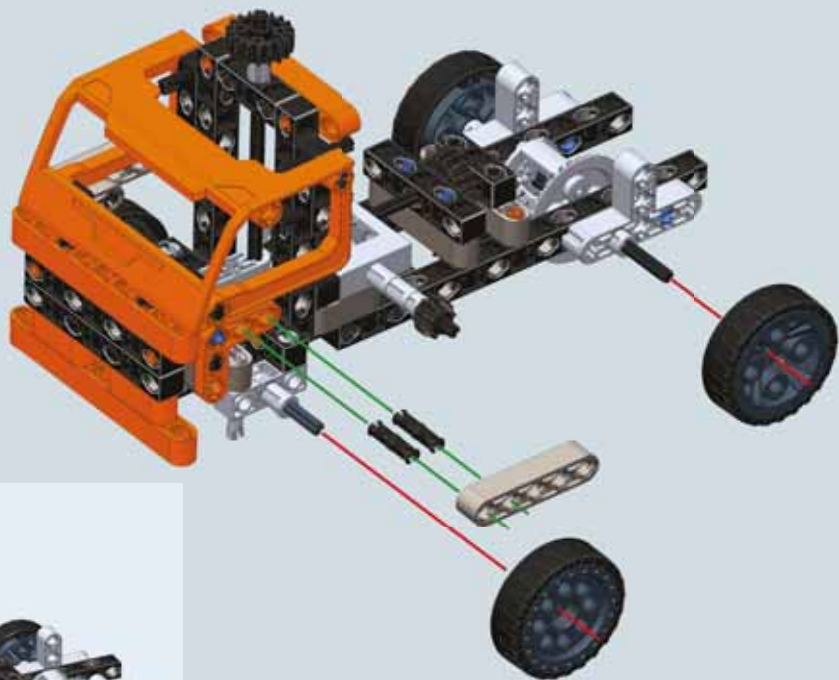
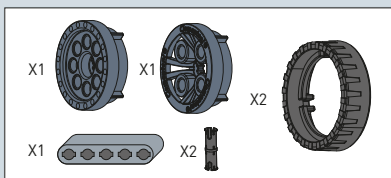
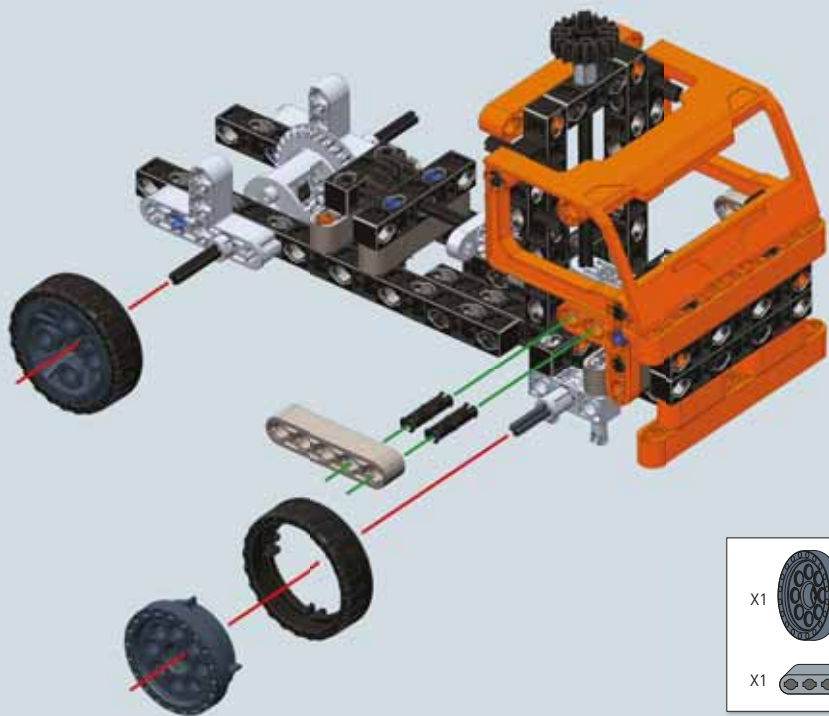

Modelo final

5 Camión con pinza para troncos



Notas técnicas y curiosidades

La pinza hidráulica es una herramienta de sujeción constituida por una tenaza accionada por uno o varios cilindros hidráulicos. También el brazo telescópico que la une al camión se vale de los mismos actuadores hidráulicos para el movimiento. Este tipo de herramienta se utiliza en el sector forestal para cargar la leña destinada al comercio o para despejar zonas obstruidas por troncos y ramas.

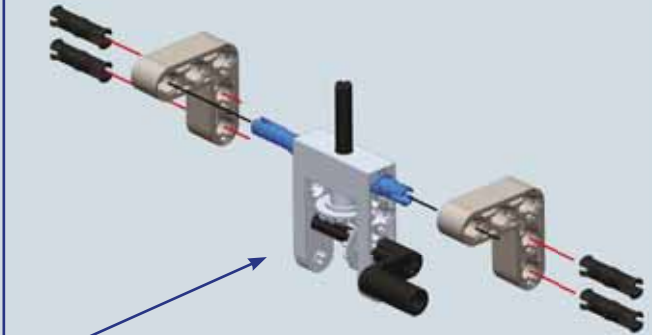
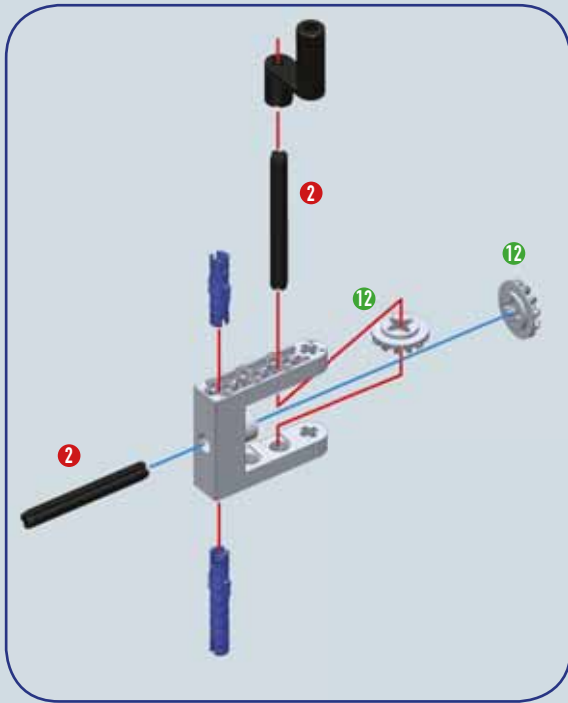

①

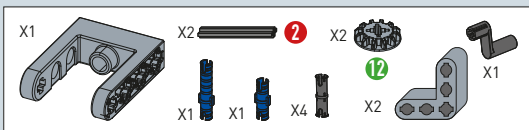
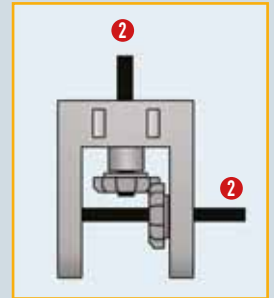



Modelo ensamblado en la tarea 4

2

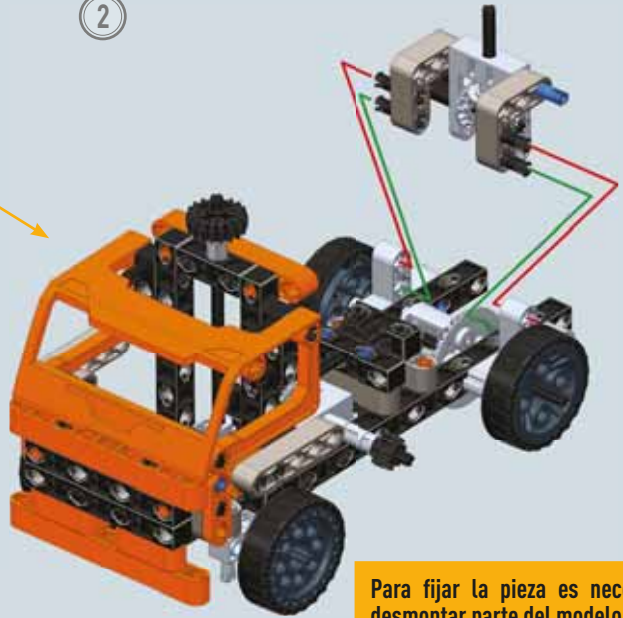

Para fijar la pieza es necesario desmontar parte del modelo.

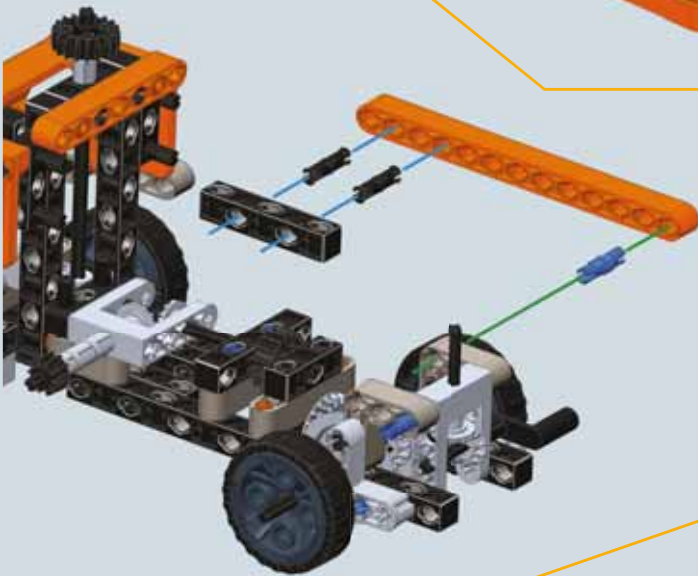

3

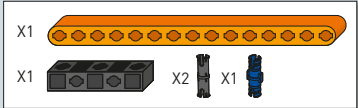

4

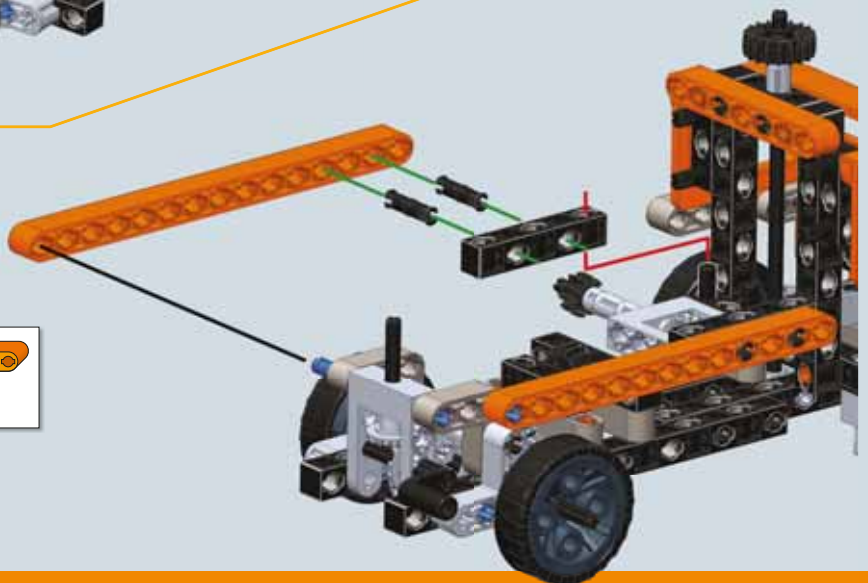
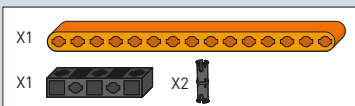

5



6

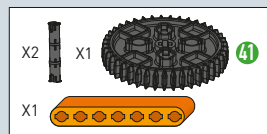
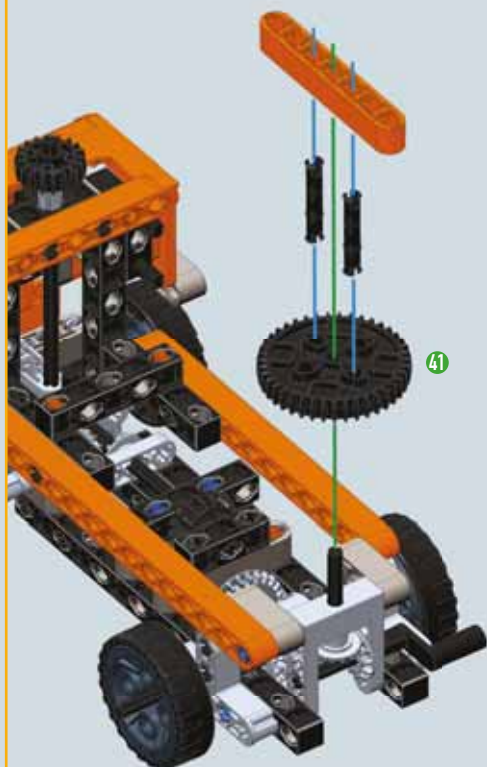

7

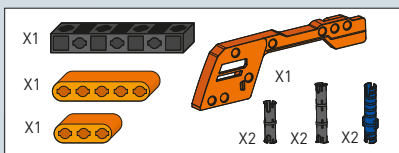
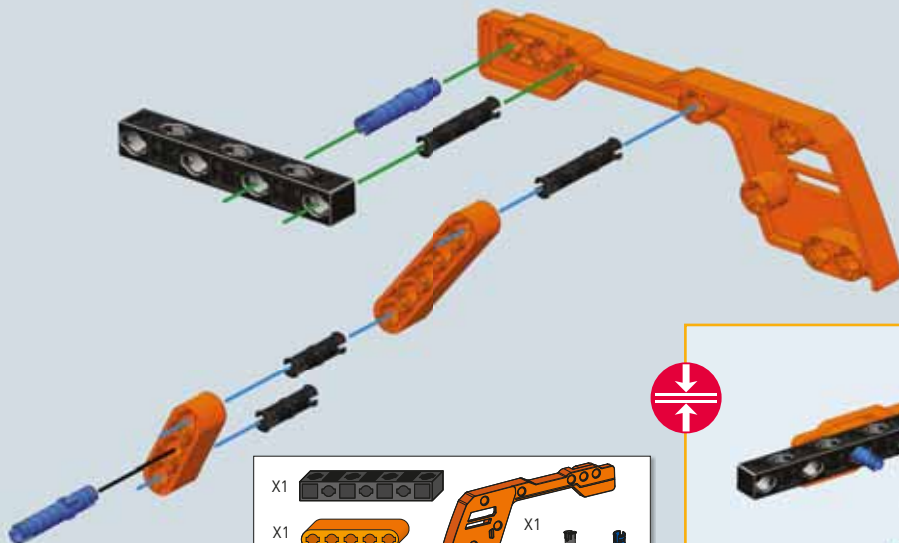

8

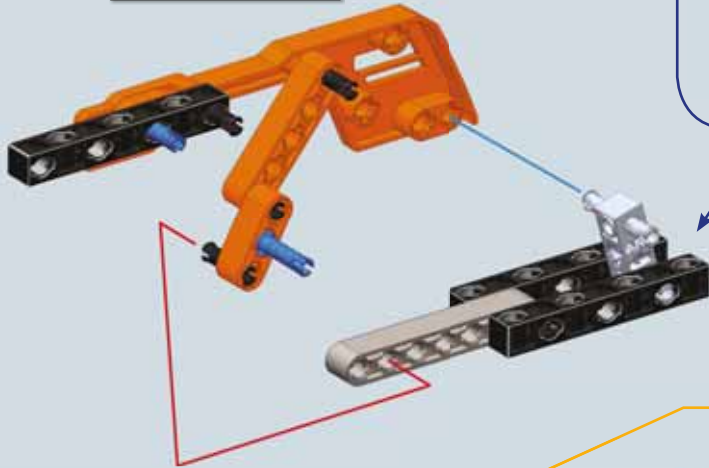
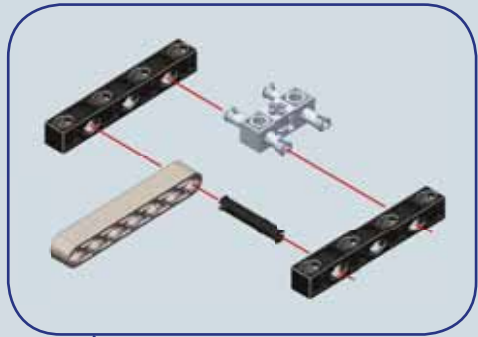
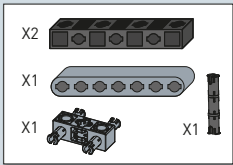

9

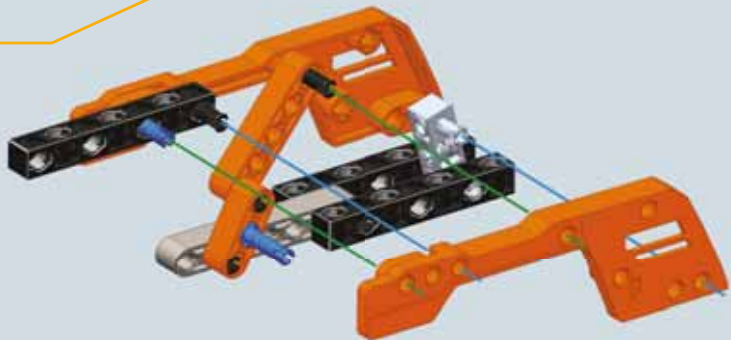
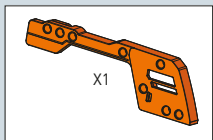

10



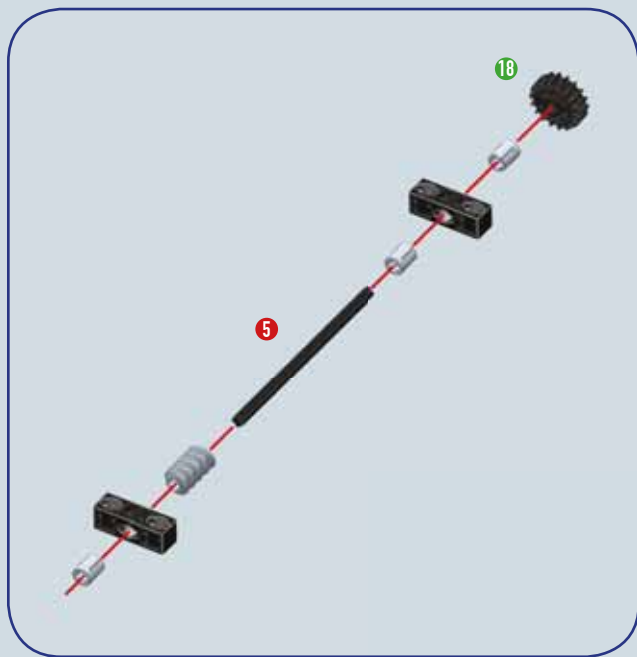

11



- | | | | | | |
|----|--|----|--|----|--|
| X2 | | X3 | | X1 | |
| X2 | | | | | |
| X1 | | | | | |
| X1 | | X3 | | X1 | |

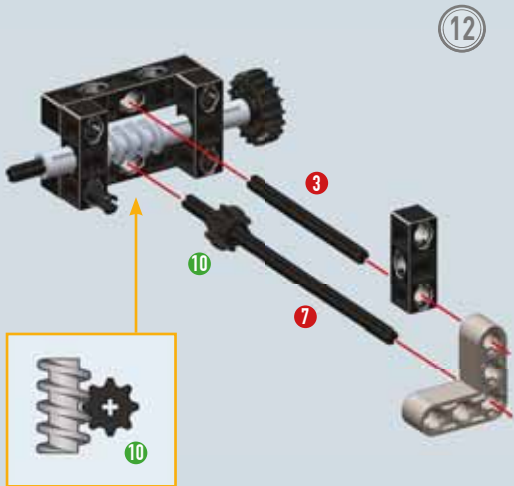

12

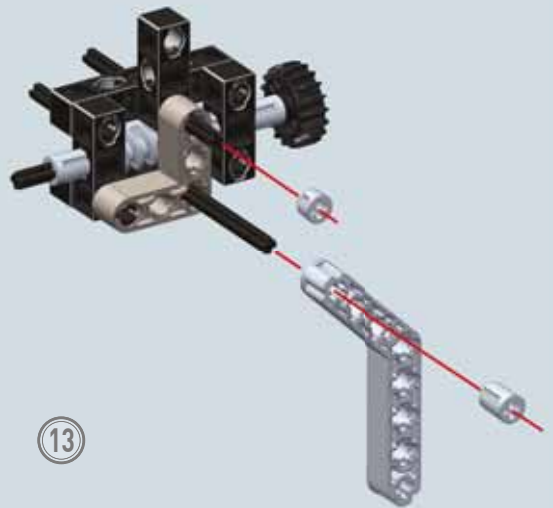

13

- | | | | | | |
|----|--|----|--|----|--|
| X1 | | X1 | | X1 | |
| X1 | | | | | |
| X1 | | | | | |



- | | | | |
|----|--|----|--|
| X1 | | X1 | |
| X1 | | | |



14

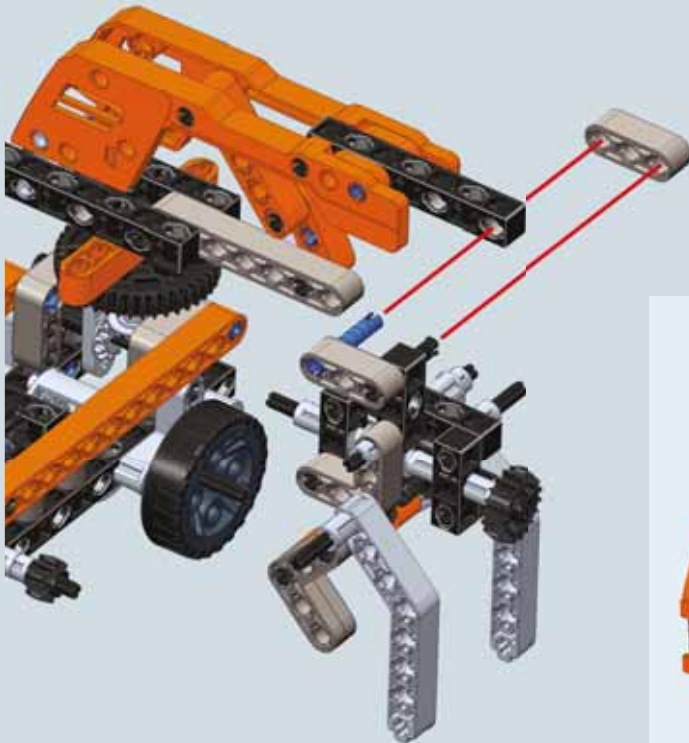
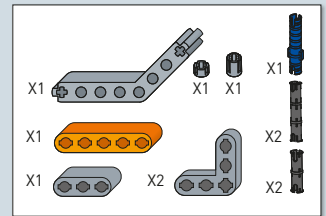
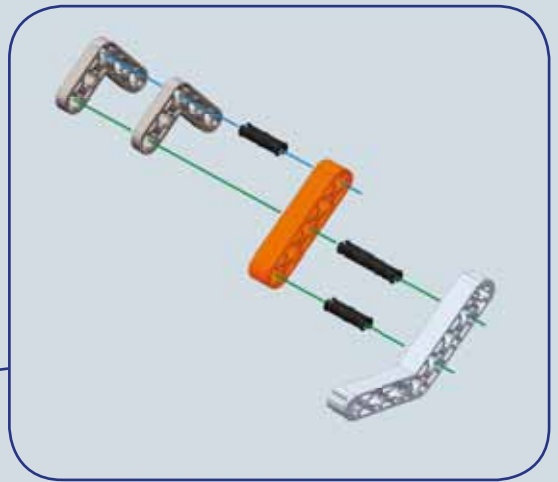
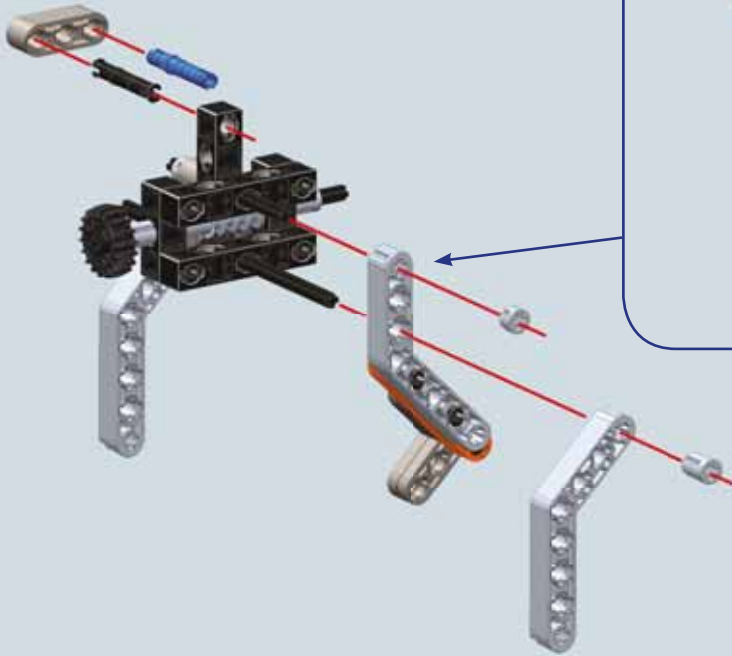

15

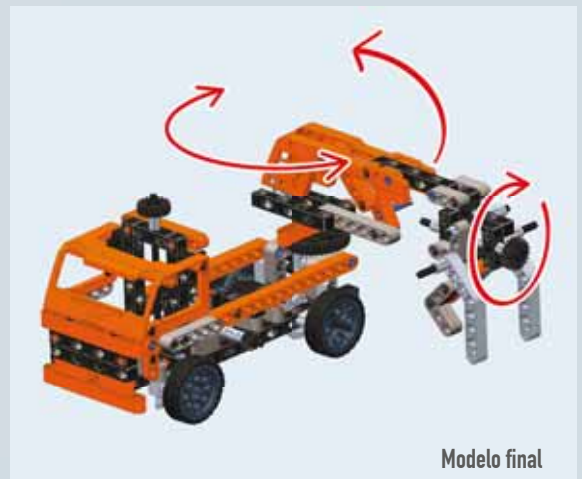

Modelo final

6 Camión con volquete



Notas técnicas y curiosidades

El camión con volquete es un autocamión, puesto que puede transportar cargas por sí mismo. Por lo general se usa para el transporte de cargas «a granel», como arena, grava o basura. Del movimiento del cajón se encargan, también en este caso, los pistones hidráulicos.



- X1
- X1
- X1
- X1
- X1
- X1
- X2
- X2
- X2
- X2

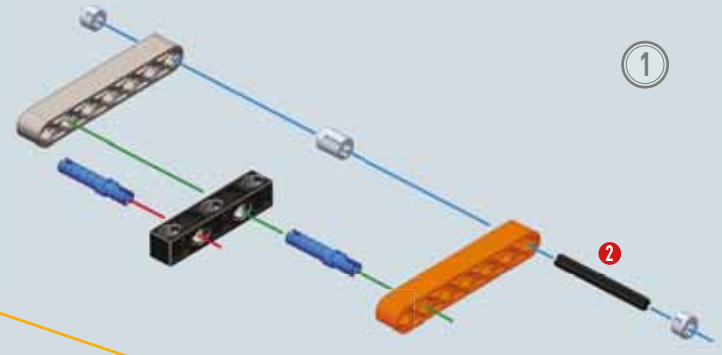

1

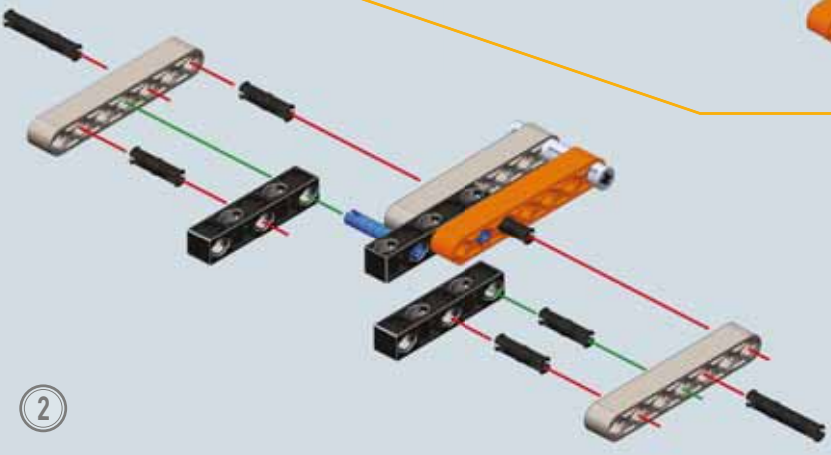

2

- X2
- X2
- X2
- X5

- X2
- X2
- X2



3

- 1:1

5

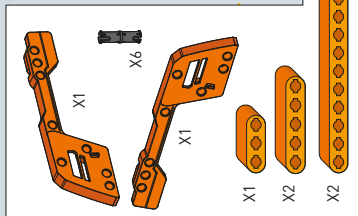
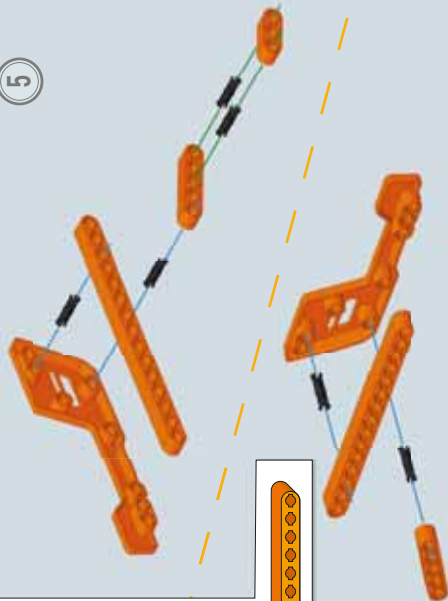

7



1:1

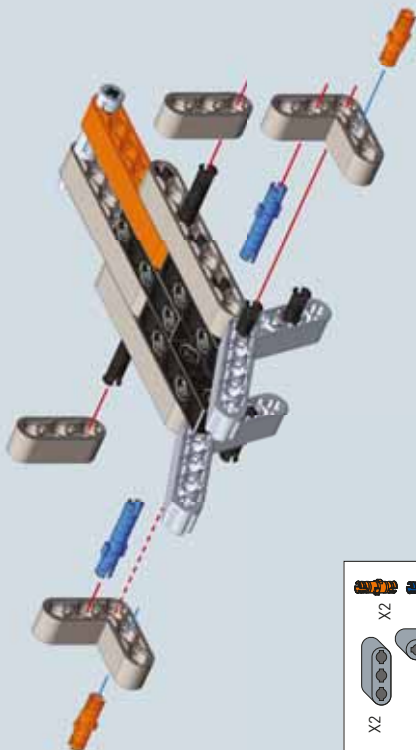

4

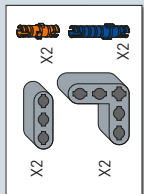

6

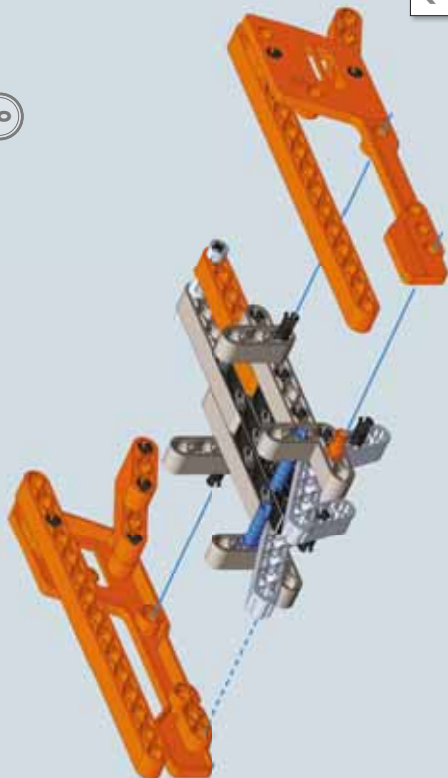



8

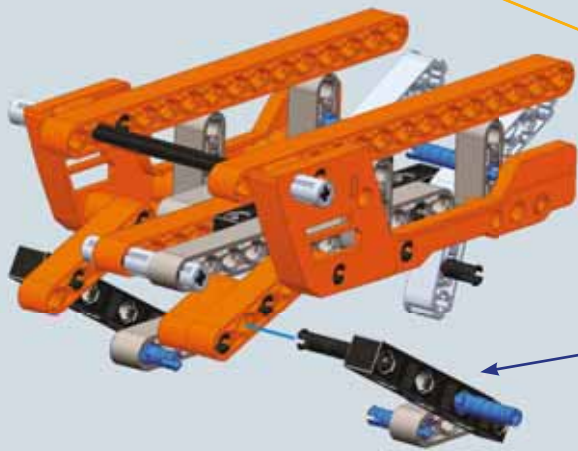
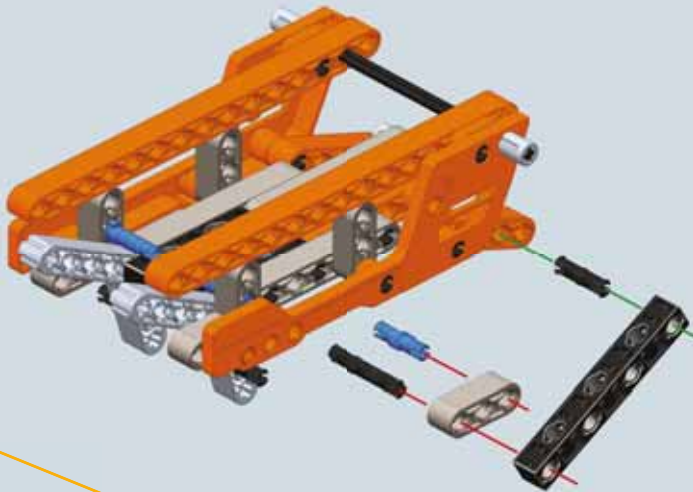

9

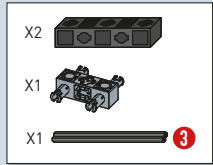
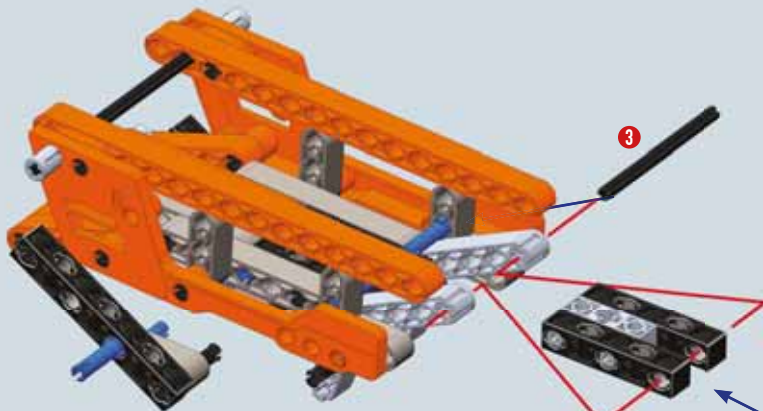
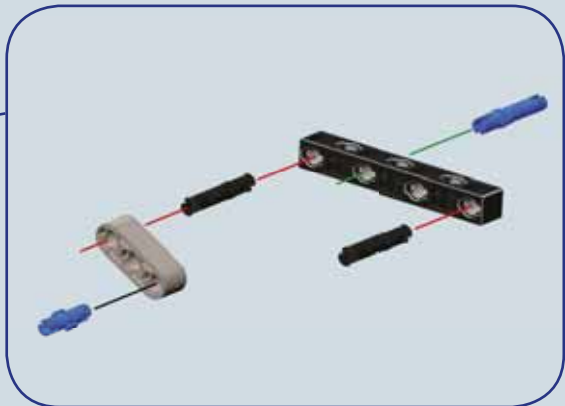

10



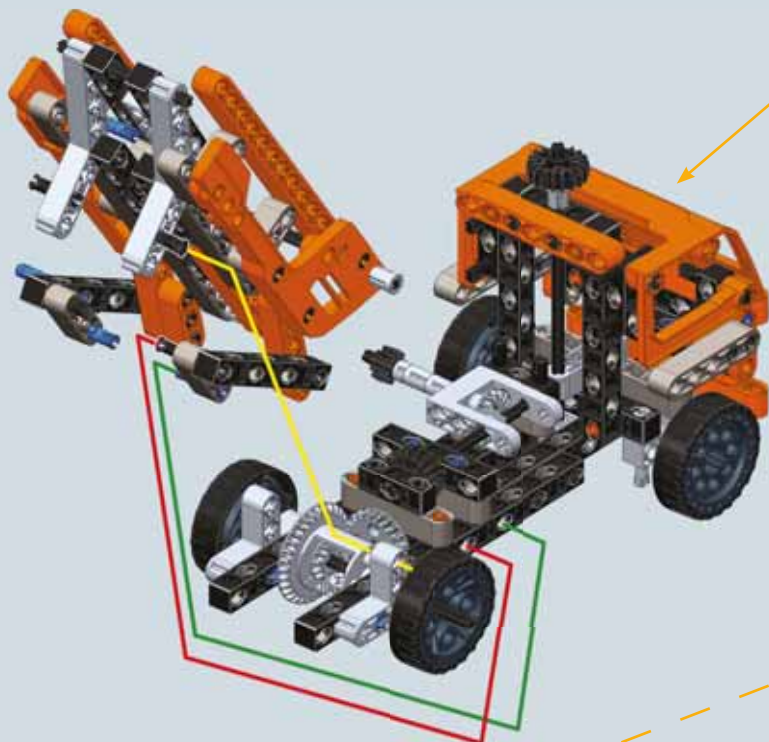

Modelo ensamblado en la tarea 4

11

Para fijar la pieza es necesario
desmontar parte del modelo.

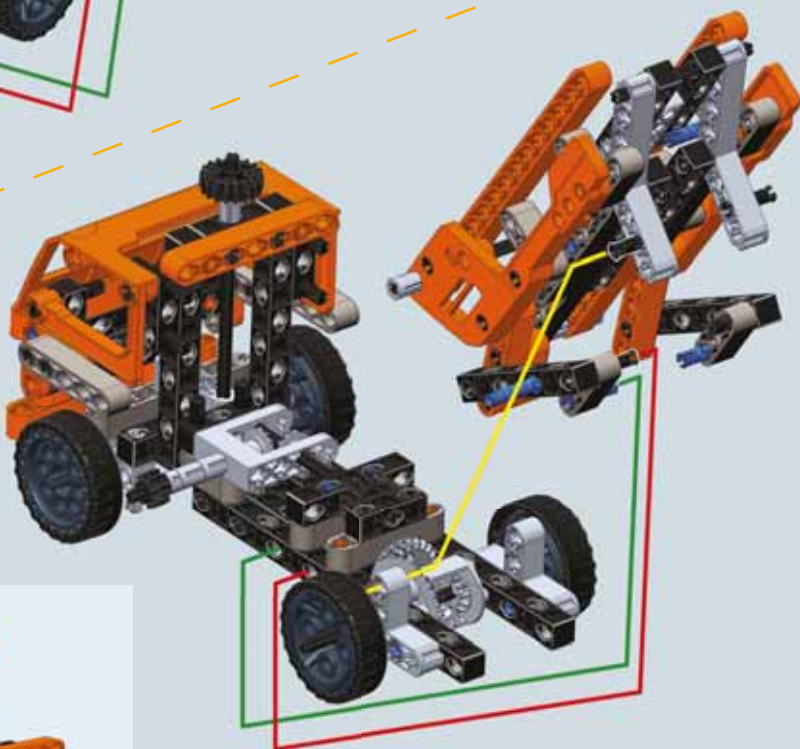

Modelo final



1

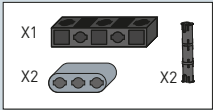
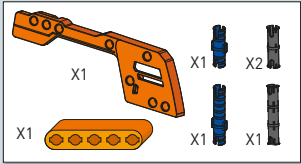
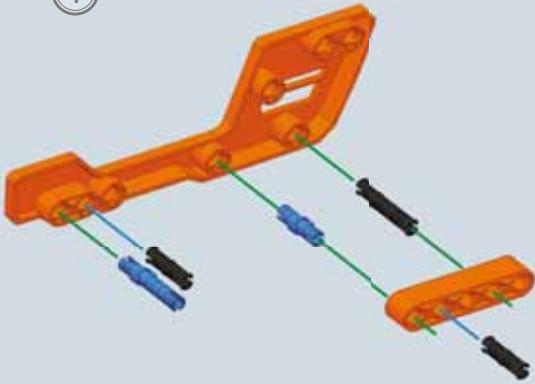

2

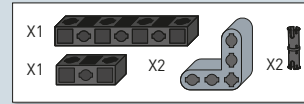
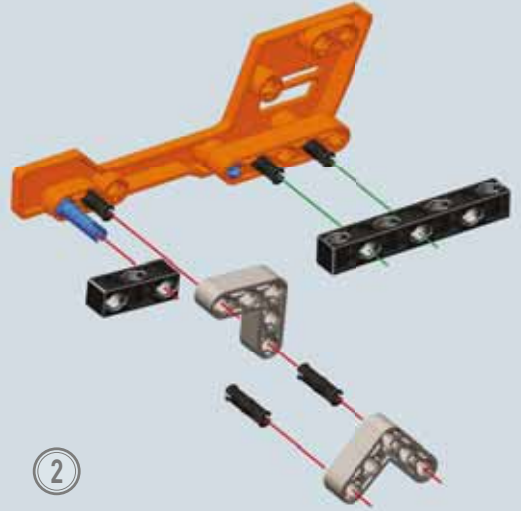

3

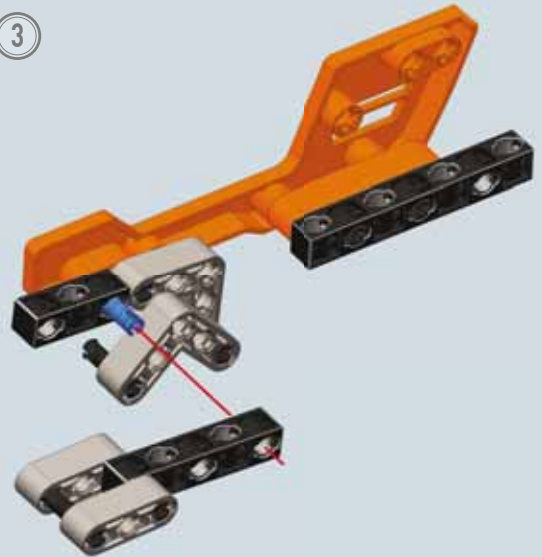

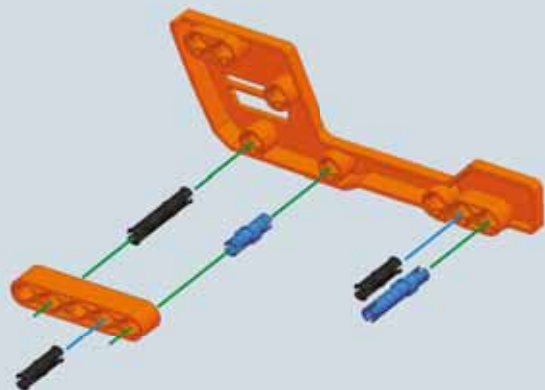

4

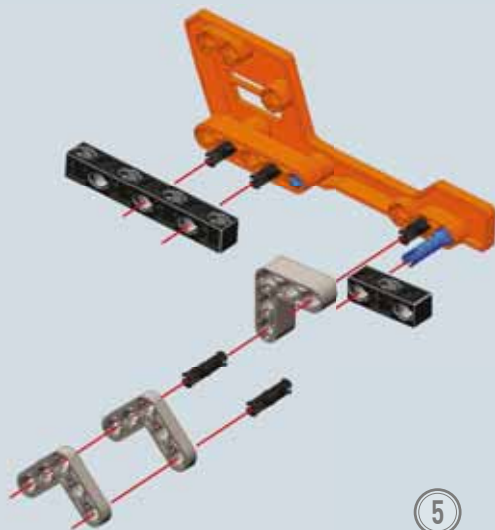
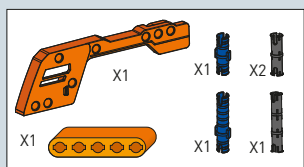

5

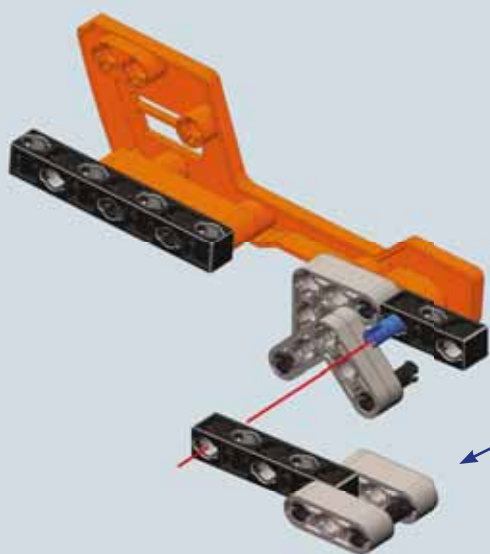
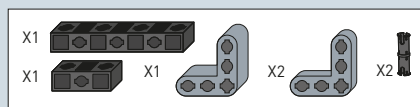

6

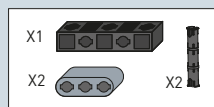
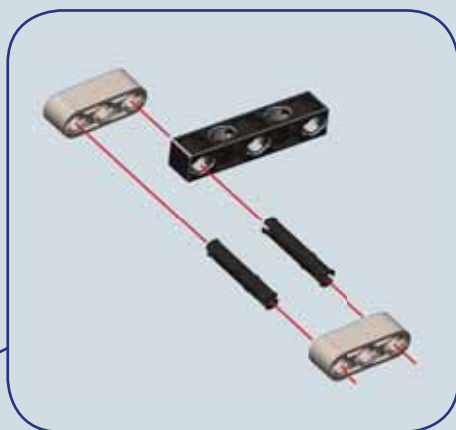

Notas técnicas y curiosidades

La grúa es un vehículo realizado para prestar ayuda en carretera a los vehículos motorizados con dificultades técnicas y para trasladarlos de un lugar a otro. En la mayoría de los casos, se utiliza para recuperar vehículos que, como consecuencia de un accidente, han ido a parar a lugares de difícil acceso.

7

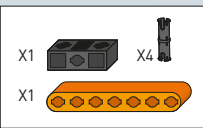
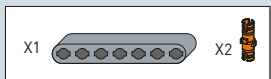

8

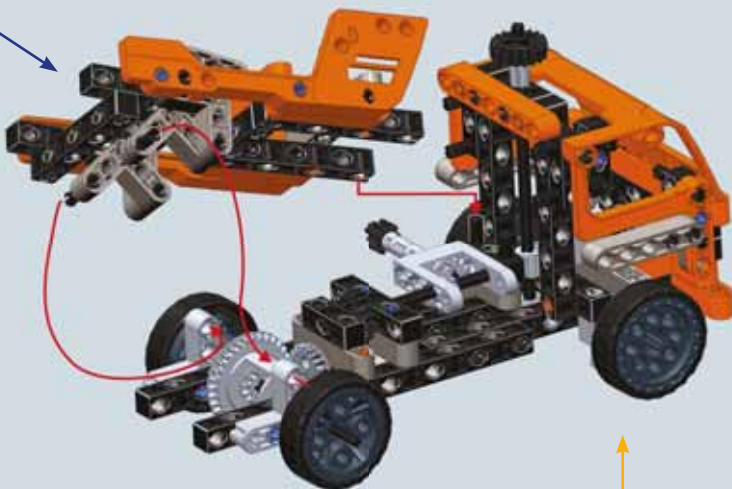
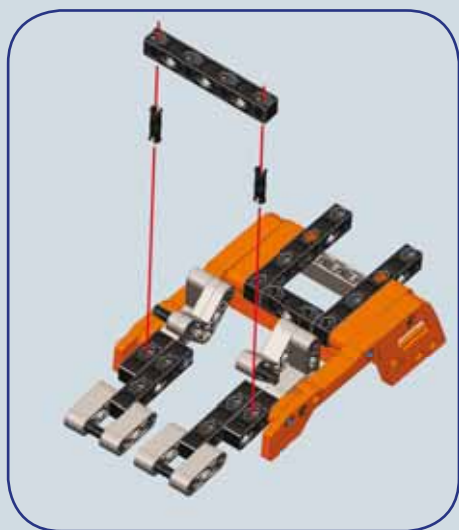

Para fijar la pieza es necesario desmontar parte del modelo.

9



Modelo final



Modelo ensamblado en la tarea 4



1

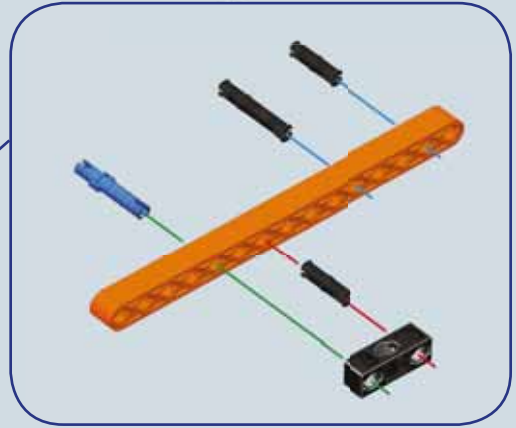
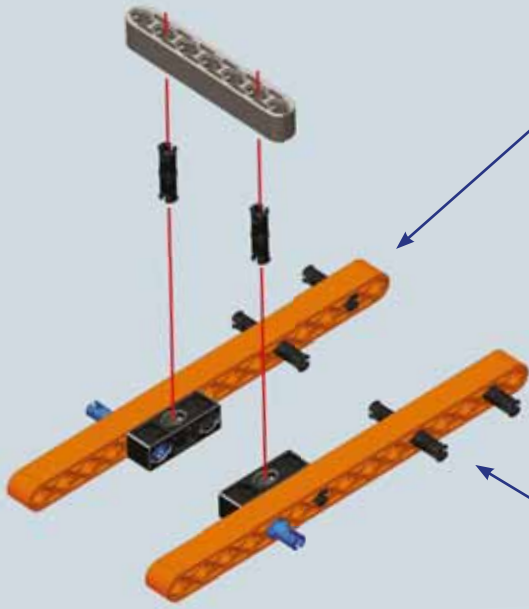

- X2
- X2
- X2
- X6
- X2
- X1

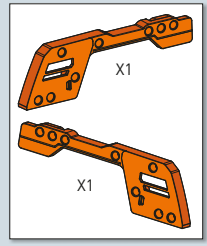
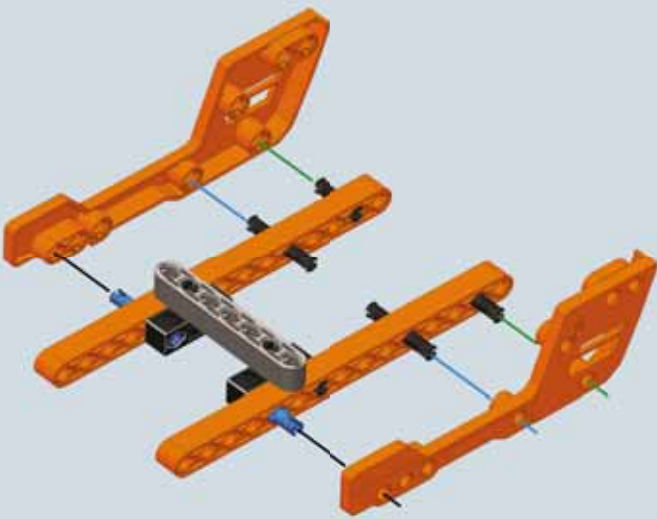

2



Modelo ensamblado en la tarea 4

3

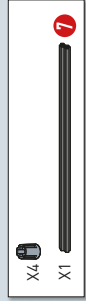
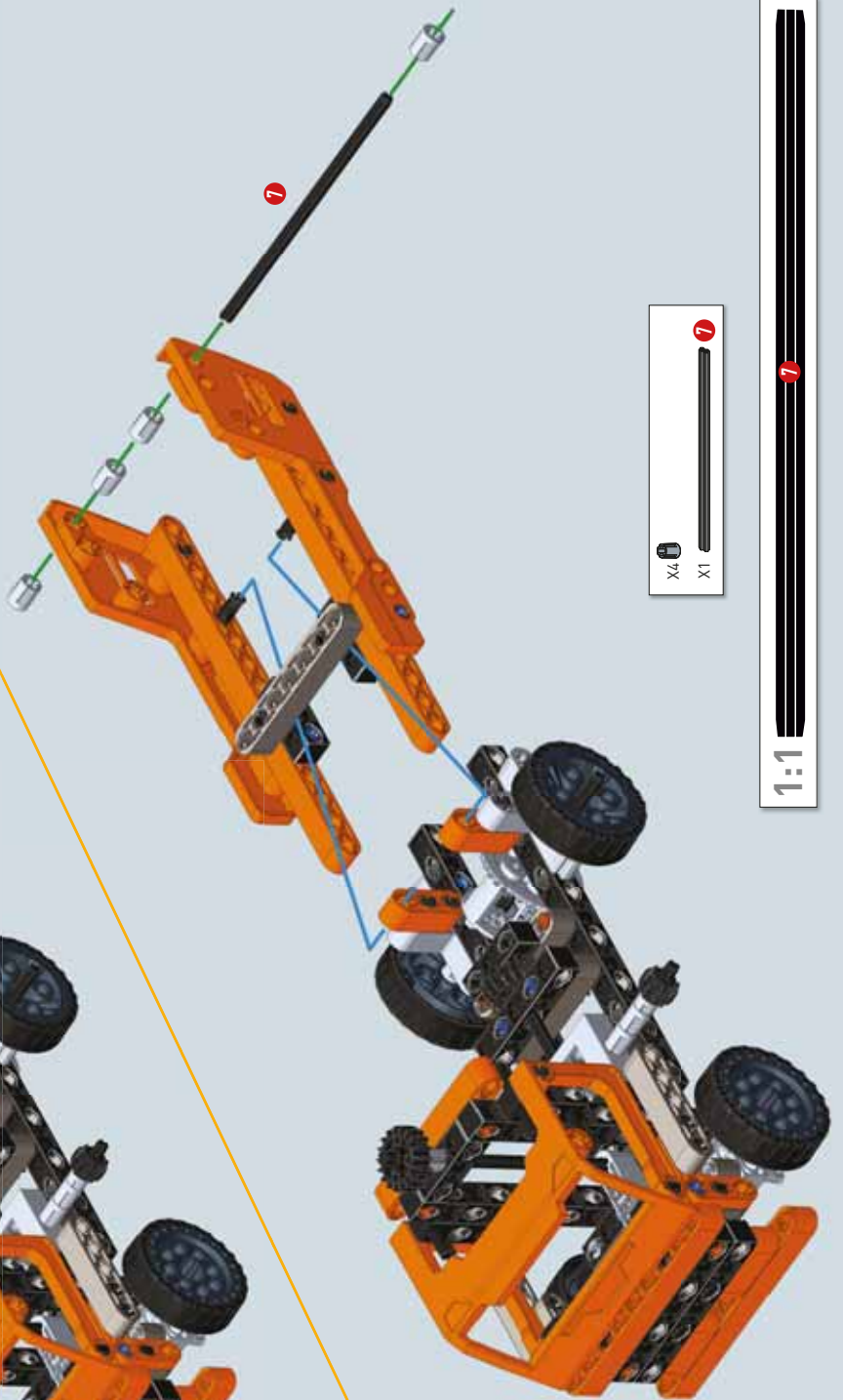
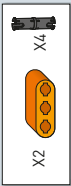
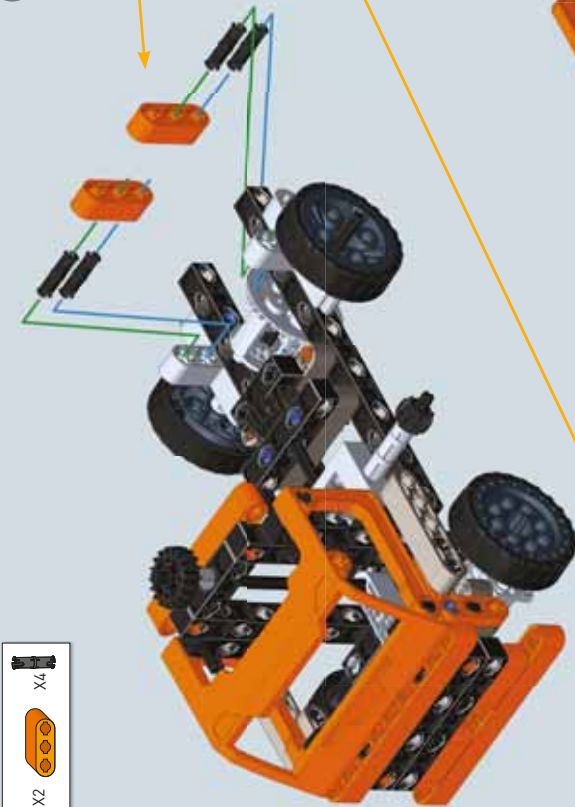

4



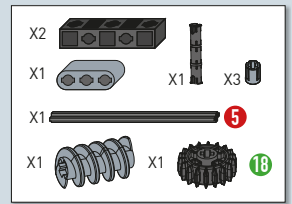

5

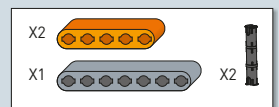
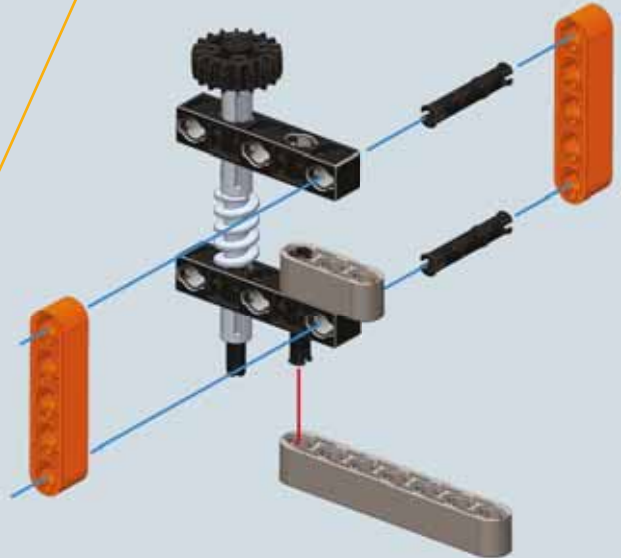

6

7

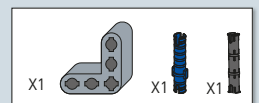

11

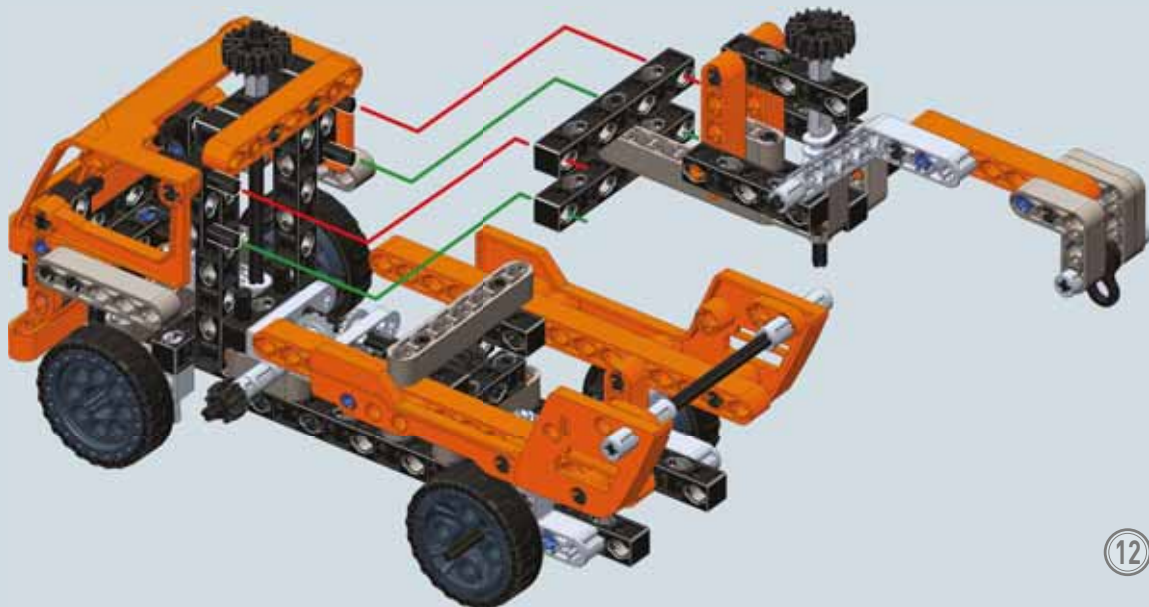
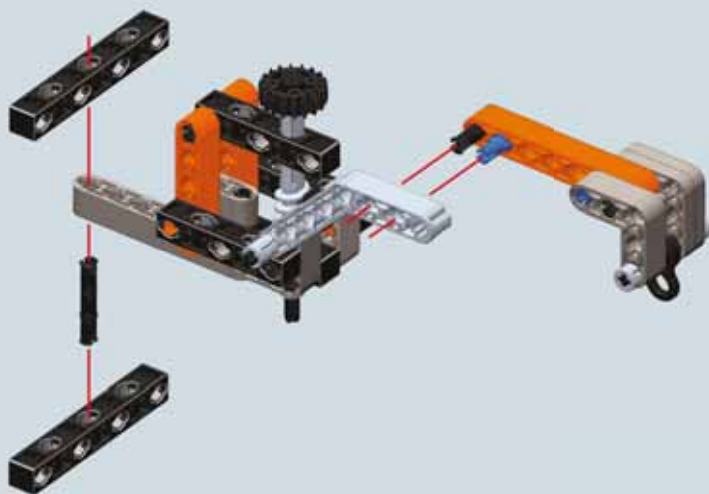
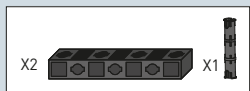

12



Modelo final





Notas técnicas y curiosidades

Con el término quitanieves no se alude a un vehículo sino a un sistema acoplado que se junta a un vehículo y se utiliza para quitar la nieve y el hielo de la vía. El quitanieves consiste en una placa de acero perfilada que se puede instalar no solo en un camión sino también en vehículos todoterreno comunes, o incluso en trenes, para despejar las vías.

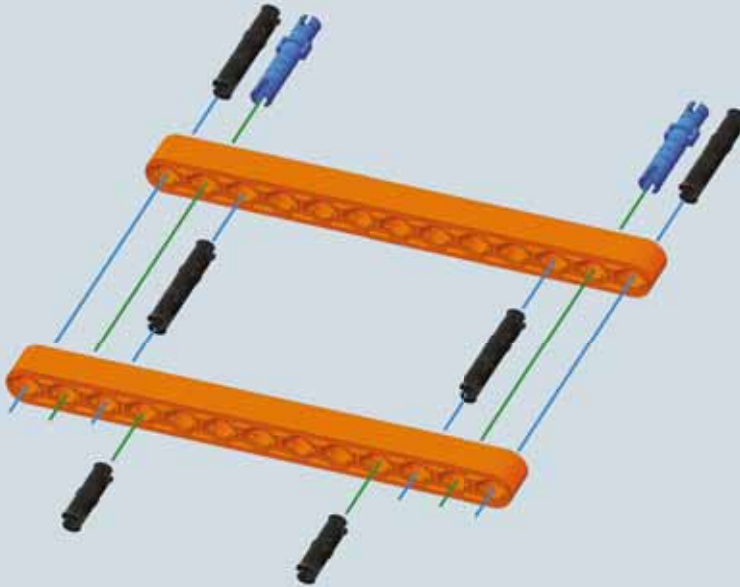

1

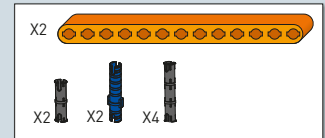

2

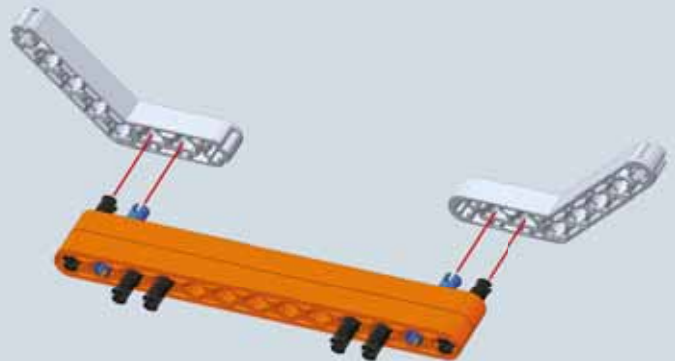
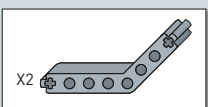

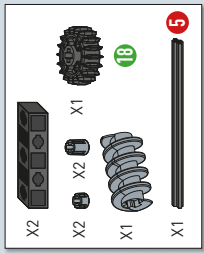

4

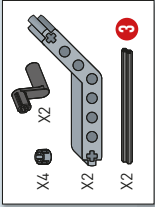

3

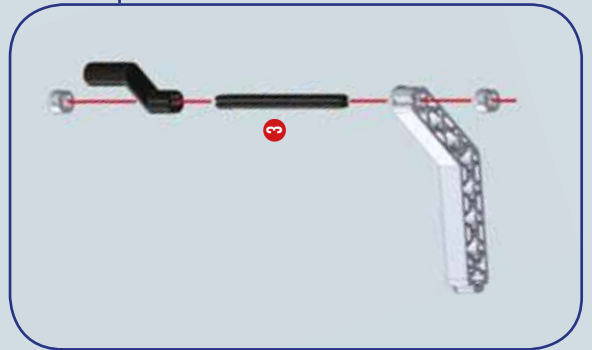
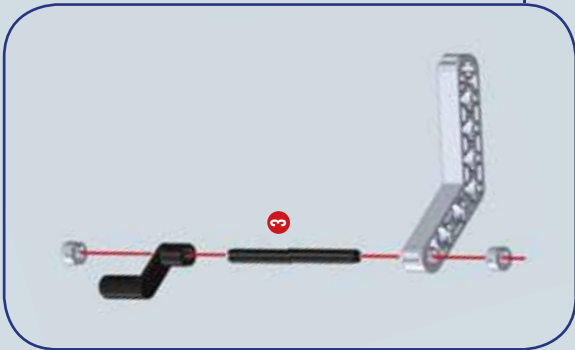
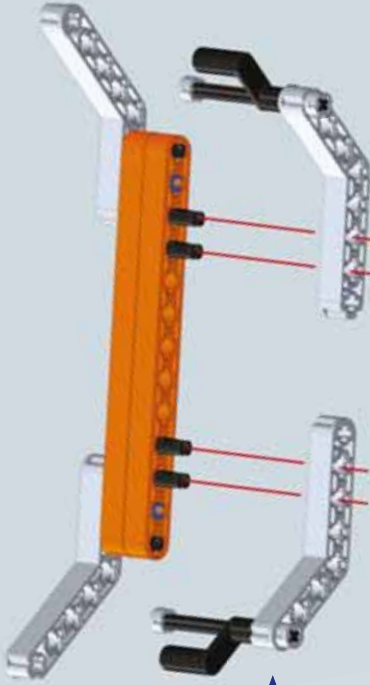

5

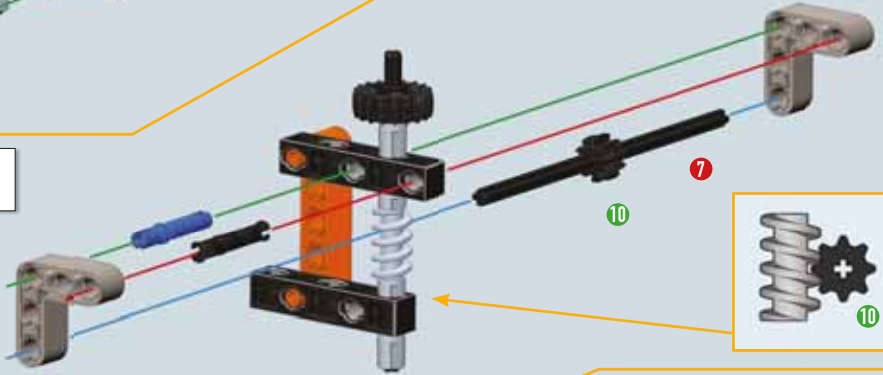
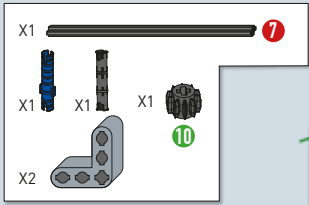
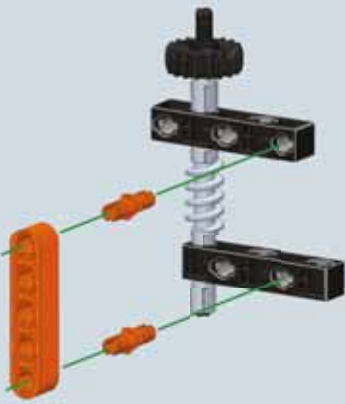
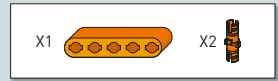

6

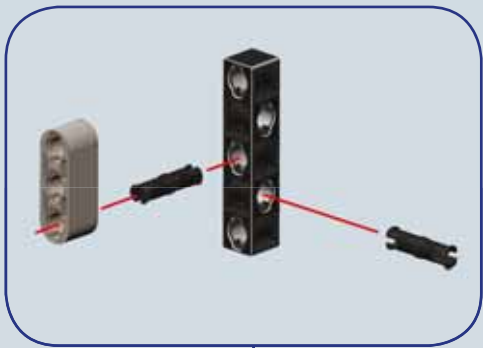

7

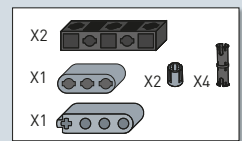
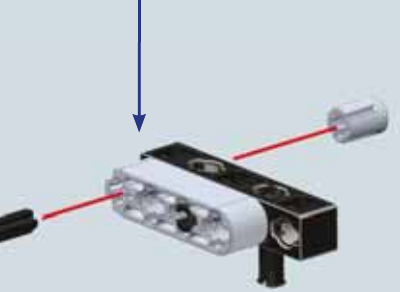
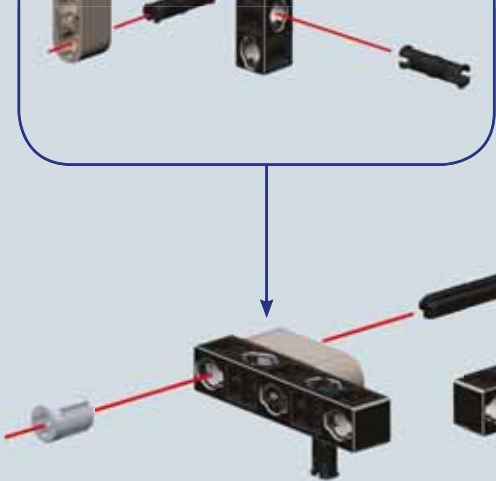

9

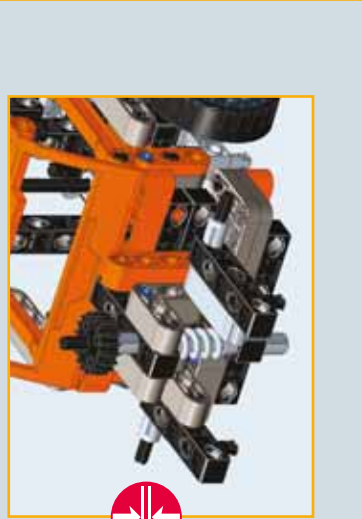
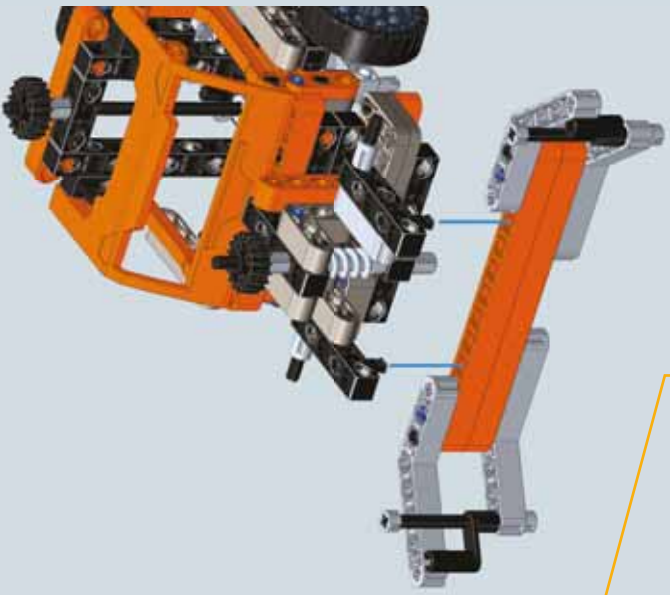

8

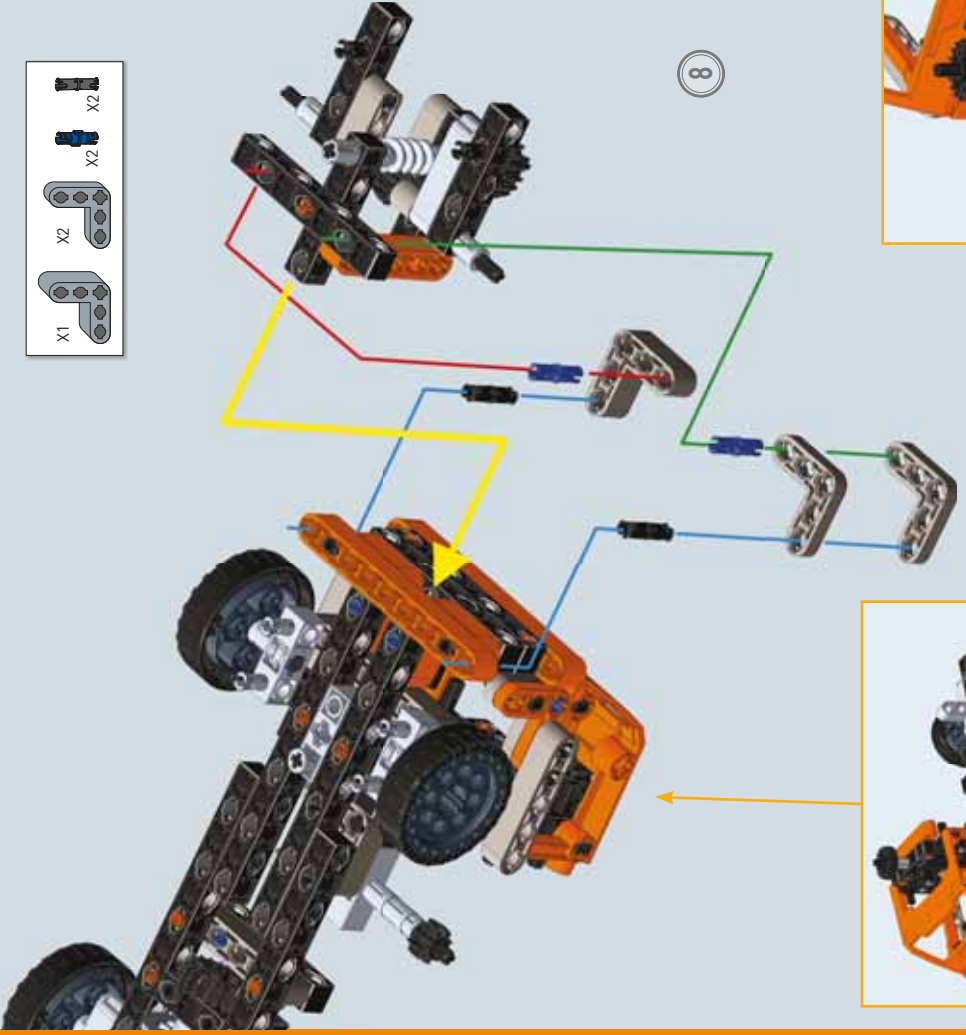
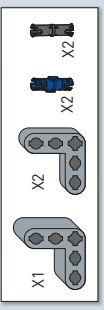

Modelo ensamblado en la tarea 4

10

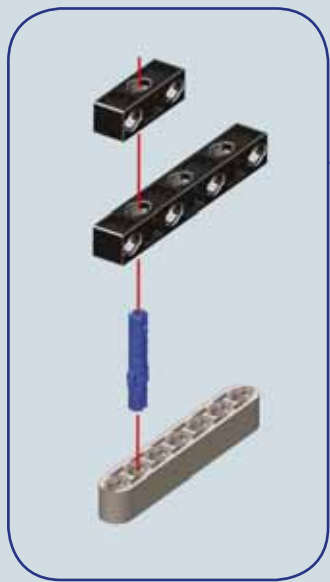
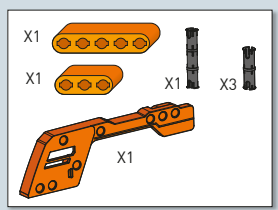

11

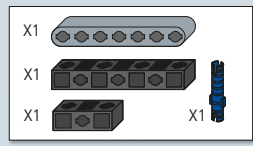
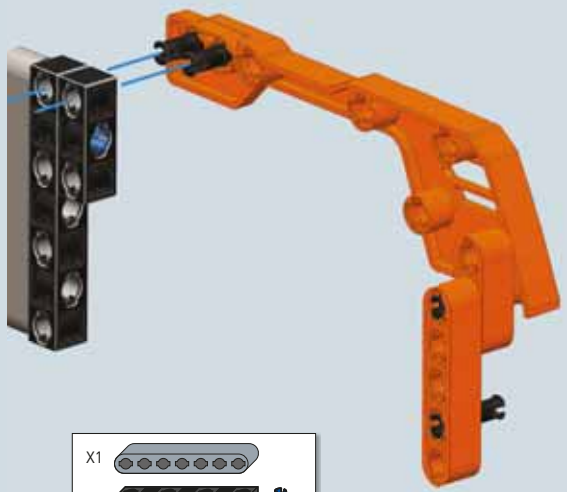

12

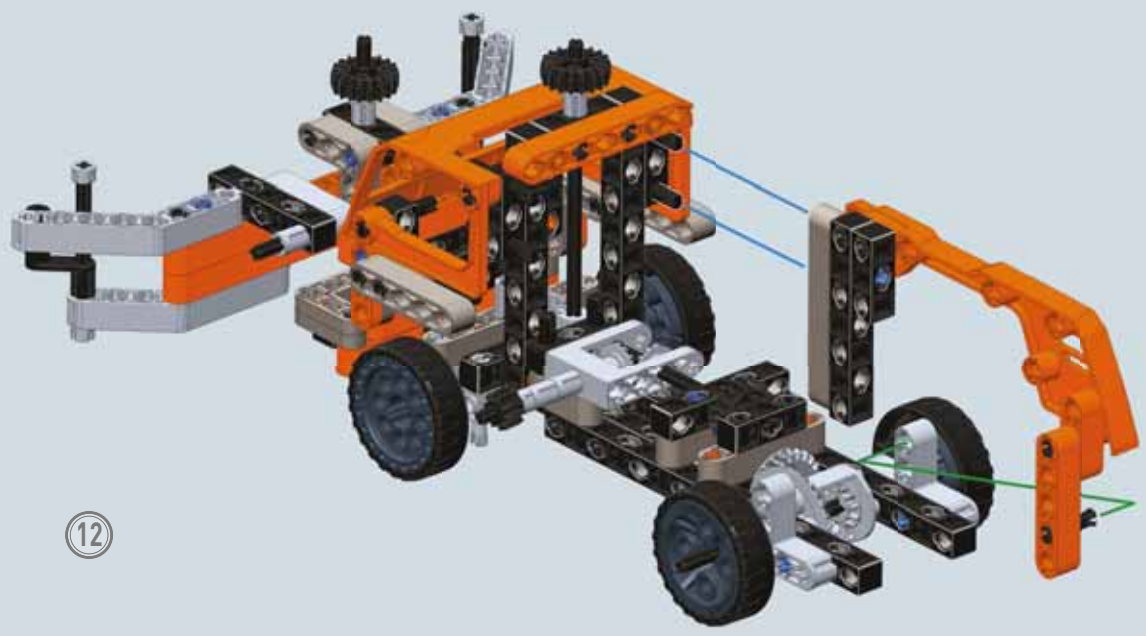

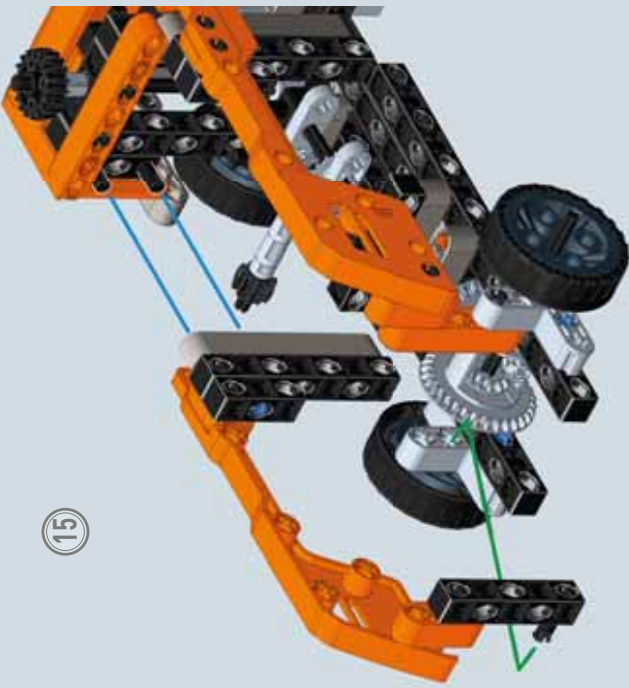

15

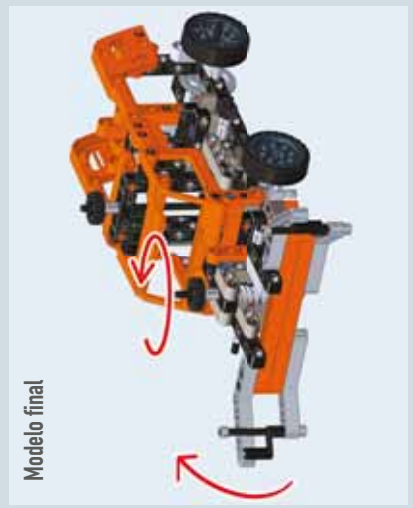

Modelo final

14

13

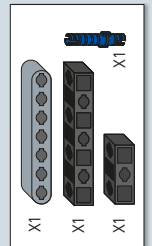
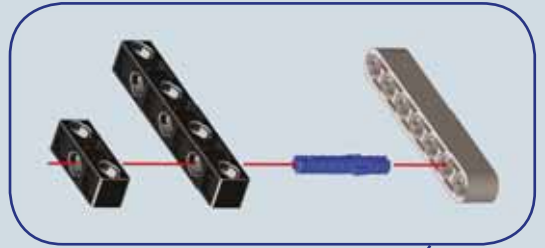
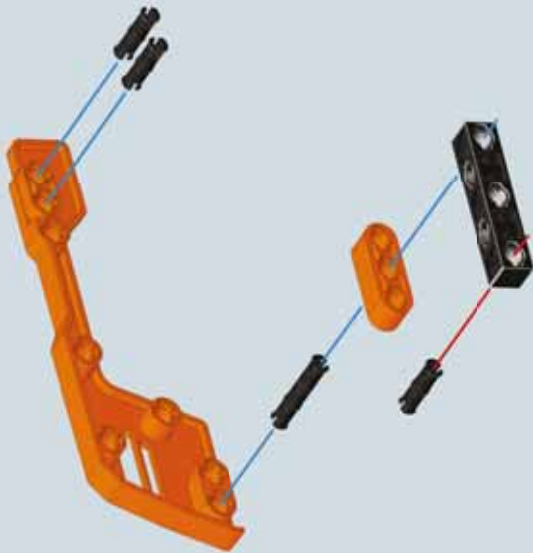
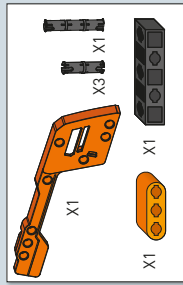



Notas técnicas y curiosidades

Una característica que permite reconocer al instante los camiones americanos es el morro alargado. En vista de que no están sujetos a las normas de seguridad vial de los países europeos y considerando los largos viajes que deben afrontar, estos modelos son auténticas casas rodantes.

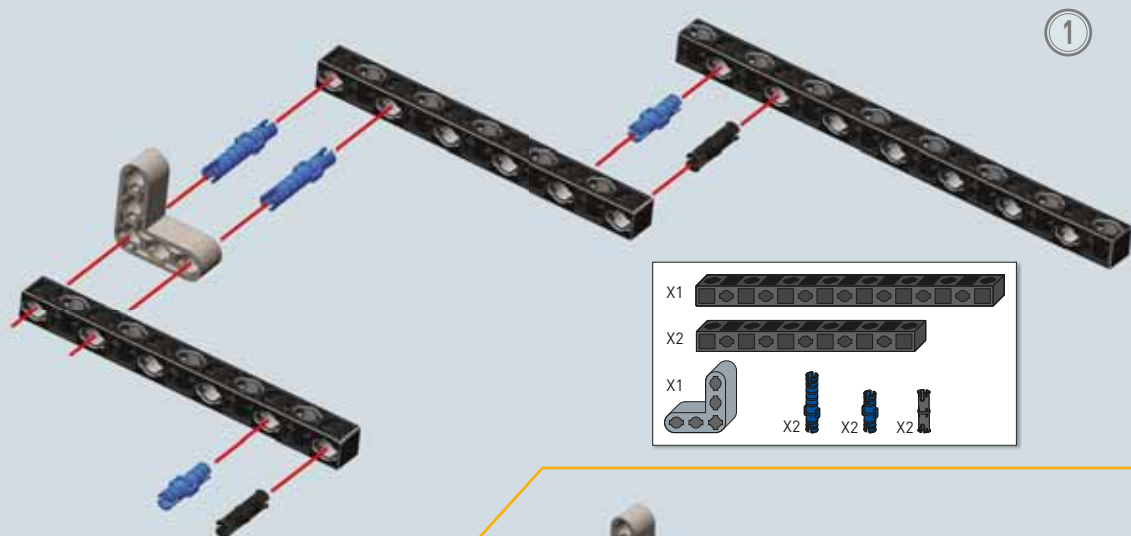

1

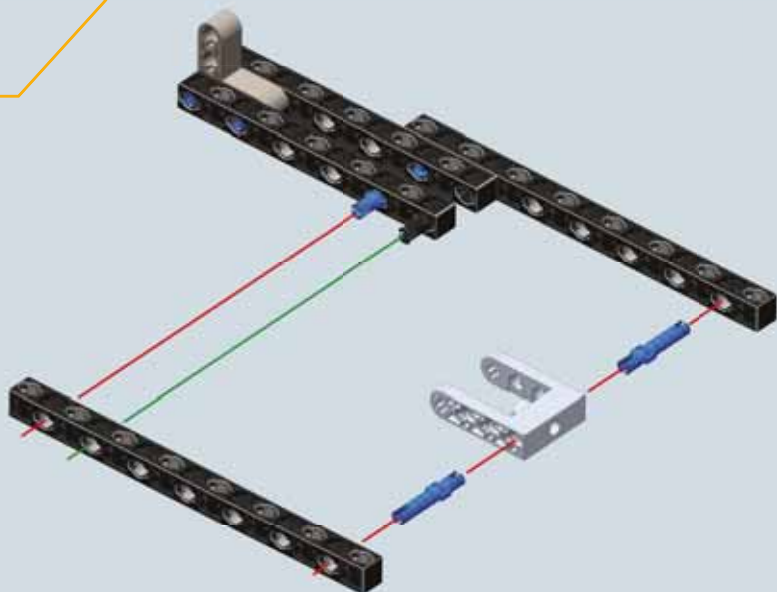
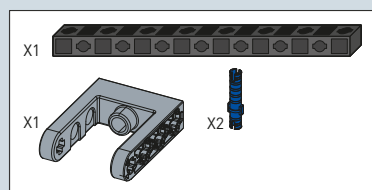
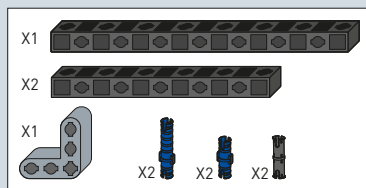

2

3

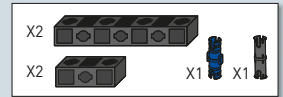
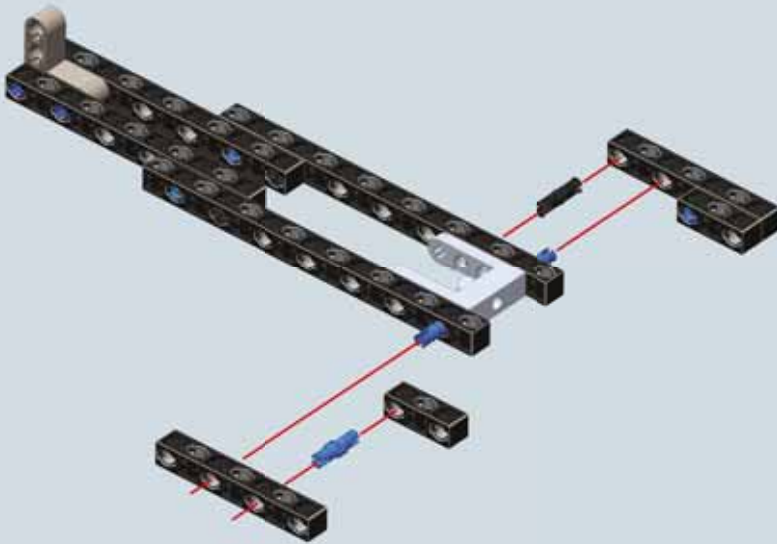

4

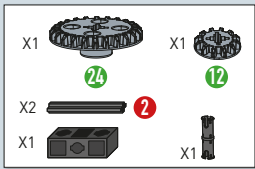
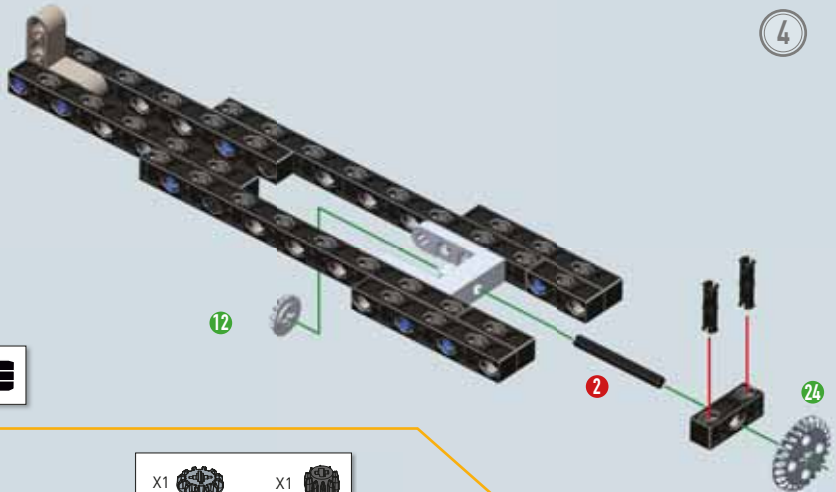

5

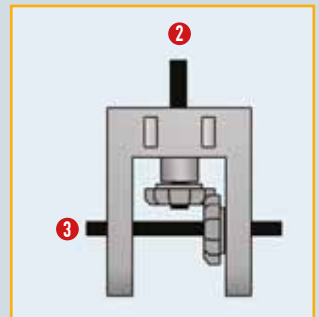
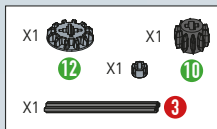
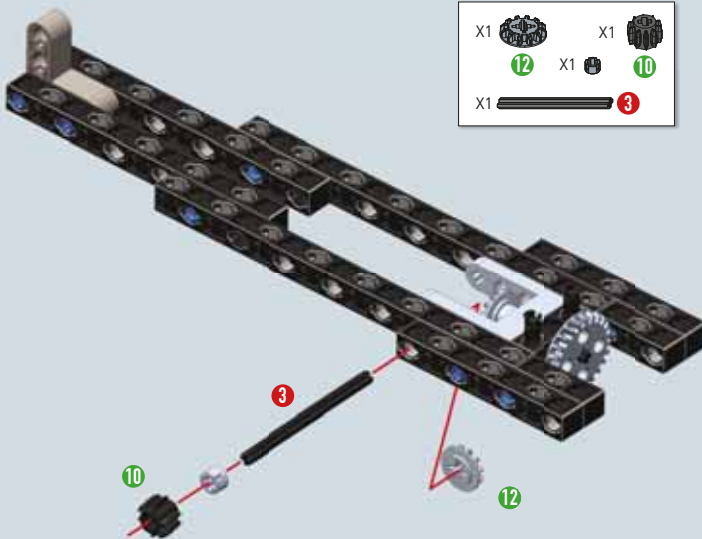

6

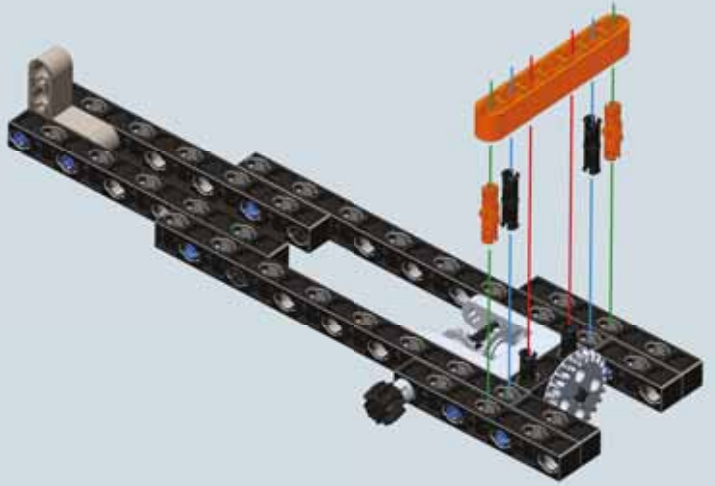

- X1
- X2
- X2

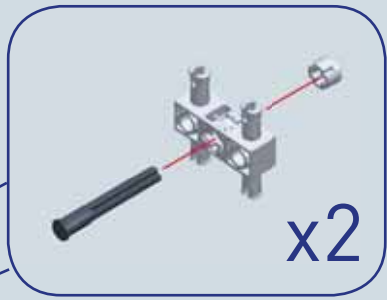
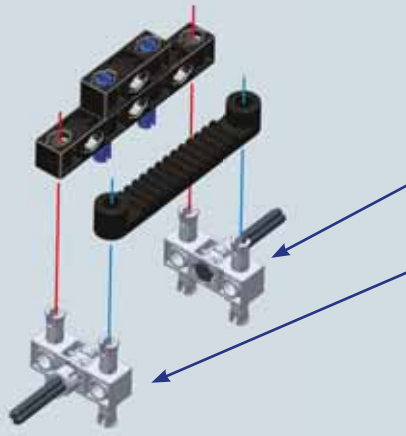
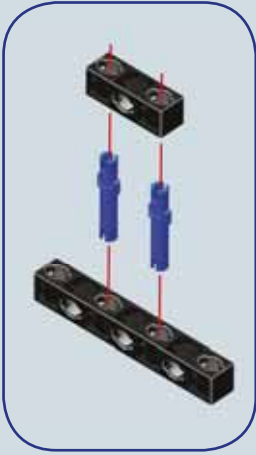

7

- X2
- X1
- X1
- X1
- X2
- X2
- X2
- X2
- X1

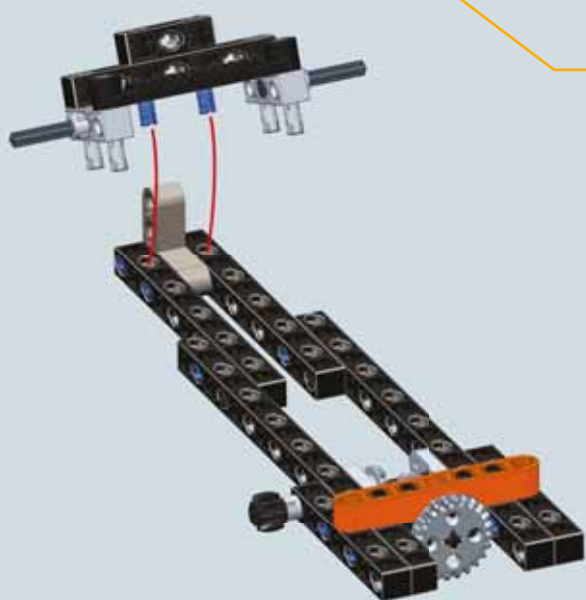

8

9

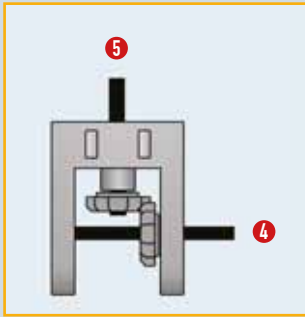
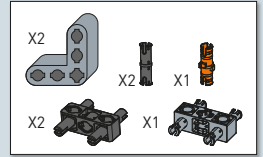
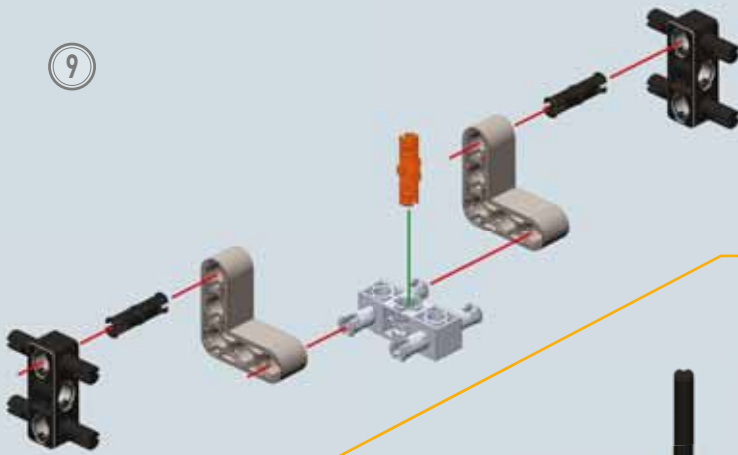

10

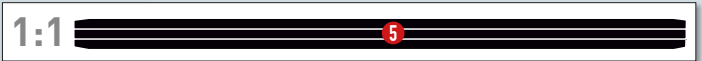
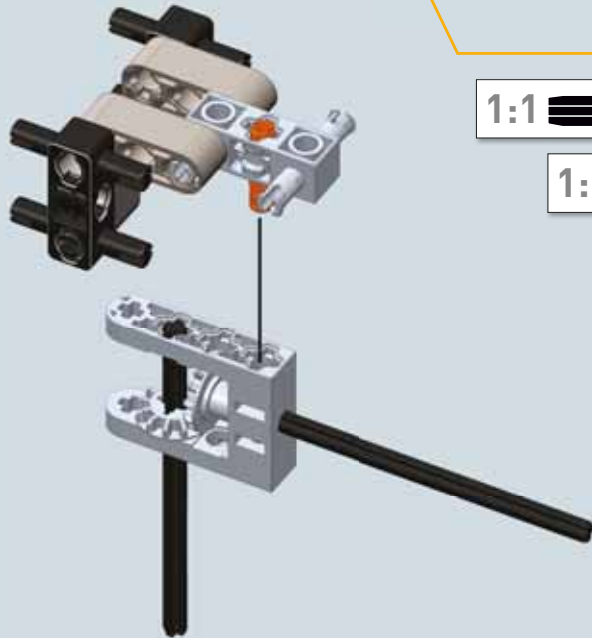
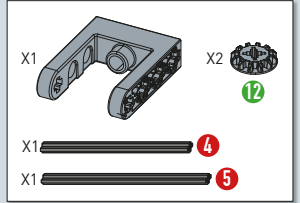
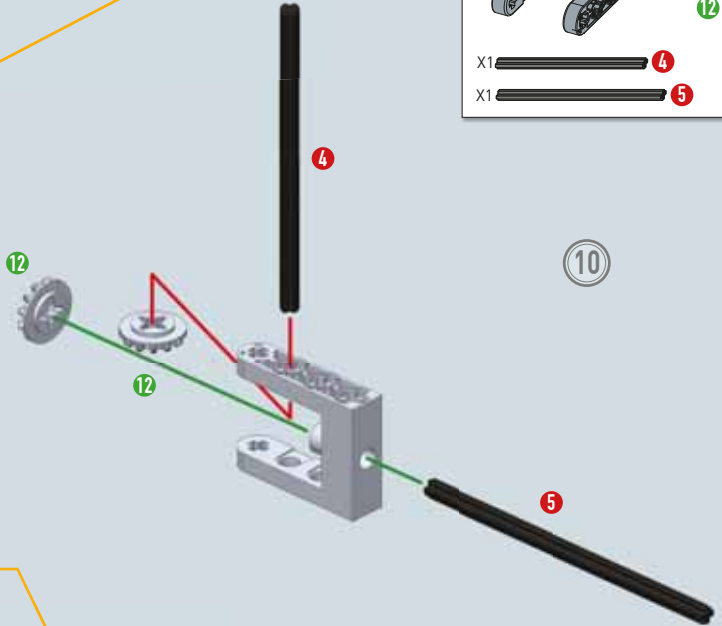

11

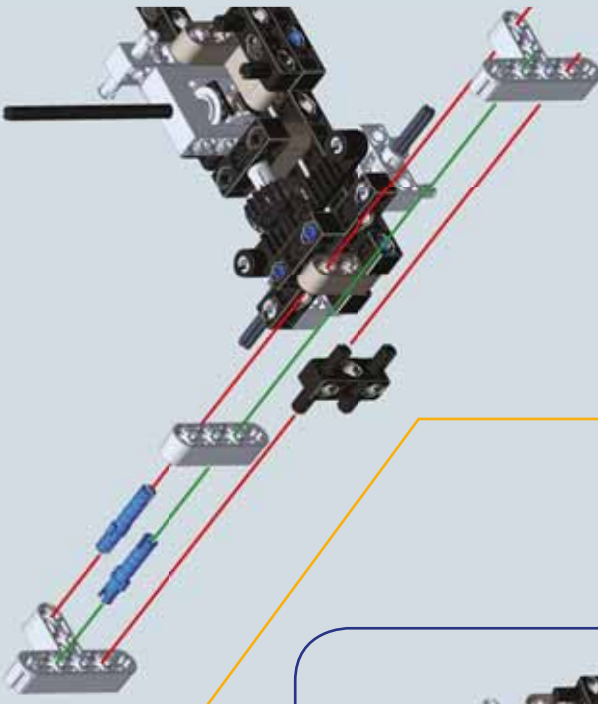

13

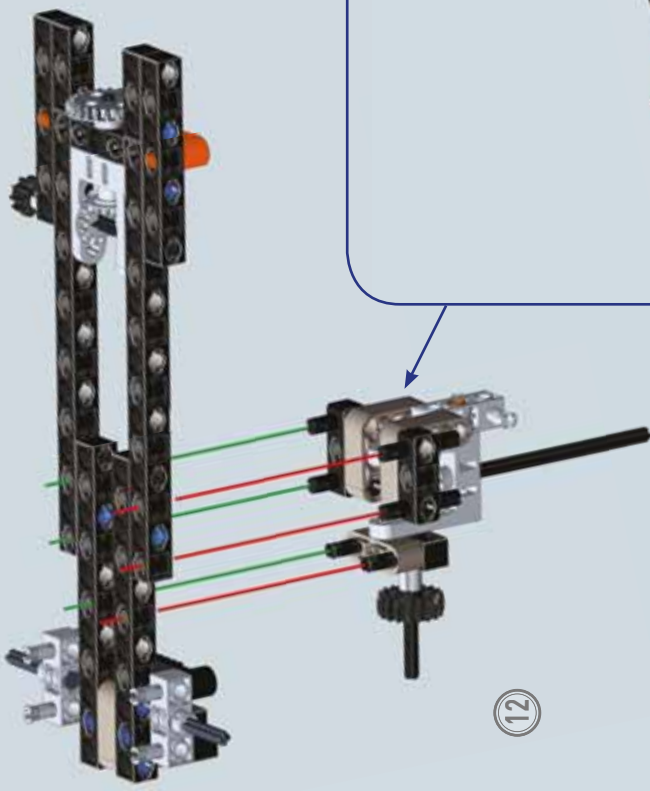
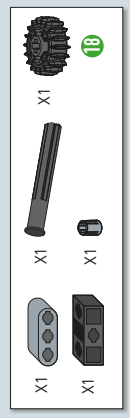
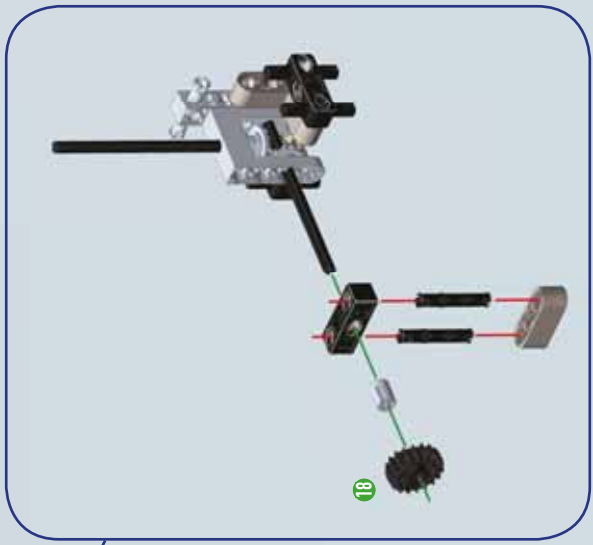
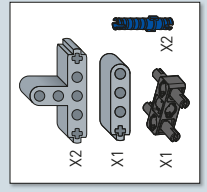

12

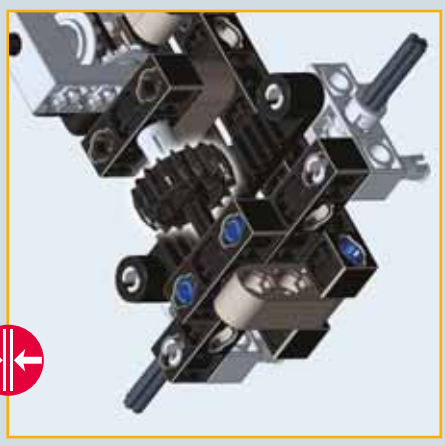

14

- X4
- X4
- X2
- X4
- X4
- X4
- X4
- X2
- X2

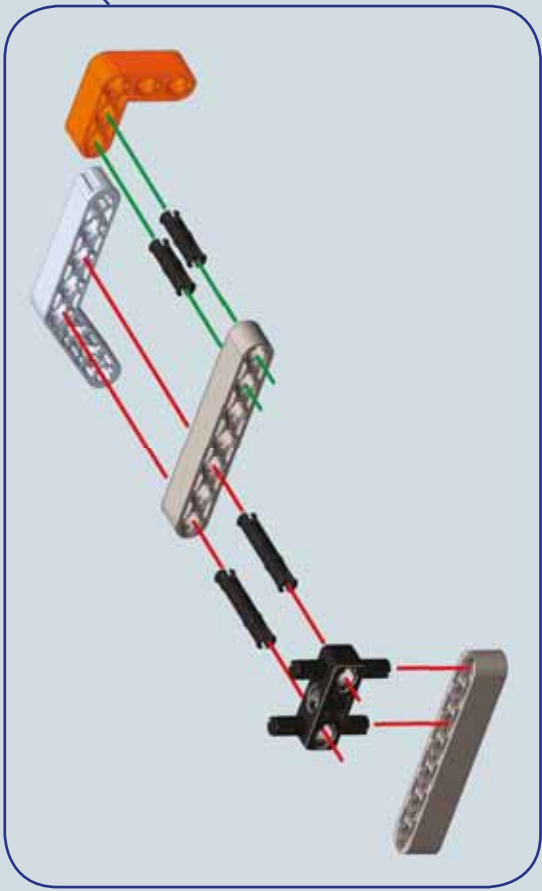
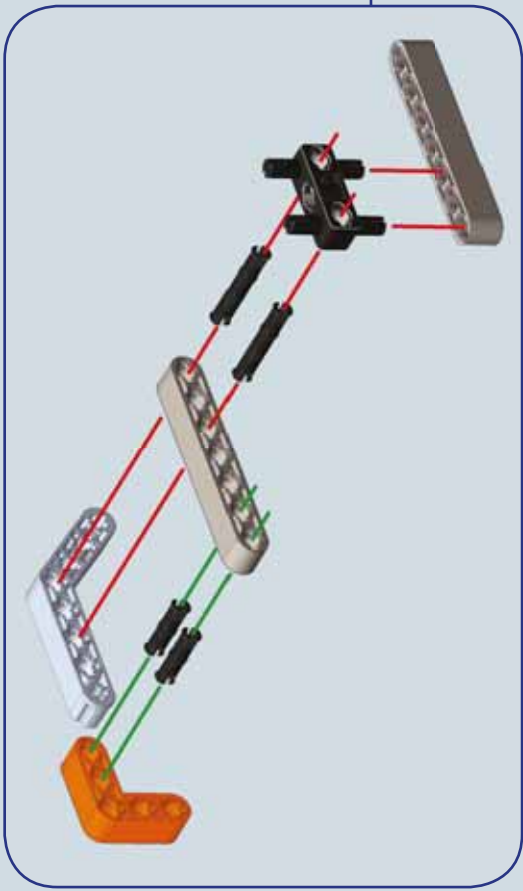
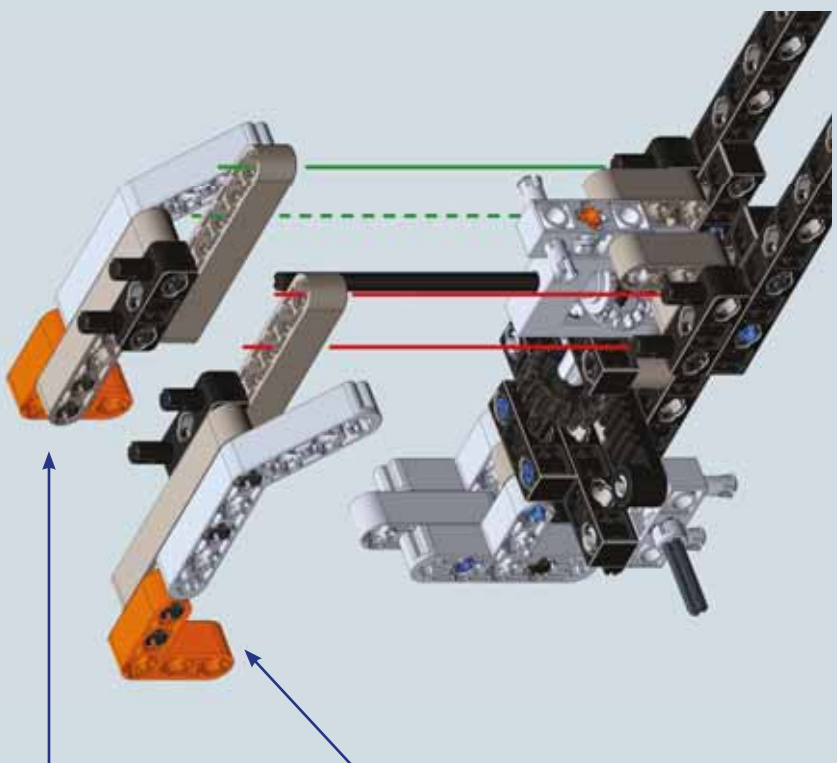

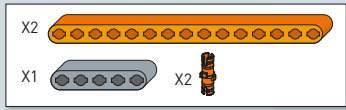

15

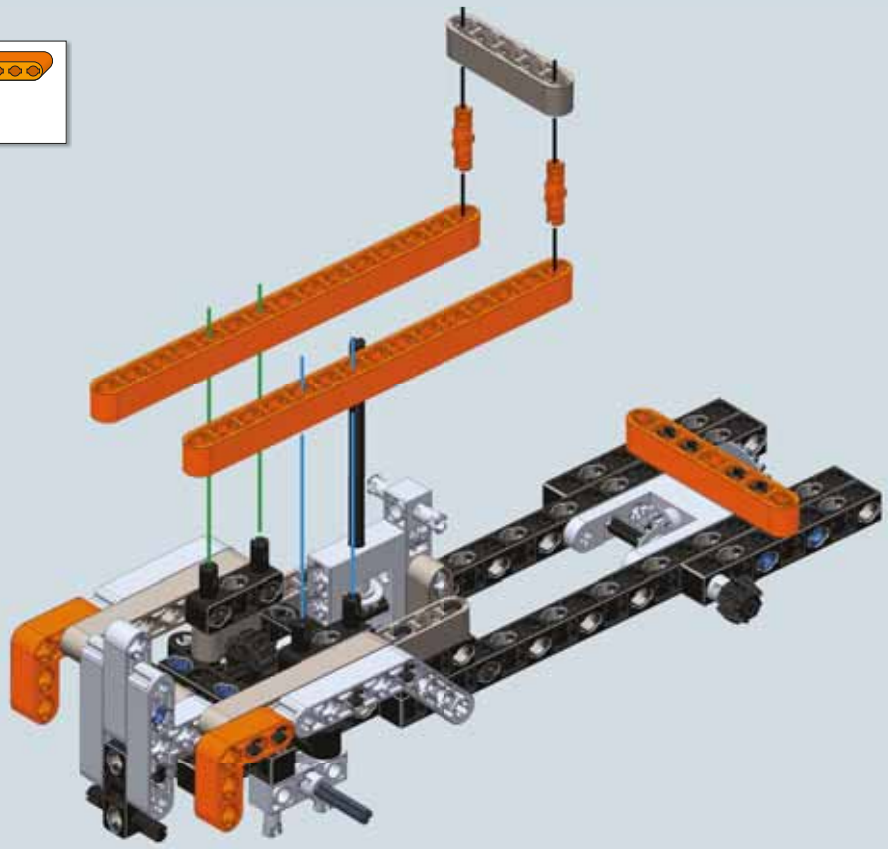

16

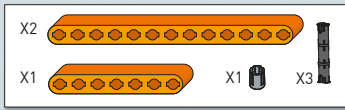
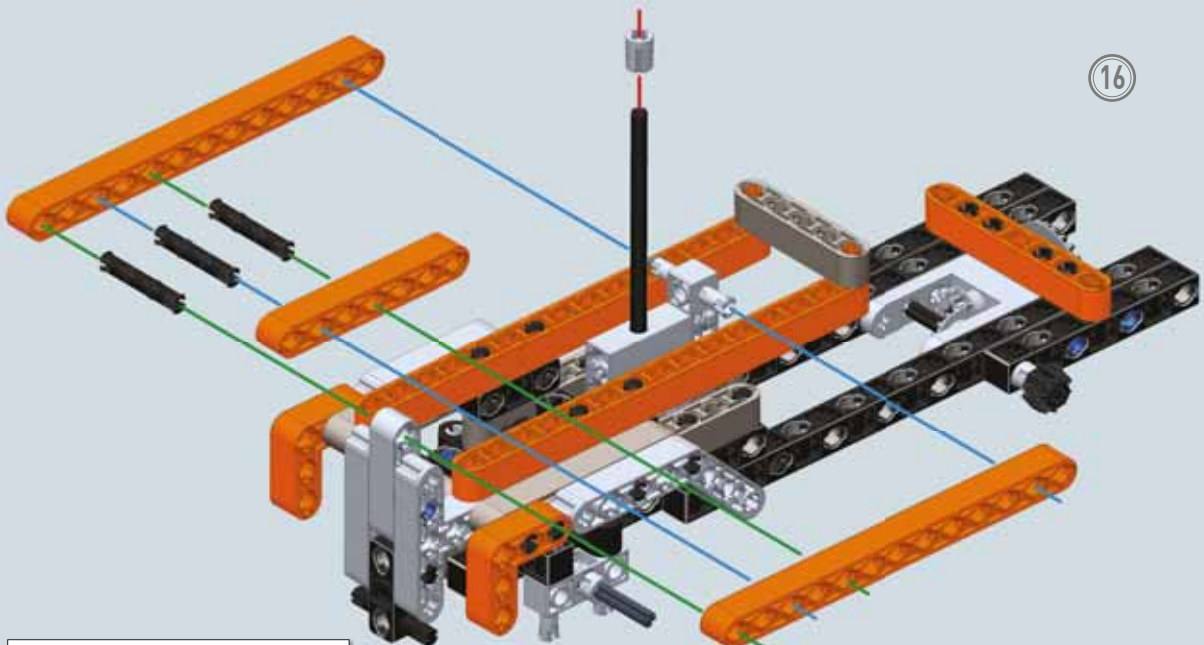



17

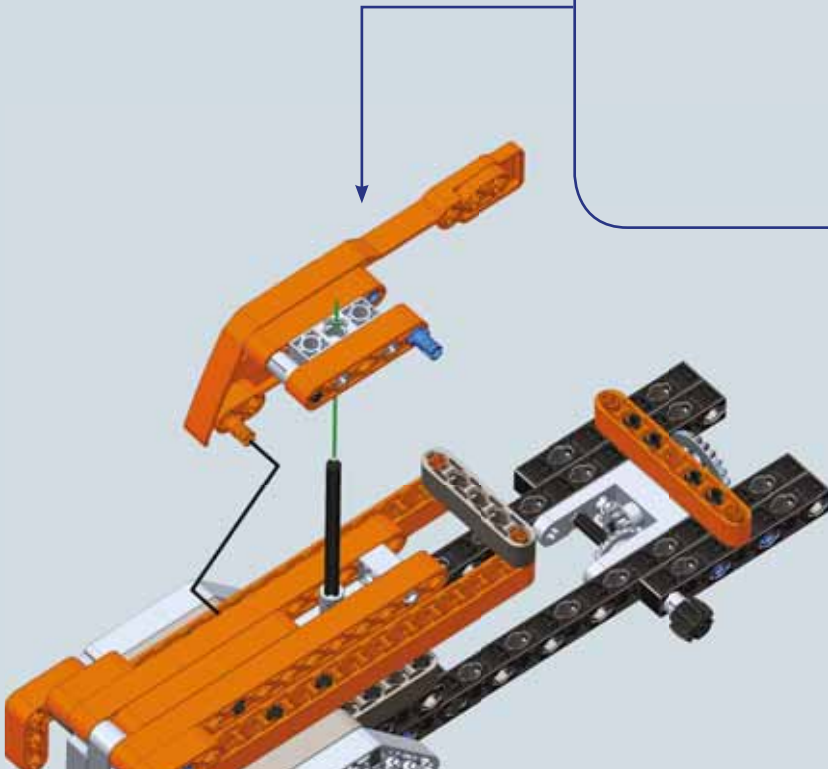
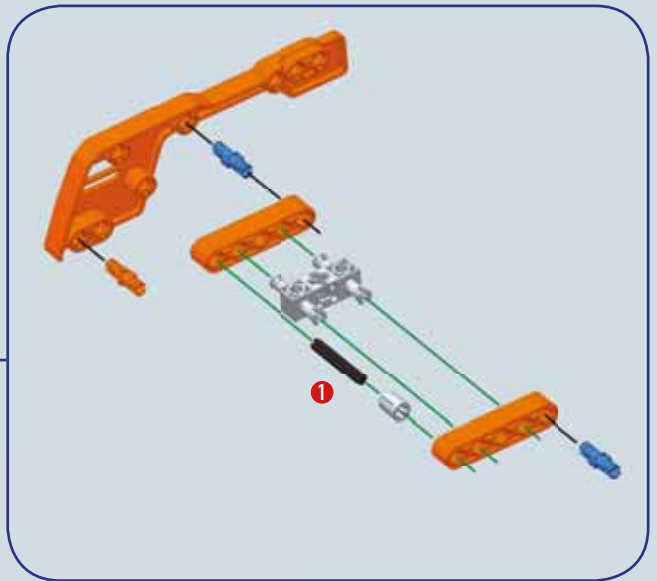
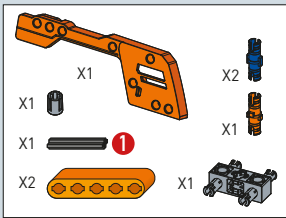

18



19

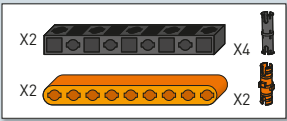
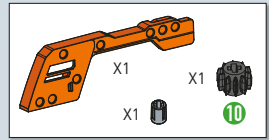
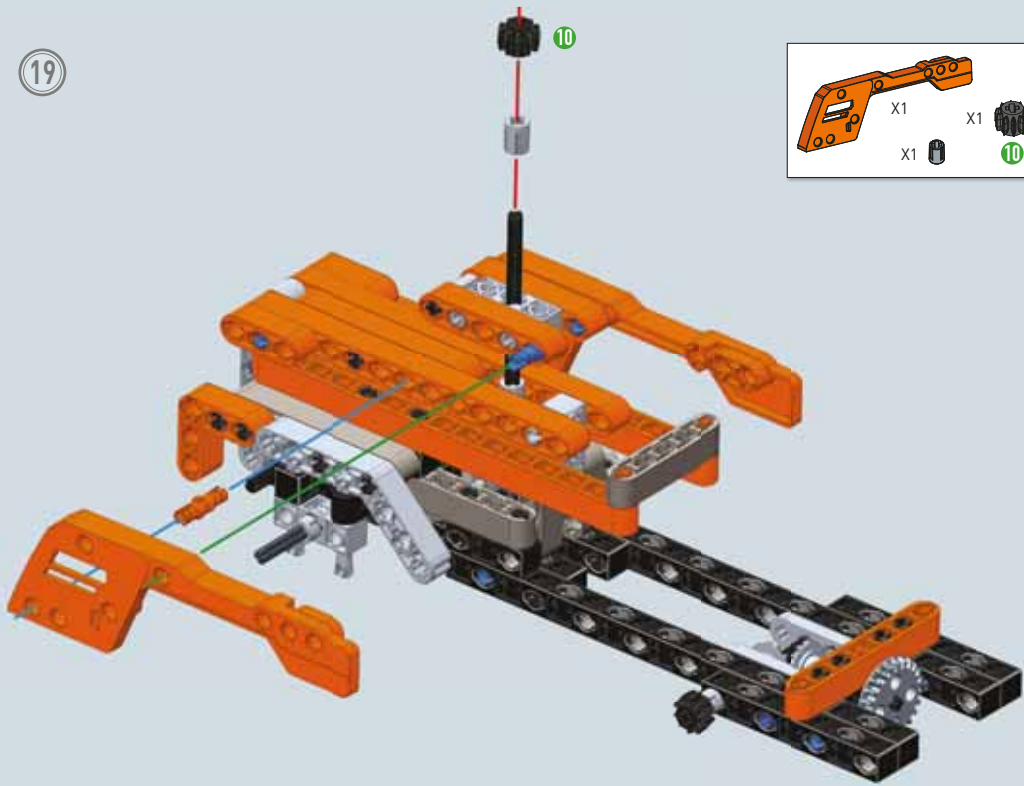

20

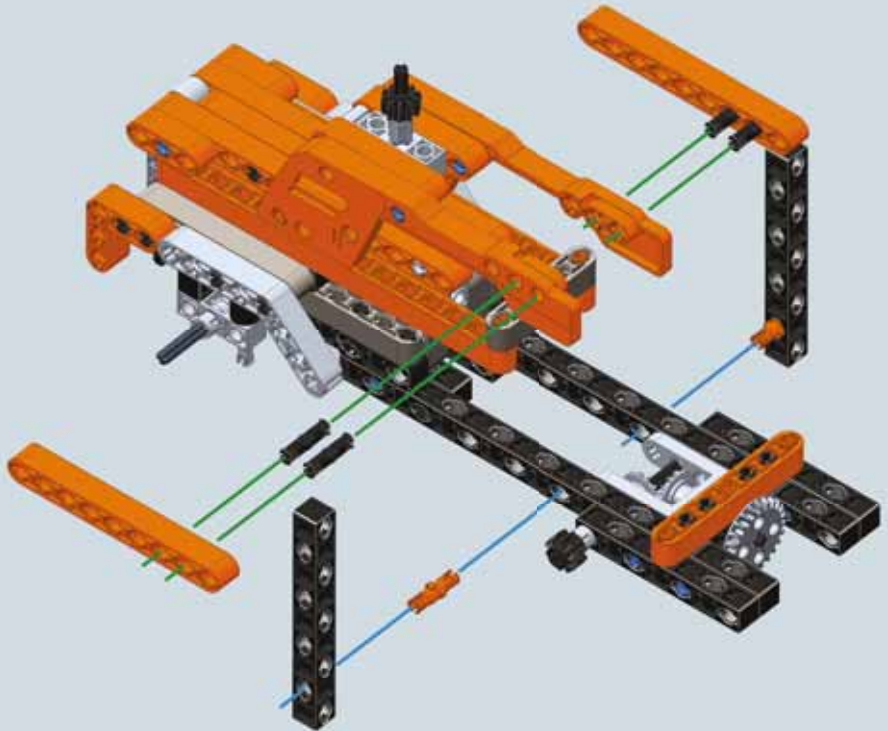

21

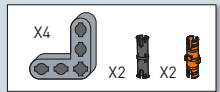
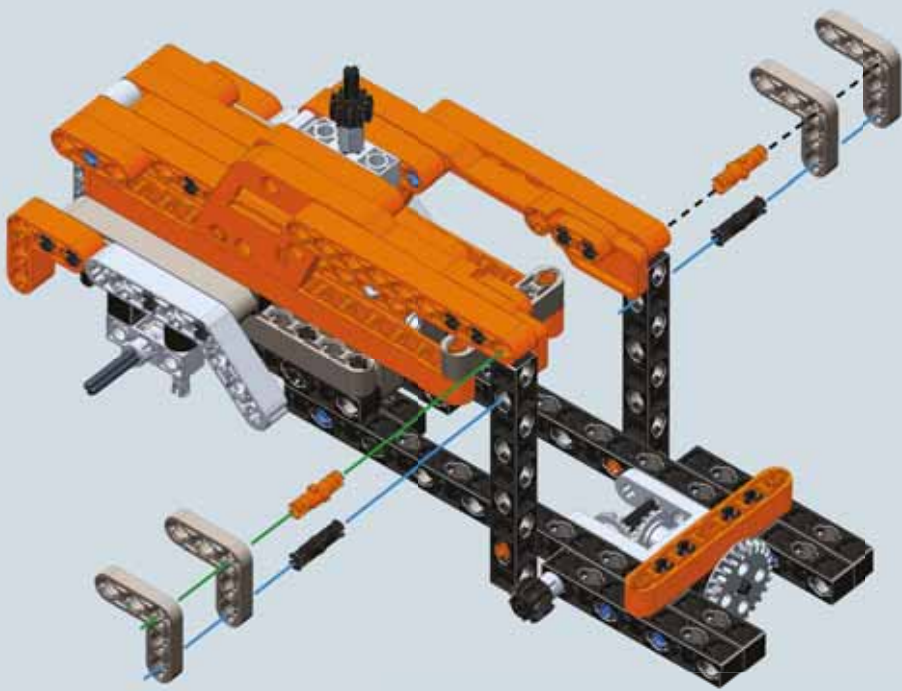

22

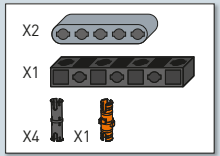
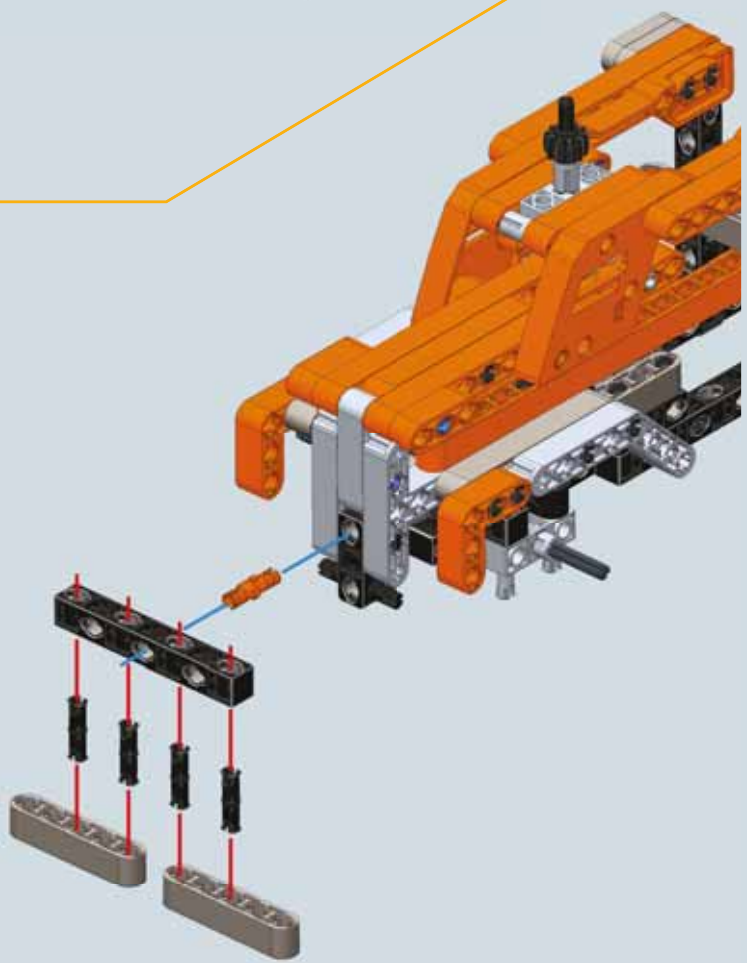

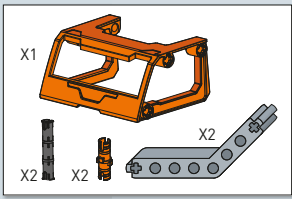

23

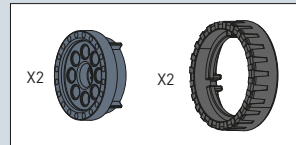
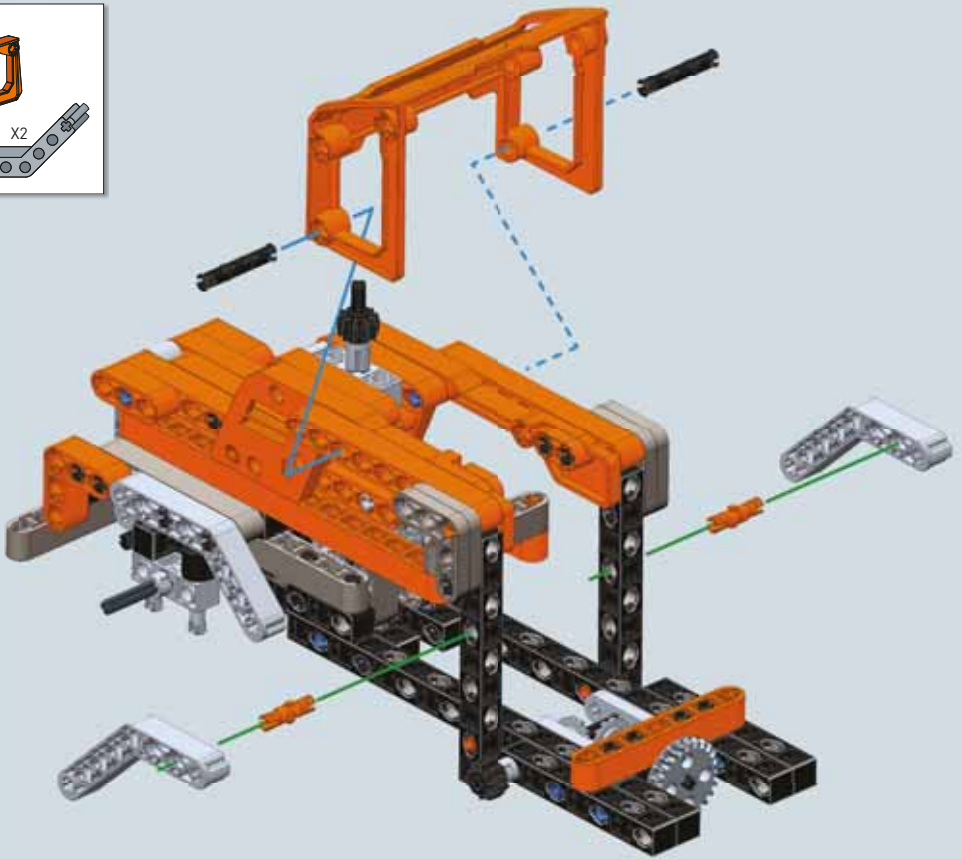

24

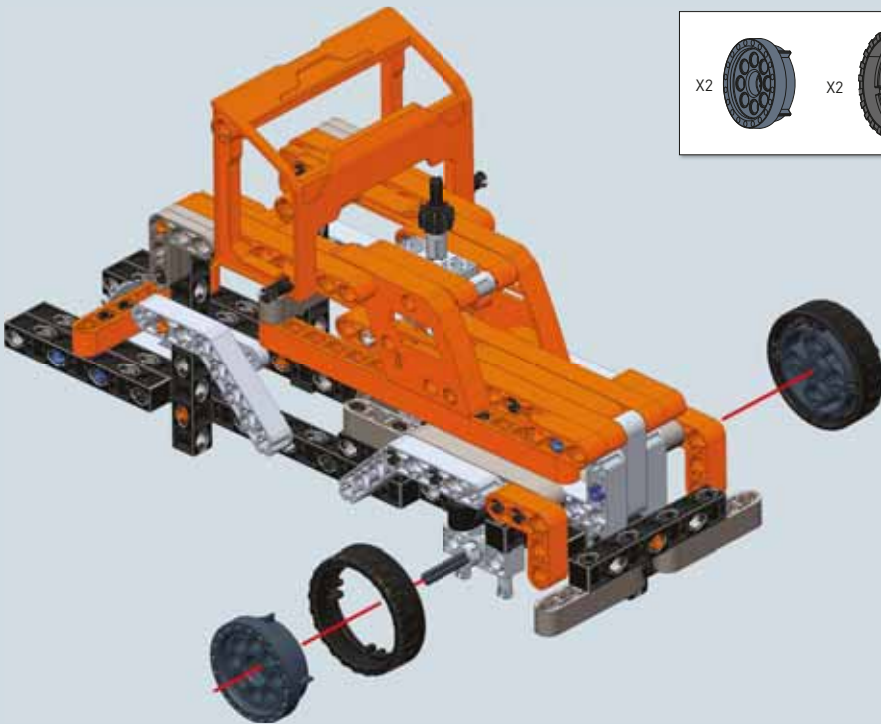

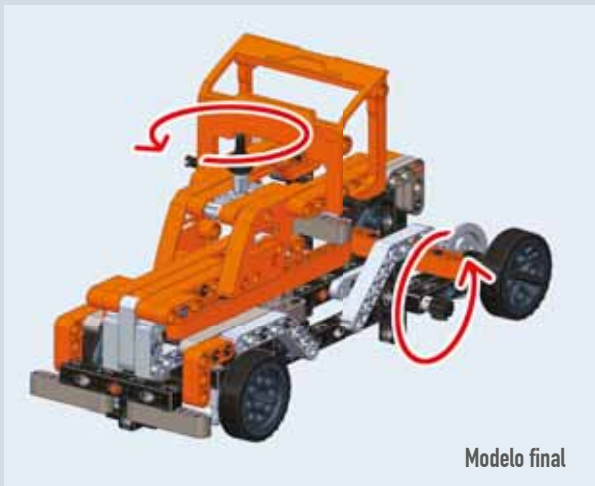
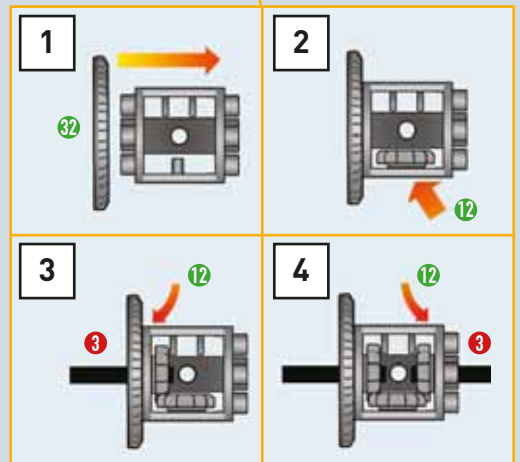
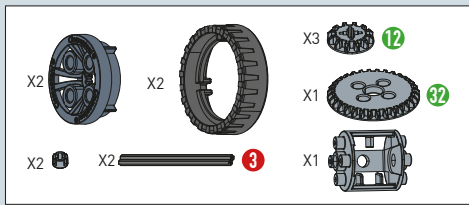
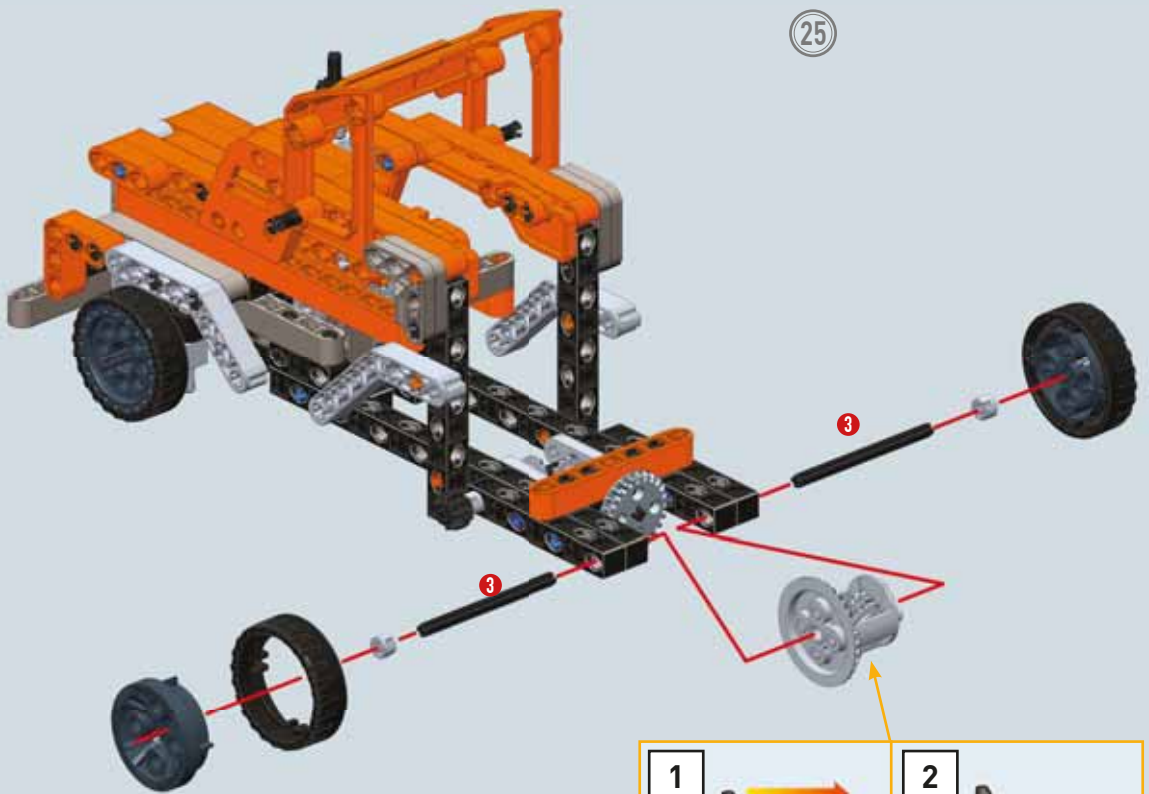

Modelo final

