

2

Naukowa Zabawa

TECHNOLOGIC

Laboratorium MECHANIKI

MASZYNY ROLNICZE

Konstrukcje od **7** do **10**

- 7 - Ładowarka czotowa
- 8 - Wiertnica glebowa
- 9 - Kultywator
- 10 - Żniwiarka

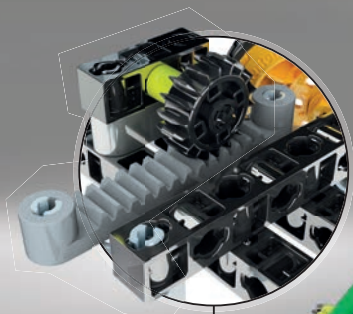

V3.6950

Producent: Clementoni S.p.A.
Zona Industriale Fontenoce s.n.c.
62019 Recanati (MC) - Italy
Tel. : +39 071 75811
www.clementoni.com

Clementoni Polska Sp. z o.o.
ul. Budowlanych 27, 80-298 Gdańsk, Polska - poland@clementoni.com

Przeczytaj i zachowaj niniejszą instrukcję.



7 ŁADOWARKA CZOŁOWA

1

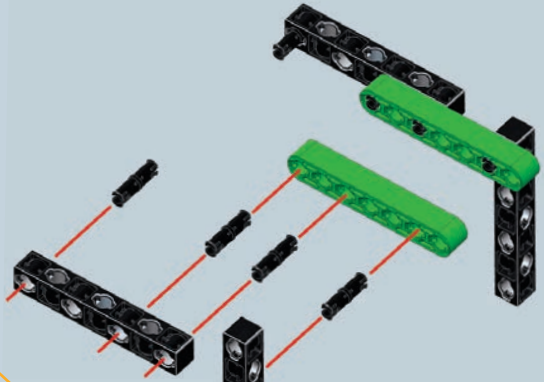
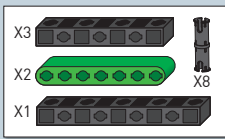

2

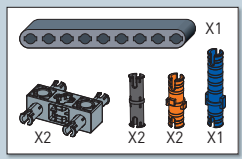
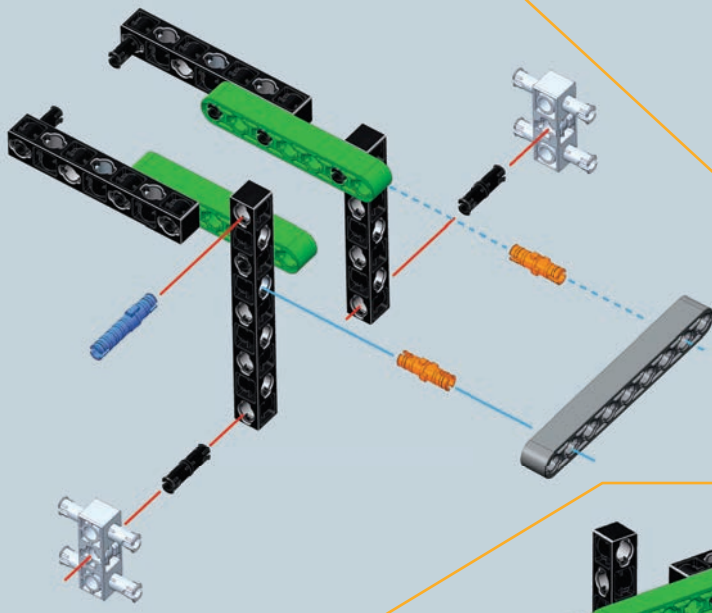

3

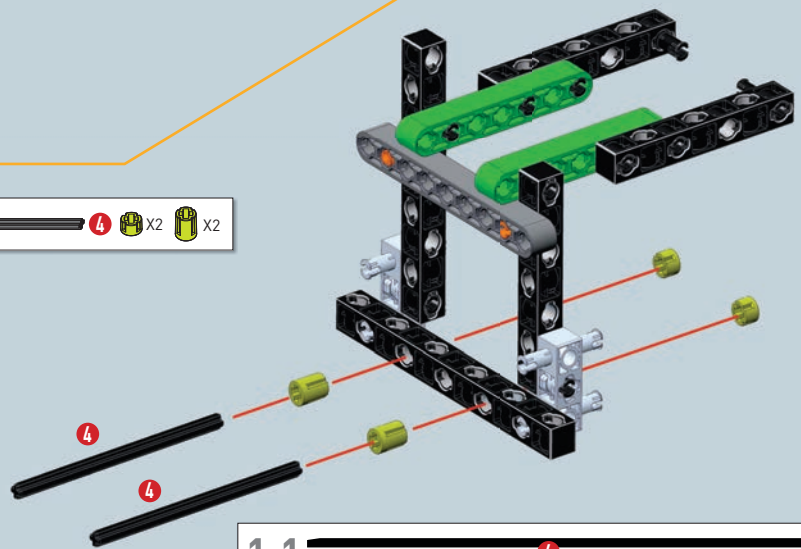



Model złożony w zadaniu 2

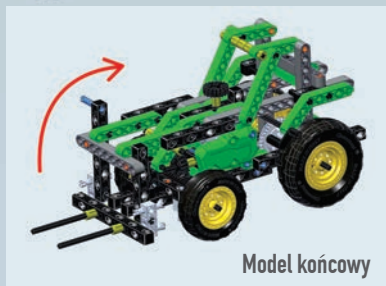
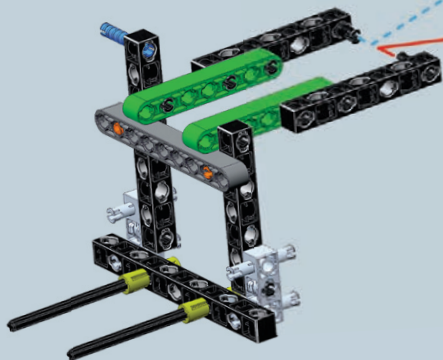

Model końcowy

8 WIERTNICA GLEBOWA

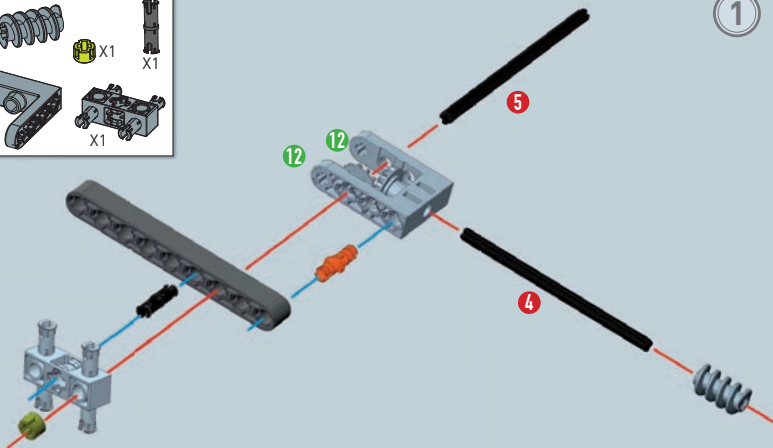
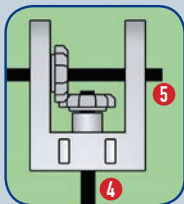
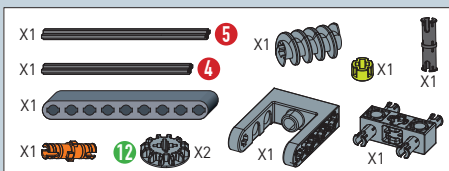

2

Aby złożyć przegub Cardana przestrzegaj instrukcji przytoczonych w ilustrowanej ulotce z ostrzeżeniami.

3

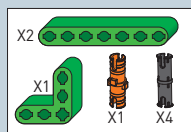
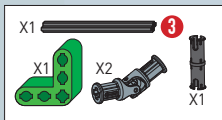
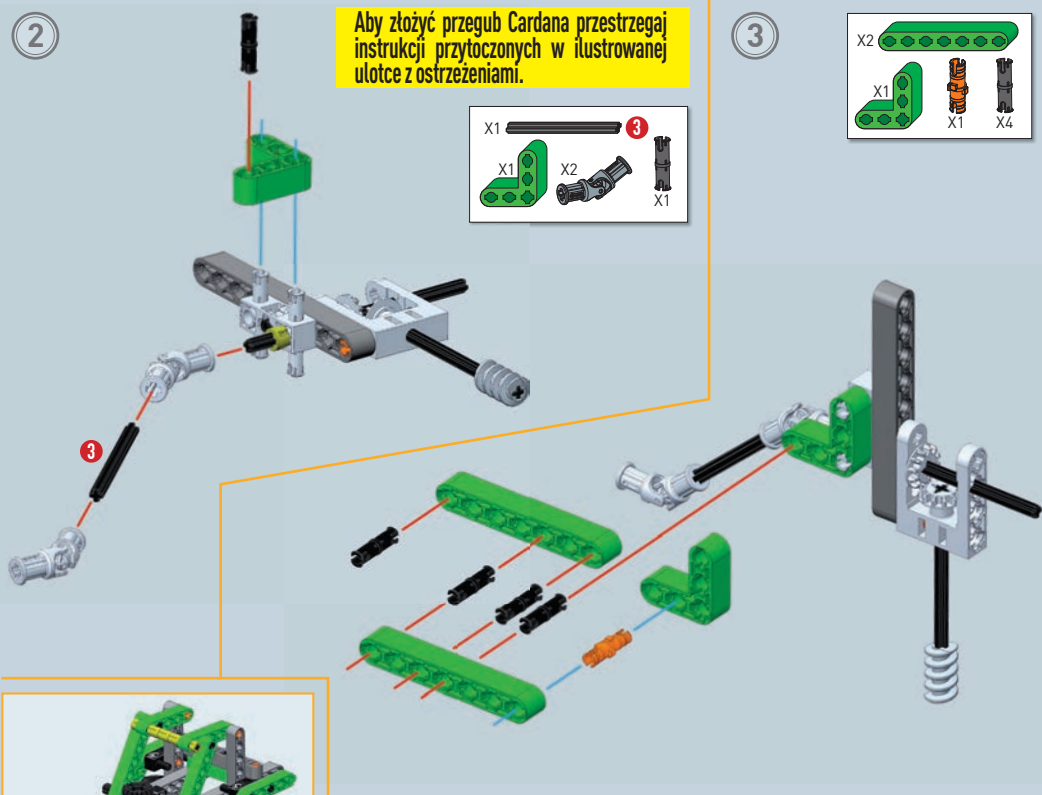

Model złożony w zadaniu 2

4

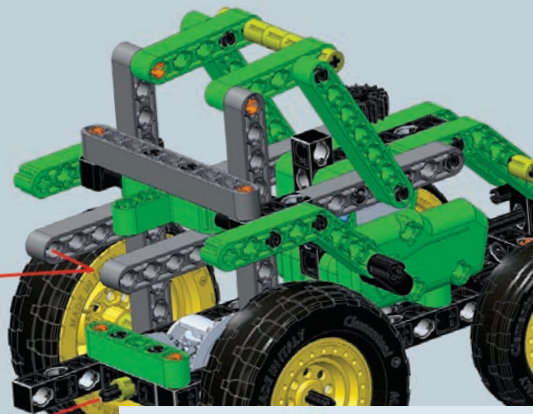
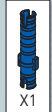

Model końcowy



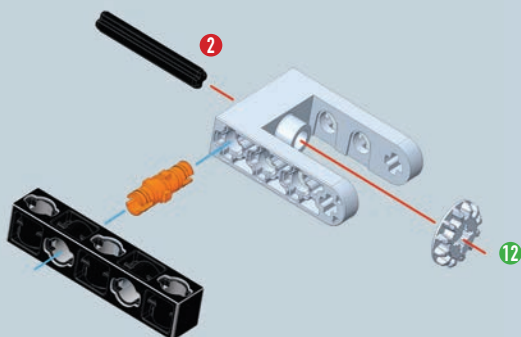
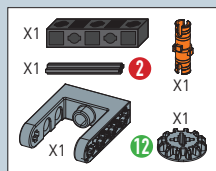

1

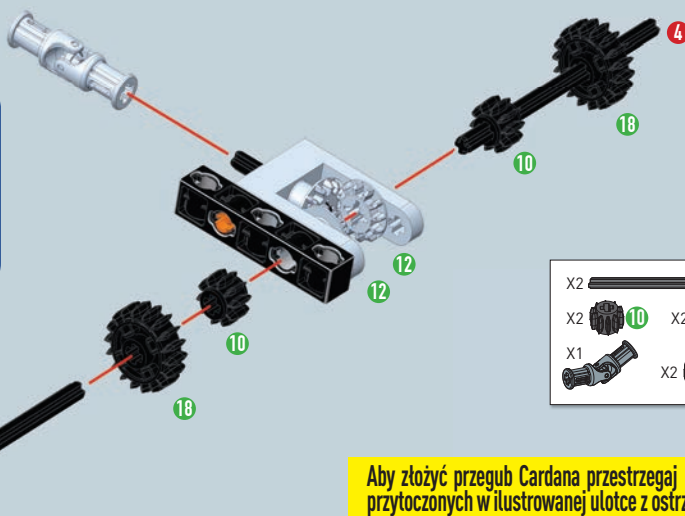
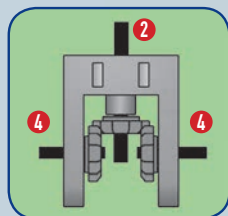

2

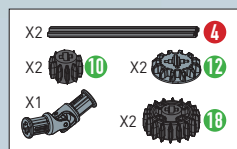

Aby złożyć przegub Cardana, przestrzegaj instrukcji przytoczonych w ilustrowanej ulotce z ostrzeżeniami.

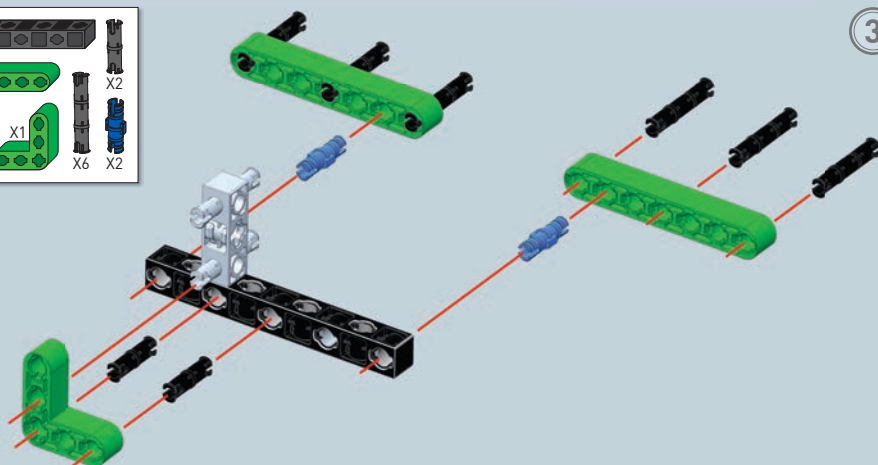
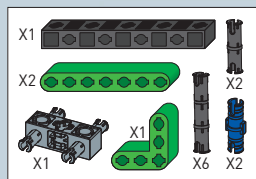

3



4

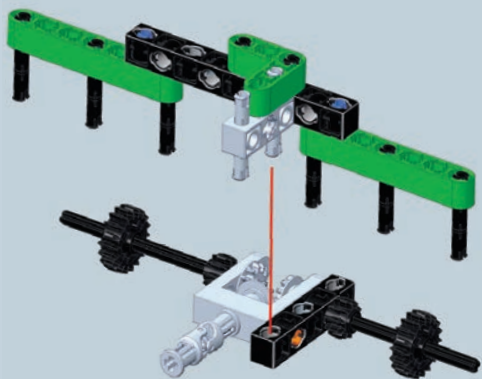

5

X2			
X2		X2	X2

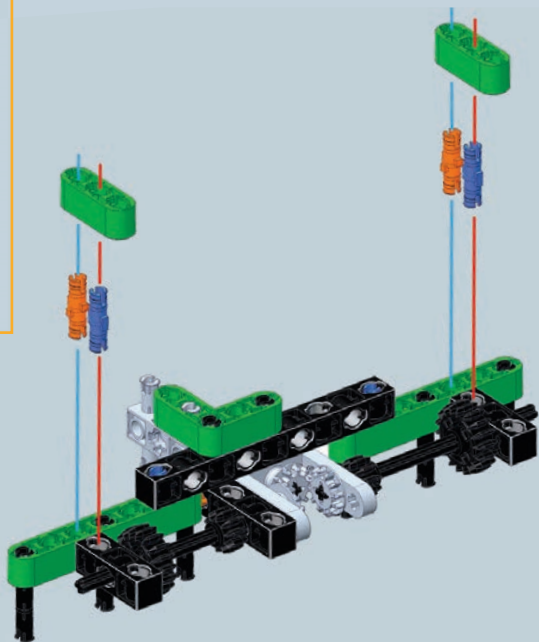

6



Model złożony w zadaniu 2

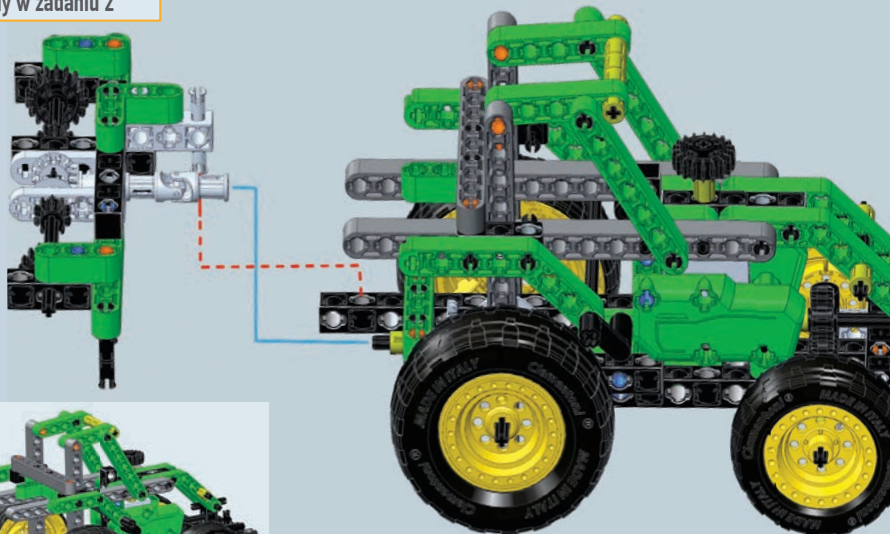

Model końcowy



4

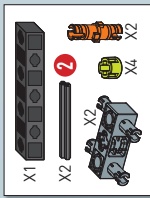
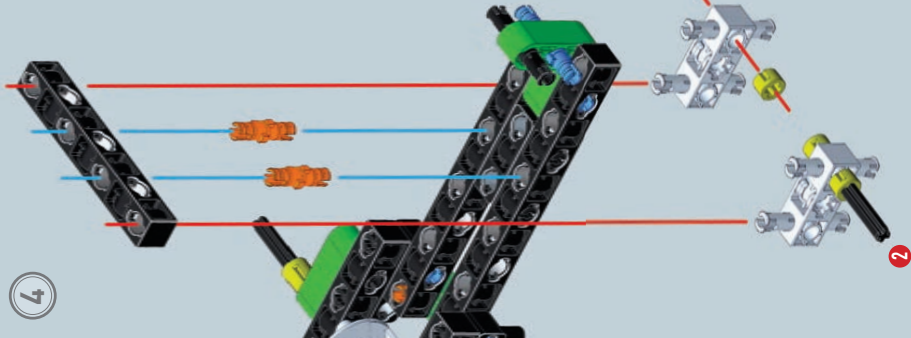

5

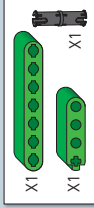
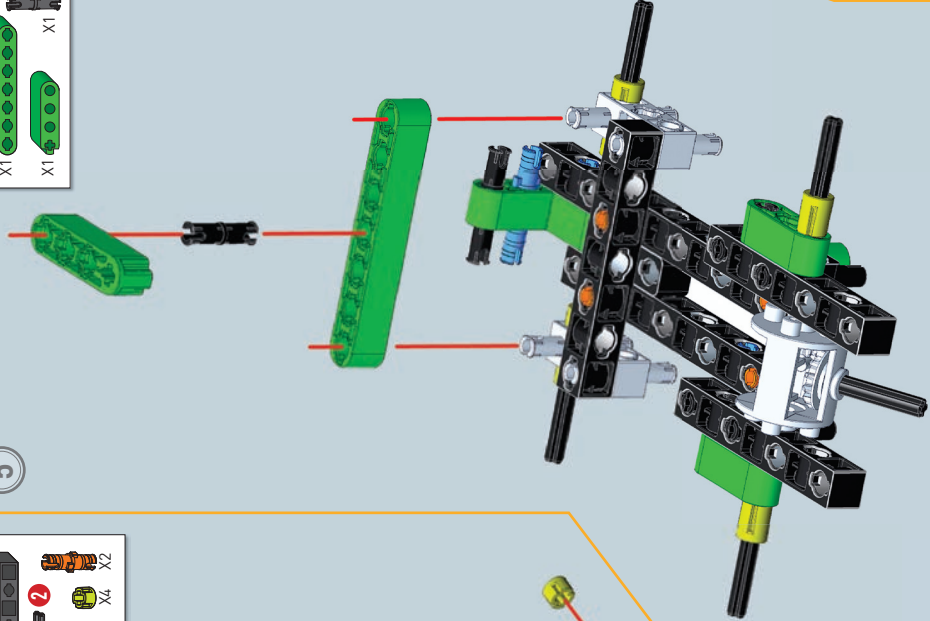

6

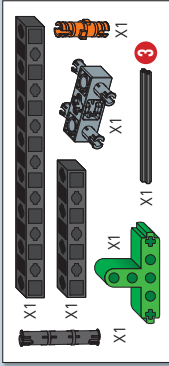
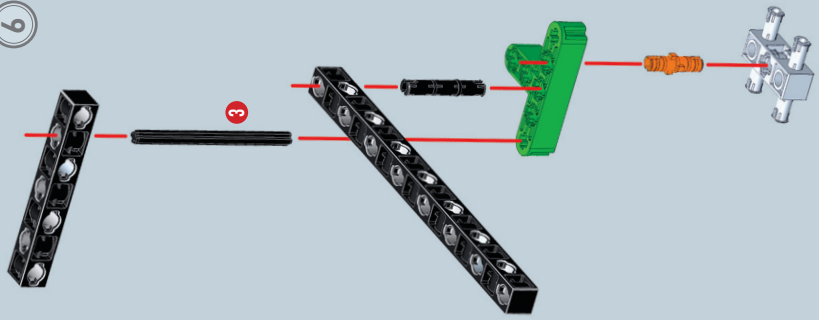

7

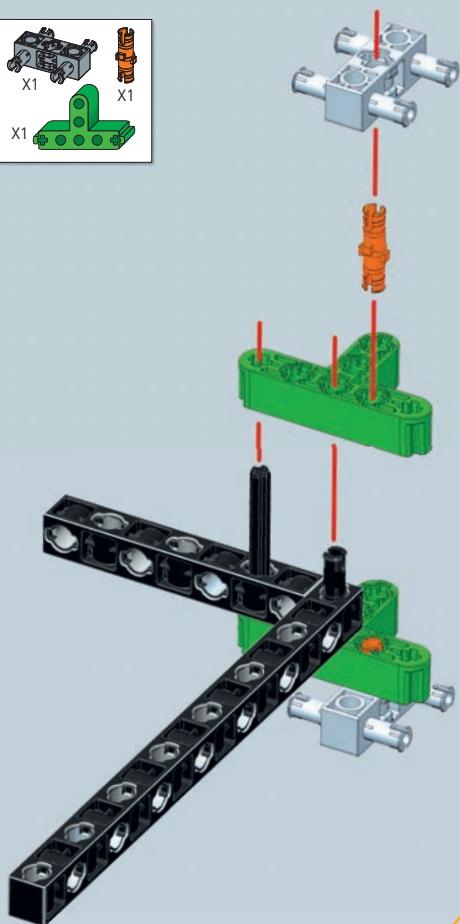
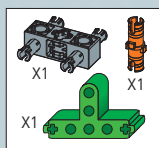

8

Nowości techniczne i ciekawostki

Po ścięciu, produkt jest kierowany do otrząsarki, obrotowego bębna z wypustami, z płaszczem zewnętrznym: mechaniczne działanie tarcia generowanego podczas obrotu umożliwia oddzielenie ziarna od odpadu. Ziarno zostaje zebrane do pojemnika wewnętrznego, natomiast odpady są wyrzucane po stronie tylnej.

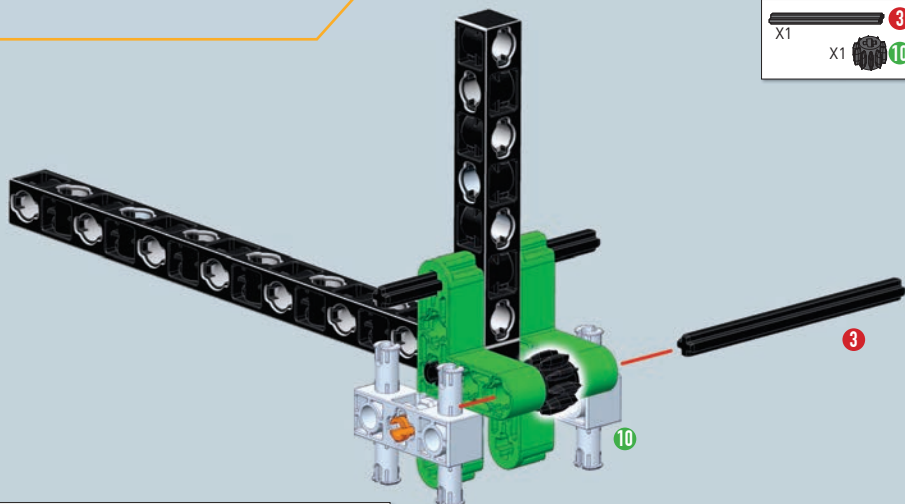

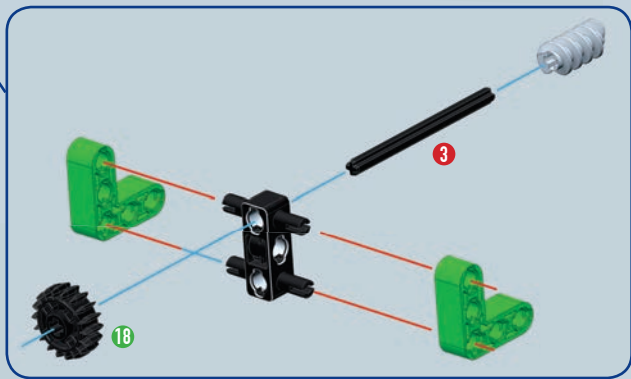
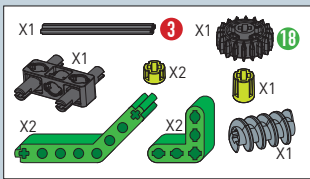
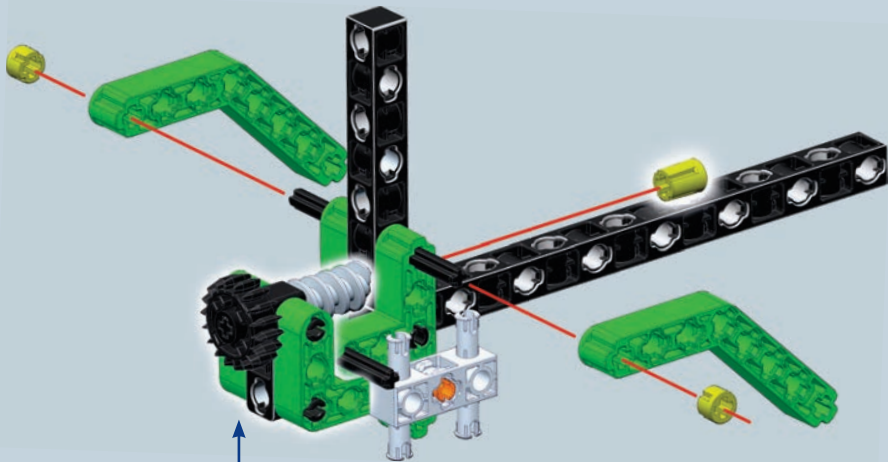

9



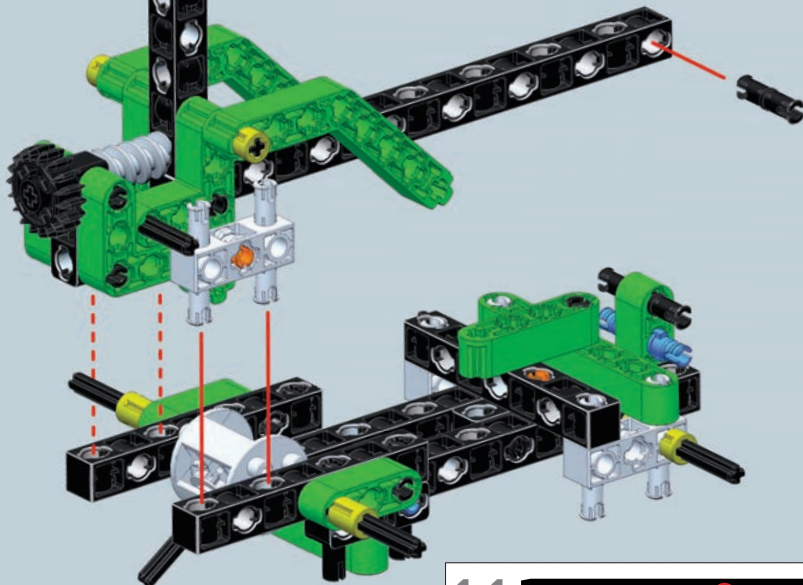

10



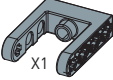

X1  6

X1  X1

X1  X1

X2  X2

X1  41

X4  X4

180°

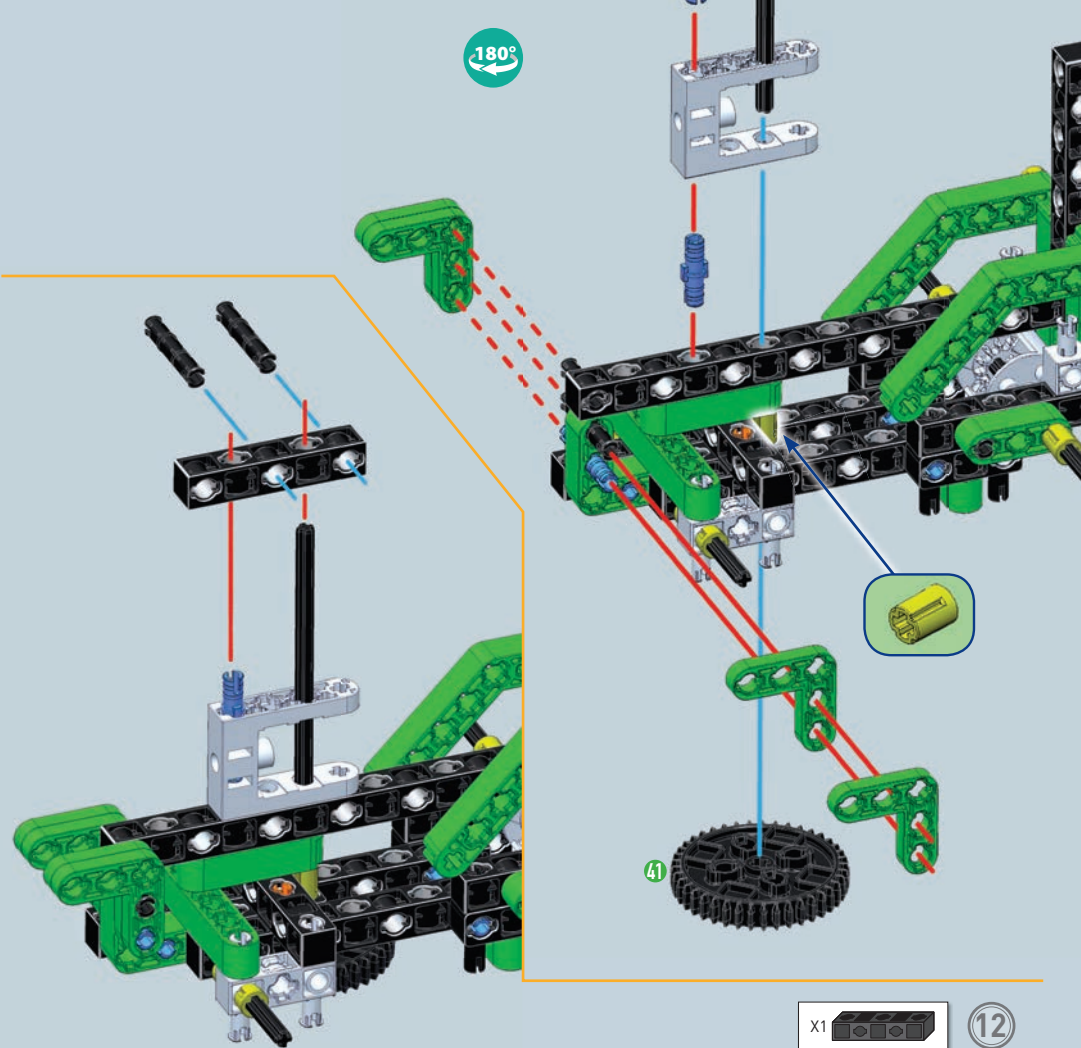

X1  X1

X2  X2

13

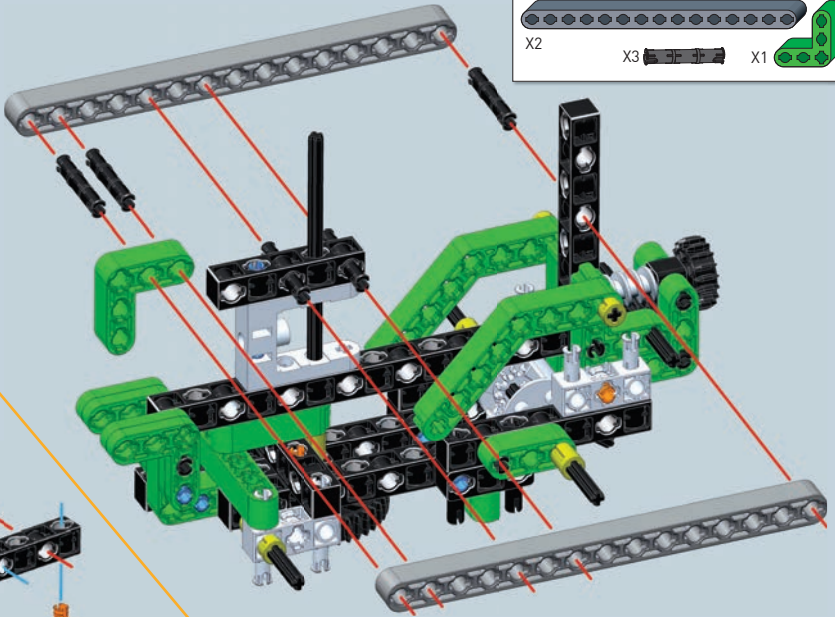

14

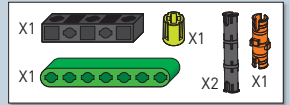
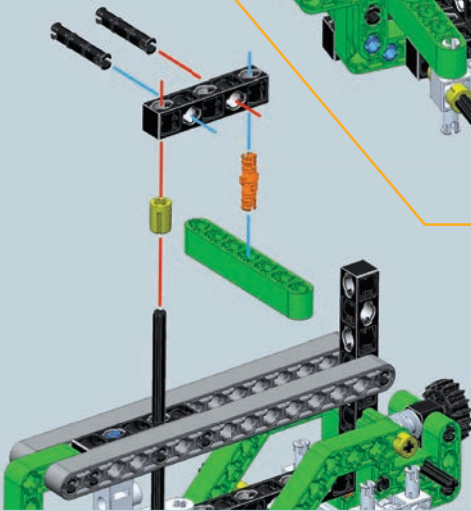

15

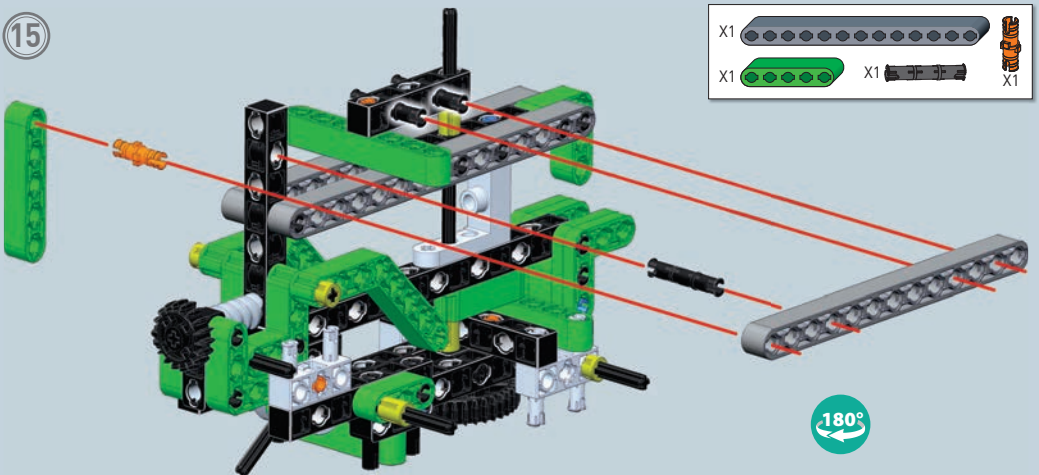
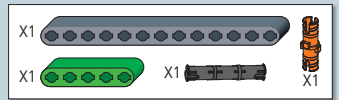

16

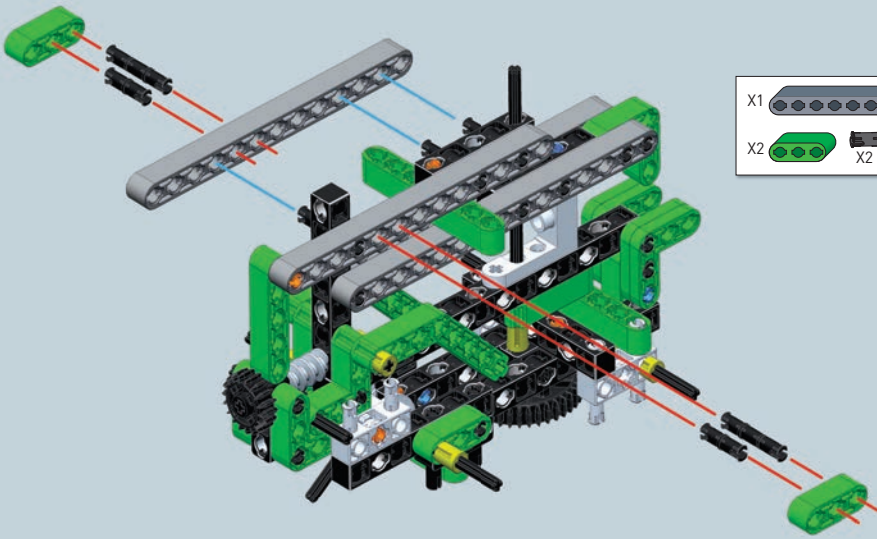

- X1
- X2 X2

17

- X2 X2
- X1 X1

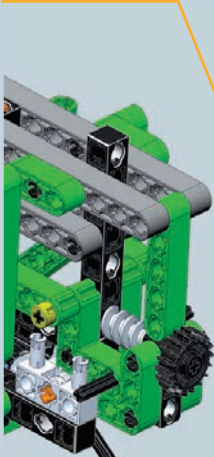
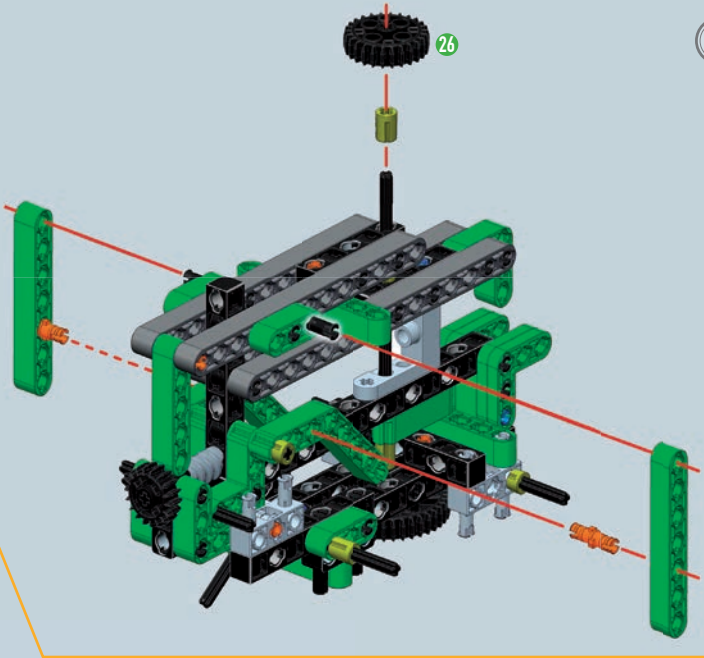

Aby złożyć przegub Cardana przestrzegaj instrukcji przytoczonych w ilustrowanej ulotce z ostrzeżeniami.

- X1
- X1
- X3
- X1

18

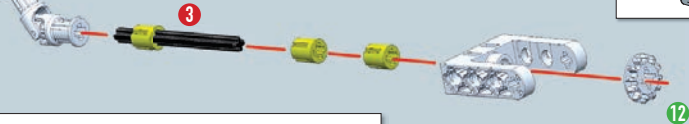

- X1
- X1
- X2
- X2
- X4
- X5
- X1
- X1

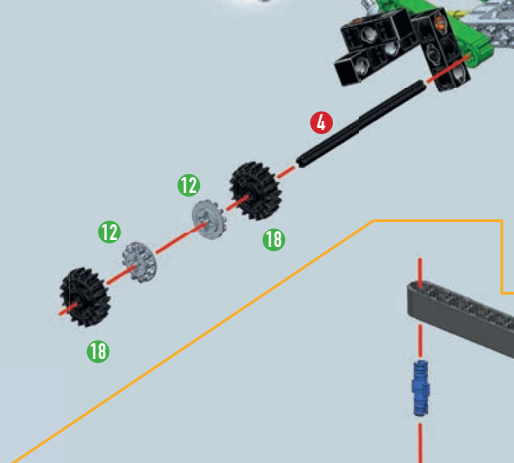
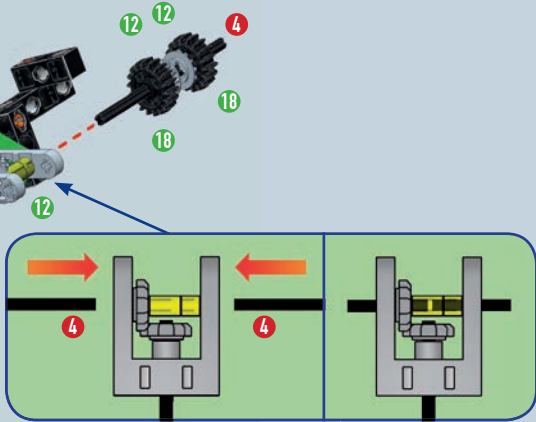
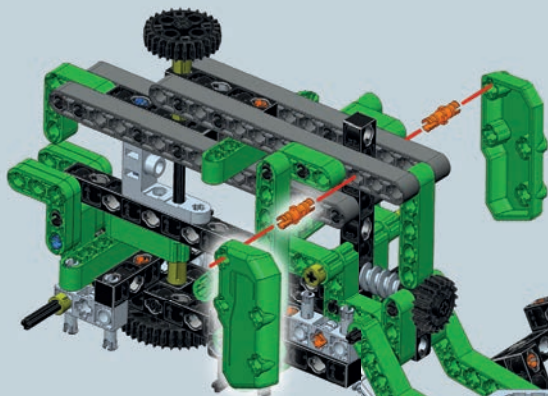

- X1
- X2
- X2
- X2
- X2

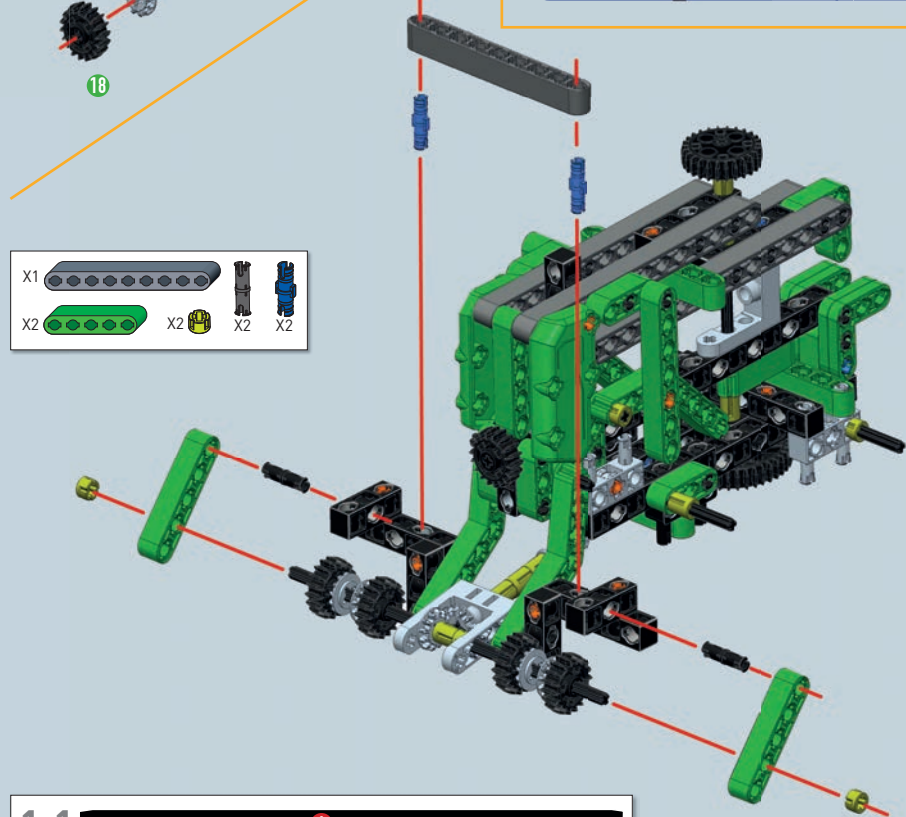

24

- X1
- X1
- X1
- X2
- X1
- X3
- X1
- X1

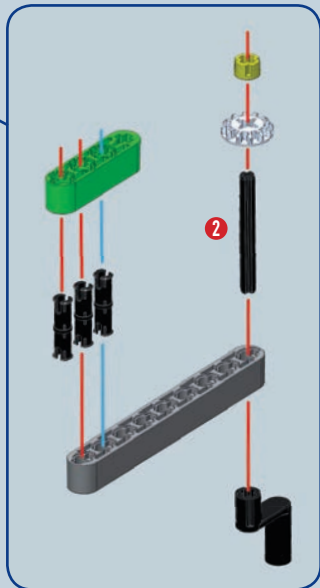
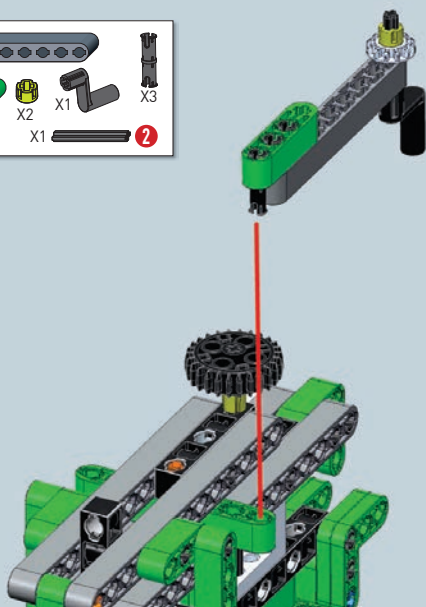

25

- X2
- X2
- X2
- X2
- X2
- X2
- X2

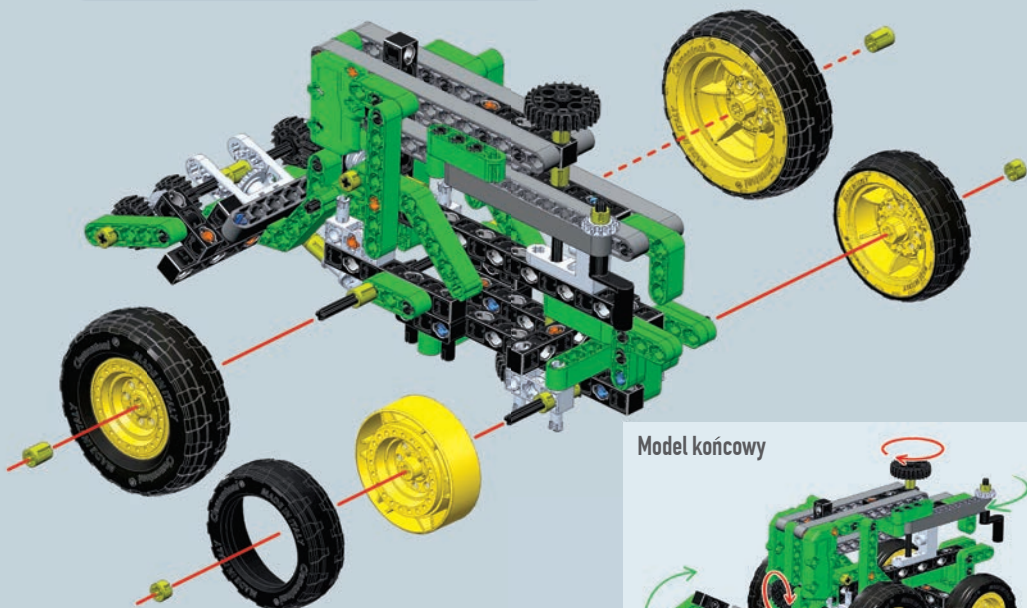

Model końcowy

