

MECHANICS

Laboratory

TRANSPORT TRUCKS

Models from **1** to **10**

- 1 - How the differential works
- 2 - The ancient lorry
- 3 - The haul truck
- 4 - The European lorry
- 5 - Work equipment: log gripper
- 6 - Work equipment: the tipper bed
- 7 - Work equipment: the tow truck
- 8 - Work equipment: the crane arm
- 9 - Work equipment: the snow plough
- 10 - The American truck



V42507

UK SUBSIDIARY:
Clementoni UK Ltd.





















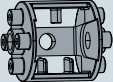



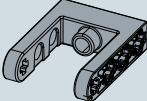





















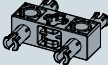

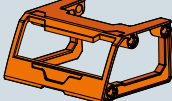

Unit 10 - Brook Business Centre -
Cowley Mill Road - UXBRIDGE - UB8 2FX
P. +44 203 383 2020 - uk@clementoni.com

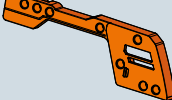
MANUFACTURER: Clementoni S.p.A.

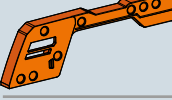
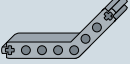
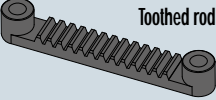
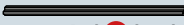
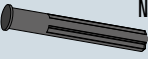
Zona Industriale Fontenoce s.n.c.
62019 Recanati (MC) - Italy
Tel.: +39 071 75811 - www.clementoni.com

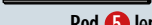
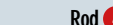
Read and keep this booklet for future reference

PARTS LIST

| | | | | | | | | |
|--|----------------------|-------|---|------------------------|--------|--|------------------------|-------|
|  | Double beam 15 holes | 2 pcs |  | Short collar | 12 pcs |  | Cogwheel with 10 teeth | 2 pcs |
|  | Double beam 11 holes | 2 pcs |  | Long collar | 12 pcs |  | Cogwheel with 18 teeth | 5 pcs |
|  | Double beam 9 holes | 2 pcs |  | Worm screw | 1 pc |  | Cogwheel with 26 teeth | 1 pc |
|  | Double beam 7 holes | 6 pcs |  | Differential cage | 1 pc |  | Cogwheel with 41 teeth | 1 pc |
|  | Double beam 5 holes | 6 pcs |  | Cogwheel with 32 teeth | 1 pc |  | Transmission module | 2 pcs |
|  | Double beam 3 holes | 6 pcs |  | Cogwheel with 24 teeth | 1 pc |  | Tyre | 4 pcs |
|  | Single beam 15 holes | 2 pcs |  | Cogwheel with 12 teeth | 9 pcs |  | 8-hole wheel rim | 2 pcs |
|  | Single beam 13 holes | 2 pcs |  | Short double peg | 16 pcs |  | 4-hole wheel rim | 2 pcs |
|  | Single beam 9 holes | 2 pcs |  | Short single peg | 8 pcs |  | Single beam 7 holes | 4 pcs |
|  | Single beam 7 holes | 2 pcs |  | Short free peg | 32 pcs |  | Single beam 5 holes | 4 pcs |
|  | Single beam 5 holes | 2 pcs |  | Long double peg | 8 pcs |  | Single beam 3 holes | 4 pcs |
|  | Single beam 3 holes | 2 pcs |  | Long free peg | 16 pcs |  | T-shaped beam | 4 pcs |
|  | Tall L-shaped beam | 2 pcs |  | Beam with pegs | 4 pcs |  | Short L-shaped beam | 4 pcs |
|  | Short L-shaped beam | 2 pcs |  | Beam with pins | 6 pcs |  | Mobile crane cabin | 1 pc |
|  | Beam 4 holes | 2 pcs |  | Hook | 1 pc |  | RH cabin panel | 1 pc |
|  | T-shaped beam | 2 pcs |  | Crank | 2 pcs |  | LH cabin panel | 1 pc |
|  | L-shaped beam | 4 pcs |  | Toothed rod | 1 pc | | | |
|  | Rod 7 length 9.9 cm | 1 pc |  | Nail-like rod | 2 pcs | | | |
|  | Rod 6 length 11.7 cm | 1 pc | | | | | | |
|  | Rod 5 length 8.1 cm | 1 pc | | | | | | |
|  | Rod 4 length 7.2 cm | 1 pc | | | | | | |
|  | Rod 3 length 5.4 cm | 5 pcs | | | | | | |
|  | Rod 2 length 3.6 cm | 2 pcs | | | | | | |
|  | Rod 1 length 2.7 cm | 1 pc | | | | | | |

The internal combustion engine

The internal combustion engine is a machine that converts chemical energy into mechanical power. To generate mechanical power we need:

Fuel: gas, petrol or diesel



Oxidant: oxygen



Combustion chamber: the container in which the combustion reaction takes place between the fuel and oxidant.

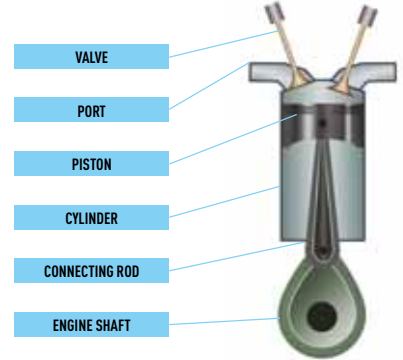

How does it work? Combustion occurs in 4 phases:



PHASE 1

Intake:
the piston lowers.
The air or air/fuel mix is sucked into the cylinder.



PHASE 2

Compression:
the piston rises.
The air/fuel mix is compressed.
Combustion starts.



PHASE 3

Ignition and Expansion:
the piston lowers.
Combustion occurs, causing the gases to expand instantly. The piston is pushed downwards.

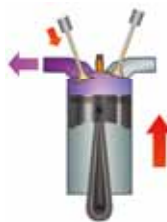

PHASE 4

Exhaust:
the piston rises.
The combustion residues are exhausted from the cylinder.

Each cycle just described causes two rotations of the engine shaft, which then transmits motion to the other mechanical parts of the vehicle.

Petrol engine vs diesel engine. A petrol engine and a diesel engine differ with regard to the ignition phase:



PETROL ENGINE

It is a controlled-ignition engine. The air/fuel mix is ignited thanks to an electric charge.

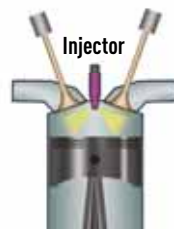

DIESEL ENGINE

It is a spontaneous-ignition engine. The fuel is injected into the cylinder only after the compression phase. The compressed air reaches such high temperatures that the fuel ignites.

The hydraulic cylinder

Transport trucks can be fitted with work equipment driven by specific actuators, which exploit the pressure of the hydraulic oil to complete a movement.

The hydraulic piston is an actuator consisting of two mechanical parts:

- the cylinder, consisting of an empty cylindrical body
- the piston or rod, consisting of a full round body

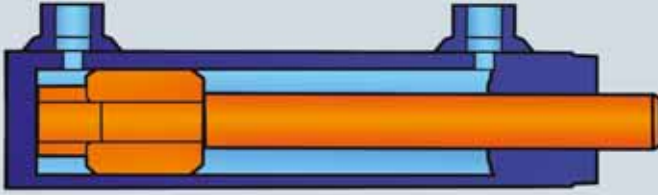

CYLINDER

CAVITY FOR HYDRAULIC OIL

PISTON OR ROD

How does it work? The hydraulic piston consists of a double-acting cylinder, in which the hydraulic oil can be introduced from two ends, under the operator's control.

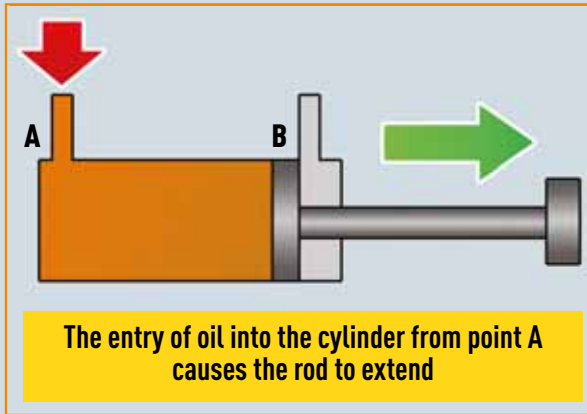

The entry of oil into the cylinder from point A causes the rod to extend

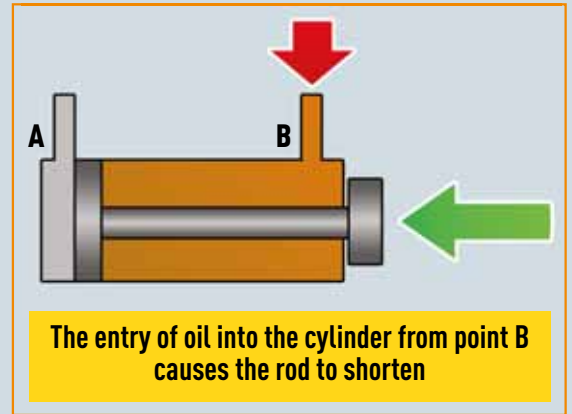

The entry of oil into the cylinder from point B causes the rod to shorten

Hydraulic circuit

Hydraulic oil travels inside a closed circuit.

The oil is sucked from a storage tank by a first pump and sent to the distributor.

The distributor opens and closes the two access routes to the piston, causing – under the operator's control – the rod to extend or return.

Being a closed circuit, the oil pushed thrust out from one side of the cylinder is discharged again to the tank by means of the distributor.

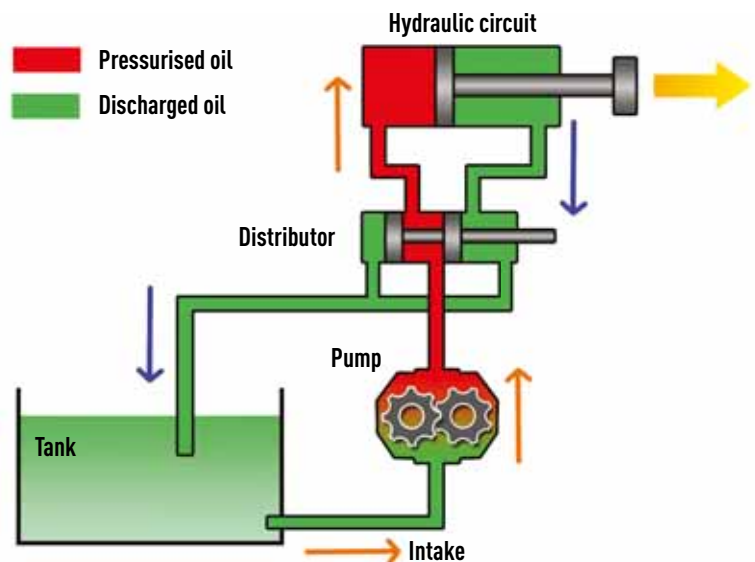

1 How the differential works



Technical and scientific analysis

The differential is a mechanical device capable of transferring the power generated by the engine to the drive wheels.



- 1 **Pinion:** transfers power from the engine to the crown wheel and ultimately to the drive wheels.
- 2 **Crown wheel:** it is attached to the differential cage and permanently coupled with the pinion.
- 3 **Differential cage:** box that houses the gears.
- 4 **Spider gears:** gears bound to the cage.
- 5 **Side gears:** gears attached to the axle shafts.
- 6 **Axle shaft:** axle that connects the drive wheels to the side gears.

It is designed to allow the two wheels to rotate at different speeds when going round a bend. On non-straight sections, the outer wheel covers more road than the inner wheel, therefore the outer wheel has to rotate faster.



The pinion gear transfers the engine's power to the differential and, as a result, to the axle shafts.

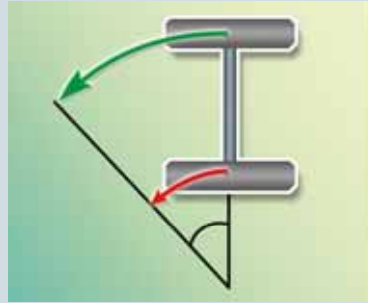

Around a bend, the inner wheel covers a shorter distance compared to the outer wheel.



Thanks to the differential, on a bend, the wheels of a vehicle rotate at different speeds.

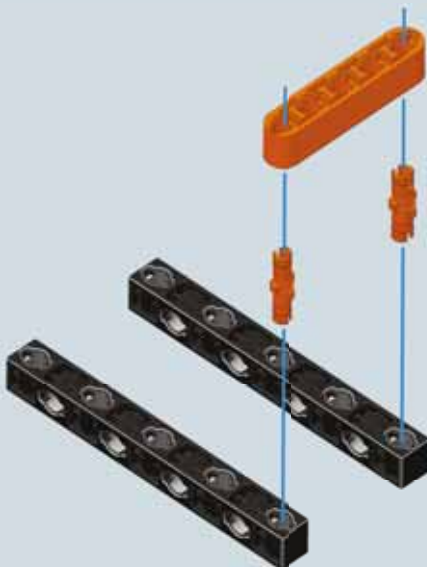

1

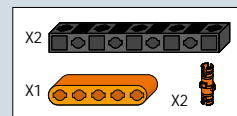

2

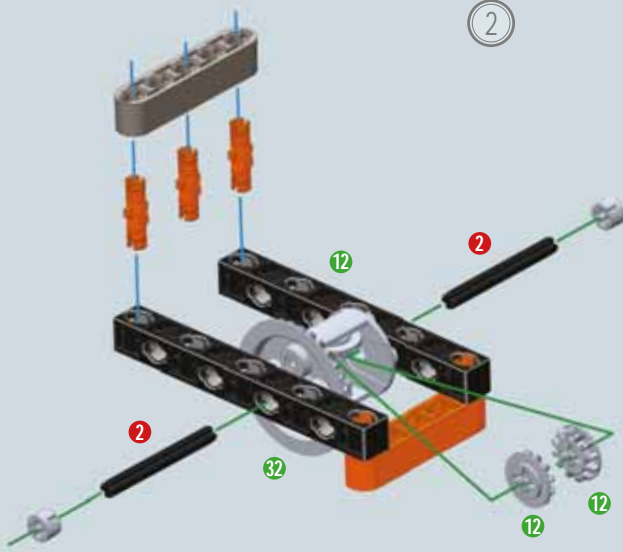

- X1
- X2
- X1
- X1
- X3
- X2
- X3

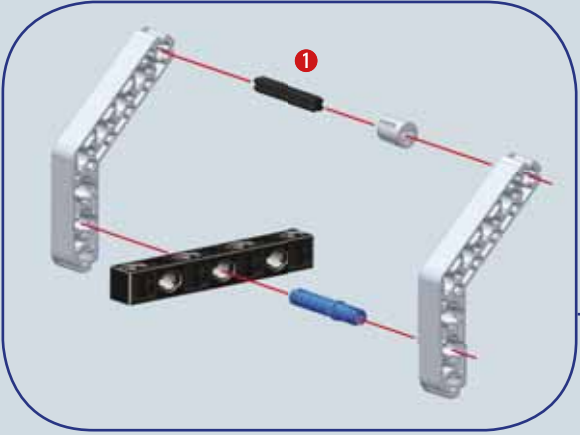
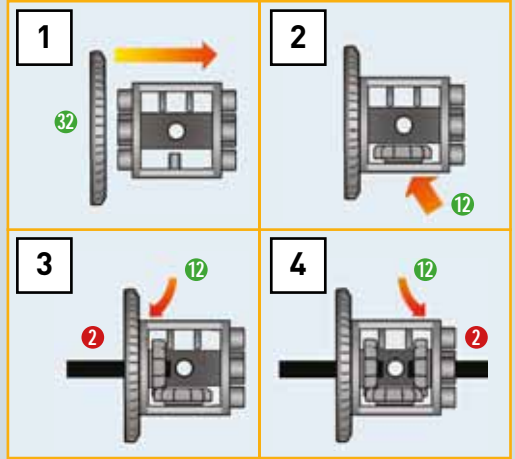

- X1
- X1
- X1
- X1
- X1
- X1
- X1
- X1
- X1
- X2
- X2
- X2
- X2

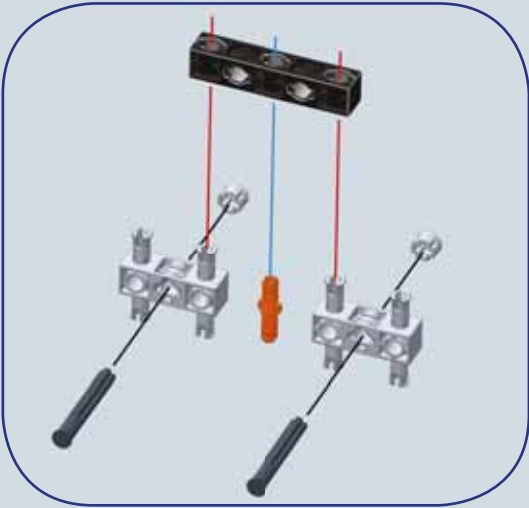

3



4

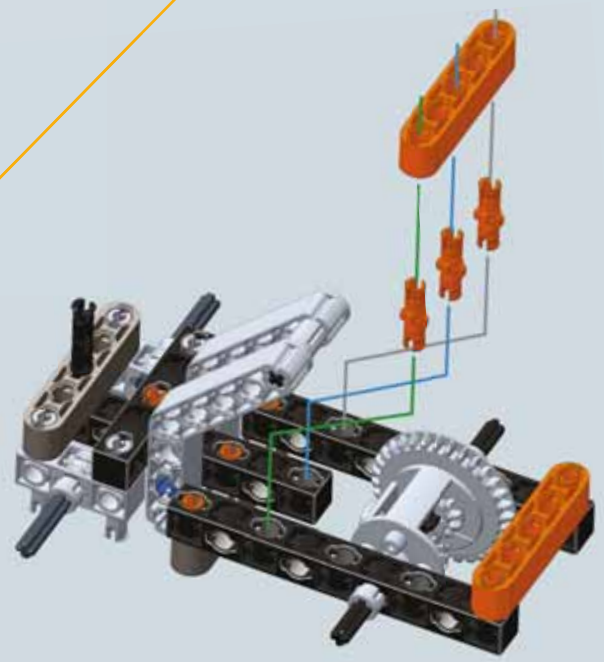
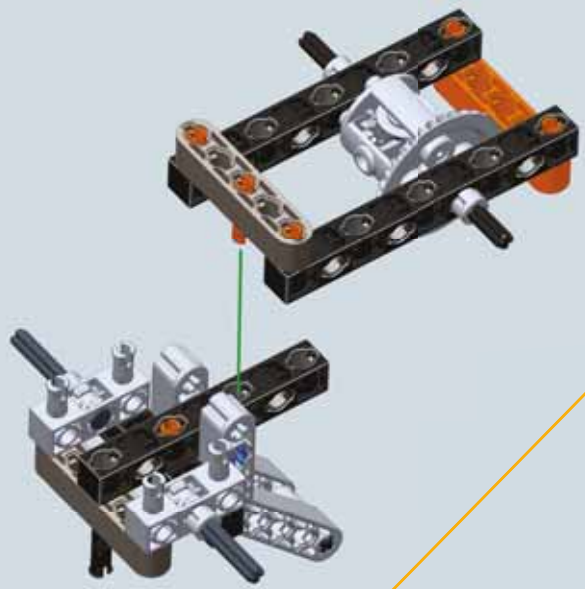

5

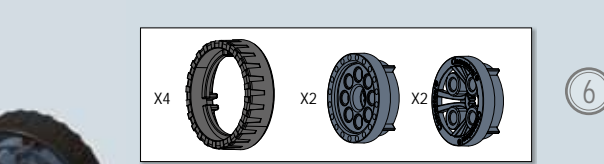
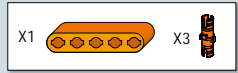

6

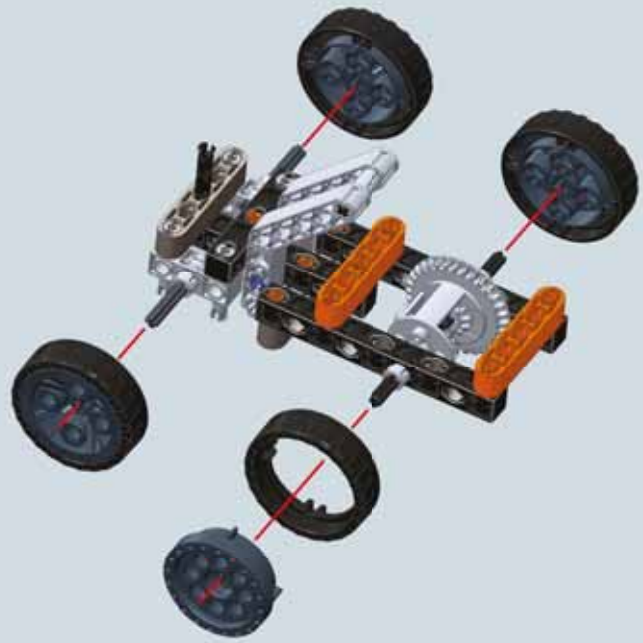

Final assembled model

2 The ancient lorry



Technical facts and curiosities

The first lorry in history was built in 1896. The initial design was very plain and was derived from the carriages of the time: the front part, to which draught animals were once attached, was eliminated in favour of an engine fitted to the lorry, capable of driving the vehicle at a speed of 16 km/h. The wheels were still made of wood, with a metal outer rim. The braking system was the same as that used on carriages.

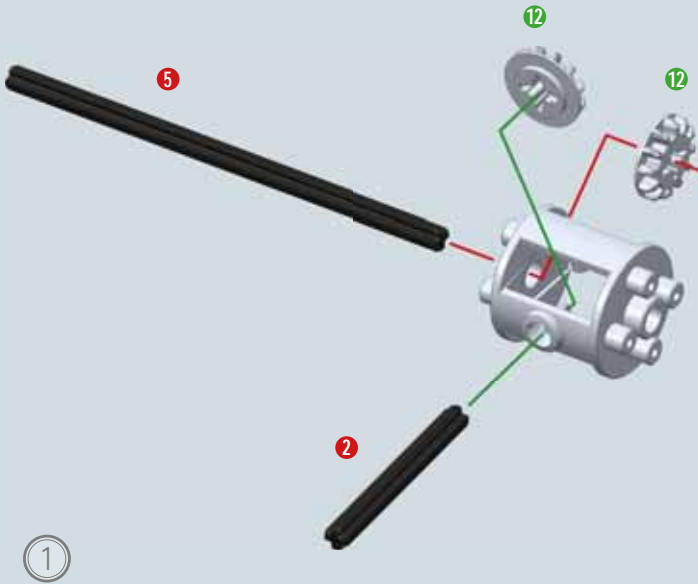

| | | |
|----|--|----|
| X1 | | 5 |
| X1 | | 2 |
| X1 | | |
| X1 | | 12 |
| X2 | | 12 |

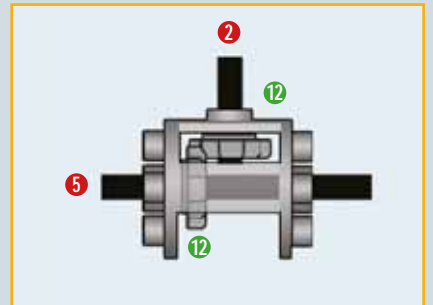

4

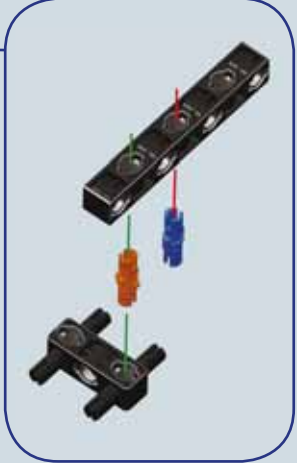
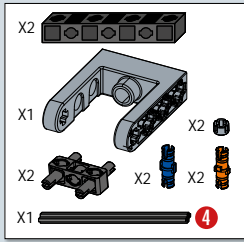
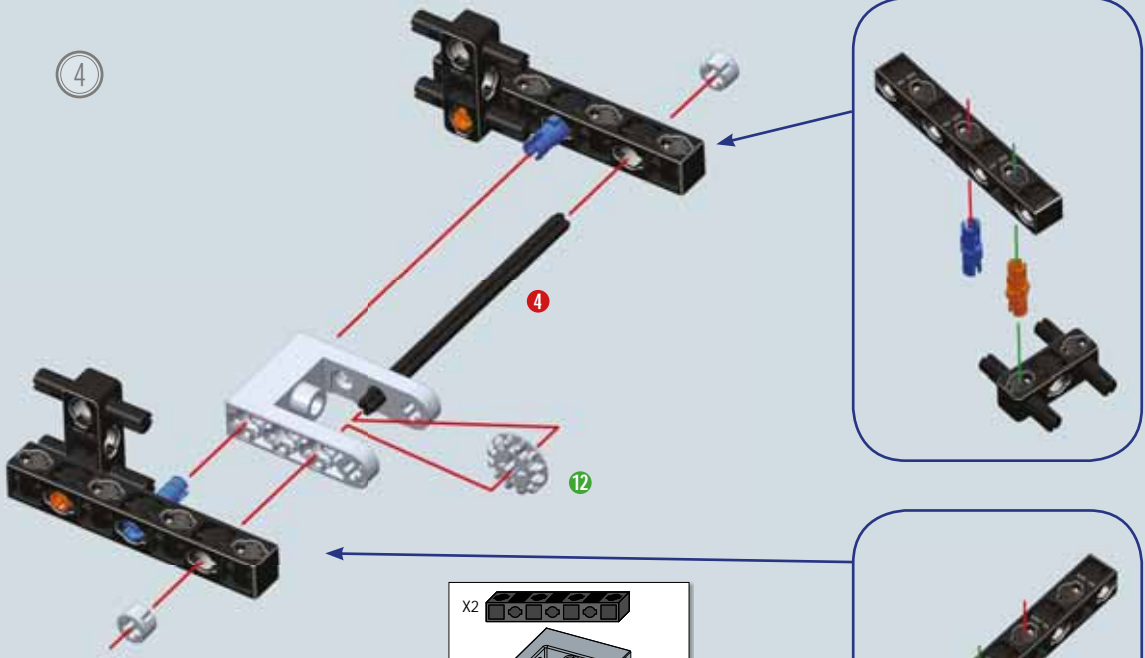

5

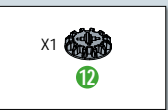
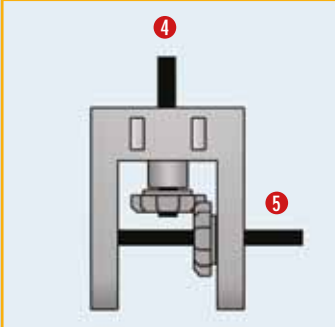
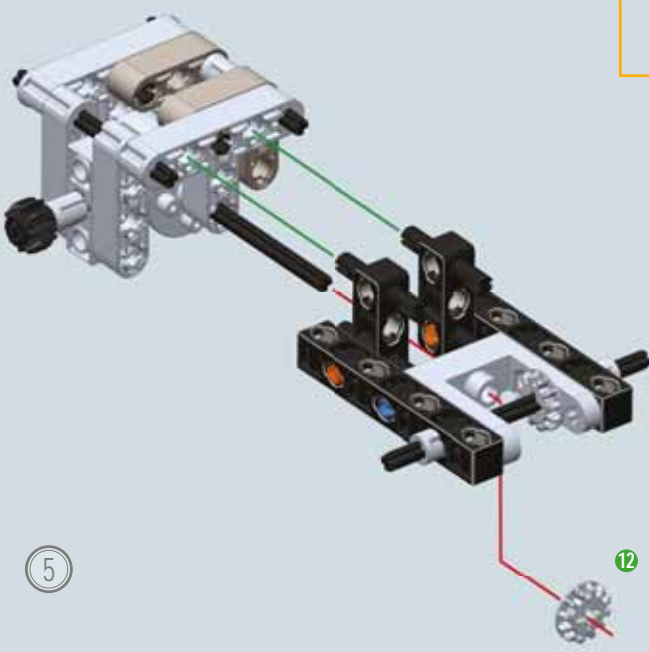

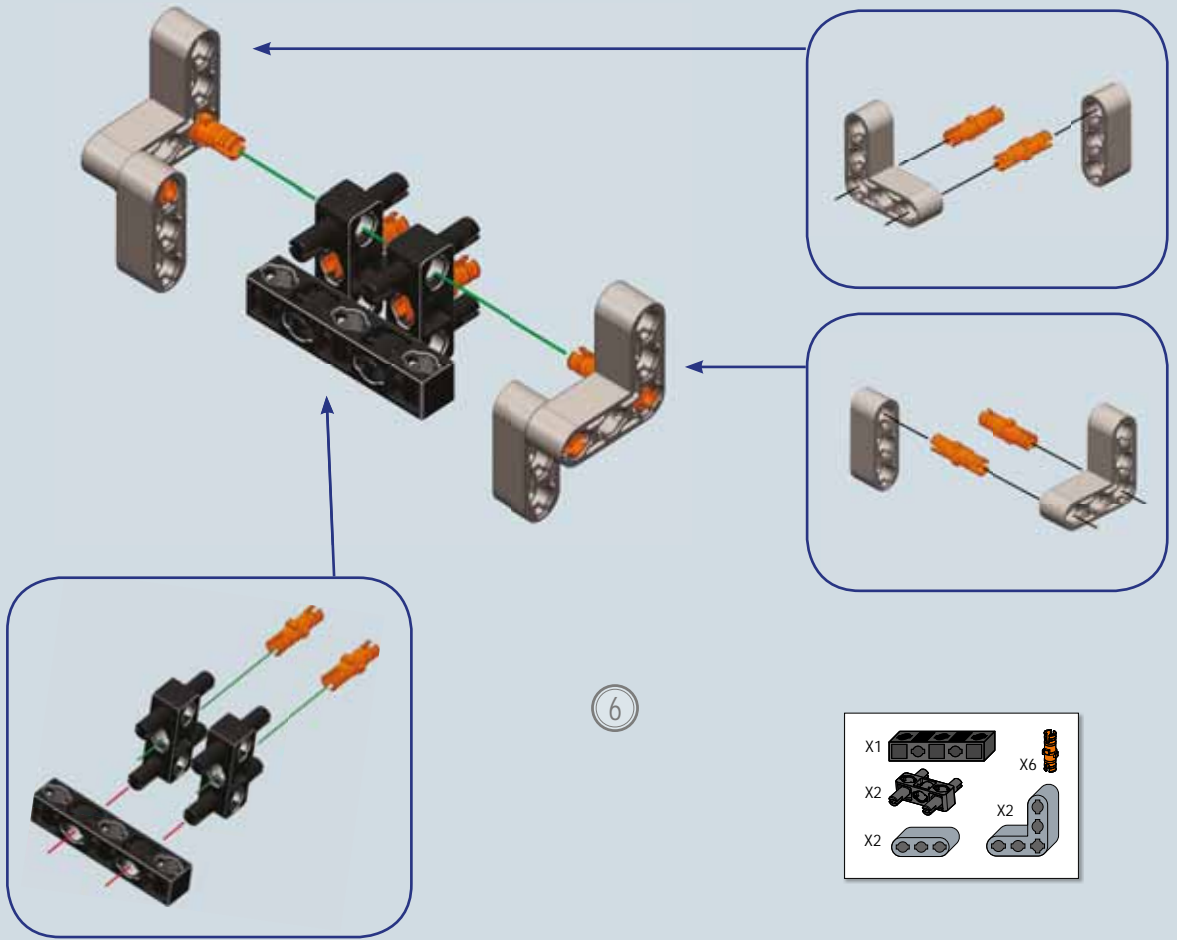

7

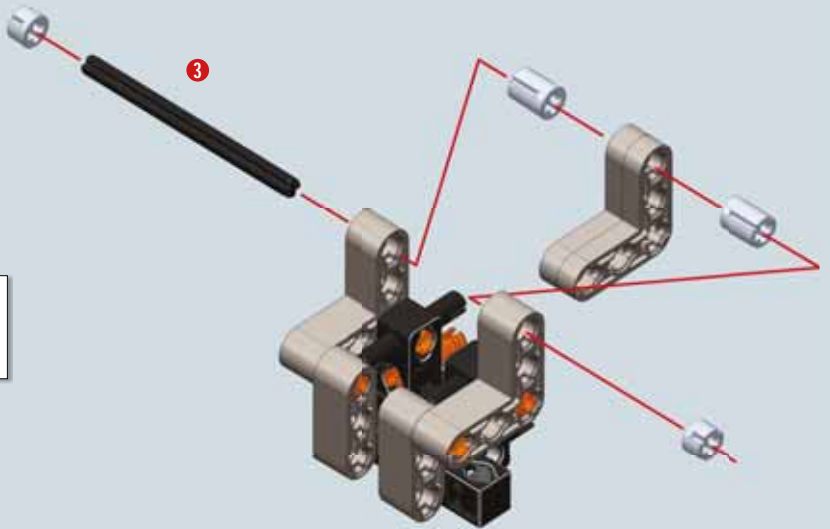
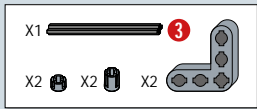

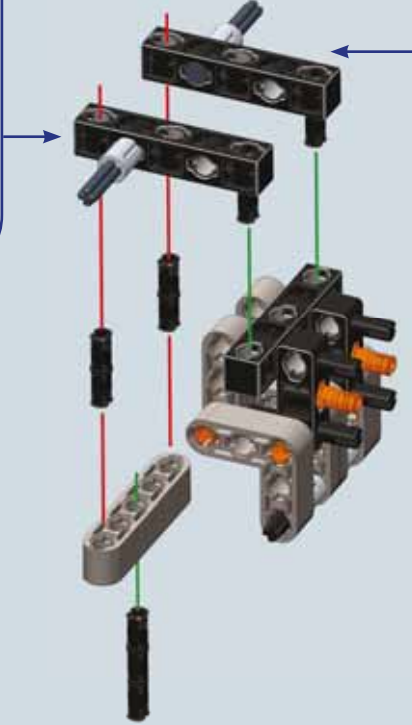
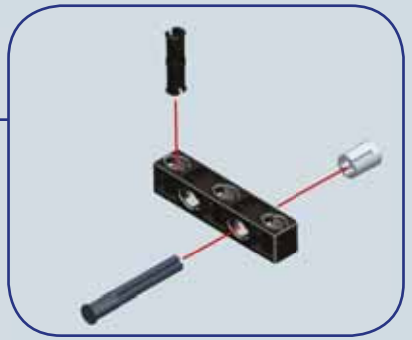

8

- | | | | |
|----|--|----|--|
| X1 | | X4 | |
| X2 | | X2 | |
| X2 | | X1 | |

9

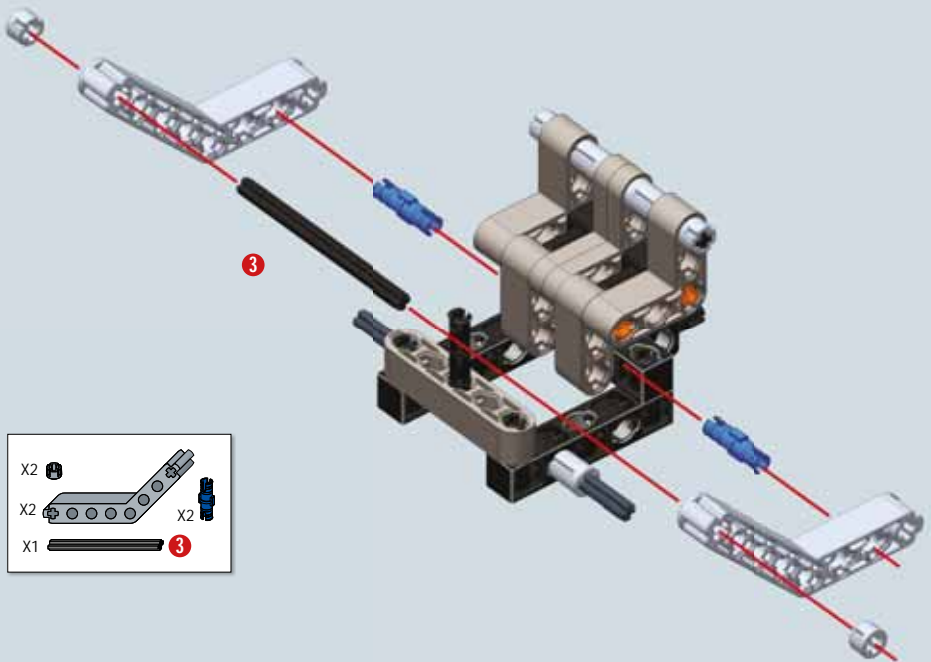

- | | | | |
|----|--|----|--|
| X2 | | X2 | |
| X2 | | X2 | |
| X1 | | | |



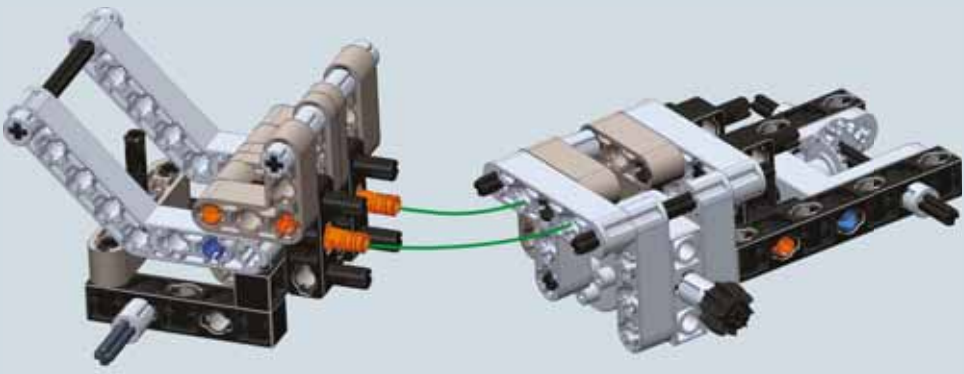

10

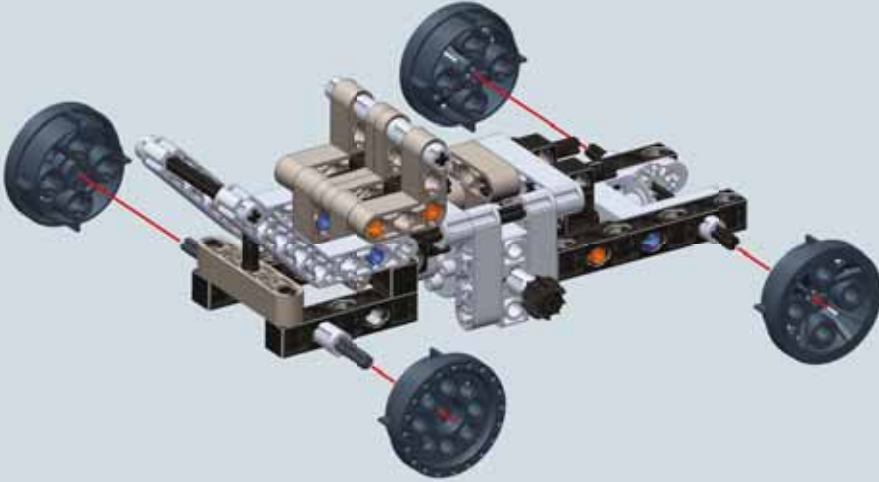

11

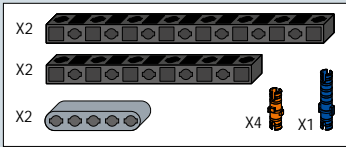
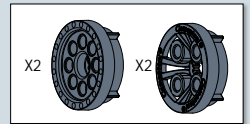

12

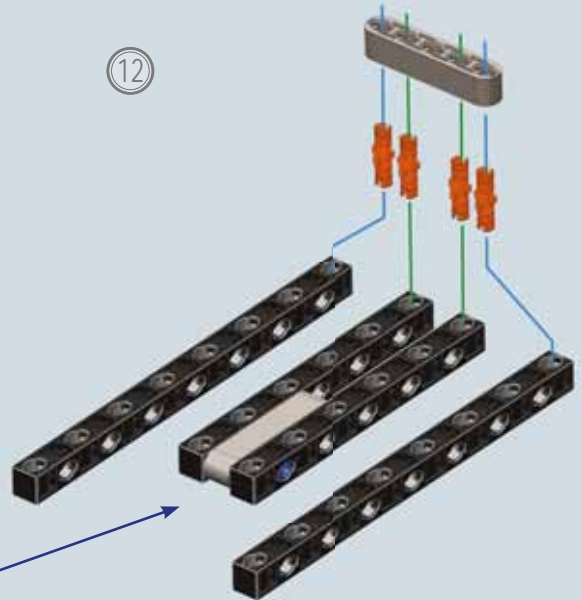
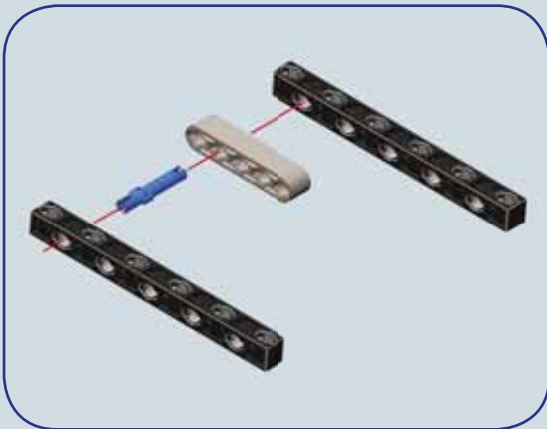

14

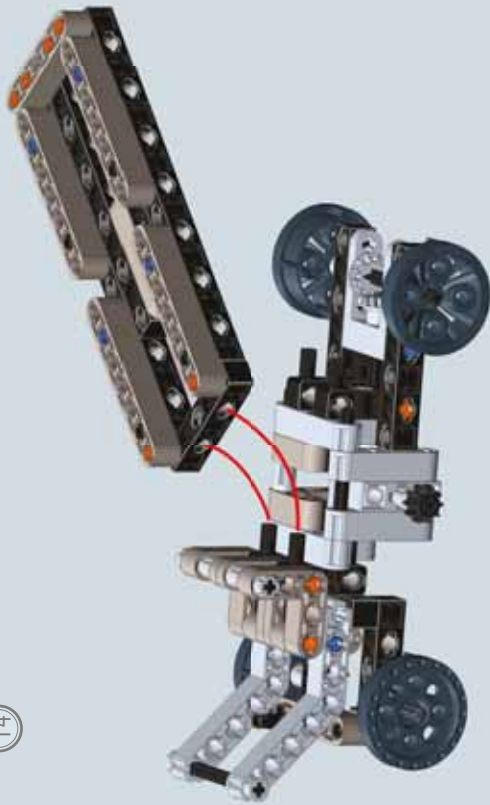

Final assembled model

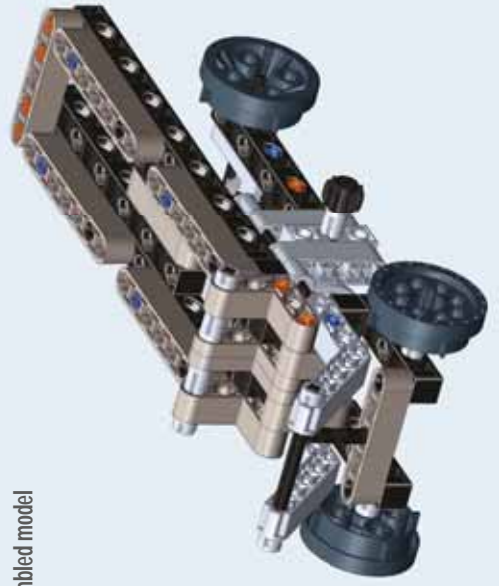

13

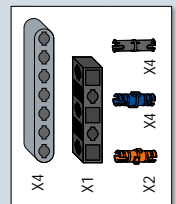
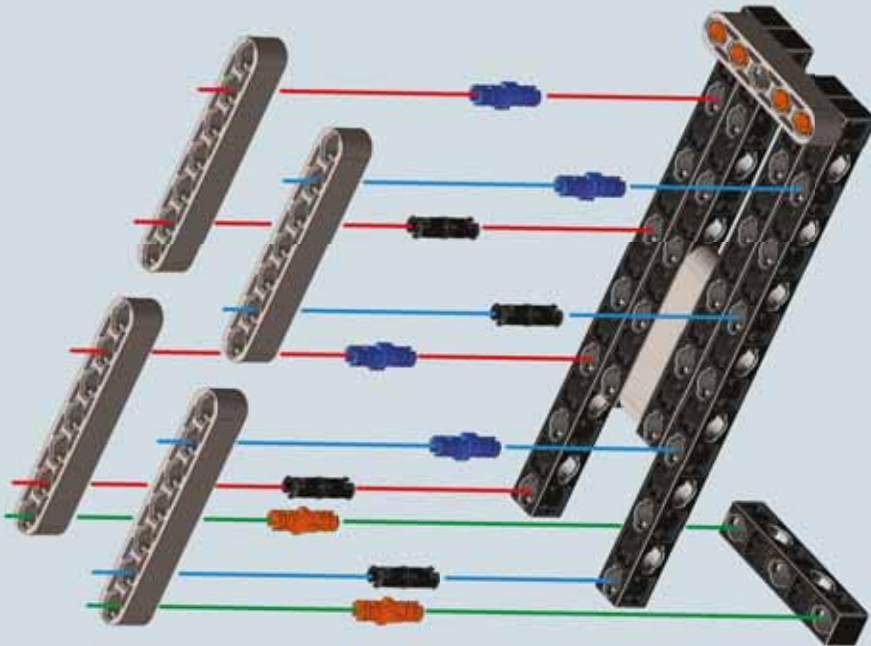

3 The haul truck



Technical facts and curiosities

Trucks used in the mining industry are actual giants on wheels. The larger models can be up to 7 metres high (like a two-storey building) and mount a diesel engine as big as a van. The bed is almost 10 metres long and can carry a considerable amount of earthy material. When fully loaded, the entire vehicle can weigh up to 600 tons. It normally has 6 wheels, which are also very large (roughly 4 metres in diameter).

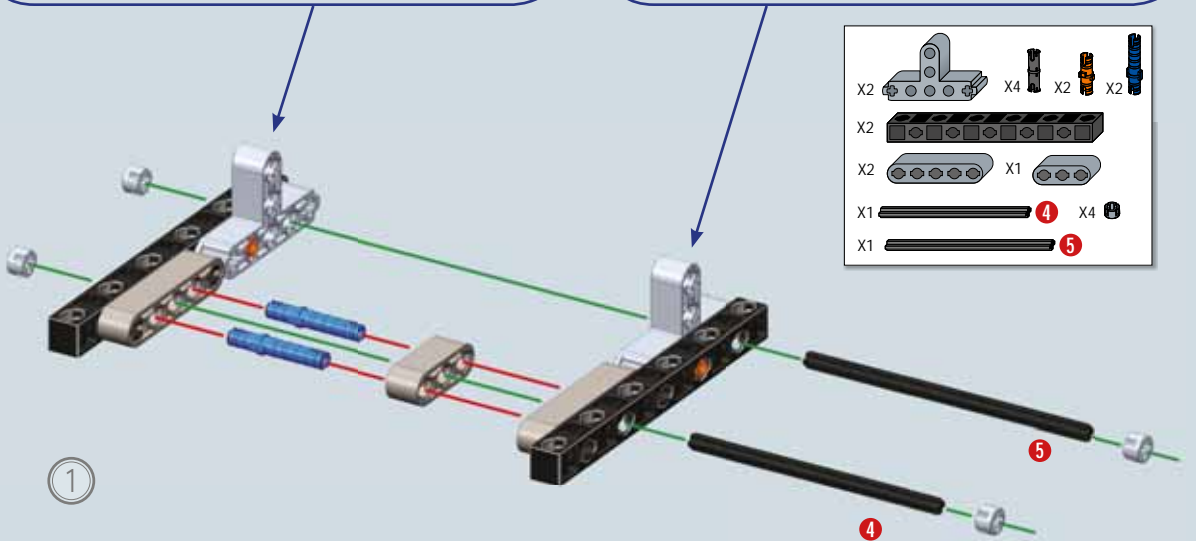
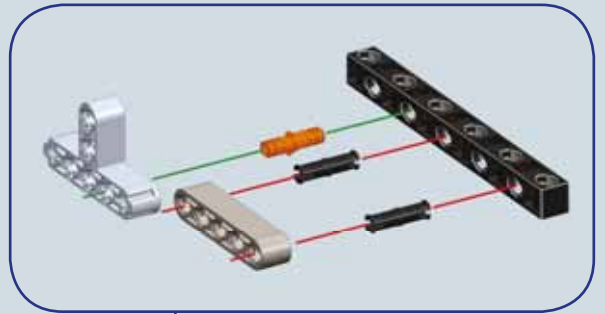
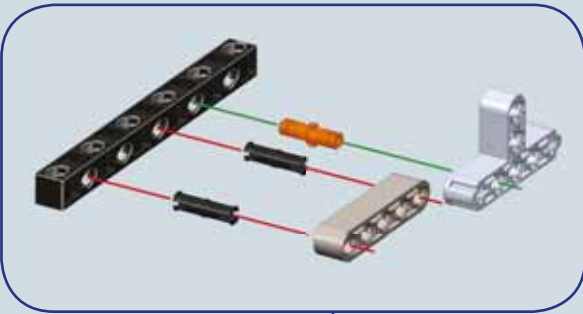

2

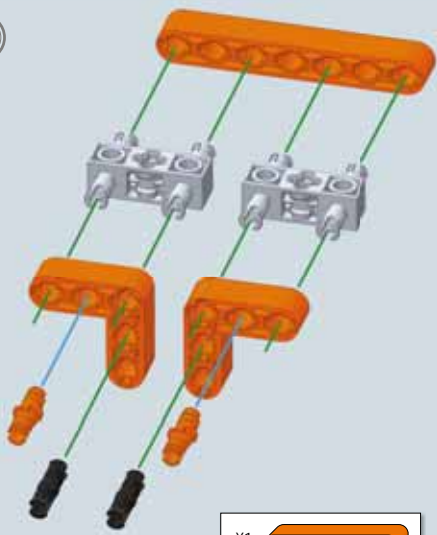

- X1
- X2 X2
- X2 X2

3



- X2
- X1
- X2 X1

4



- X1 X1 X2
- X1

5

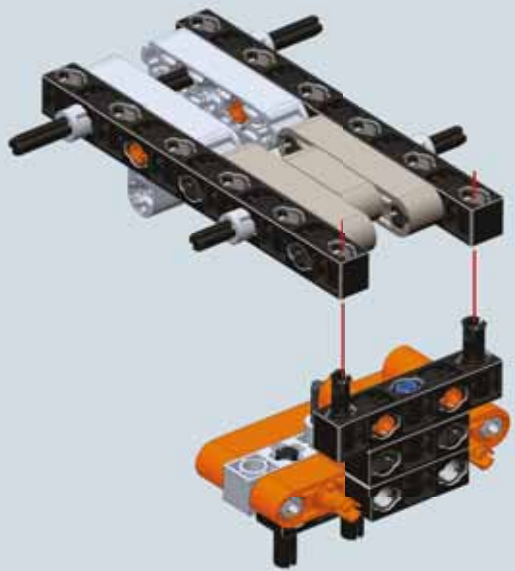

6

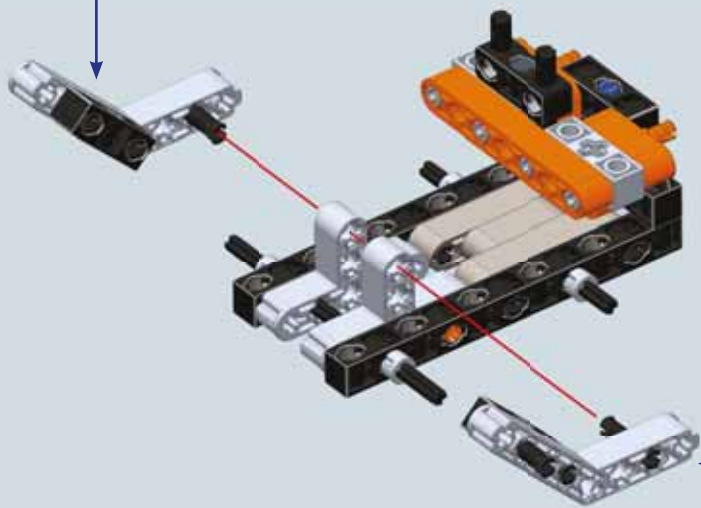
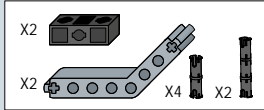

7

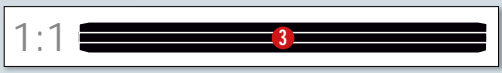
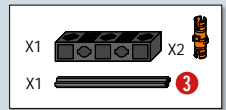
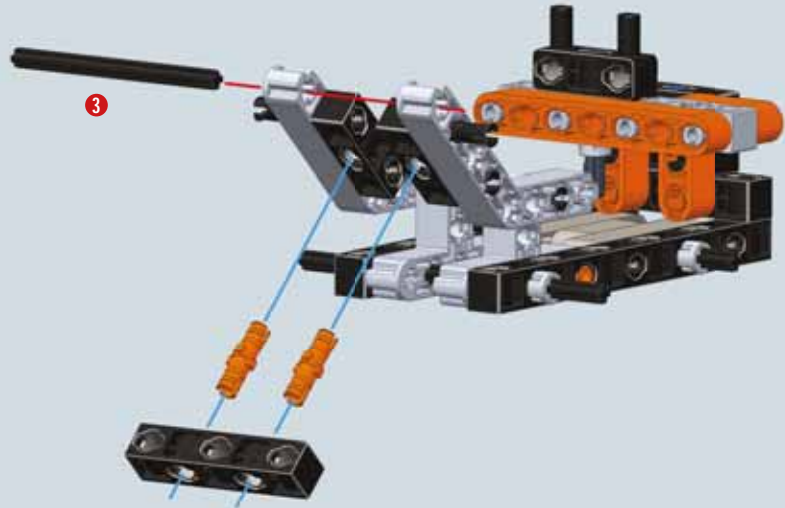

- X1
- X1
- X1
- X1
- X2
- X1
- X1
- X3
- X1

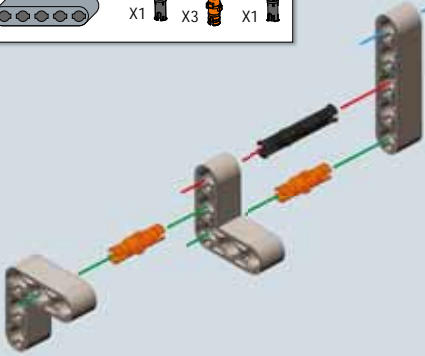

8

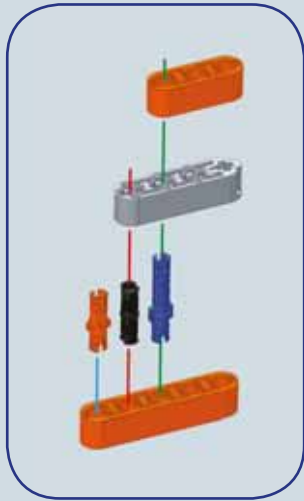
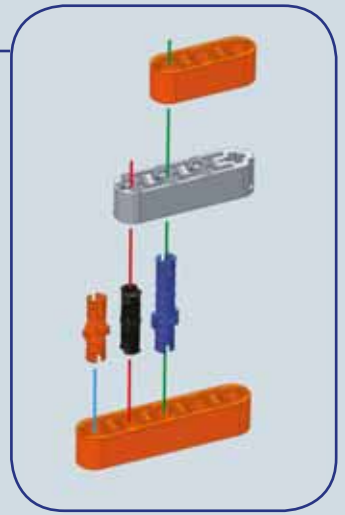

9

- X1
- X1
- X1
- X1
- X1
- X1
- X2
- X1

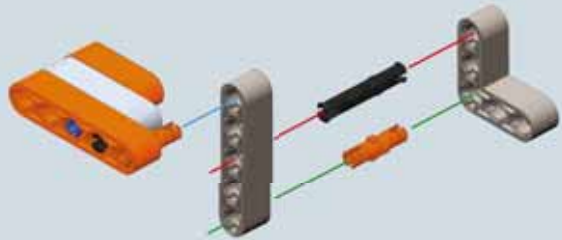

10

- X1
- X1

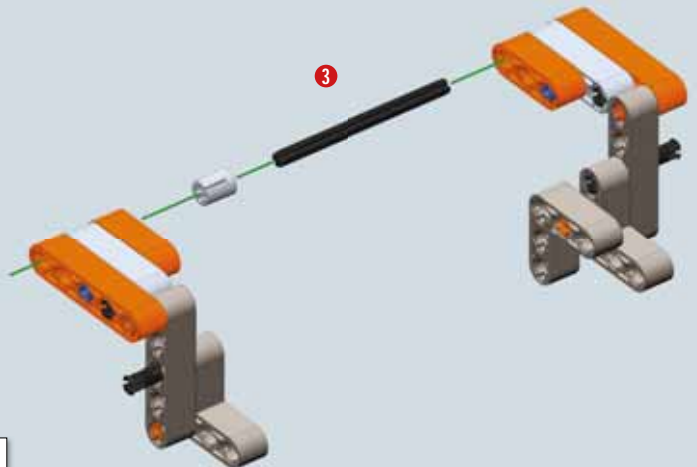

- 1:1

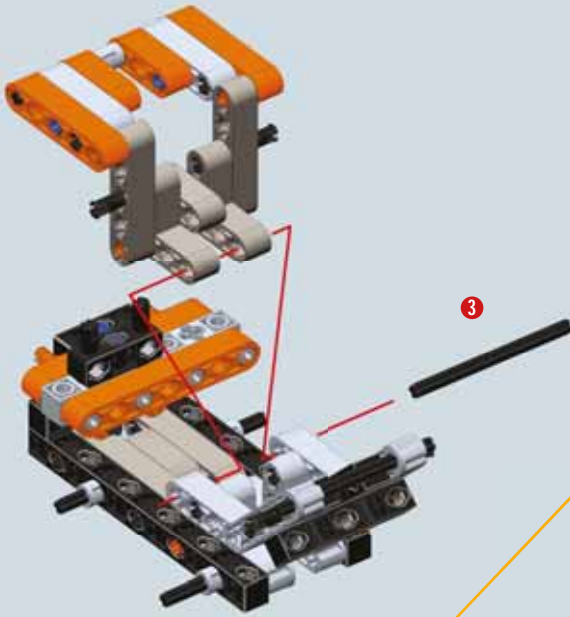

X1  3

1:1  3

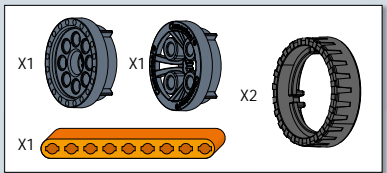
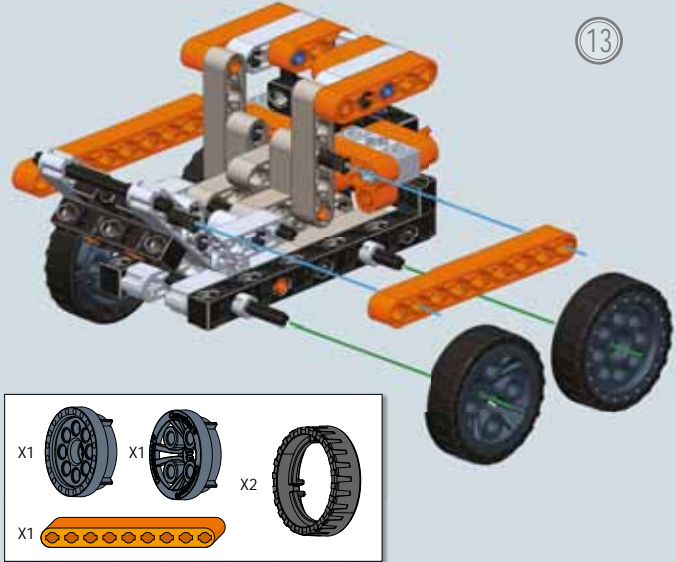
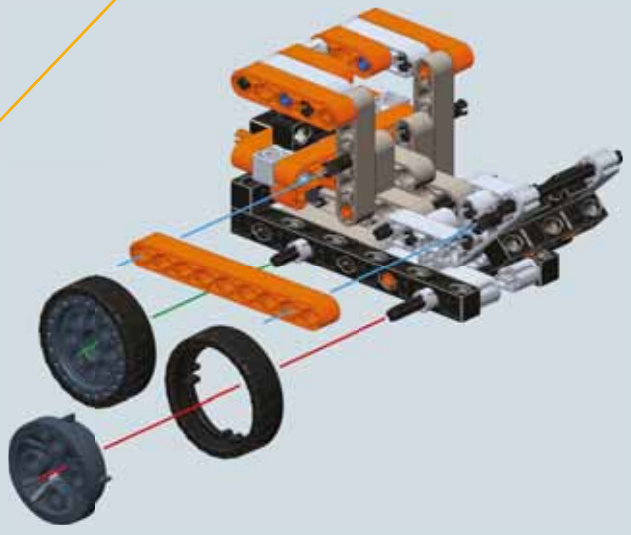
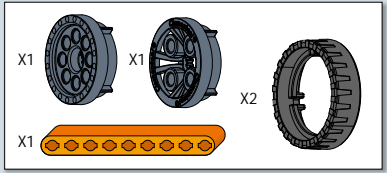

Final assembled model

4 The European lorry



Technical facts and curiosities

The lorry is a vehicle designed to transport goods. Driven by powerful diesel engines, it can have from 4 to 6 wheels. The model we'll build in this activity is actually a road tractor, in other words, a vehicle exclusively designed for hauling semi-trailers with which – once it is hooked up – it forms special complex vehicles known as articulated lorries. The difference between a lorry and a road tractor is that the latter cannot autonomously transport goods.

The flat nose, typical of European lorries, is due to the stringent regulations on vehicle dimensions introduced for safety and traffic management reasons.

In the olden days, farm tractors were also used as road tractors. However, the bodywork and tyres of these farm tractors had to be slightly modified before they could be put on the road.

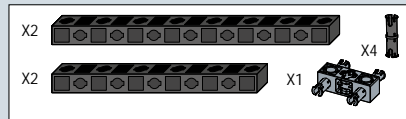
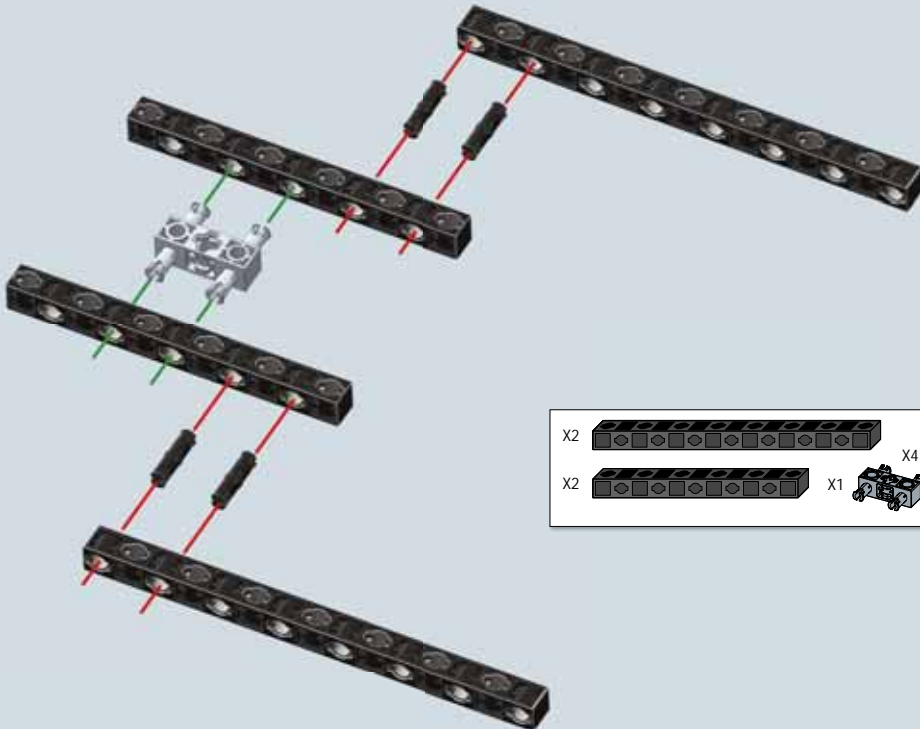

1

2

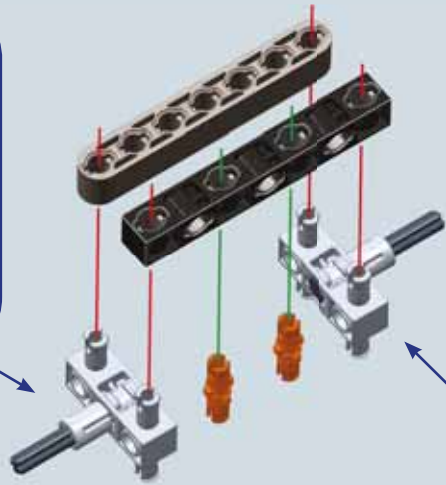

- | | | | |
|----|--|----|--|
| X1 | | X2 | |
| X1 | | X2 | |
| X2 | | X2 | |

3

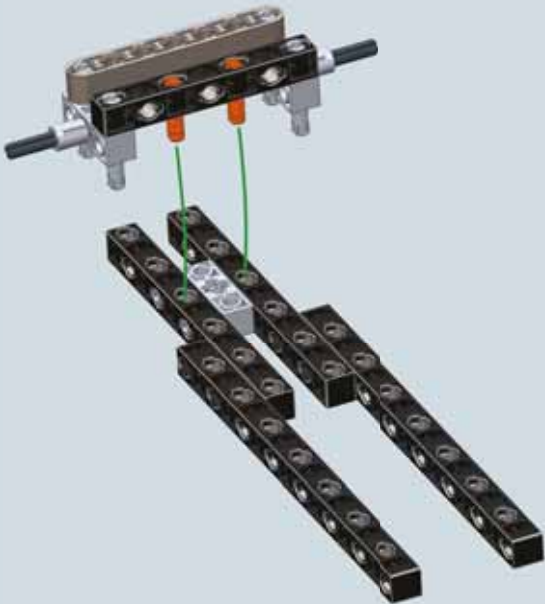

- | | | | | | |
|----|--|----|--|----|--|
| X1 | | X1 | | X1 | |
| X1 | | | | | |

4

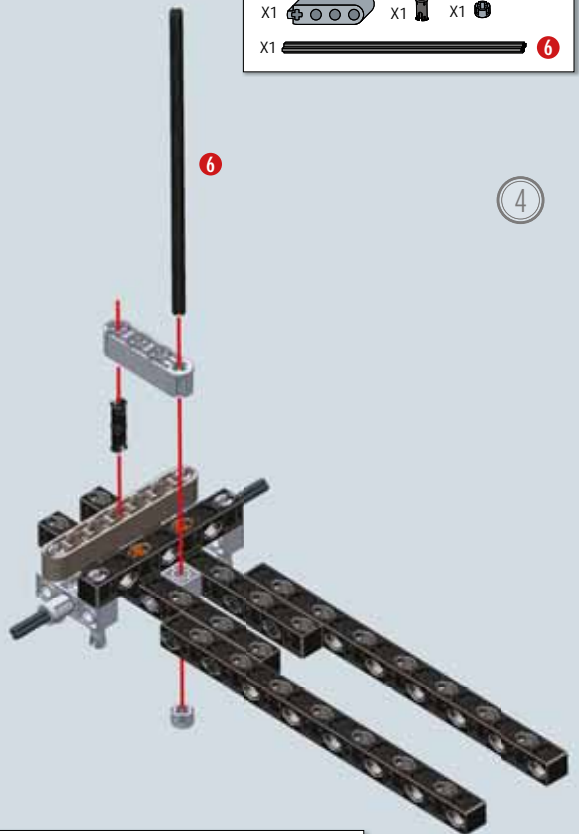

- | | | | | | |
|-----|--|----|--|----|--|
| 1:1 | | X1 | | X1 | |
|-----|--|----|--|----|--|

5

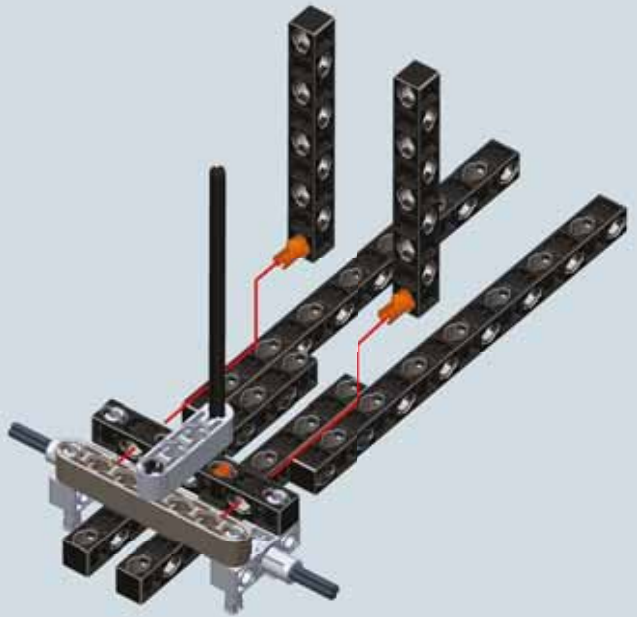
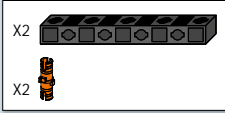

6

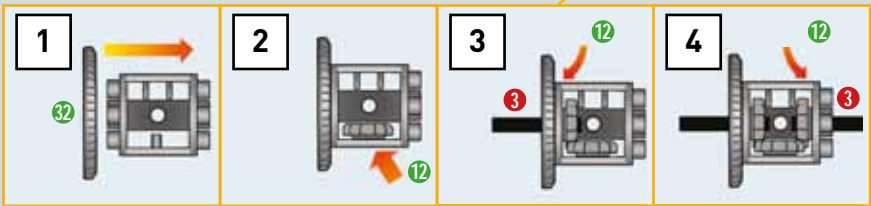
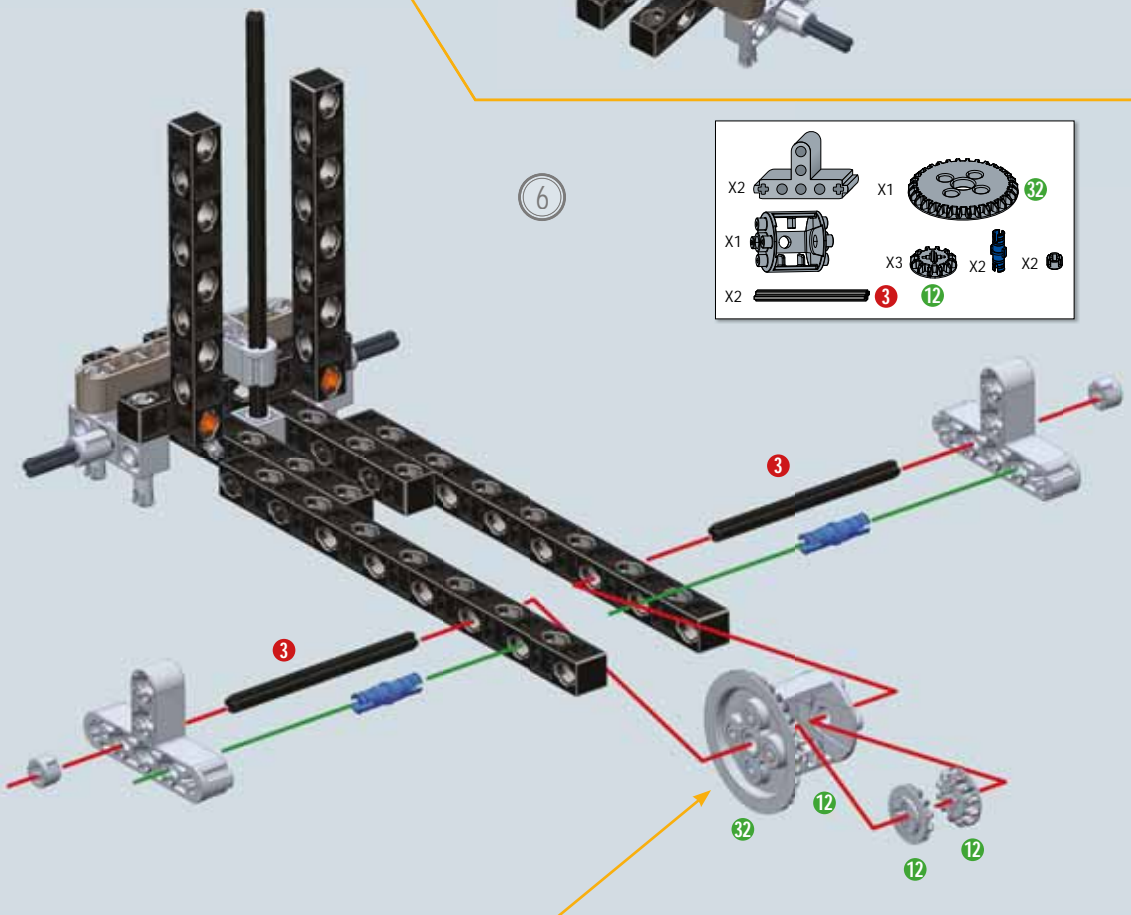
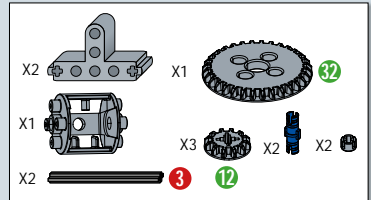

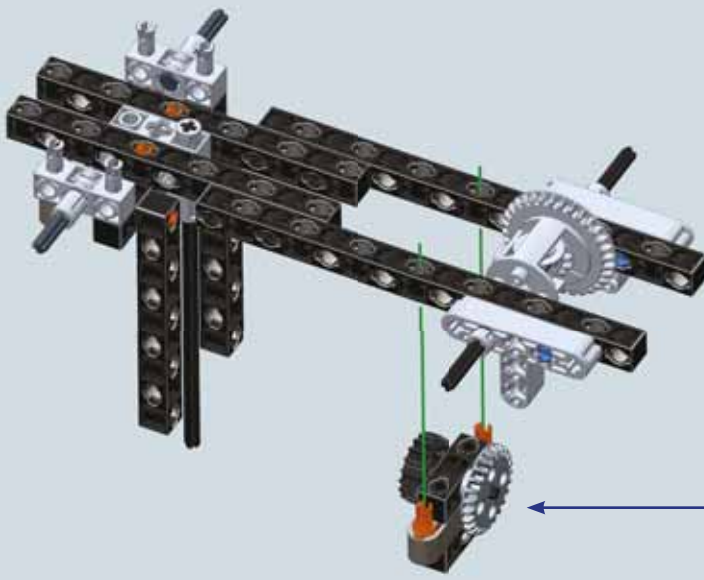

- | | | | | | |
|----|--|---|----|--|----|
| X1 | | 1 | X1 | | 24 |
| X2 | | | X2 | | 18 |
| X1 | | | X2 | | |

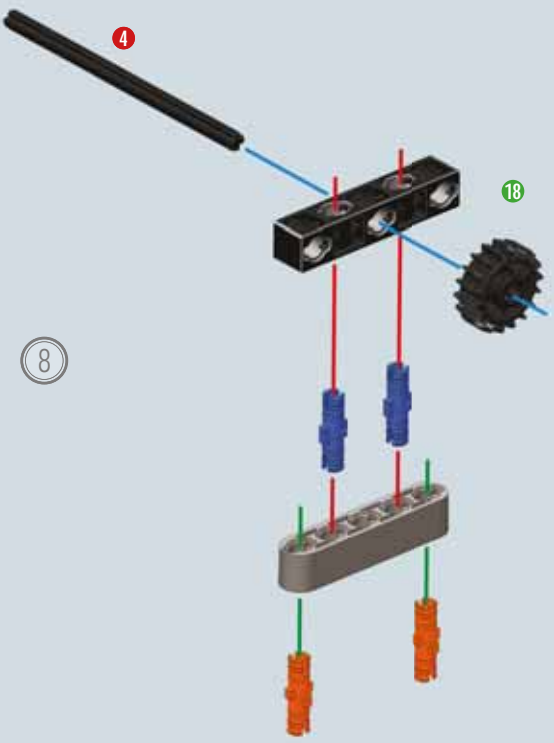
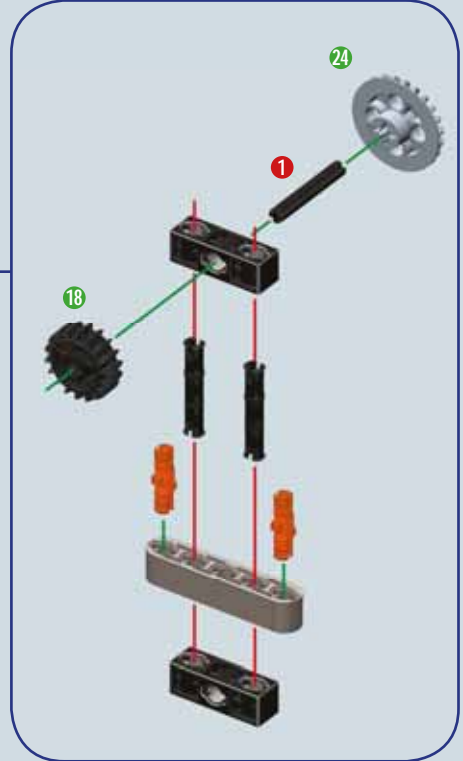

- | | | | | | |
|----|--|----|----|----|--|
| X1 | | X1 | | X2 | |
| X1 | | | 18 | X2 | |
| X1 | | 4 | | X2 | |



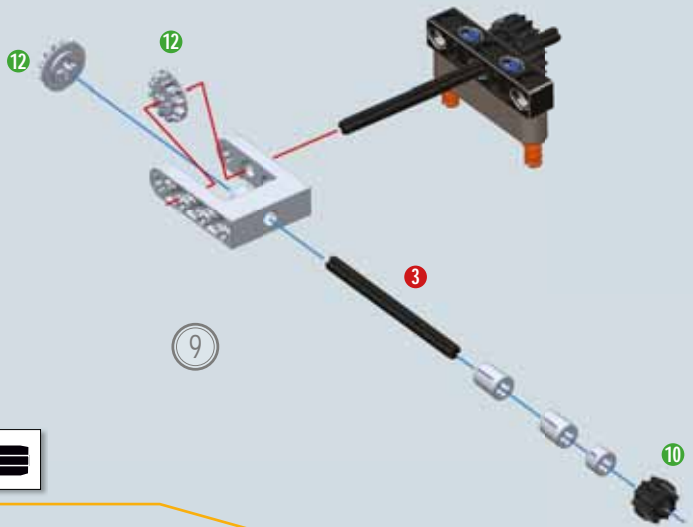
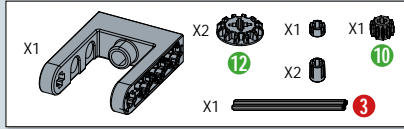
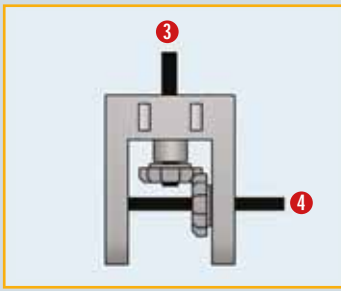

9

10

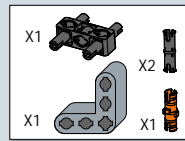
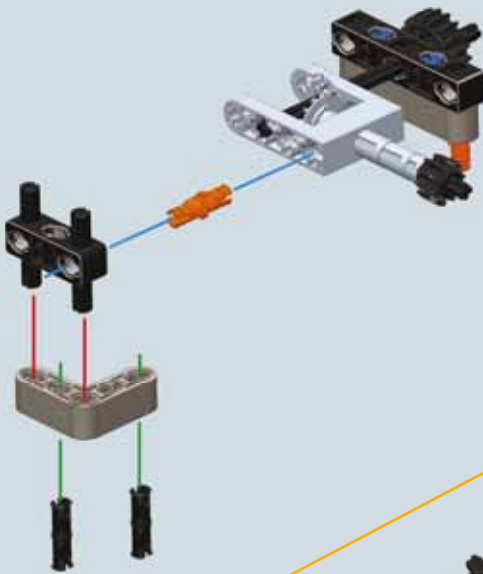

11

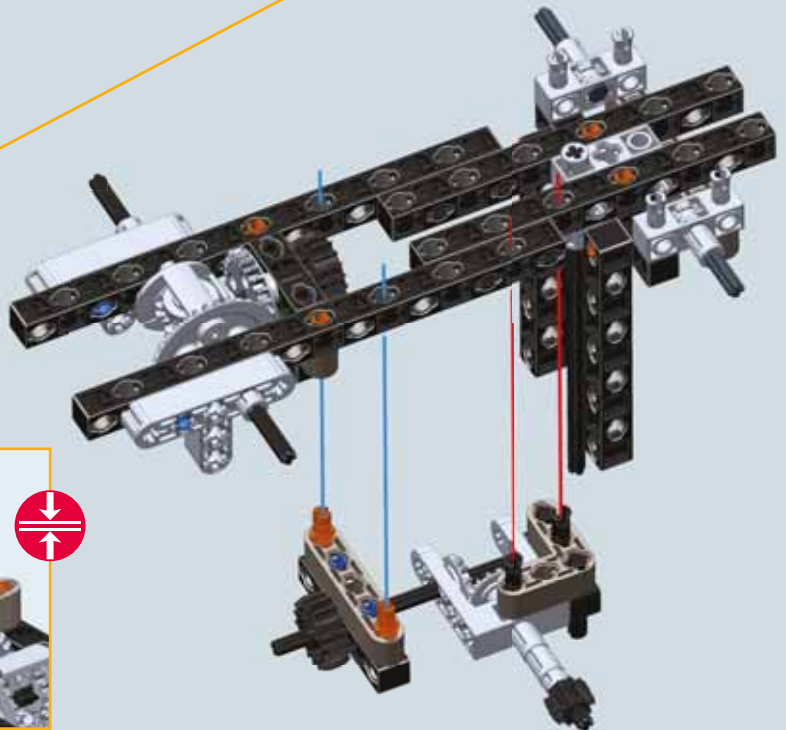

12

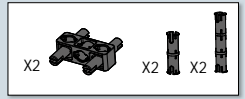
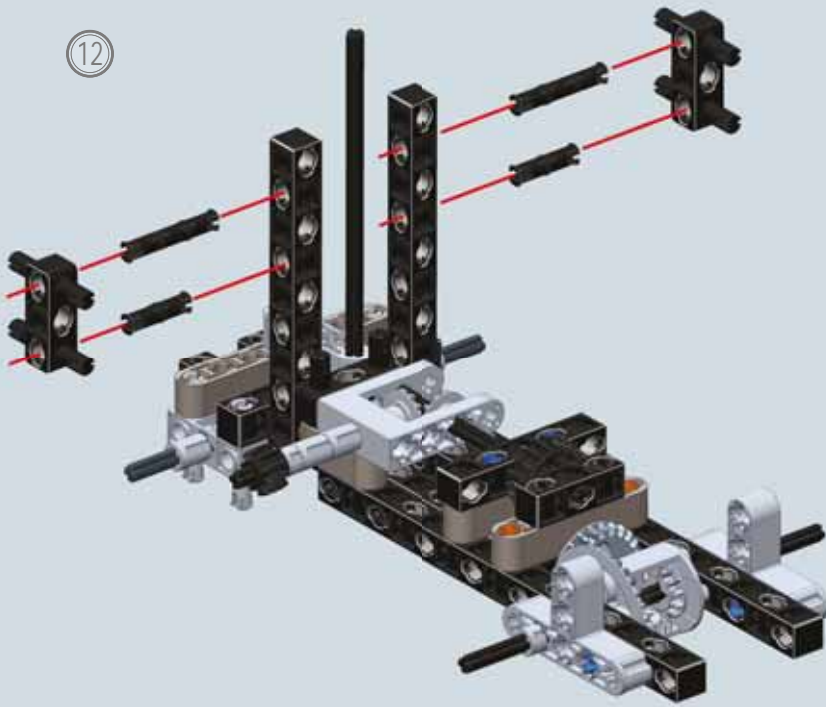

13

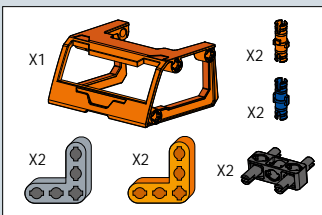
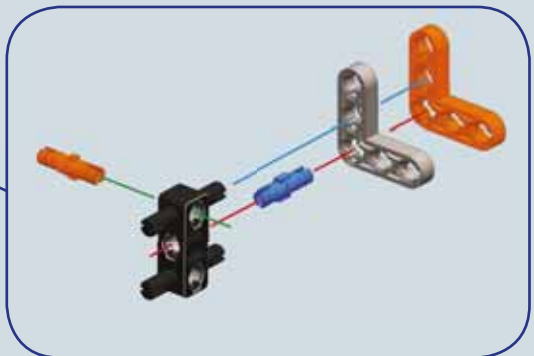
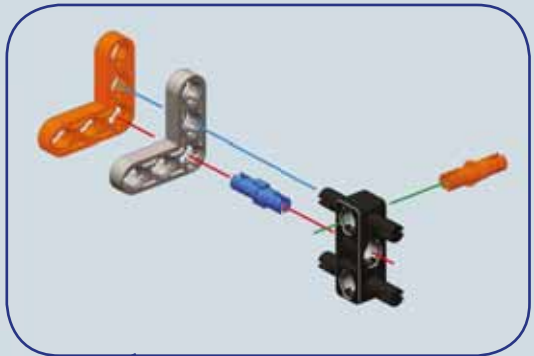
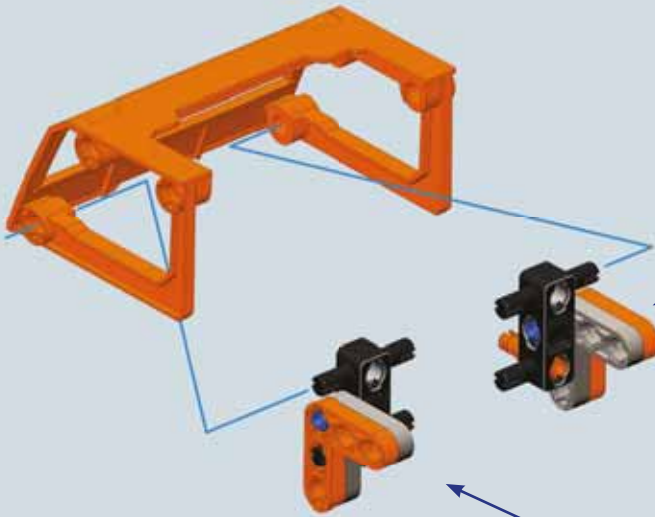

14

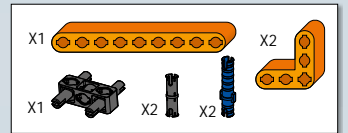
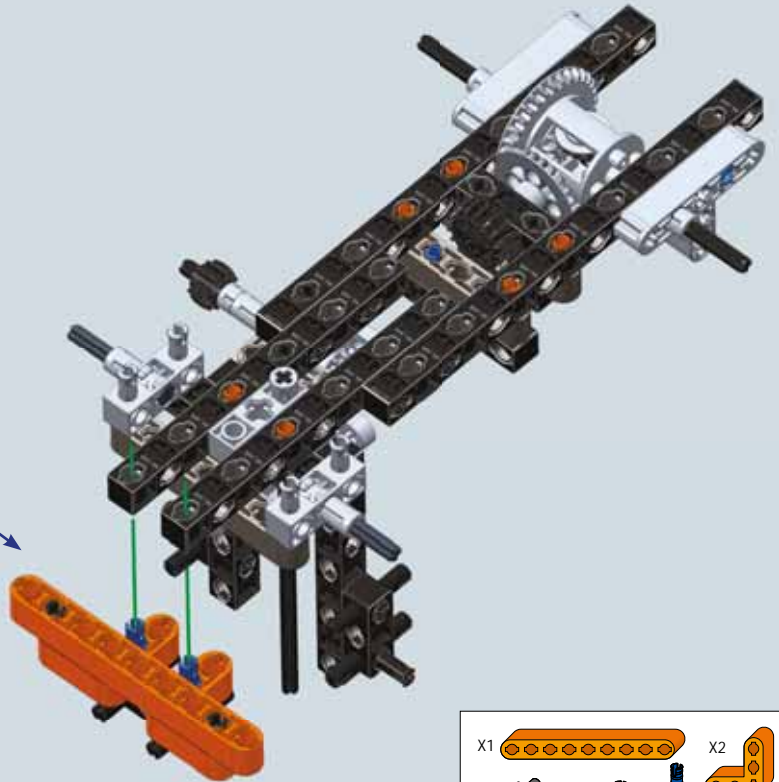
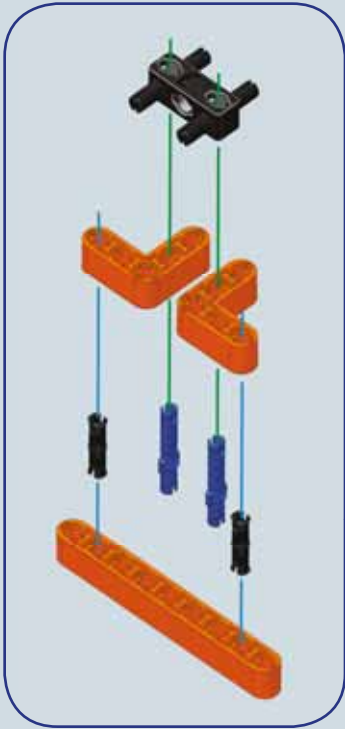

15

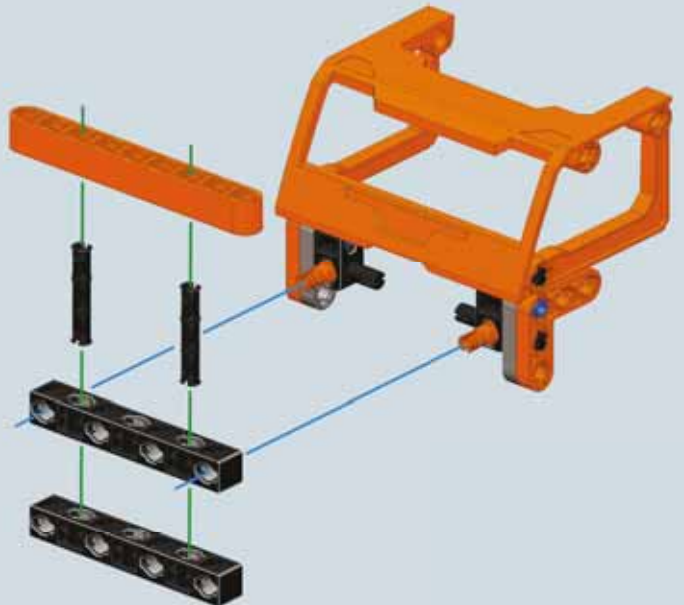
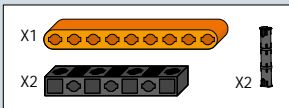

16

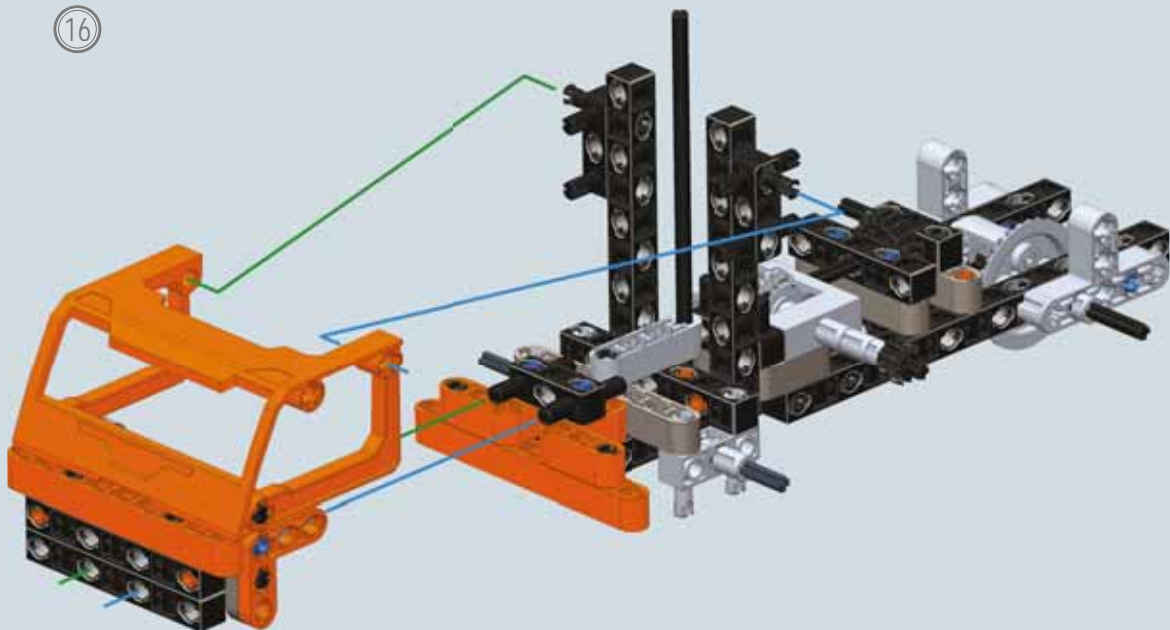

17

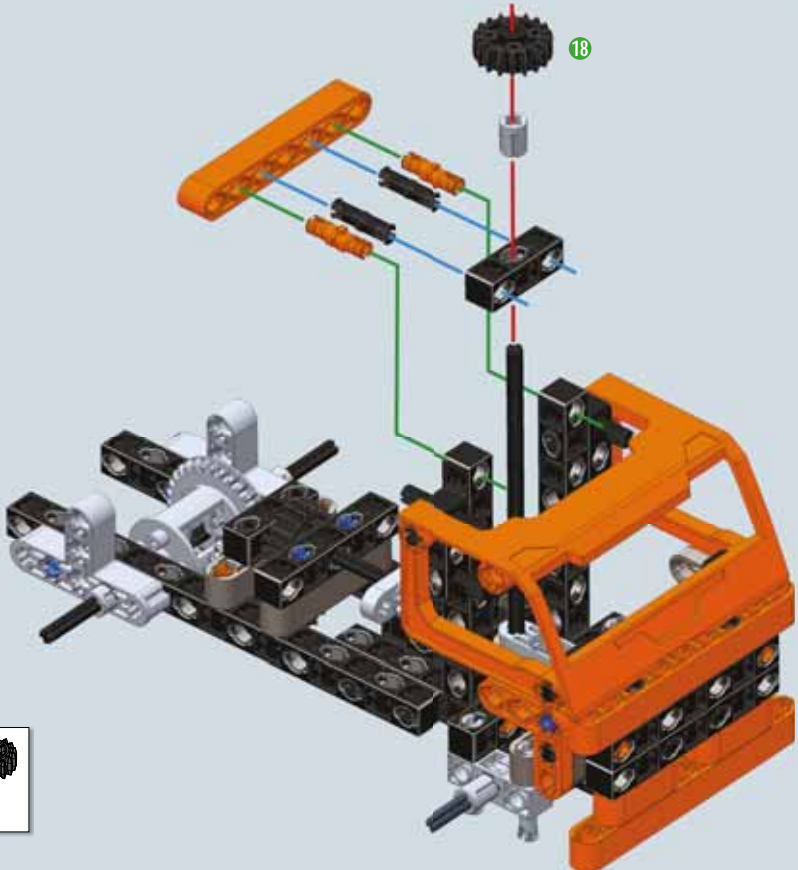

- | | | | |
|----|----|----|----|
| X1 | | X1 | |
| X1 | | X1 | |
| | X1 | | X2 |
| | | X2 | |
| | | | |

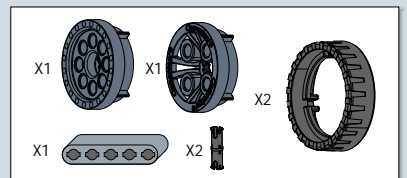
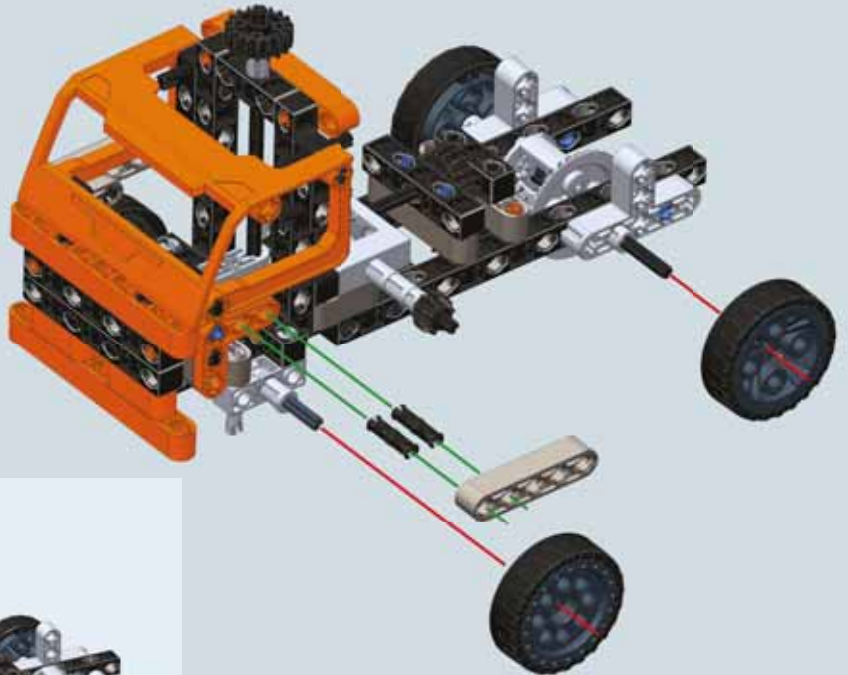
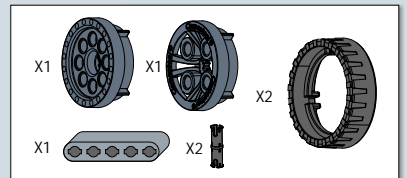
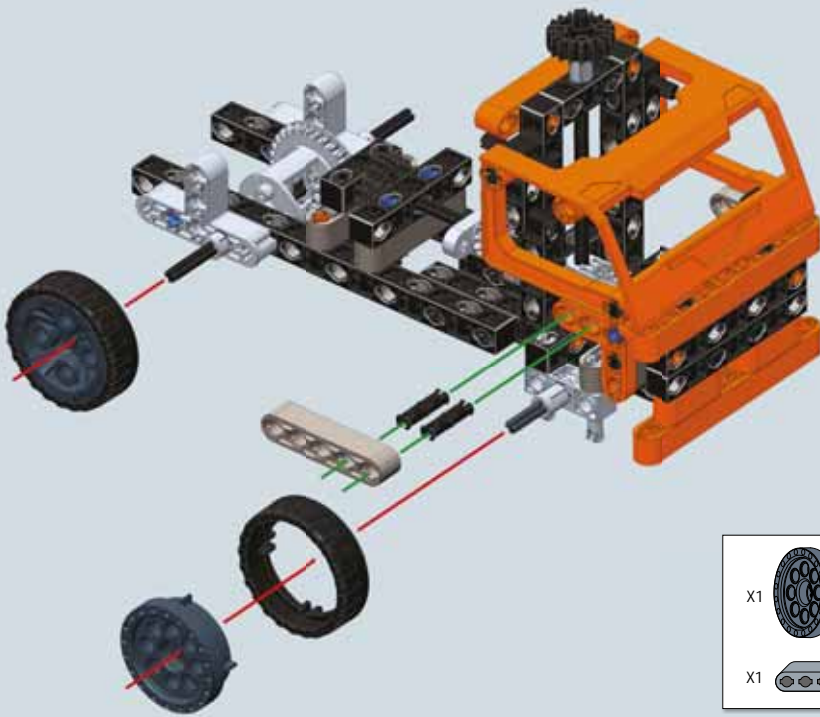

Final assembled model

5 Work equipment: log gripper



Technical facts and curiosities

The hydraulic gripper is a piece of gripping equipment consisting of tongs driven by one or more hydraulic cylinders. The extendible arm connecting it to the truck also exploits the same hydraulic actuators to move. This type of vehicle is used in forestry applications for loading timber for commercial use or even for clearing areas cluttered with logs and branches.

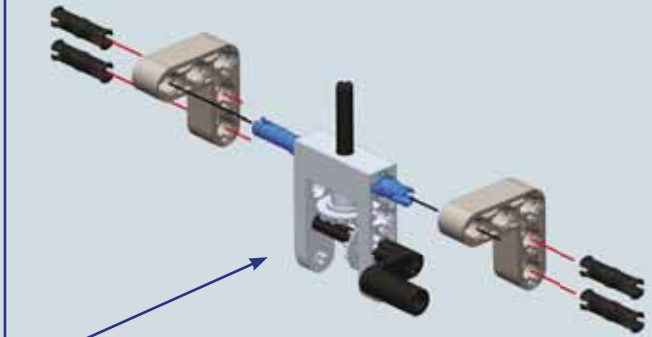
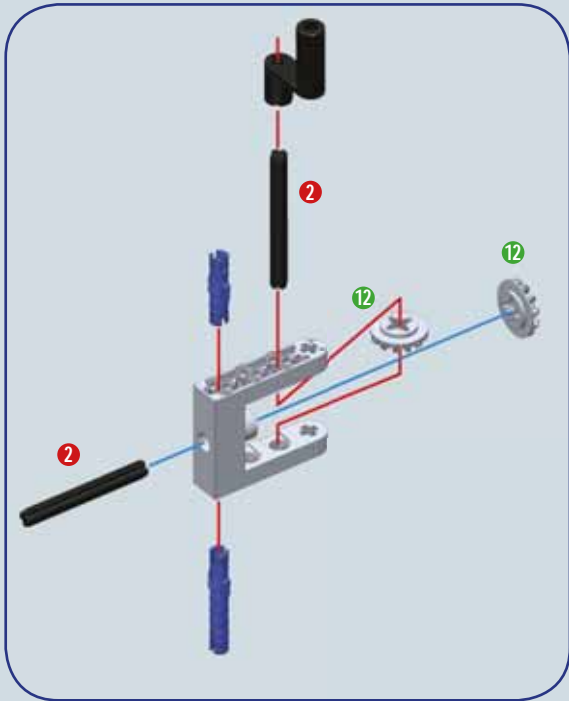

①

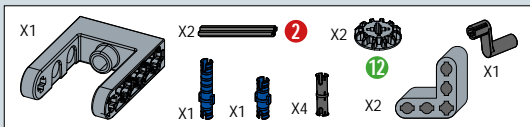
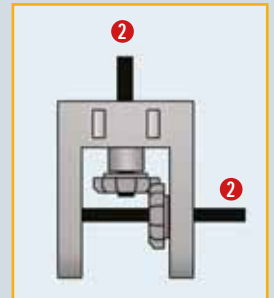

2



Model assembled in Activity 4

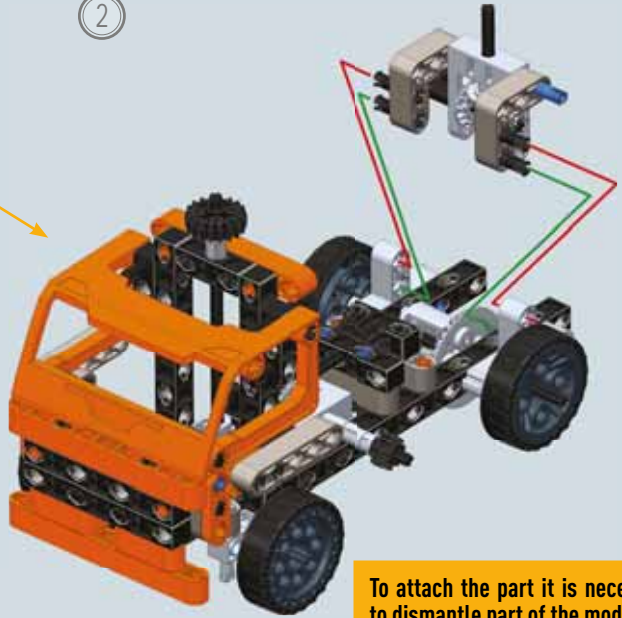

To attach the part it is necessary to dismantle part of the model.

3

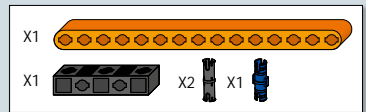
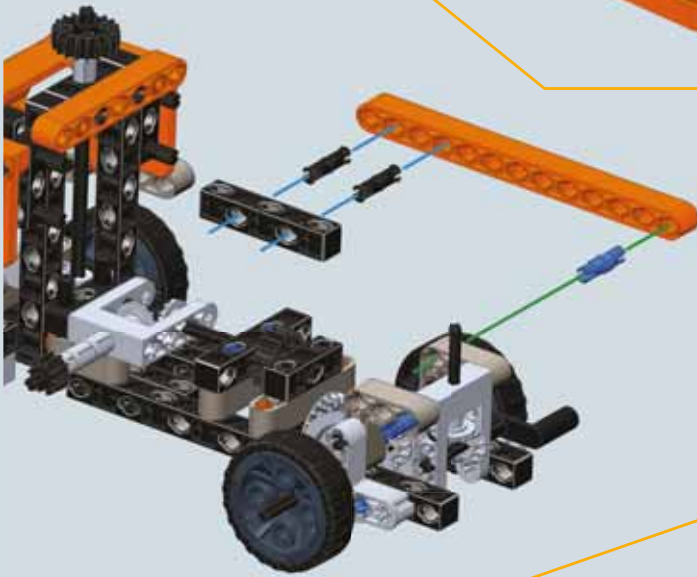

4

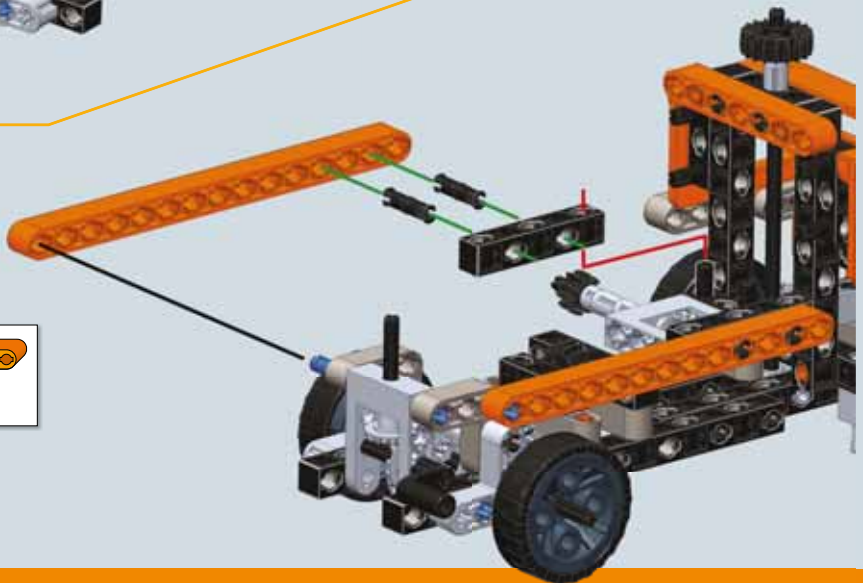
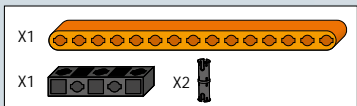

5





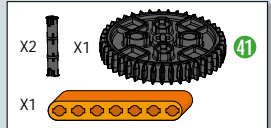
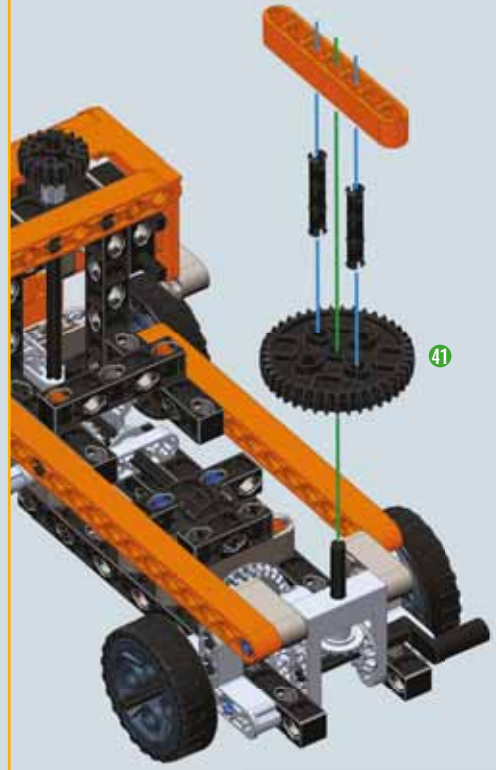

6

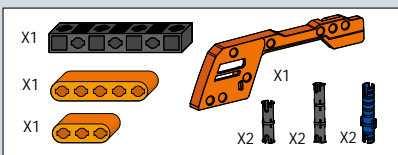
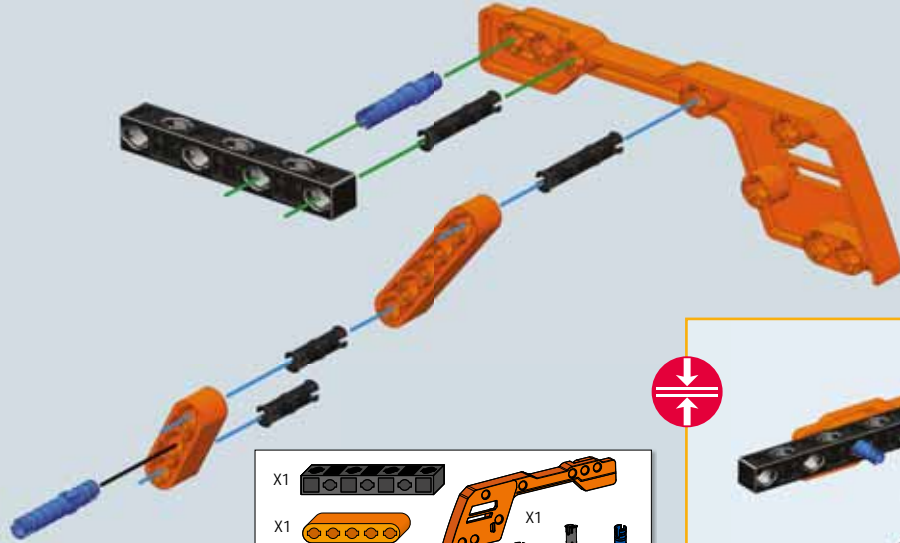

7



8

- X2 
- X1 
- X1 
- X1 

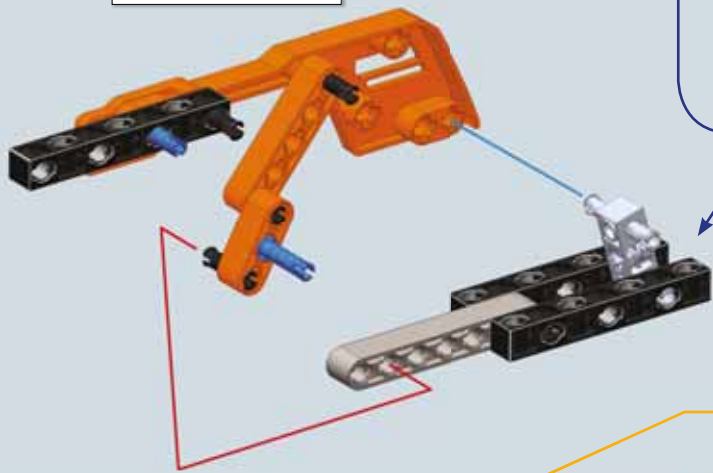
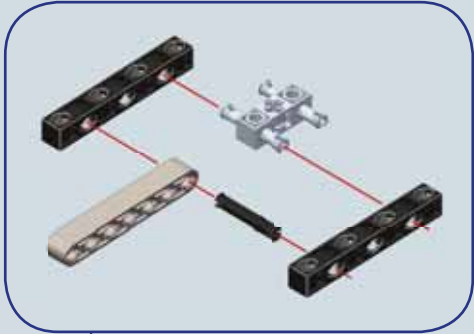

9

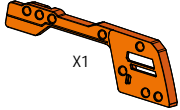
- X1 



10



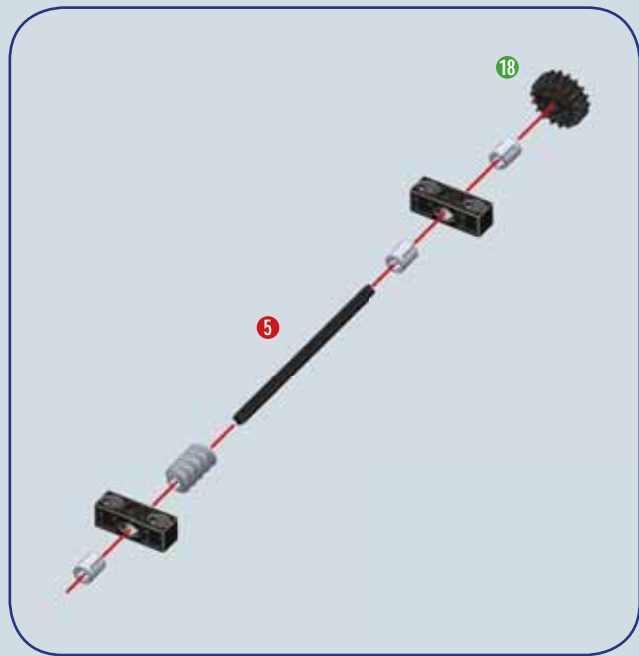

11

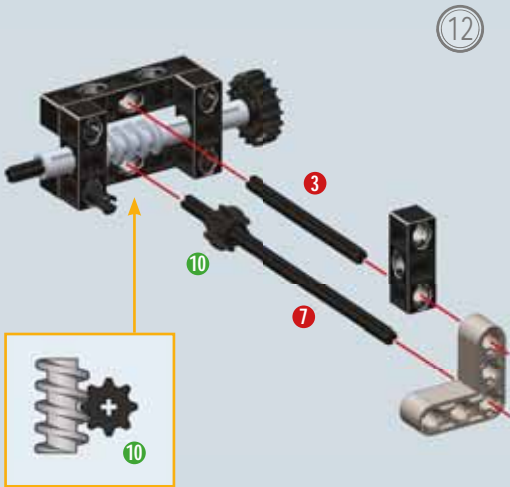
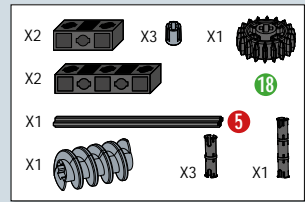

12

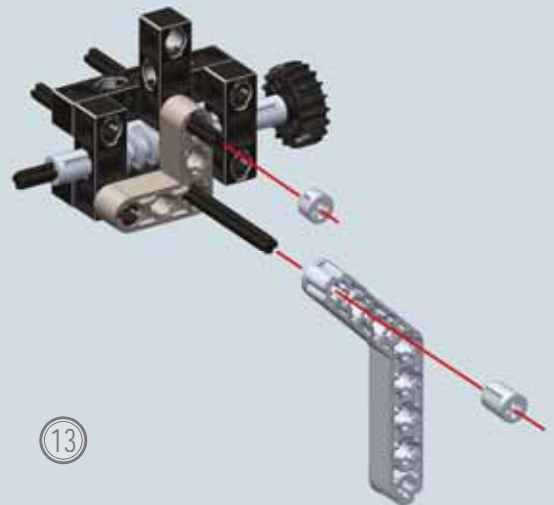
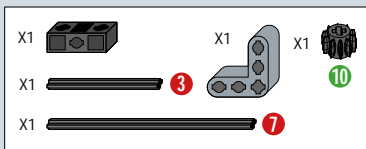

13

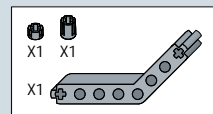

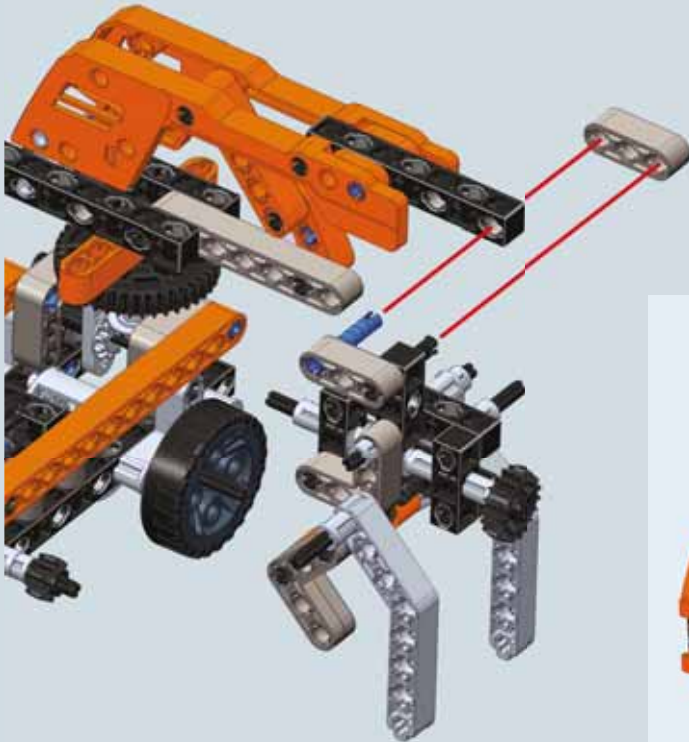
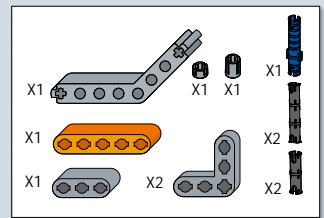
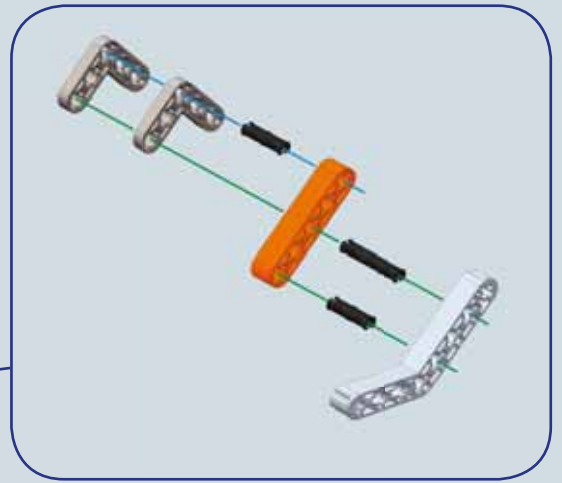
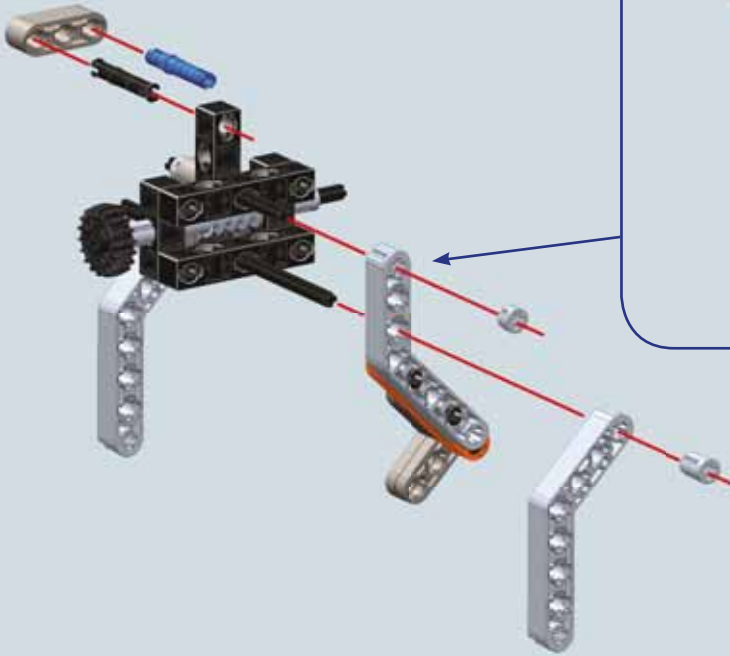

15



Final assembled model

6 Work equipment: the tipper bed



Technical facts and curiosities

The truck with tipper bed, or tipper truck, is also able to autonomously transport goods. It is normally used to carry bulk cargo, such as sand, gravel or waste. Also in this case, the tipper bed is driven by hydraulic pistons.



- X1
- X1
- X1
- X1
- X1
- X1
- X2
- X2
- X2

1

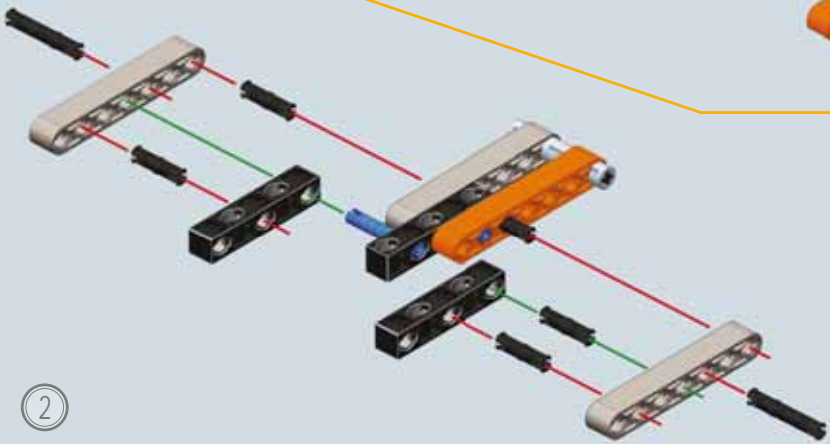
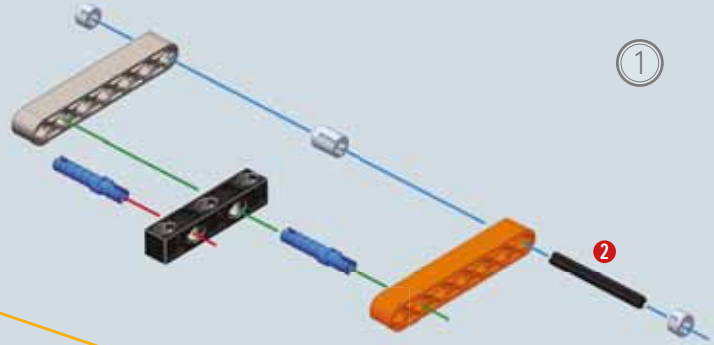

2

- X2
- X2
- X2
- X5

- X2
- X2
- X2

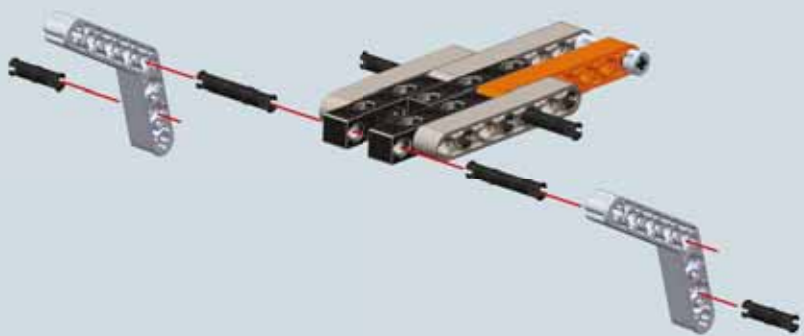

3

- 1:1

5

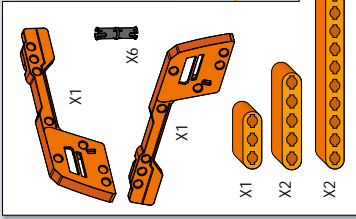

7

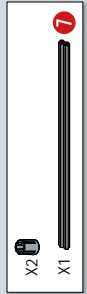

4

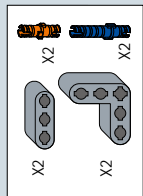
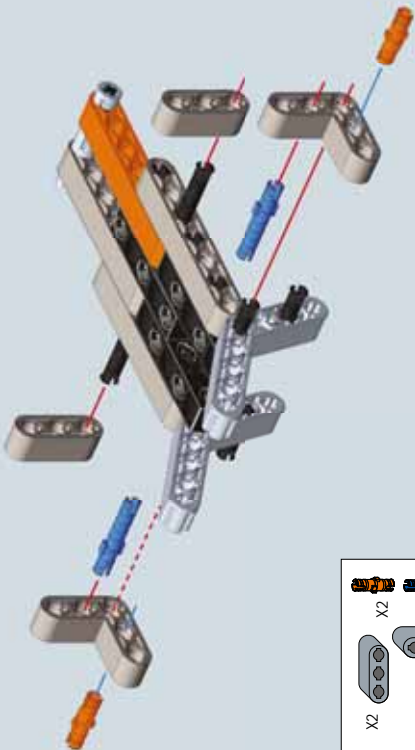

6

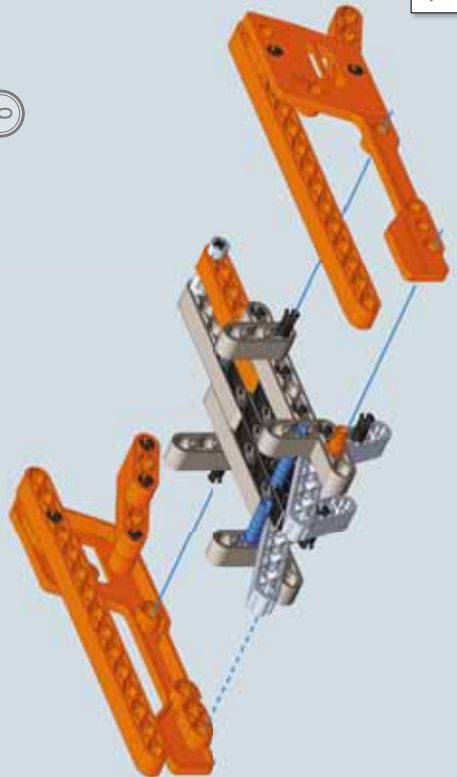

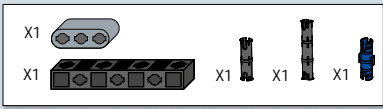

8

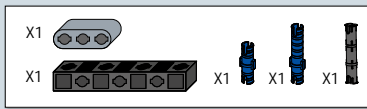
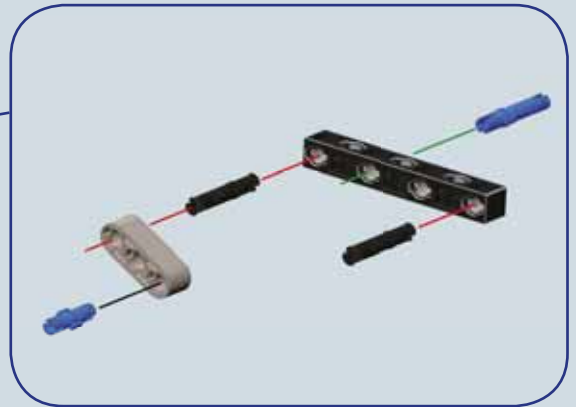
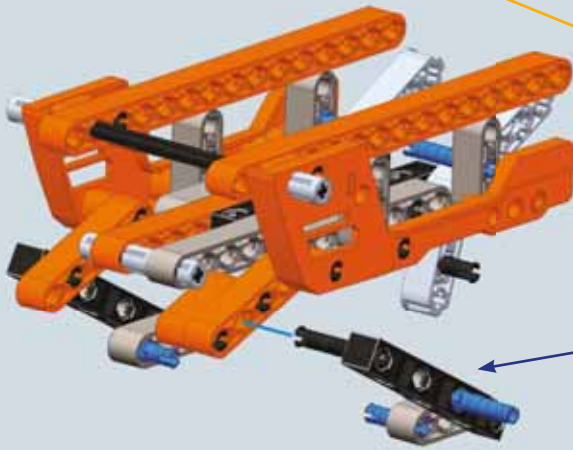
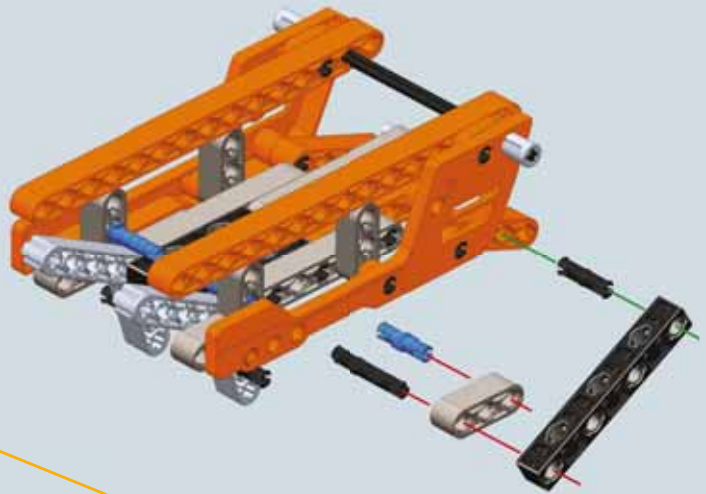

9

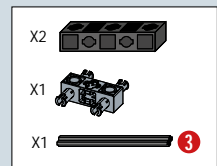
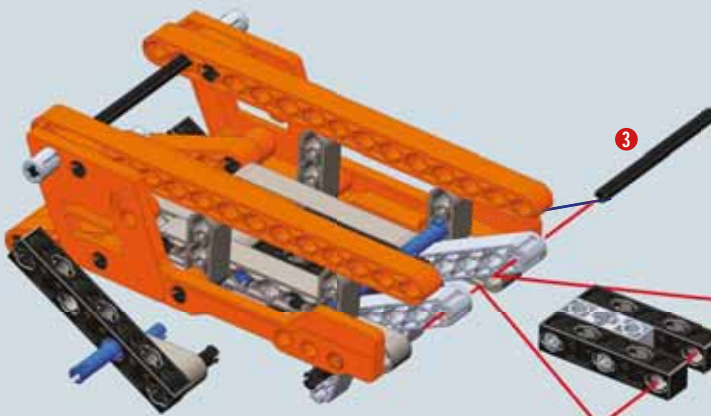

10



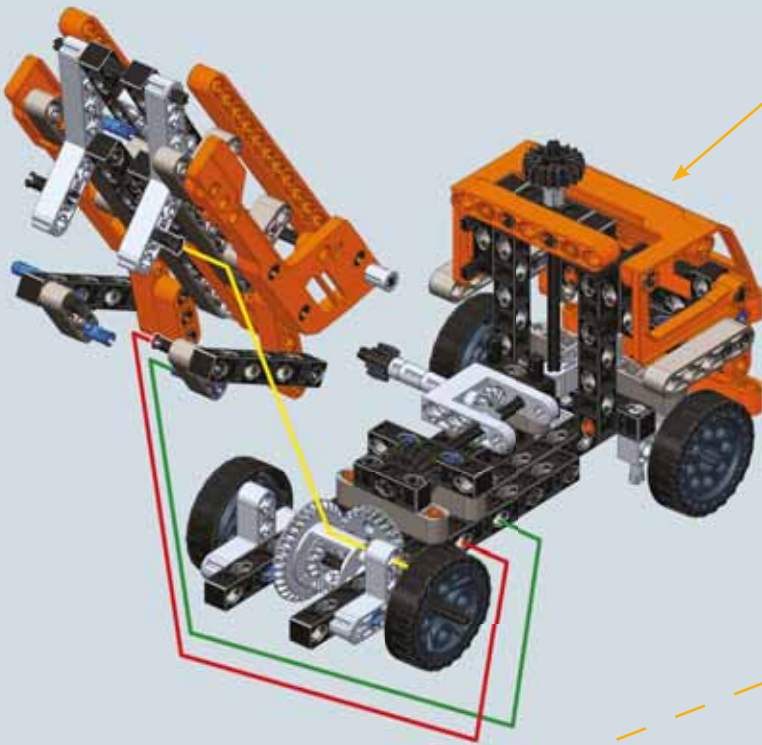

Model assembled in Activity 4

11

To attach the part it is necessary to dismantle part of the model.

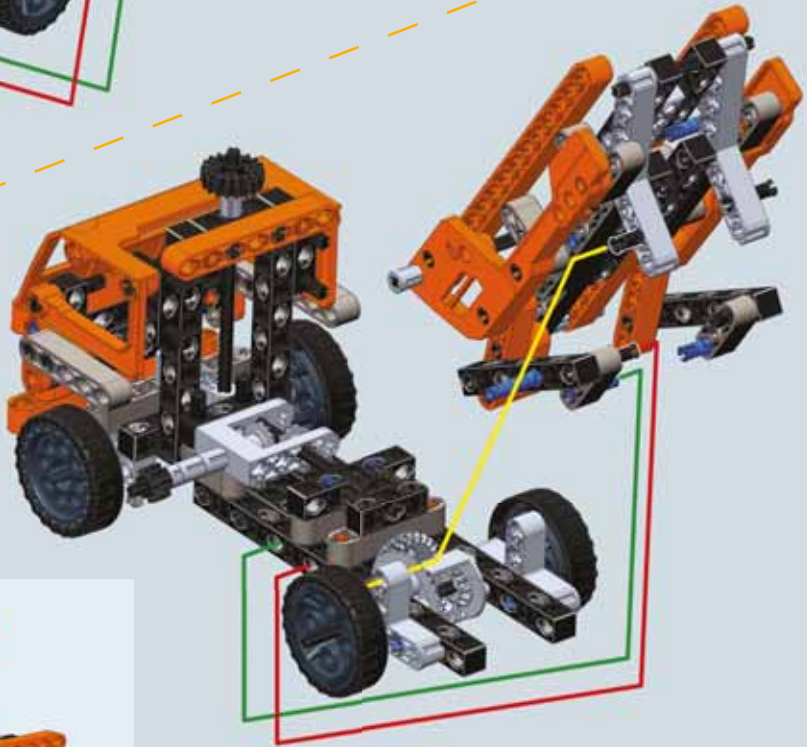

Final assembled model

7 Work equipment: the tow truck



1

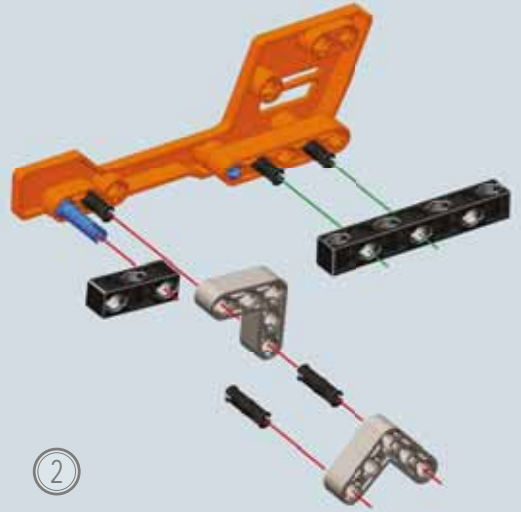
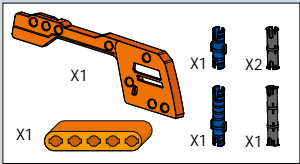
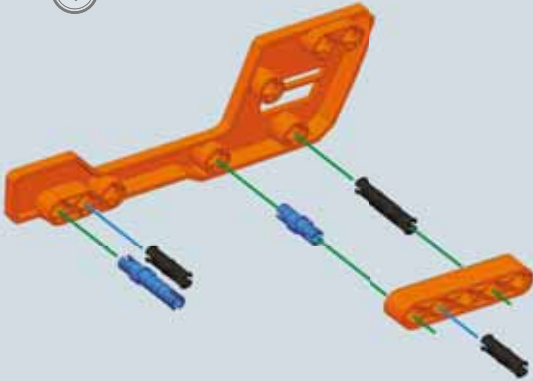

2

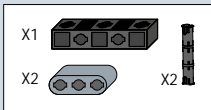
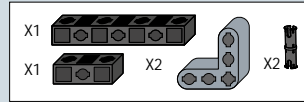

3



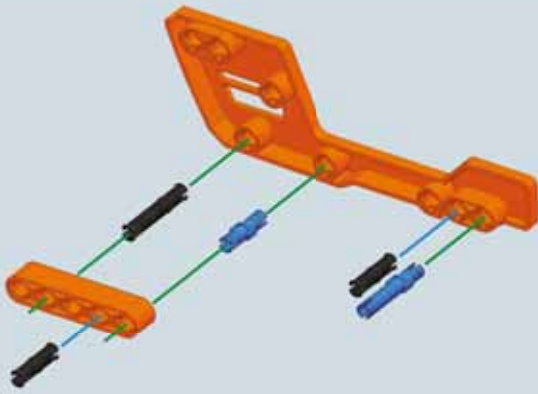

4

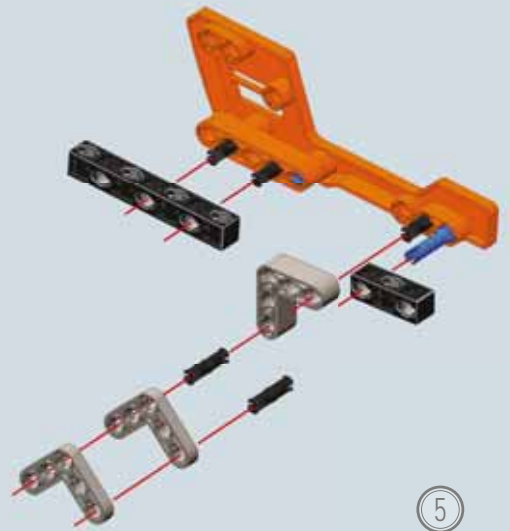
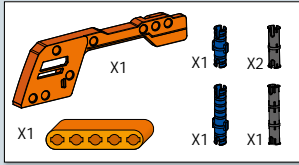

5

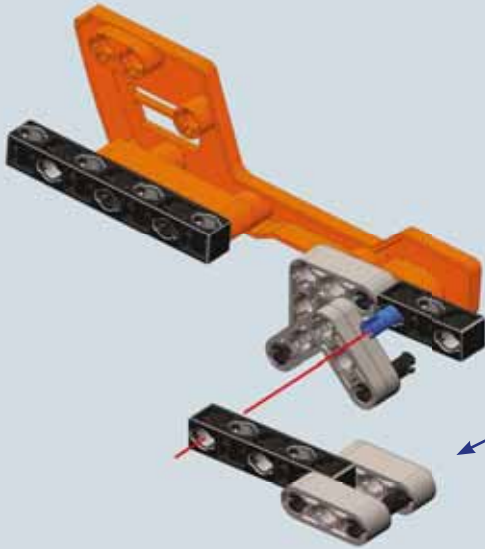
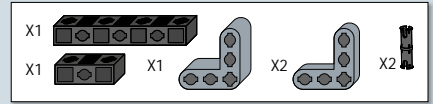

6

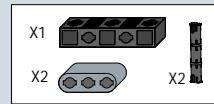
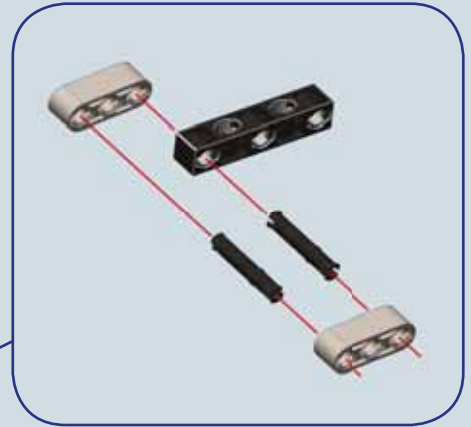

Technical facts and curiosities

The tow truck is a road recovery vehicle designed to assist other engine-powered vehicles in a technical mishap and transfer them from one place to another. In most cases, it is used to recover vehicles that have gone off the road in poorly accessible areas, due to an accident.

7

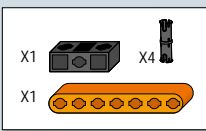
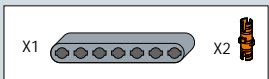

8

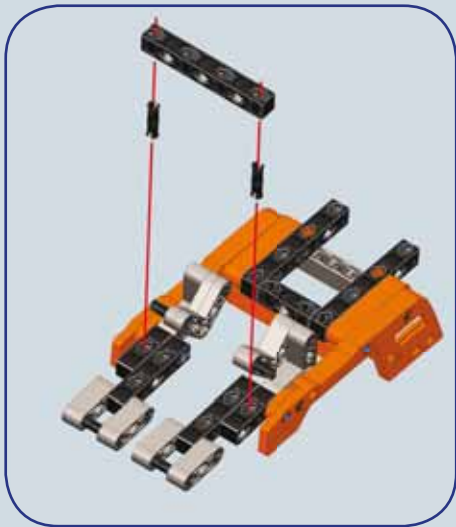

To attach the part it is necessary to dismantle part of the model.

9

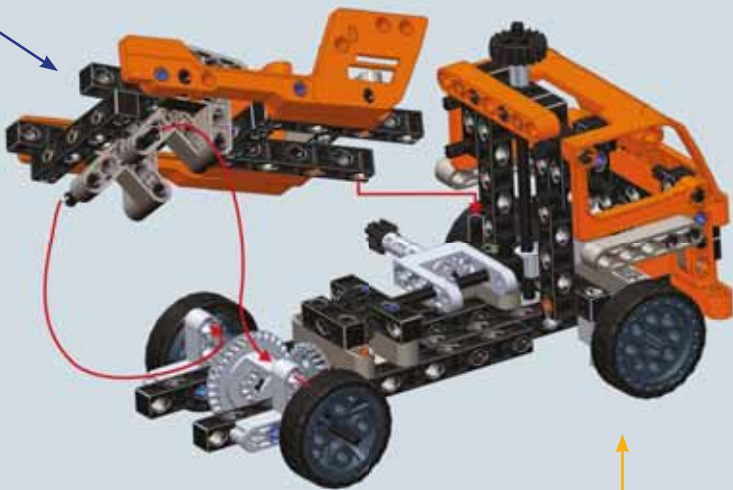

Final assembled model



Model assembled in Activity 4

8 Work equipment: the crane arm



1

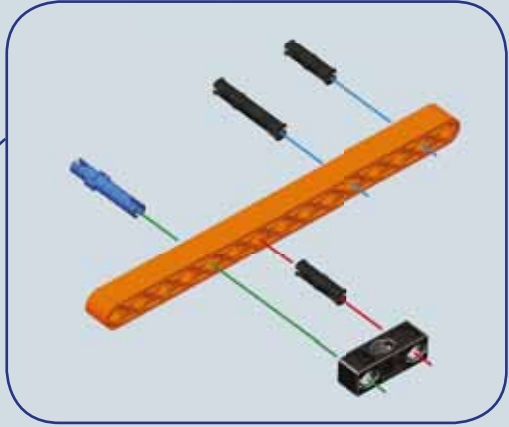
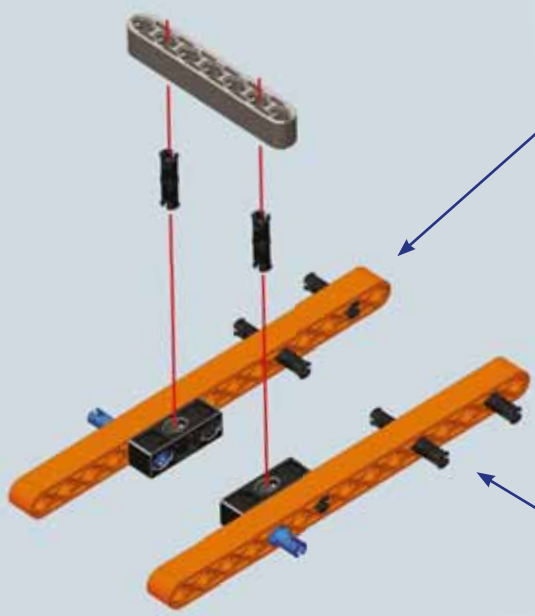

- X2
- X2
- X2
- X6
- X2
- X1

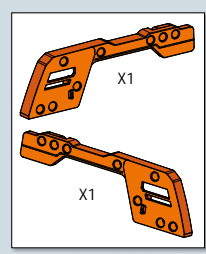
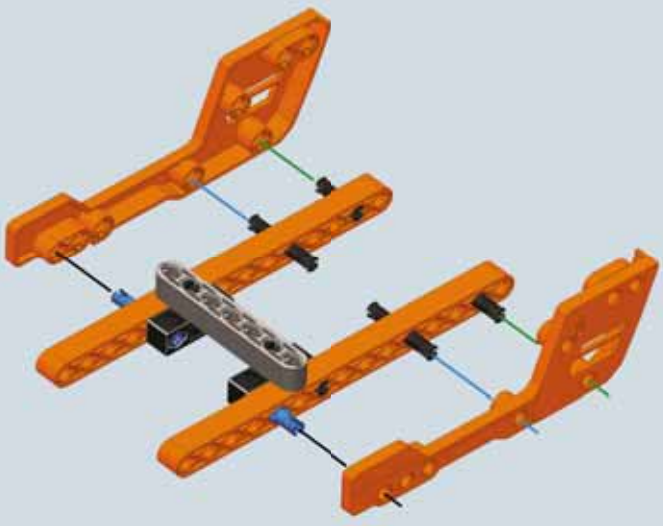

2



Model assembled in Activity 4

3

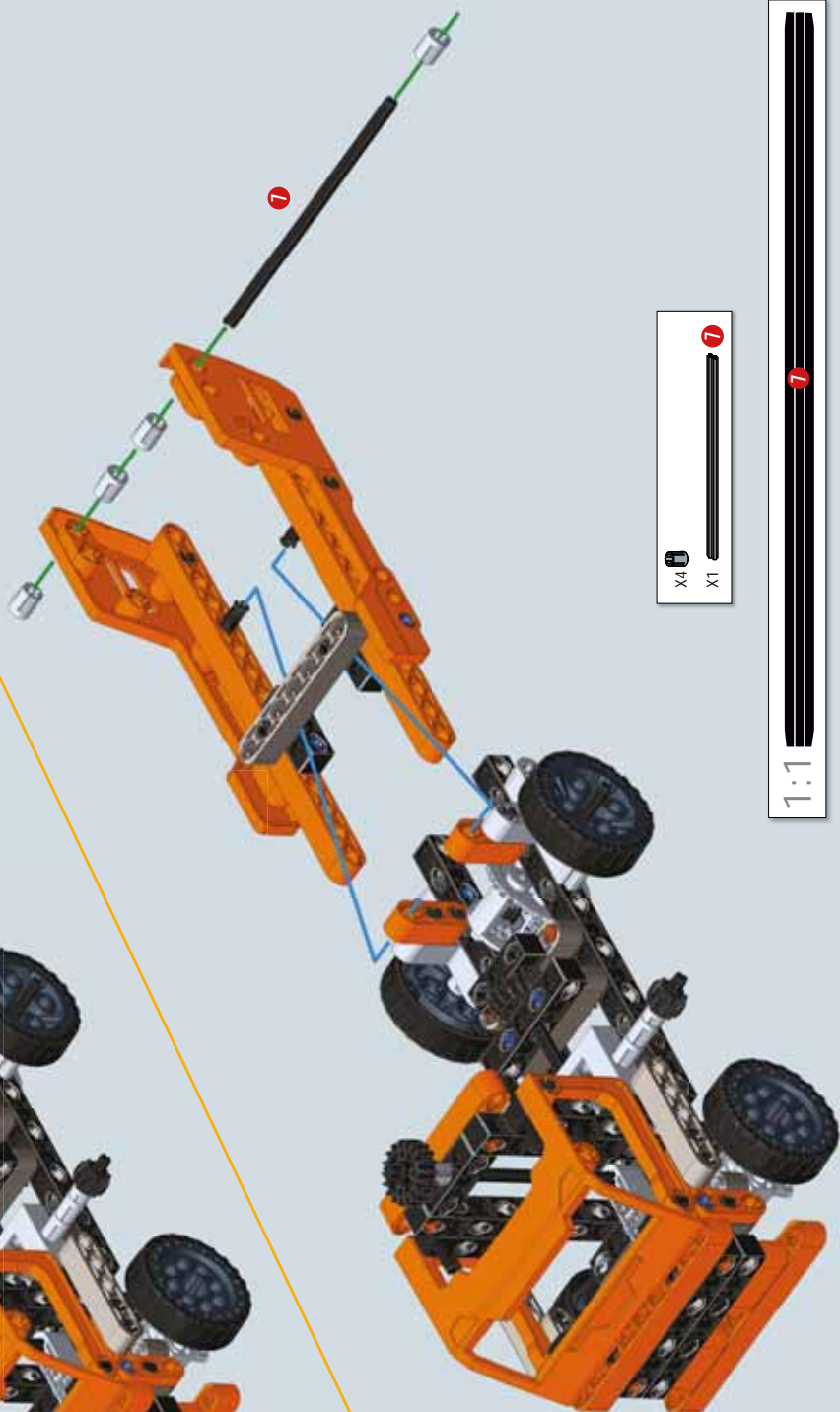
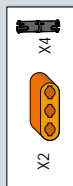
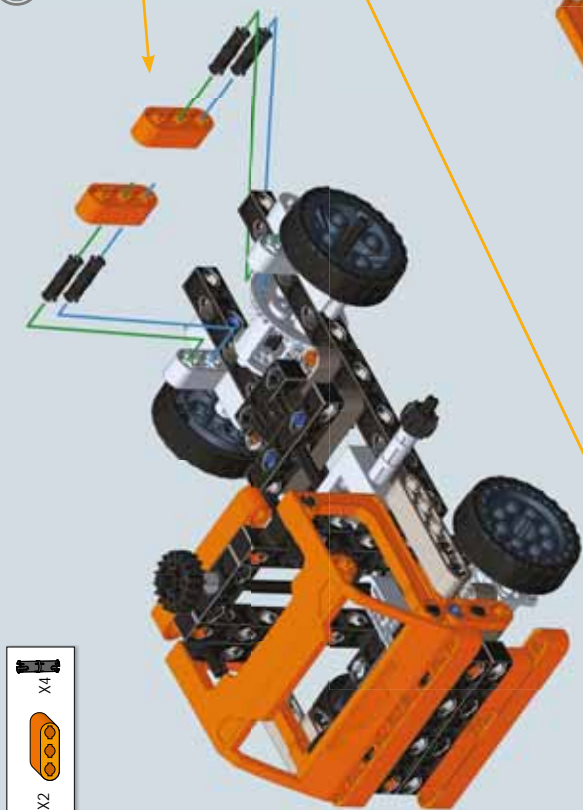

4



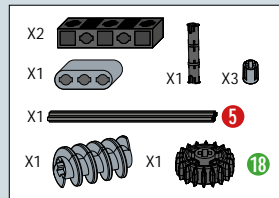

5

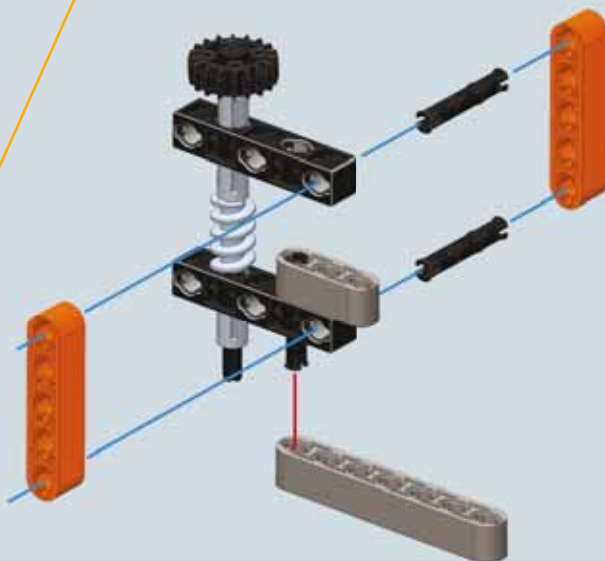

6

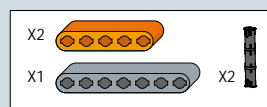

7

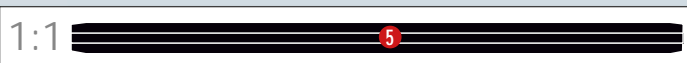
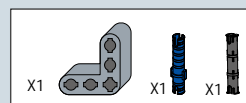
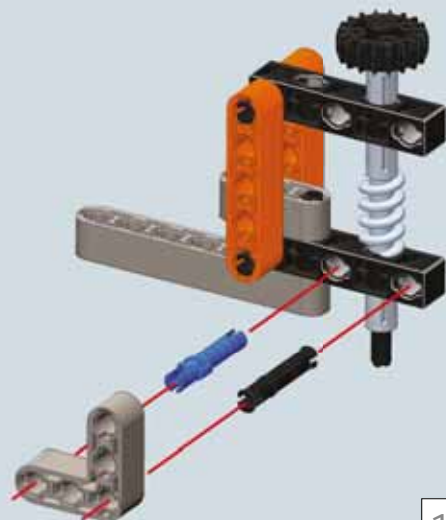

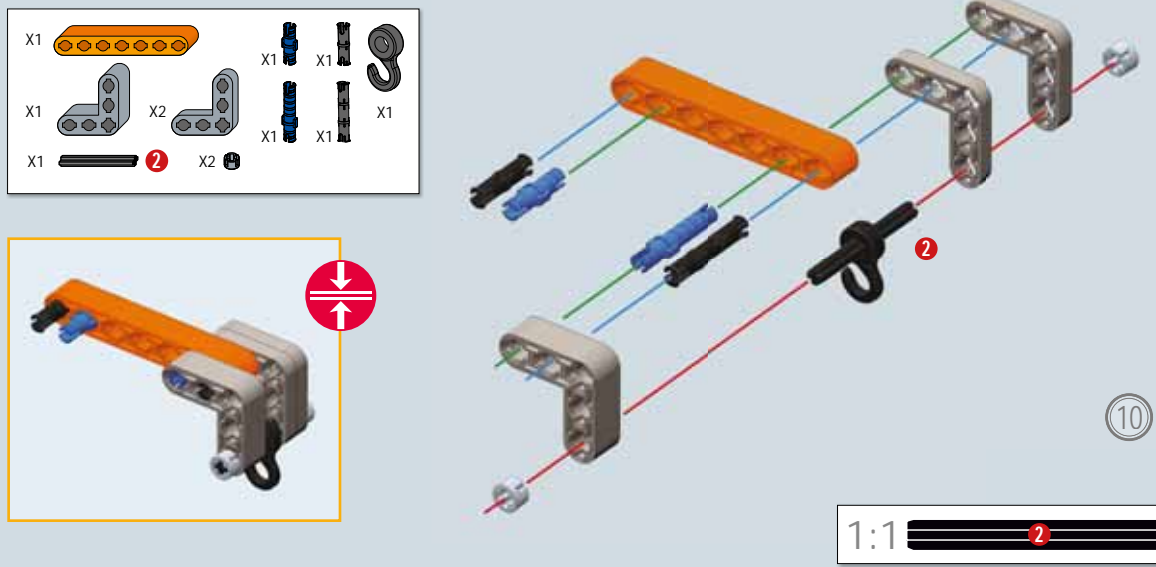
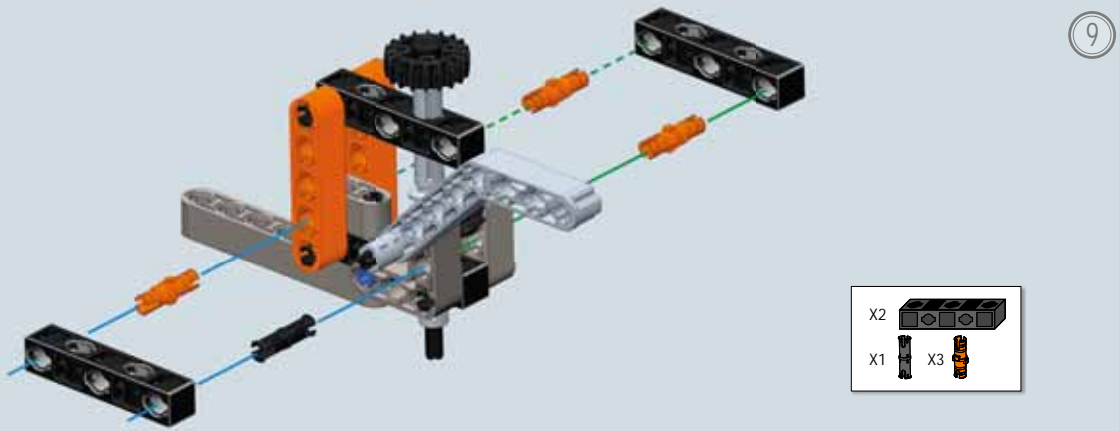
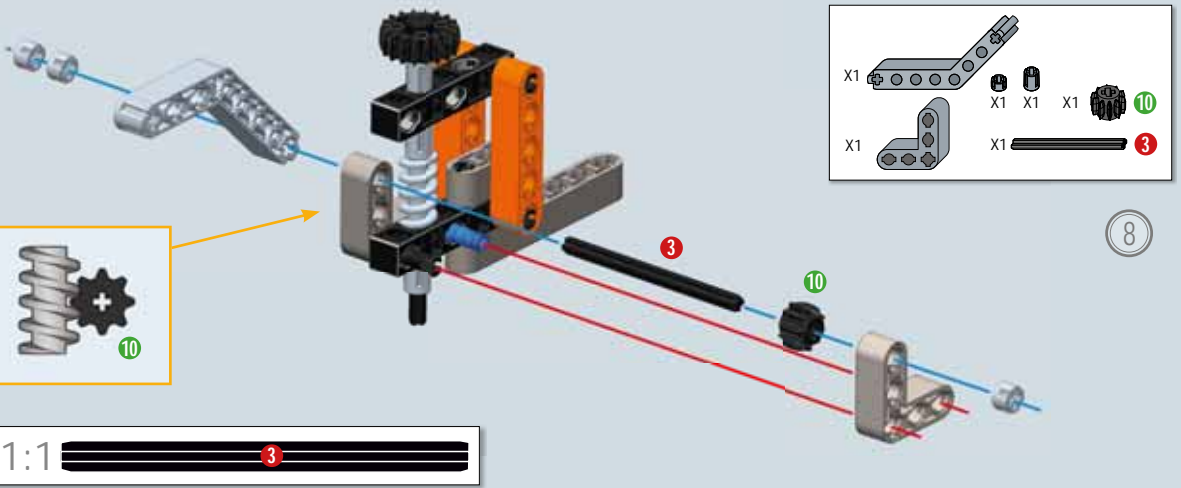

11

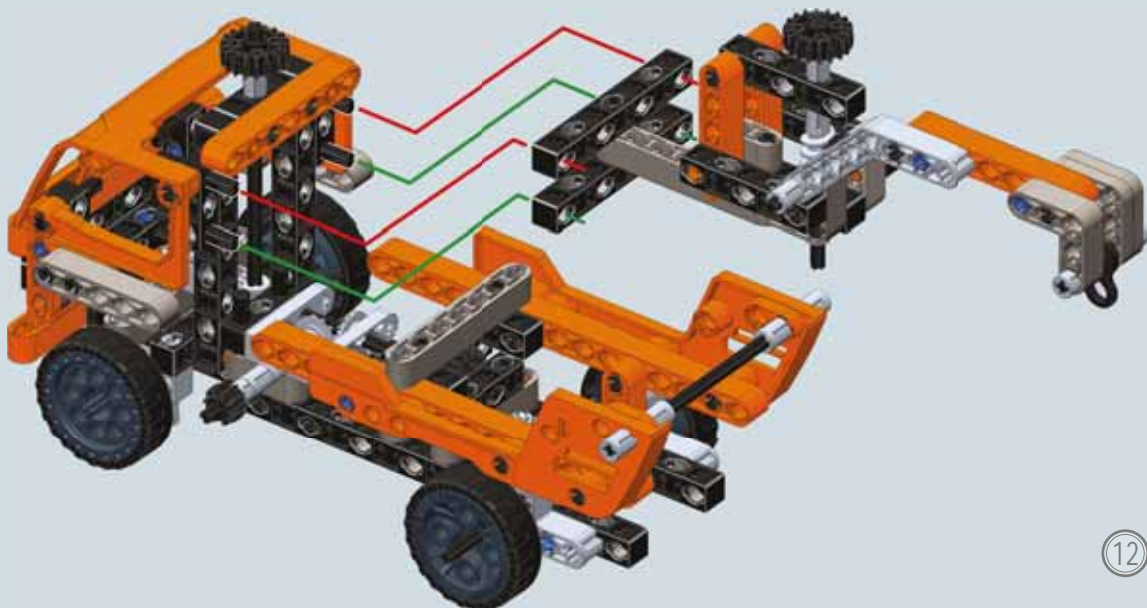
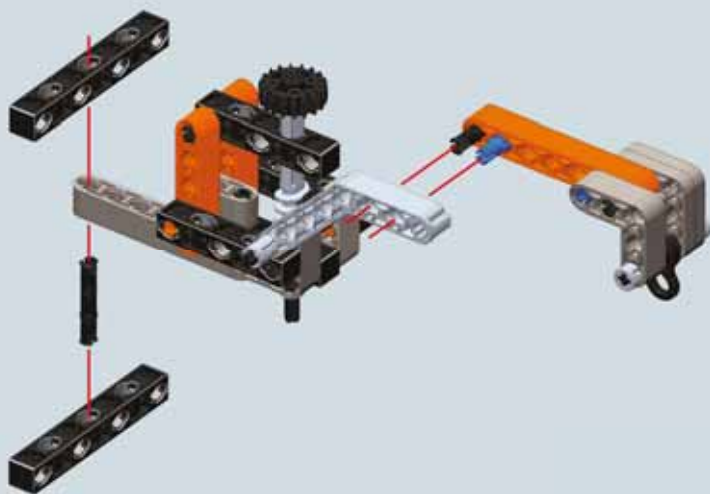

12

Final assembled model

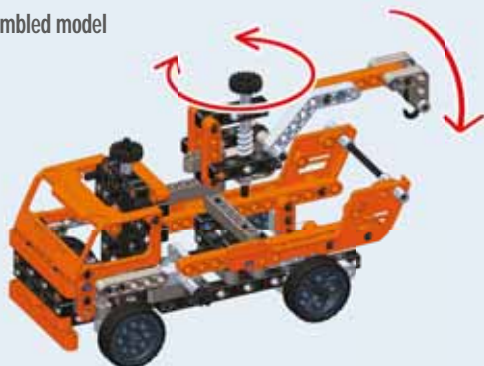



Technical facts and curiosities

The term "snow plough" does not actually refer to a vehicle, but rather to the device mounted on a vehicle and used to remove snow and ice from the road surface.

The distinctive tool of the snow plough is a shaped steel slab which can be mounted on lorries but also on normal off-road vehicles and even on trains, to remove snow from the tracks.

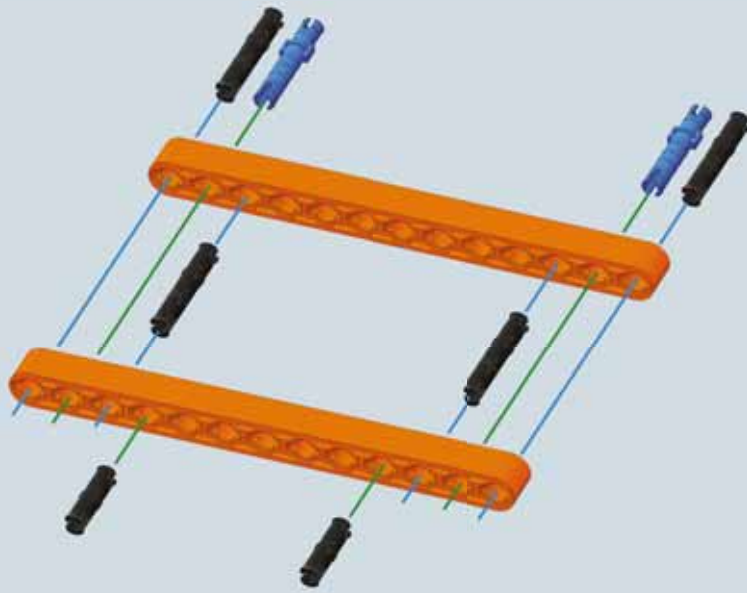

1

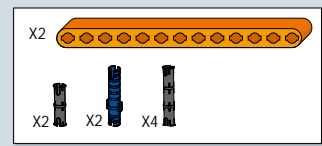

2

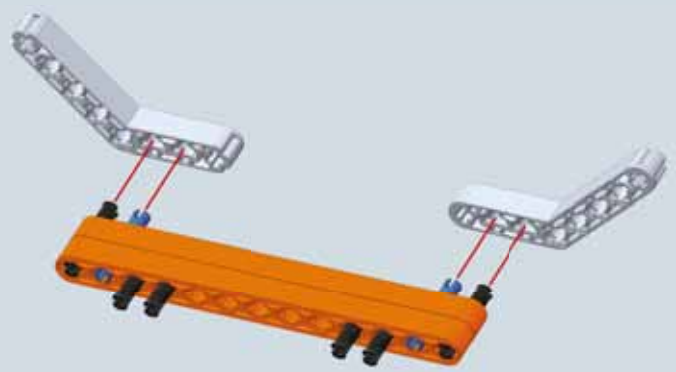
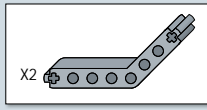

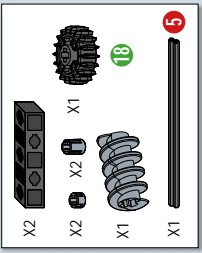

4

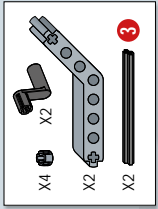
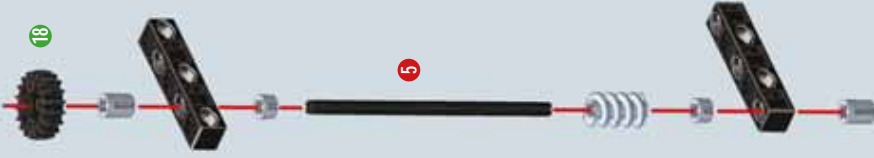

3

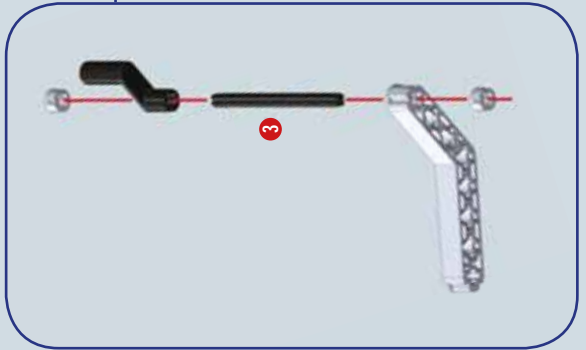
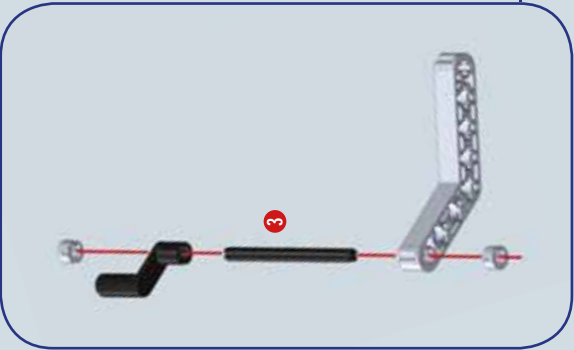
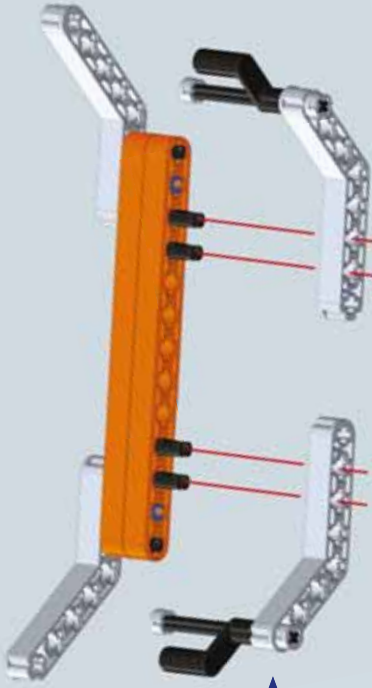

5

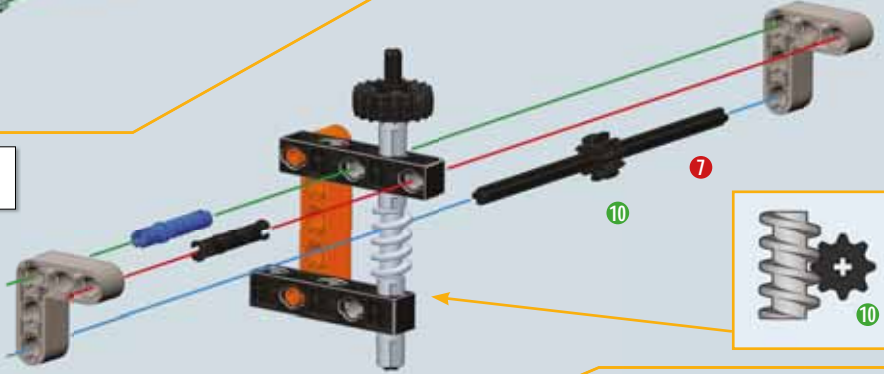
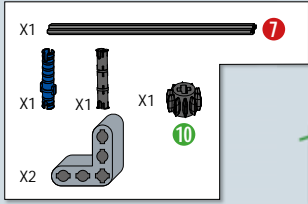
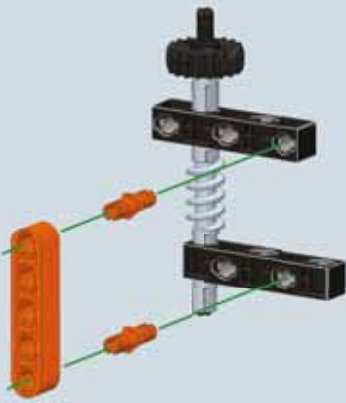
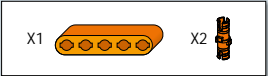

6



7

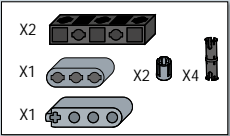
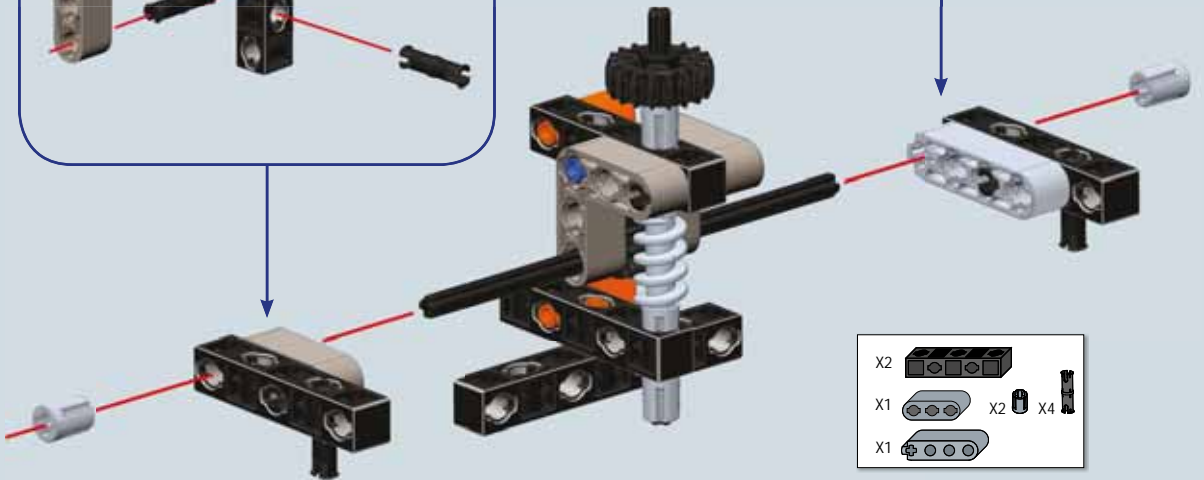

9

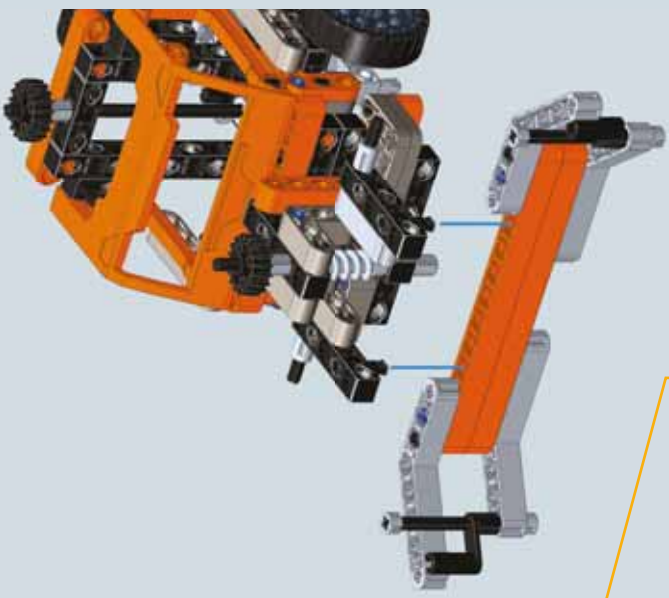

8

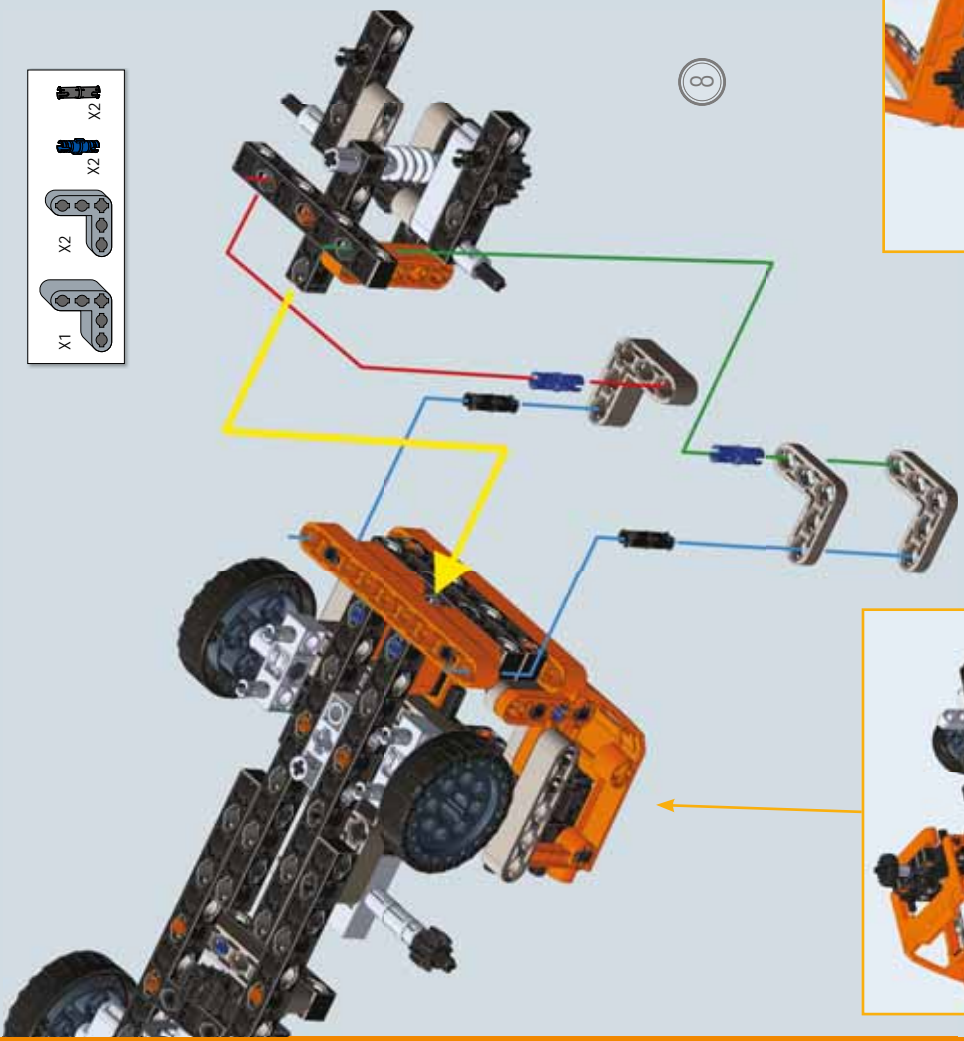
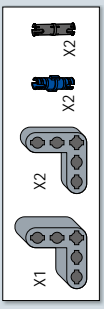

Model assembled in Activity 4



10

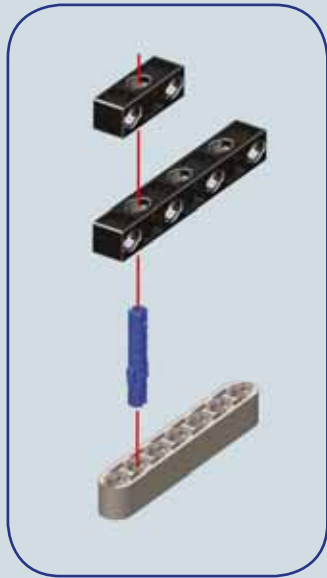
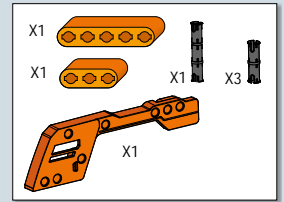

11

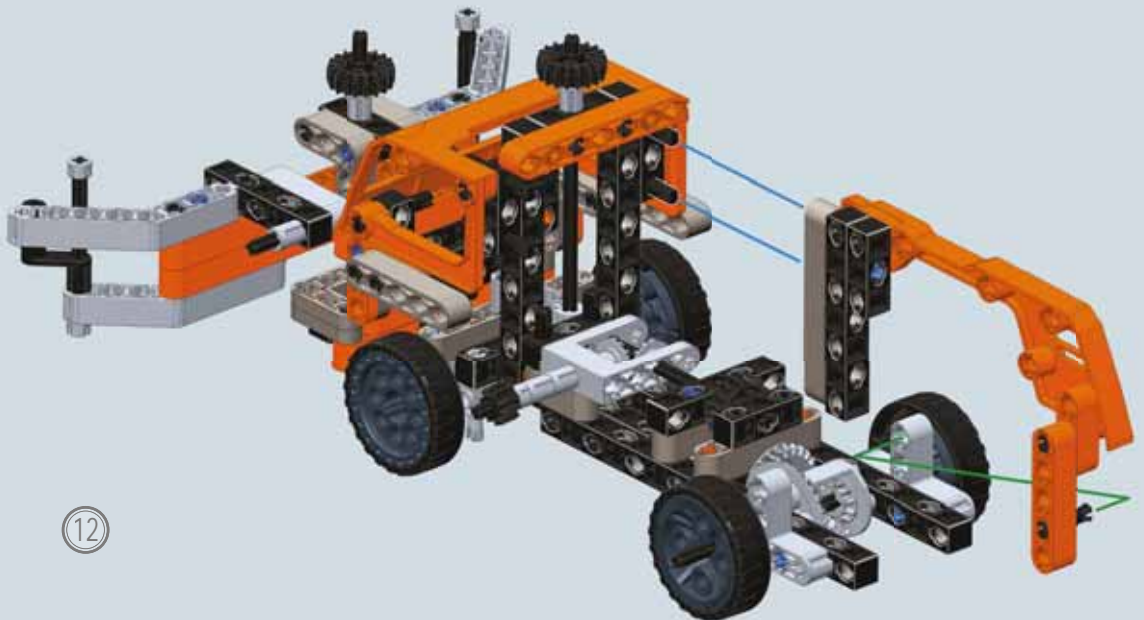
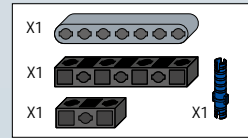
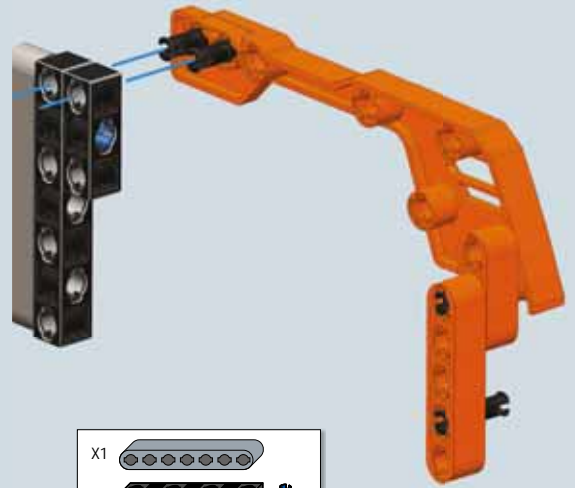

12

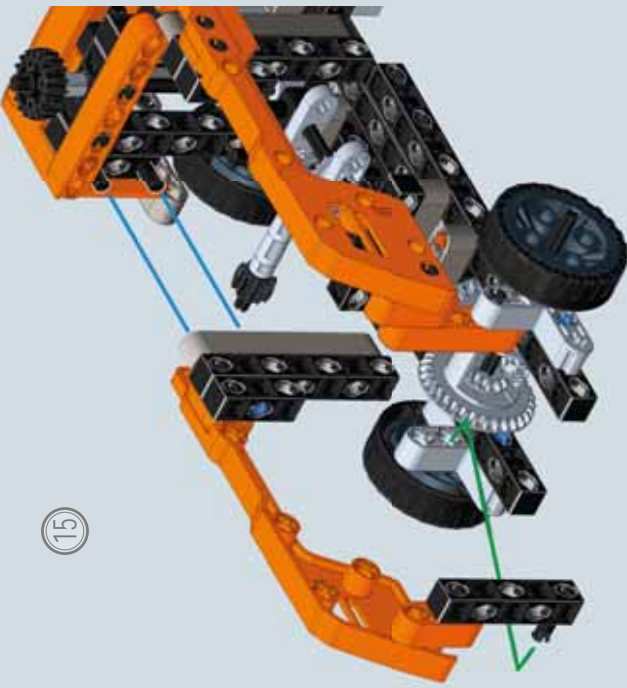

15

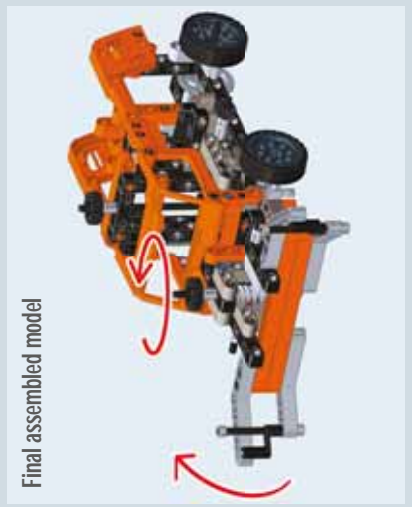

Final assembled model

14

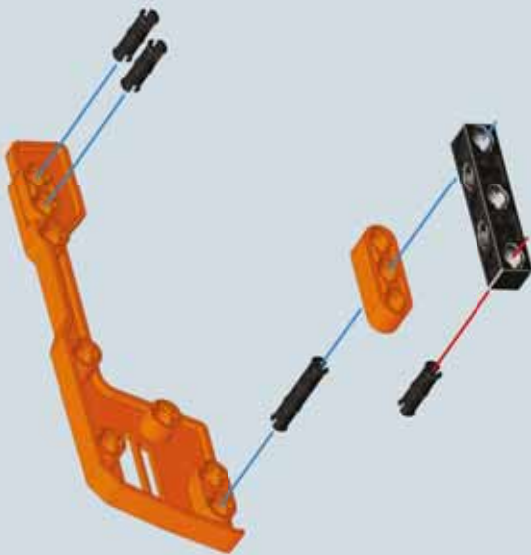

13

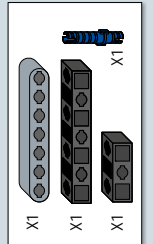
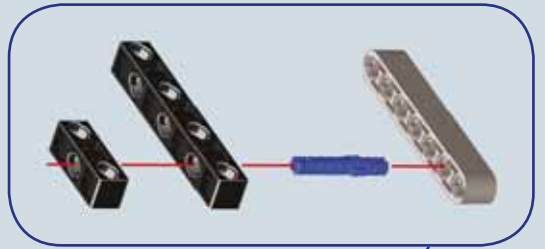
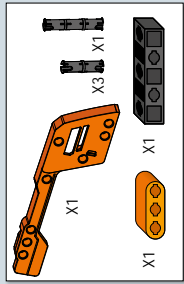



Technical facts and curiosities

A feature that makes American trucks readily identifiable is their long nose. Due to the absence of the restrictions implied in European traffic rules and the long distances they must cover, these trucks actually resemble travelling houses.

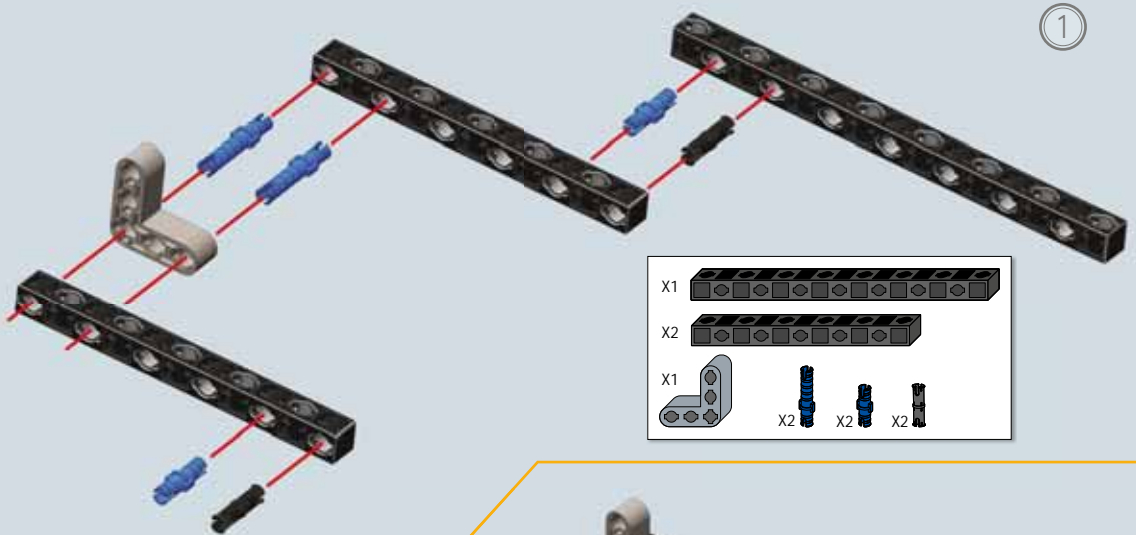

1

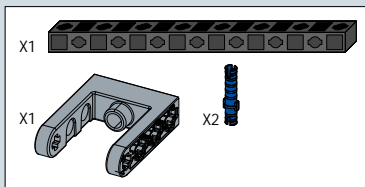
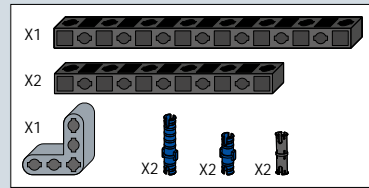

2

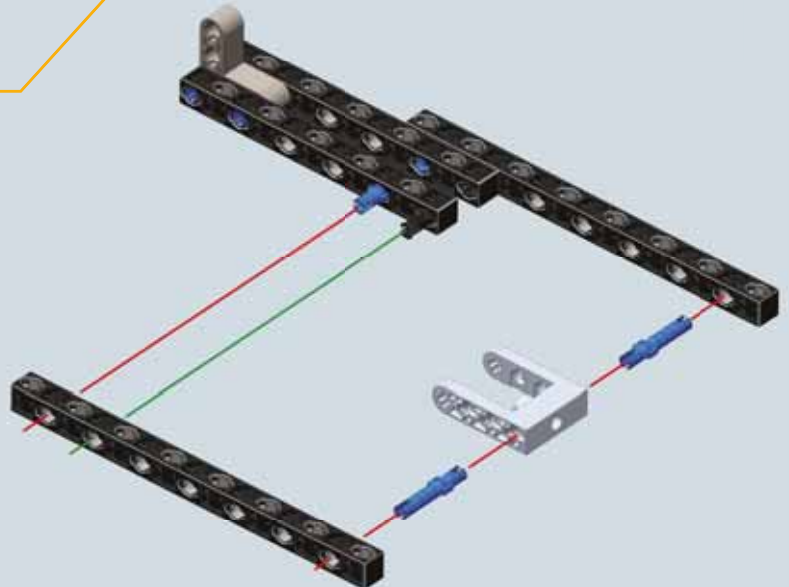

3

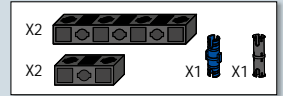
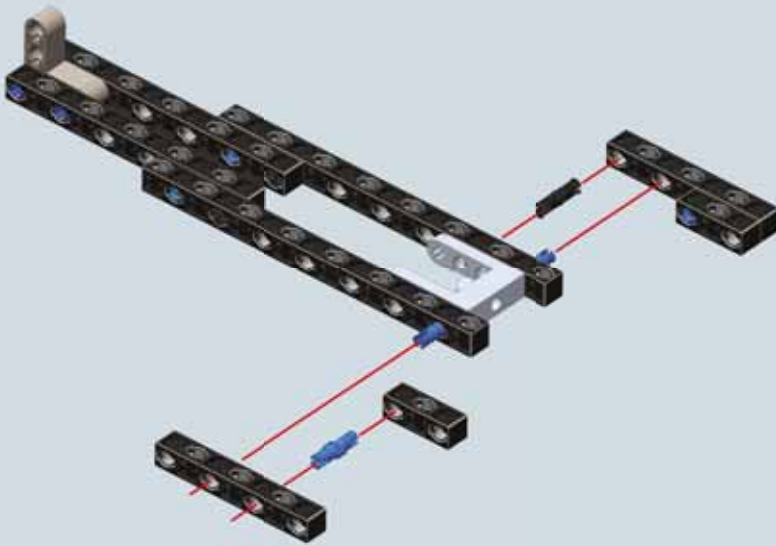

4

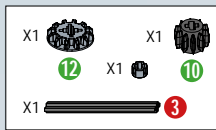
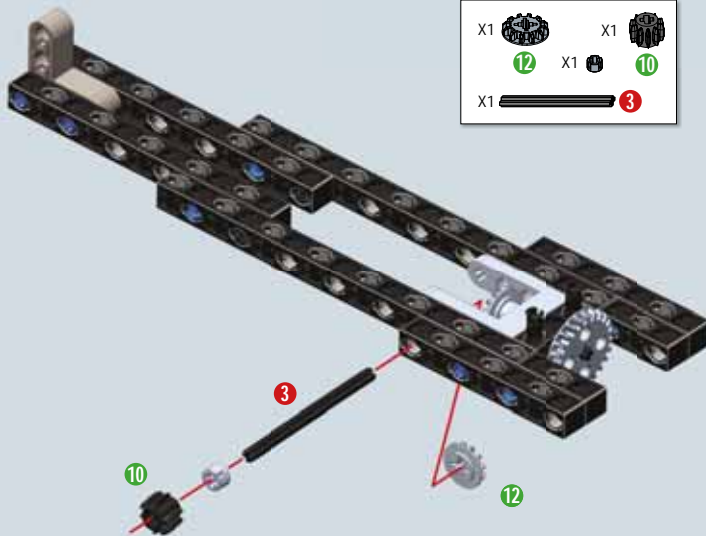
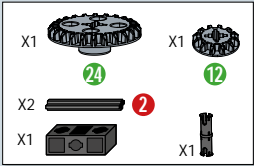
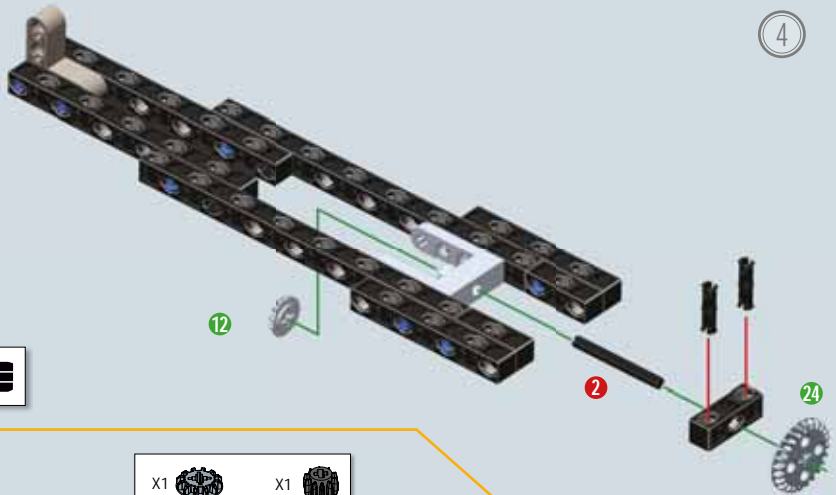

5

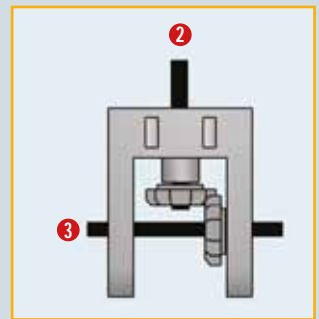

6

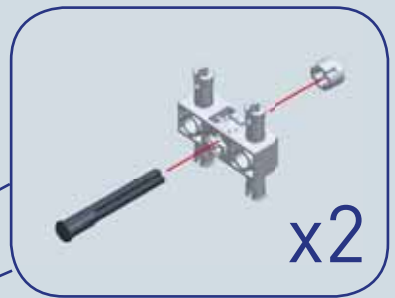
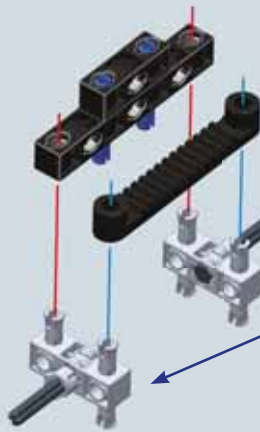
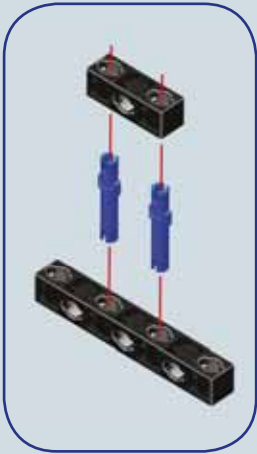
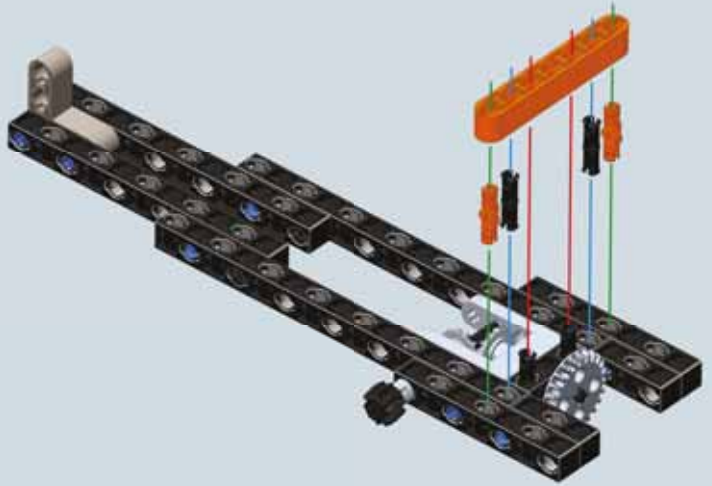

7

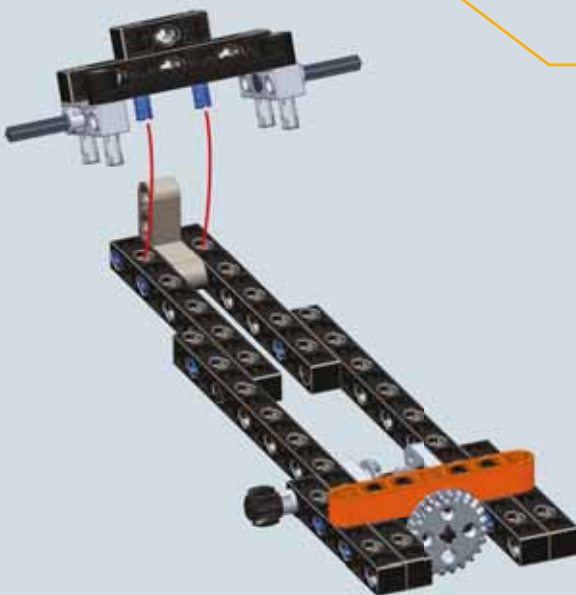
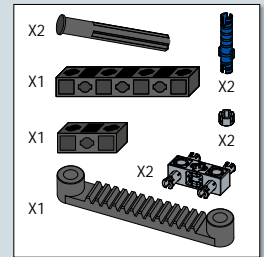

8

9

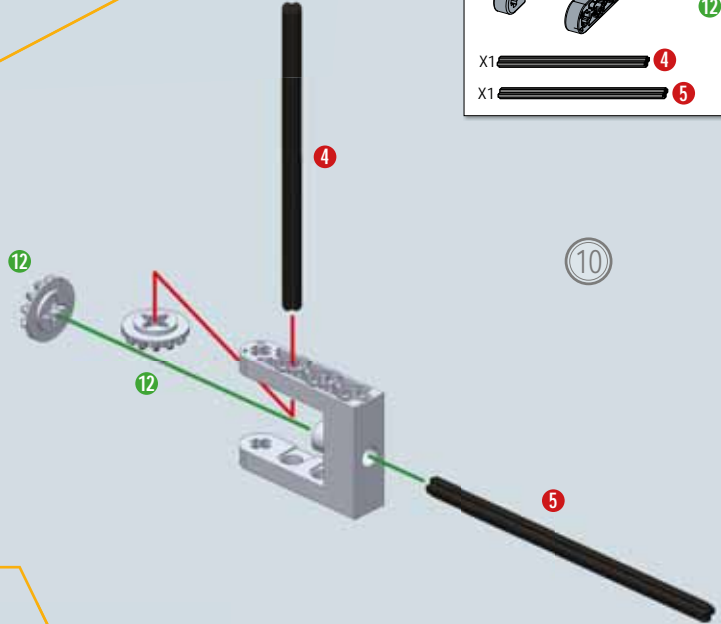
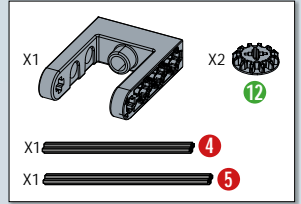
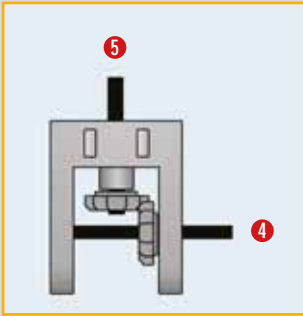
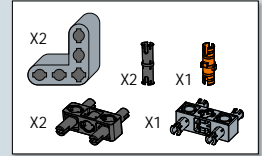
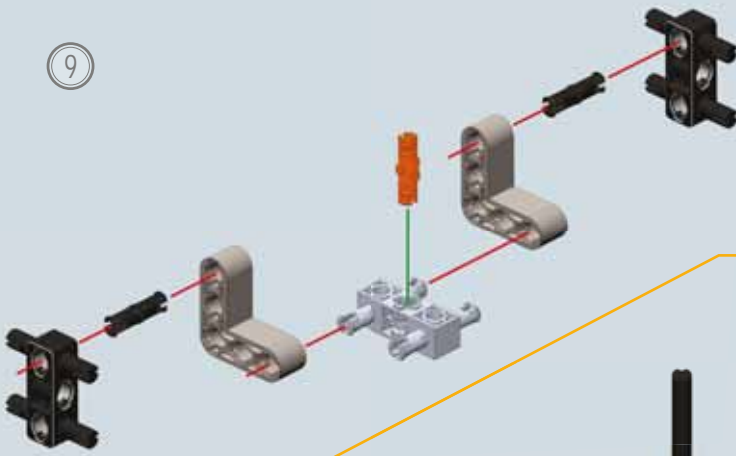

10



11

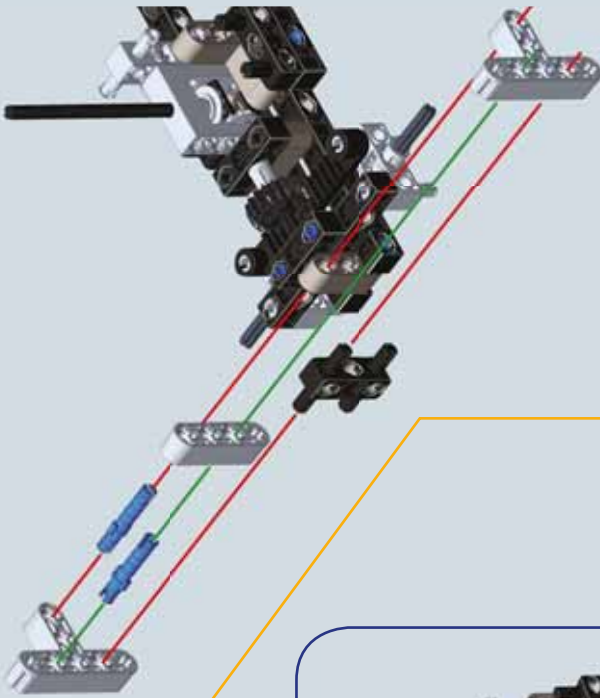

13

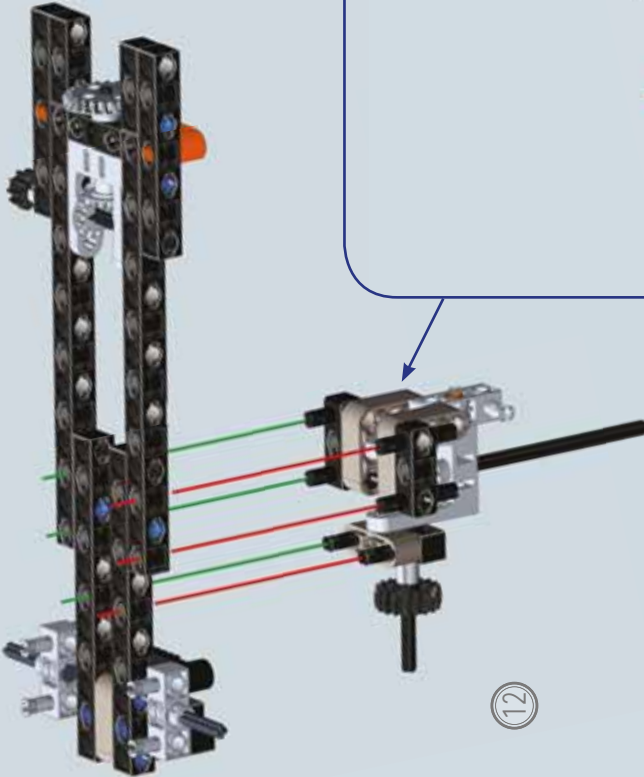
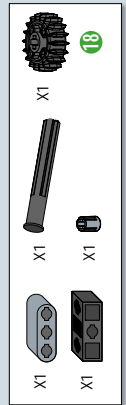
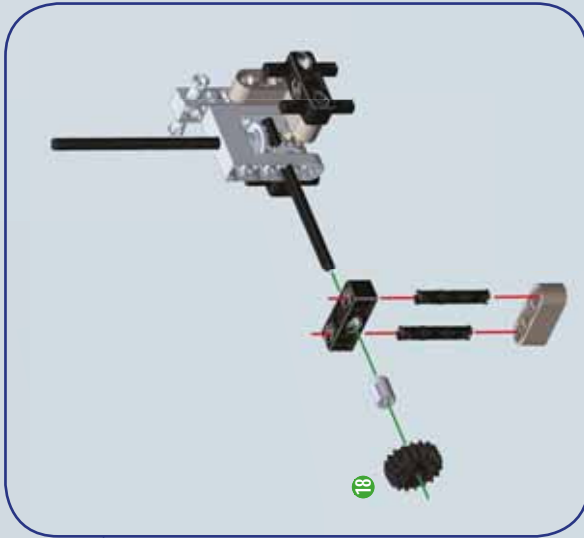
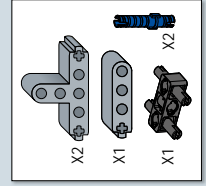

12

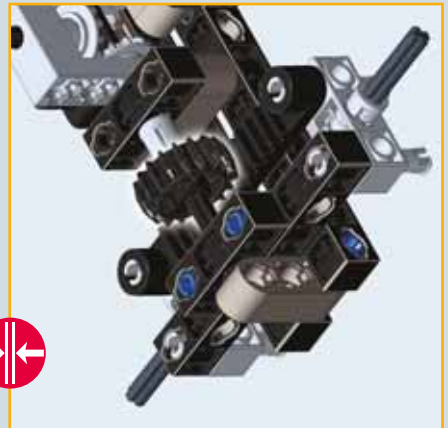

14

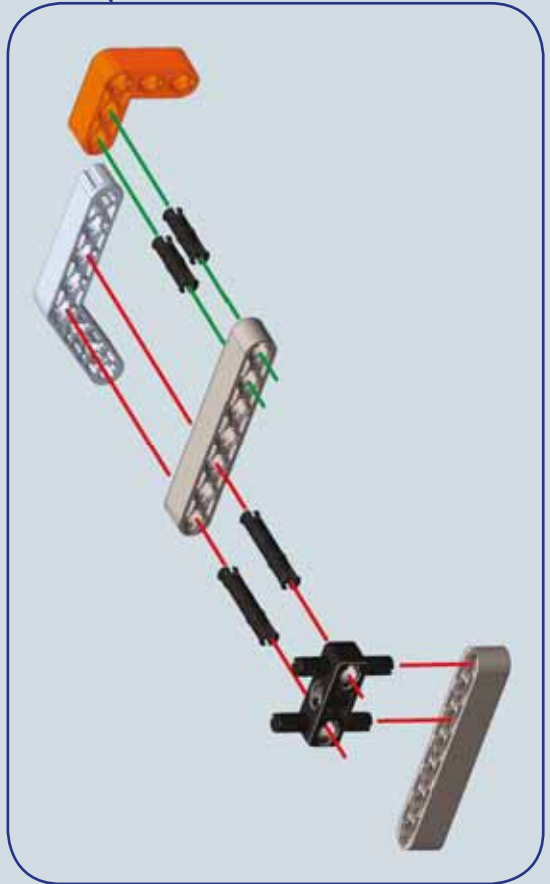
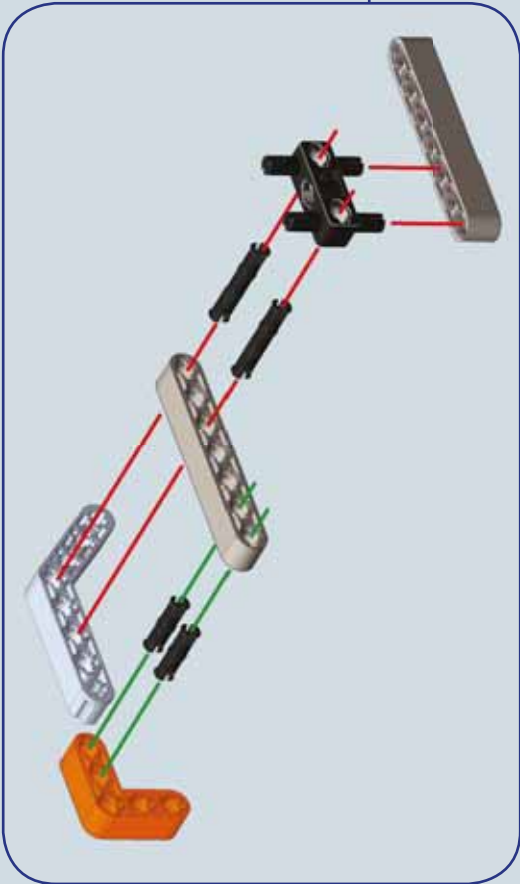
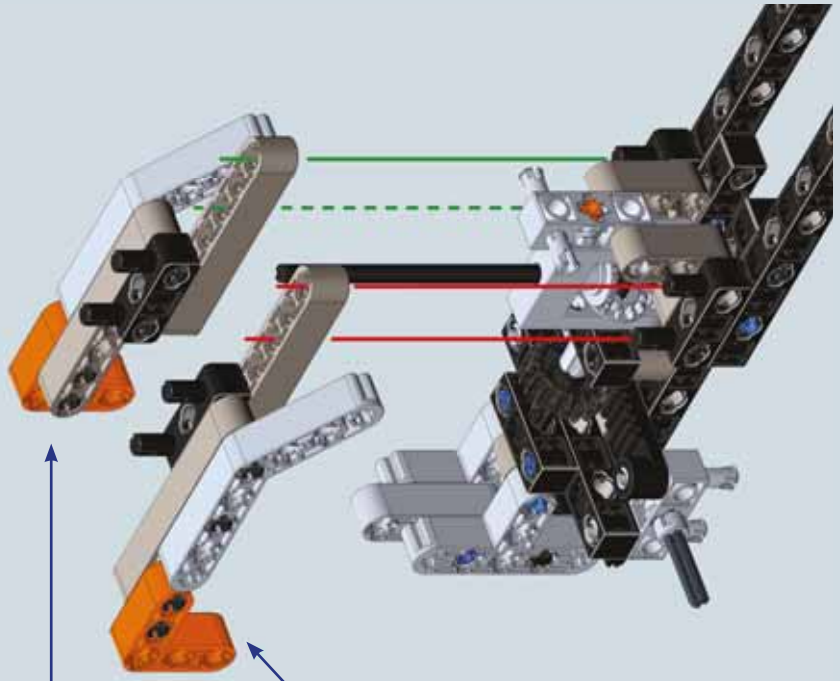
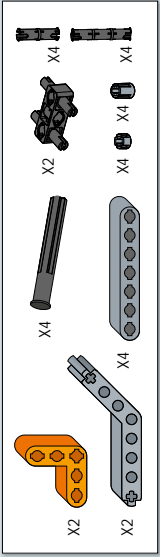

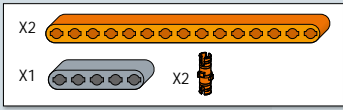

15



16

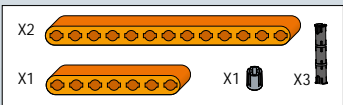
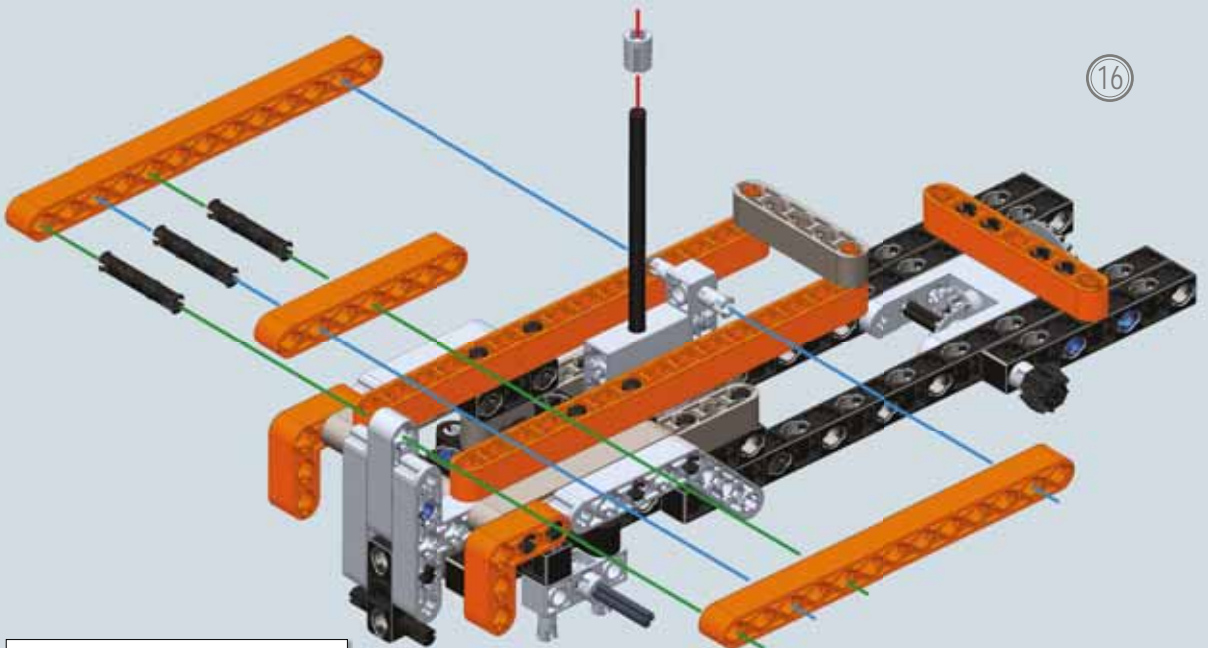



17

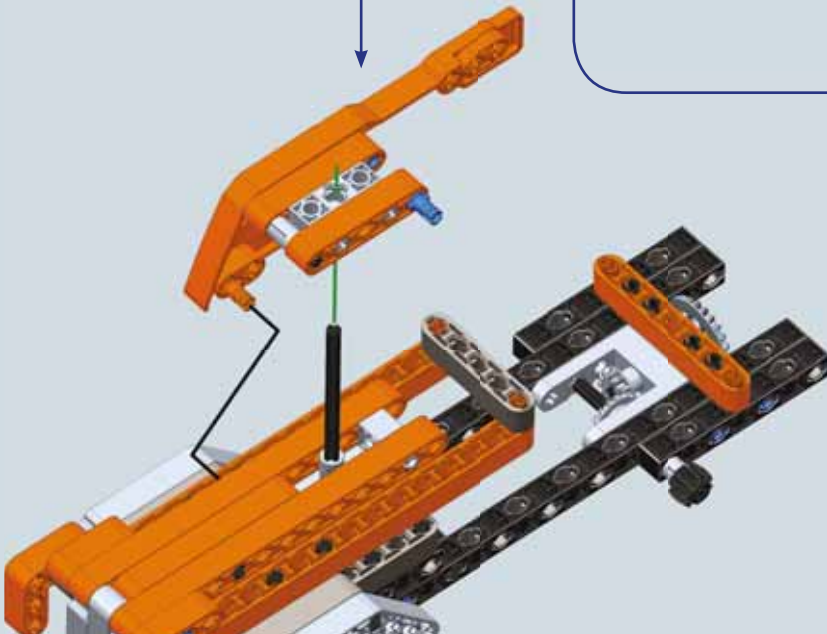
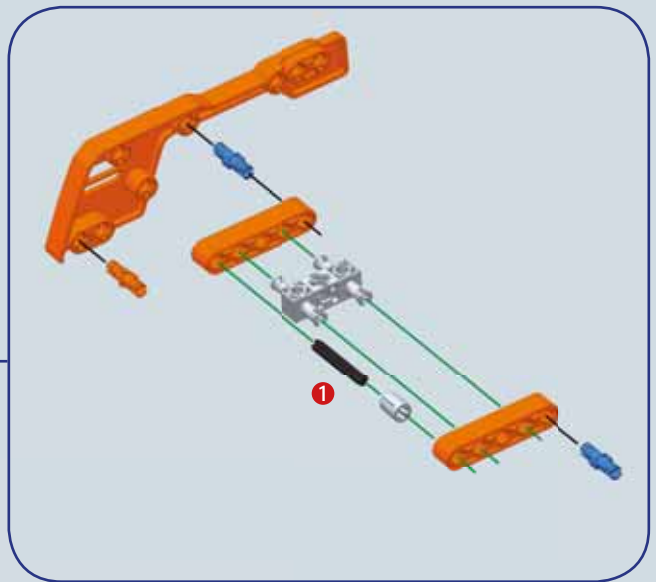
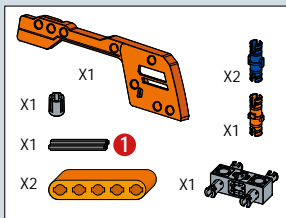
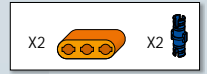

18



19

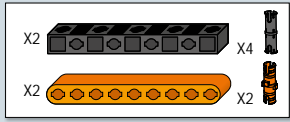
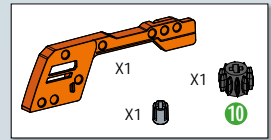
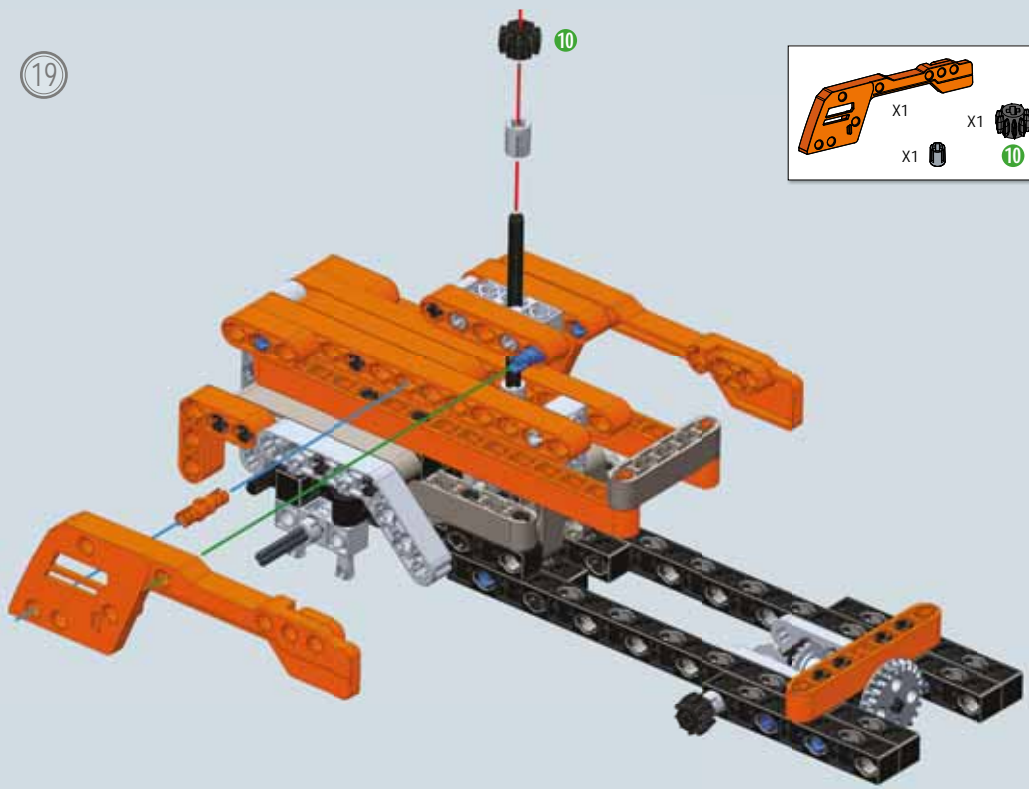

20

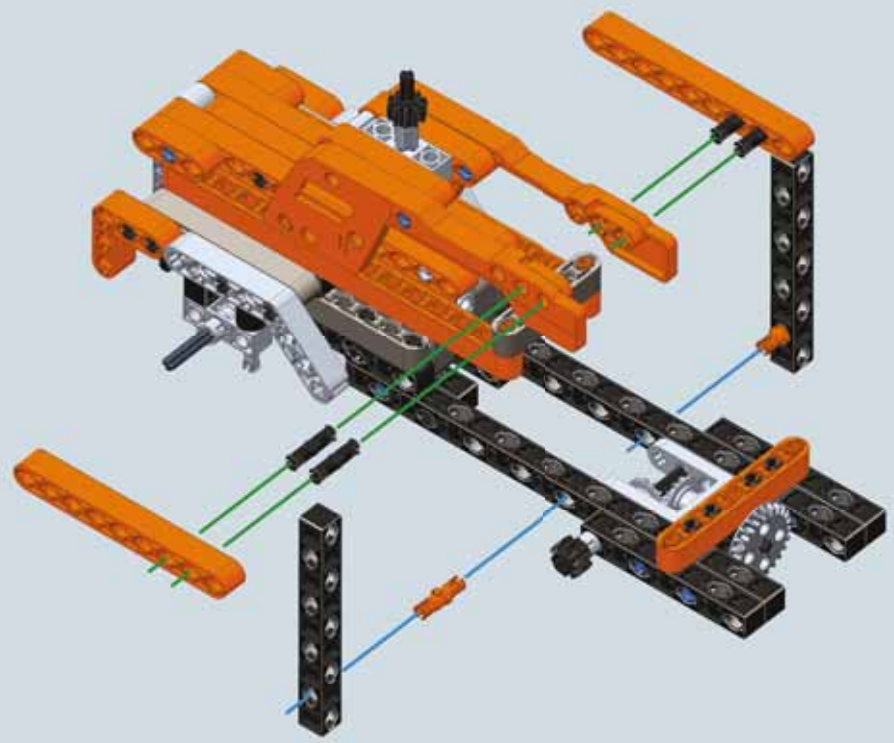

21

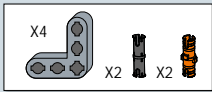
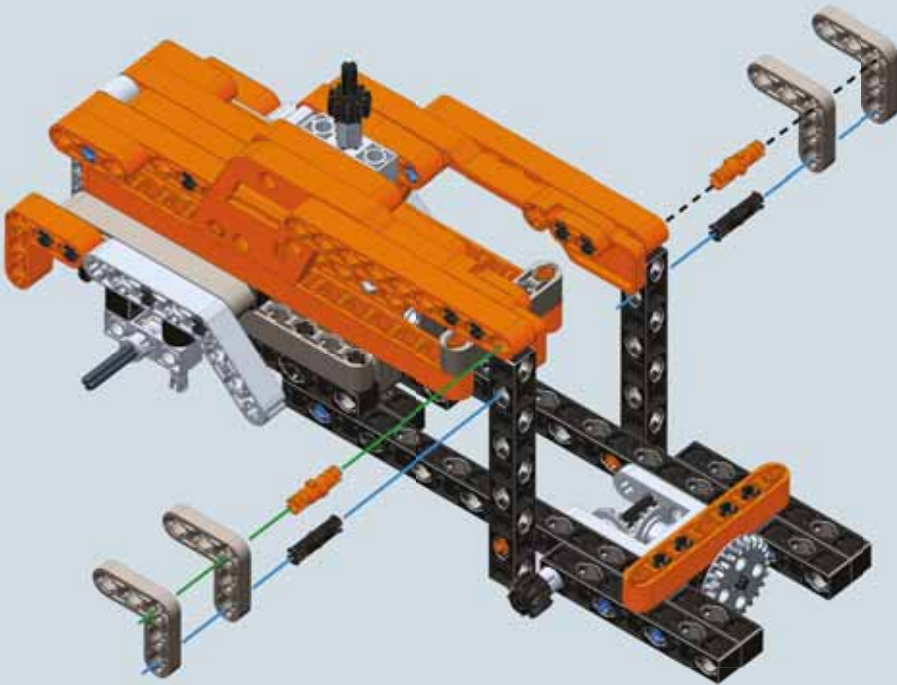

22

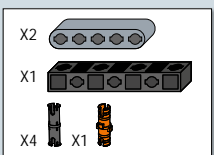
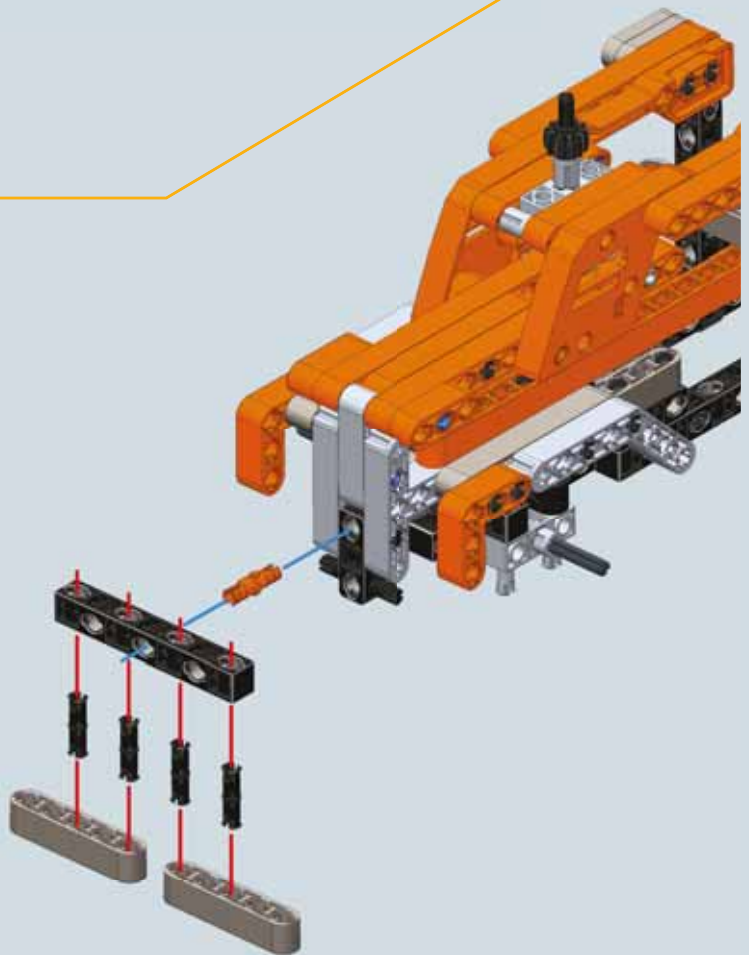

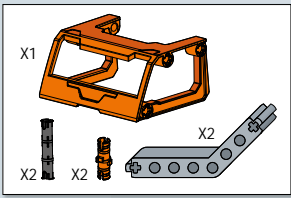

23

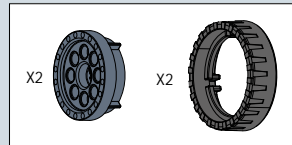
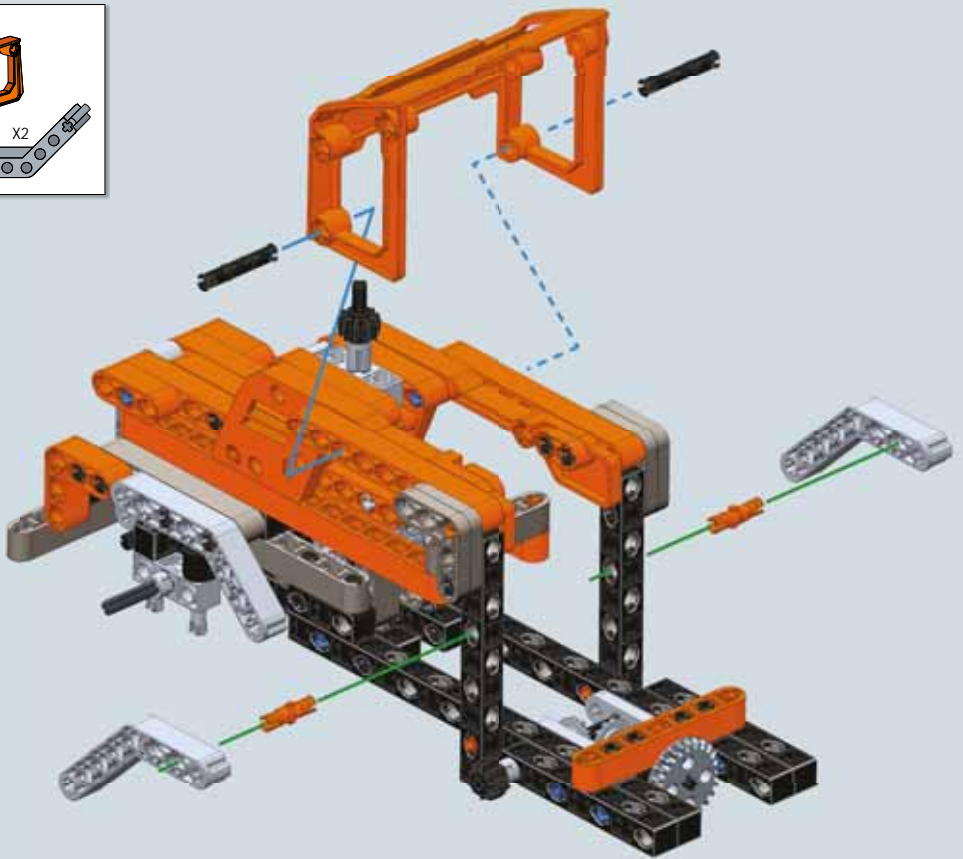

24

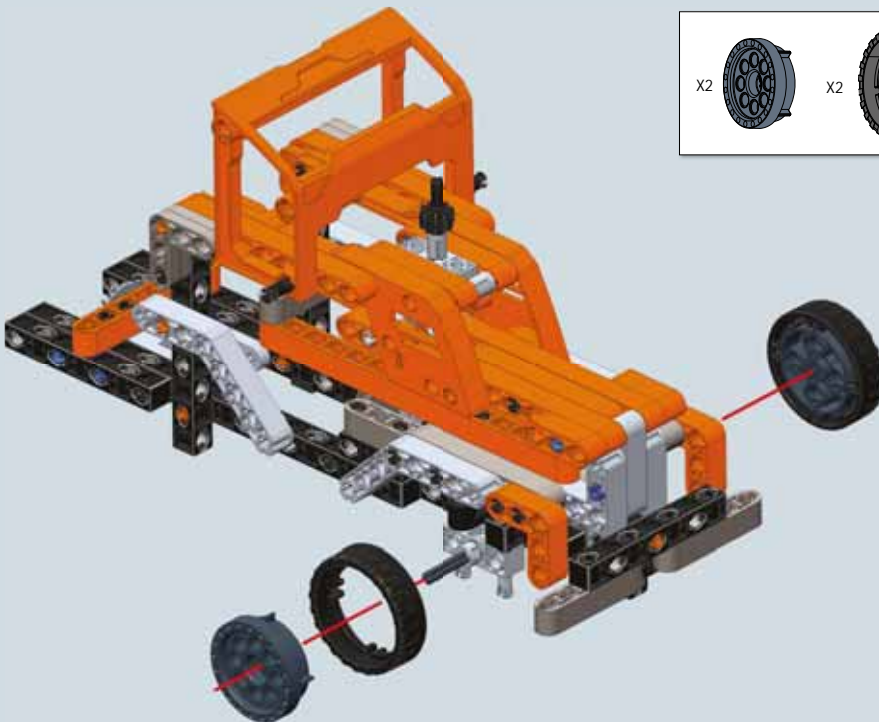

25

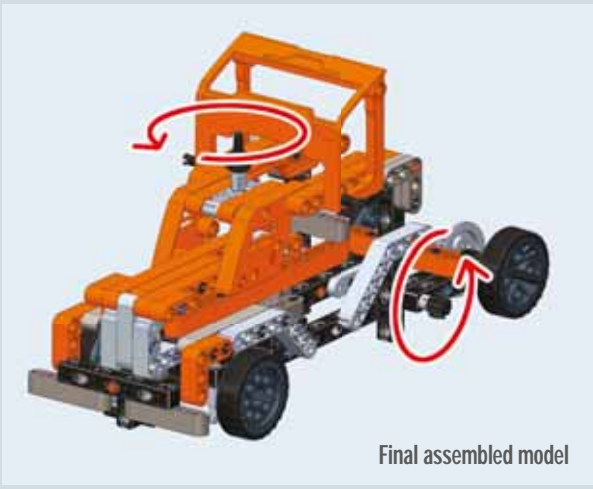
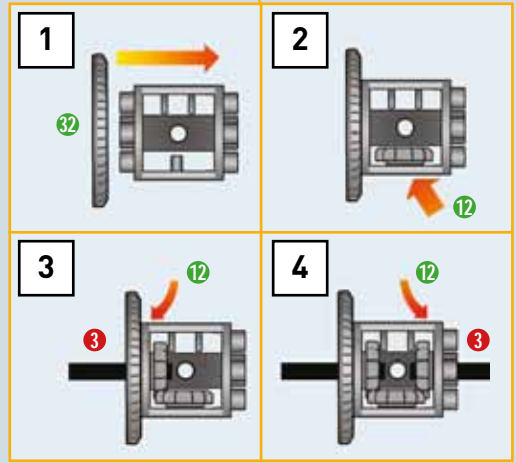
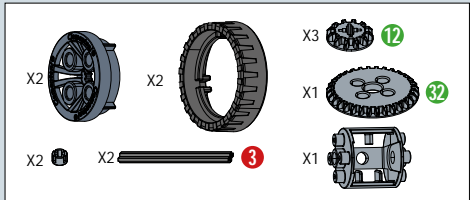
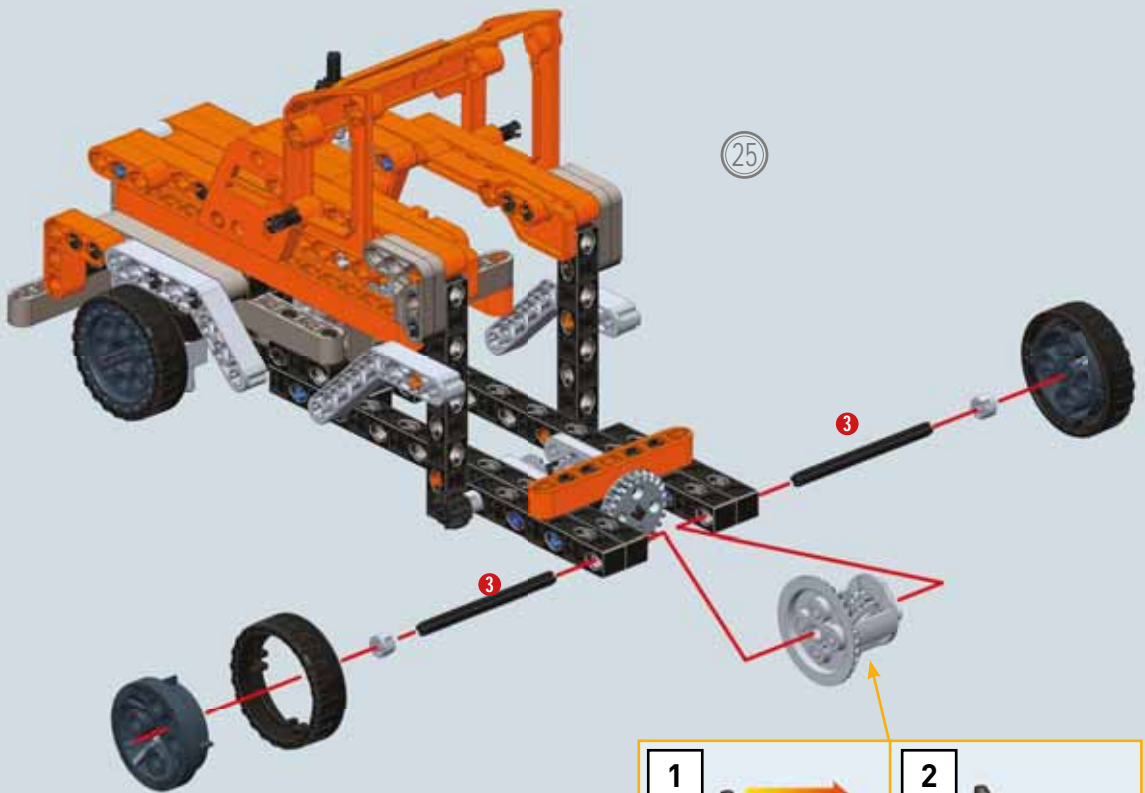

Final assembled model

