

1

**bilim
ve oyun**

TECHNOLOGIC

MEKANİK Laboratuvarı CANAVAR KAMYONLAR

Model 1-3

- 1 - Bağlama çubuğu ve piston
- 2 - Monster truck (Canavar kamyon)
- 3 - Spider truck (Örümcek kamyon)



1/46615

Kullanım kılavuzunu
okuyun ve ileride
başurmak üzere saklayın.

Clementoni tarafından ithal edilmiştir.
Clementoni Oyuncak San. ve Tic. Ltd. Şti.



Üretici Firma:

Clementoni S.p.A.
Zona Industriale Fontenoce s.n.c.
62019 Recanati (MC) - Italy
Tel.: +39 071 75811
www.clementoni.com

Küçükbakkalköy Mh. Tevfik Fikret Cd.
No:28/67 34750 Ataşehir / İstanbul
Tel: 0216 574 93 31
www.clementoni.com
Bilgileri referans için saklayınız.
İtalya'da üretilmiştir.



İÇERİK LİSTESİ

	15 delikli çift kiriş	2adet		Kısa manşon	12adet		10 dişli çark	2adet
	11 delikli çift kiriş	2adet		Uzun manşon	12adet		18 dişli çark	5adet
	9 delikli çift kiriş	2adet		Sonsuz vida	1adet		26 dişli çark	1adet
	7 delikli çift kiriş	4adet		Diferansiyel kutusu	1adet		41 dişli çark	1adet
	5 delikli çift kiriş	4adet		32 dişli çark	1adet		Şanzıman modülü	1adet
	3 delikli çift kiriş	4adet		24 dişli çark	1adet		Mil 7 uzunluk 9,9 cm	1adet
	7 delikli teklî kiriş	2adet		12 dişli çark	9adet		Mil 6 uzunluk 11,7 cm	1adet
	5 delikli teklî kiriş	2adet		Kısa çiftli köprü	32adet		Mil 5 uzunluk 8,1 cm	1adet
	3 delikli teklî kiriş	2adet		Kısa teklî köprü	8adet		Mil 4 uzunluk 7,2 cm	1adet
	Uzun L şekilli kiriş	2adet		Kısa serbest köprü	32adet		Mil 3 uzunluk 5,4 cm	5adet
	Kısa L şekilli kiriş	2adet		Uzun çiftli köprü	8adet		Mil 2 uzunluk 3,6 cm	2adet
	7 delikli teklî kiriş	4adet		Uzun serbest köprü	16adet		Mil 1 uzunluk 2,7 cm	1adet
	5 delikli teklî kiriş	4adet		Köprülü kiriş	2adet		Kardan mafsalı	2adet
	3 delikli teklî kiriş	4adet		Pimli kiriş	4adet		Lastik	2adet
	Uzun L şekilli kiriş	4adet		Kanca	1adet		Dikdörtgen ışık	2adet
	Kısa L şekilli kiriş	4adet		Döner kol	2adet		Yuvarlak ışık	2adet
	4 delikli çift kiriş	1adet		Kremayer dişli mil	1adet		Siren	1adet
	T şekilli kiriş	1adet		Kısa çiftli köprü	2adet		Sağ "O" panel	1adet
	L şekilli kiriş	2adet		Küçük tekerek	4adet		Sol "O" panel	1adet
	4 delikli teklî kiriş	2adet					"P" panel	1adet
	T şekilli kiriş	2adet					"Q" panel	1adet
	L şekilli kiriş	4adet					Sağ "E" panel	1adet
							Sol "E" panel	1adet
							Jant	4adet

DIKKAT!Parçaları plastik ek yerlerinden çıkarmak için bir yetışkından yardım isteyin. Tüm keskin uçlar derhal çıkarılıp atılmalıdır.



BİR YETİŐKİNDEN SIZE YARDIM ETMESİNİ İSTEYİN!

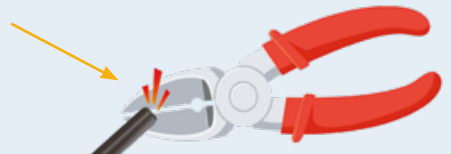

İçten yanmalı motor, kimyasal enerjiyi mekanik güce çeviren bir makinedir. Mekanik güç üretebilmek için şunlara ihtiyaç duyarız:

- **Yakıt:** gaz, benzin veya dizel
- **Oksitleyici madde:** oksijen
- **Yanma odası:** tepkimenin meydana geldiği motorun metal gövdesi

Nasıl çalışır? Yanma 4 aşamada gerçekleşir:

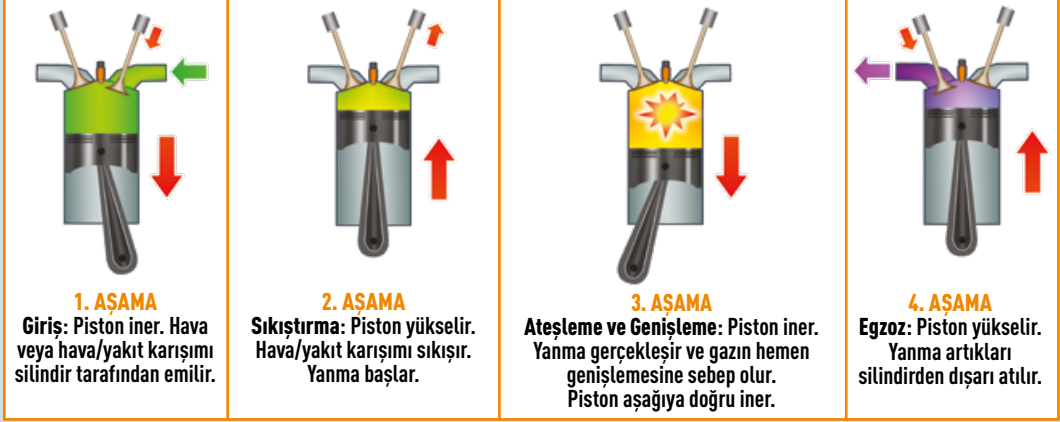

Her döngü, motor milini iki kez döndürür ve motor mili, hareketi aracın diğer mekanik parçalarına iletir.

Diferansiyel

Diferansiyel, motor tarafından üretilen gücü tahrik tekerlerine aktarabilen mekanik bir cihazdır.

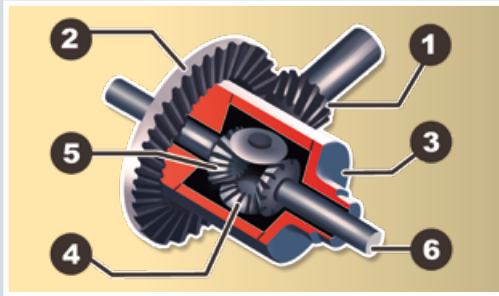

1. **Pinyon dişlisi:** Gücü motordan ayna dişlisine ve son olarak da motor dişlisine aktarır.
2. **Ayna dişlisi:** Diferansiyel kutusuna bağlıdır ve pinyon dişlisine sürekli akuple haldedir.
3. **Diferansiyel kutusu:** Dişlilerin yer aldığı kutudur.
4. **İstavroz dişliler:** Kutuya monte edilmiş dişlilerdir.
5. **Aks dişlileri:** Aks millerine takılı dişliler.
6. **Aks mili:** Tahrik dişlilerini aks dişlilerine bağlayan millerdir.

Kilitli diferansiyel

Arazi araçlarında kilitli diferansiyel bulunur. İki tekerleğin birinin zemini kavrayamaması durumunda diferansiyel etkin bir biçimde hareket edemeyebilir: Bu durumda, zemini daha iyi kavrayan tekerlek sabit kalırken diğer tekerlek kayar. Elektronik kontrollü mekanizmalar sayesinde kilitli diferansiyel, motor gücünün iki tekerleğe eşit bir biçimde dağıtılmasını sağlar ve böylece zemini kavramanın zorlaştığı her durumda hareket gücünü artırır.



Süspansiyonlar ve darbe emiciler

Şu anda piyasada satılan tüm araçlarda, yolculuk sırasında maksimum konfor sağlamak için bir süspansiyon sistemi bulunur. Süspansiyonlar olmadan, tekerleklerle etki eden tüm kuvvetler doğrudan yolcu bölümüne aktarılır ve sürücü aracı kontrol edemeyebilir.



Süspansiyon ve darbe emici terimleri genellikle yanlış şekilde kullanılır. Aslında ikisi arasında fonksiyonel bir farklılık vardır:

- Yukarıda bahsedildiği gibi, süspansiyonlar yolcu konforunu garanti etmek için elastik elemanlar aracılığıyla askıda olmayan kısımları (tekerlekler) askıdaki kısımlara (yolcu bölümü, motor vb.) bağlar. Yandaki görüntüde yay ve dahili kılavuz (siyah) süspansiyonu oluşturur.
- Diğer yandan, darbe emiciler, süspansiyonların hareketini yavaşlatan, süspansiyonlarla ilişkili bileşenlerdir. Yayı sıkıştırırsak başlangıçtaki durumuna geri dönmeye zorlanır, böylece süspansiyonların etkisini yok eder. Gaz veya sıvı bazlı debriyaj sistemleri sayesinde, darbe emiciler yayın başlangıç konumuna daha yumuşak bir şekilde dönmelerini garanti eder.



Monster truck

Dev lastiklere, 4 tekerlekten çekişli ve 4 tekerleğe de yön verilebilen bir sisteme, büyük yüksekliklerden inişlere dayanıklı süspansiyonlara ve güçlü motorlara sahiptir. Canavar kamyonlar, hem sürücüye hem de gösteriyi izleyenlere bol miktarda heyecan verebilen bir ekstrem araçtır.



Canavar kamyonun teknik özellikleri aşağıdaki gibidir:

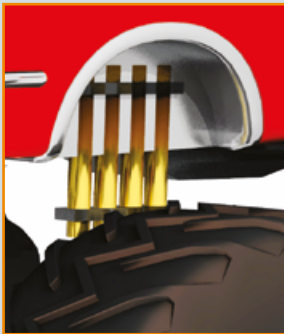

- **LASTİKLER:** En fazla 1,60 m yüksekliğe ve 400 kg ağırlığa sahip olabilirler
- **DARBE EMİCİLER:** Her tekerlek 4 gaz darbe emiciye (yandaki görüntü) sahip bir süspansiyon sistemine bağlıdır.
- **TEKERLEKLER:** 4 tekerleğin tamamına direksiyondan yön verilebilir ve aracın dar alanlarda manevra yapmasına olanak tanır.
- **DİFERANSİYEL:** Otomatik kilitlenen diferansiyel, motor gücünü 4 tekerleğin tamamına aktarır. Bu diferansiyel türü, tek bir tekerlek bile yere temas ettiğinde aracın hızlanmasını sağlar.
- **MOTOR:** Aracı dengeli hale getirmek için merkezi konuma monte edilir. Kısa mesafeli yarış arabalarına benzer inanılmaz seviyelerde yüksek güç geliştirmek için özel yakıtlar kullanır.
- **ŞAŞİ:** Son derece dayanıklıdır ve sürücüyü korumak için çelik borulardan yapılmıştır.
- **KAPORTA:** Son derece hafif ve esnek. Aracı daha iyi tanımlamak için, yaygın olarak kullanılan araç kaportalarından elde edilebilir.

1 Bağlama çubuğu ve piston



MEKANİK LABORATUVARI
UYGULAMASINDA İNTERAKTİF 3D TALİMATLAR

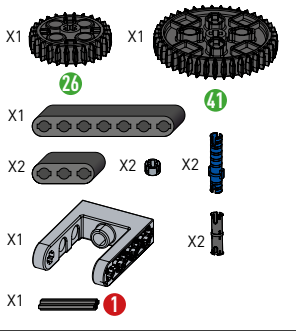
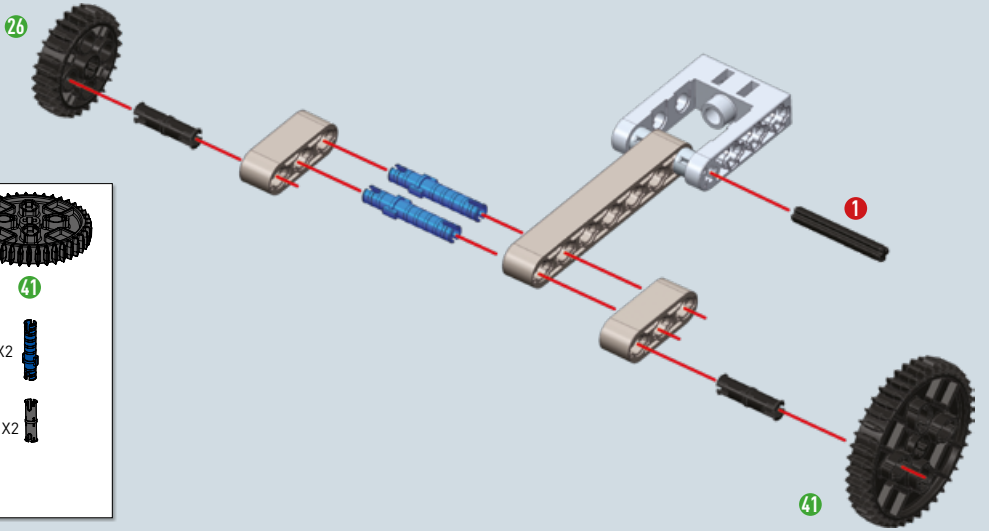
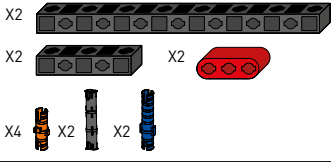
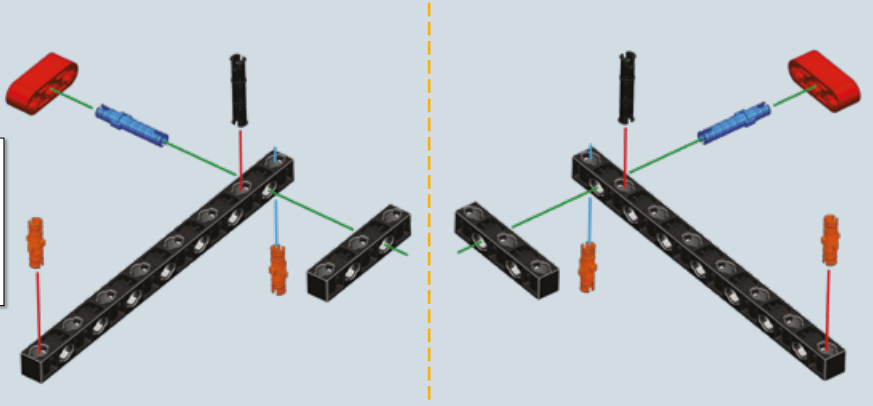
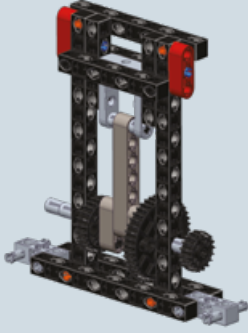

3

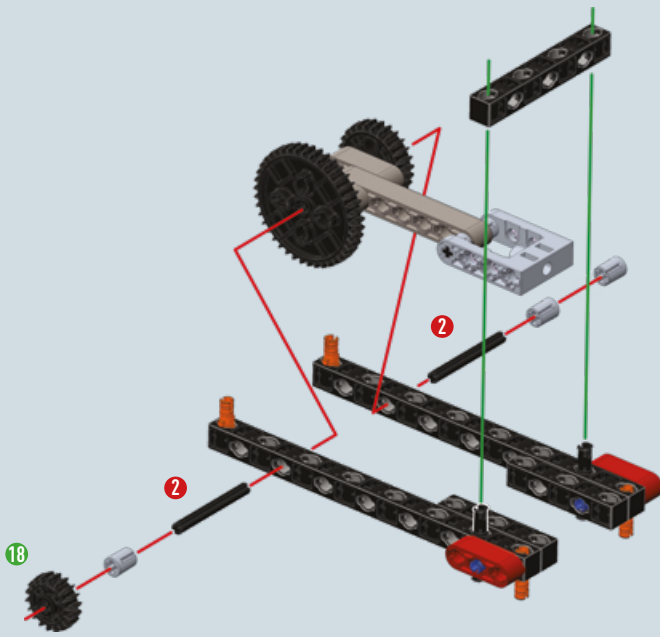

- | | | | |
|----|--|----|--|
| X1 | | X1 | |
| X2 | | X3 | |



4

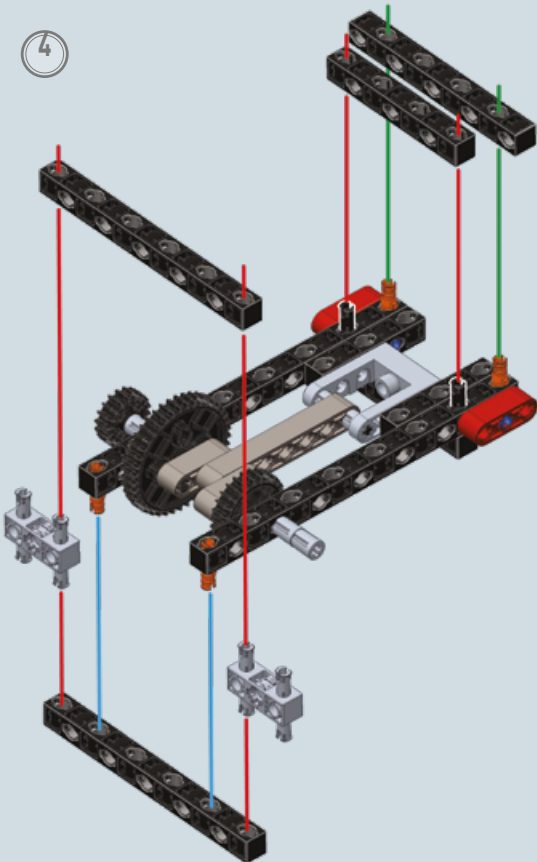

- | | |
|----|--|
| X2 | |
| X1 | |
| X1 | |
| X2 | |

Montajı tamamlanmış model

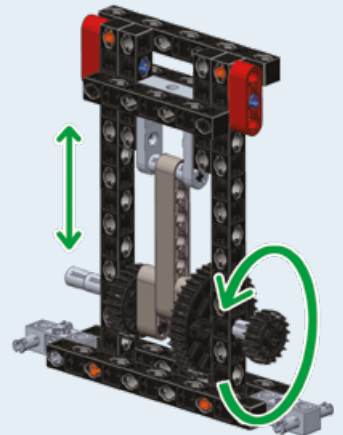

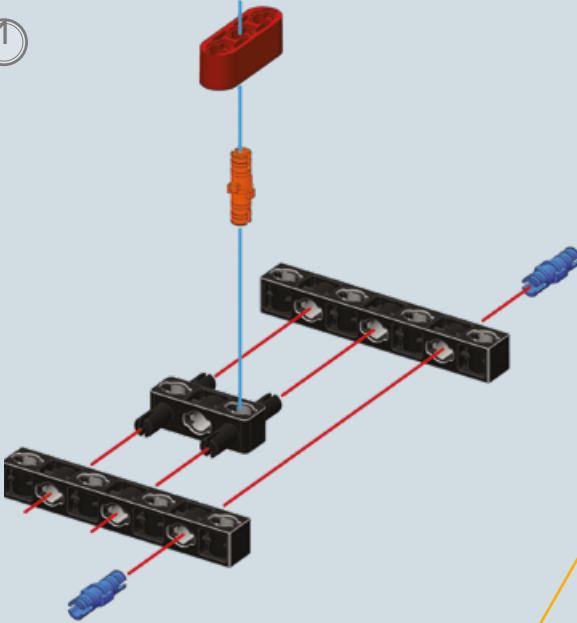

- X2
- X1
- X1 X1 X2



- X1
- X2 X2 X2

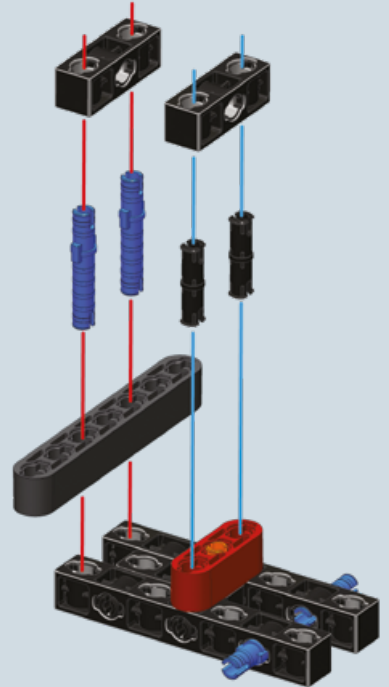

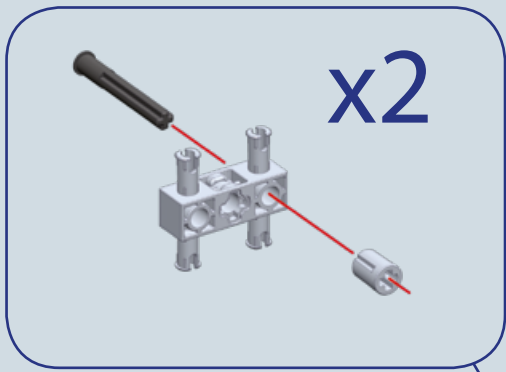

3

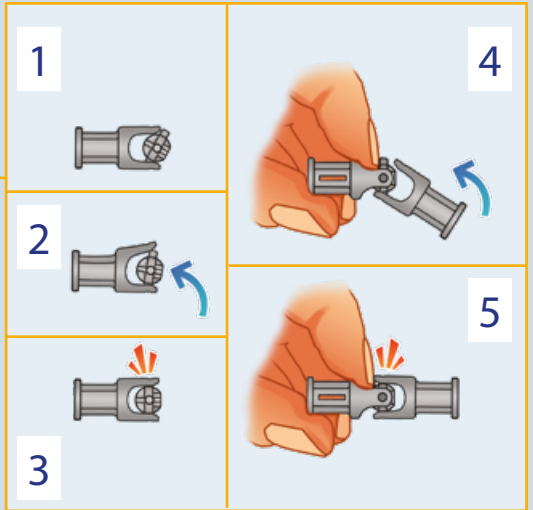
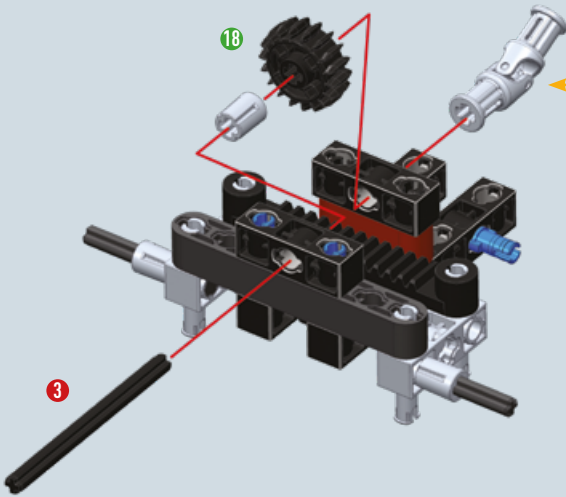
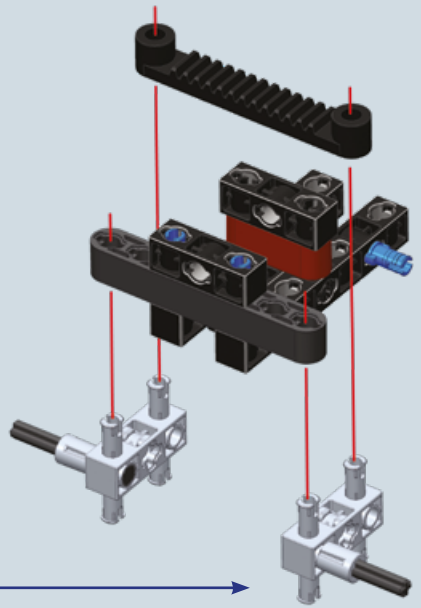
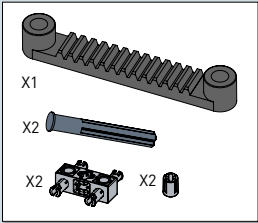

4

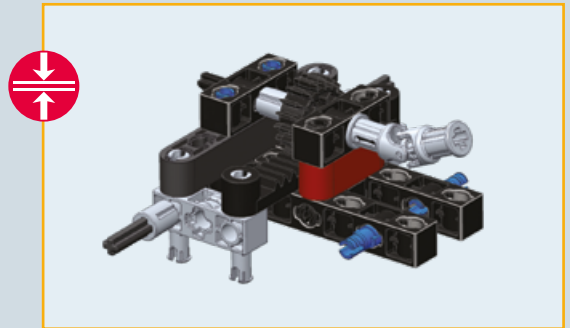
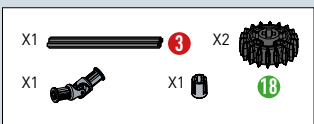

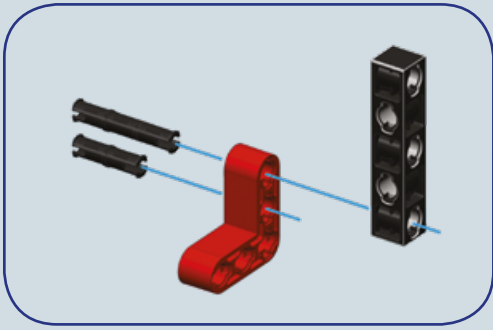

5

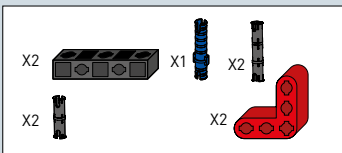
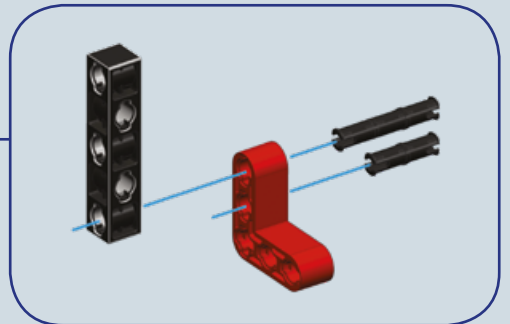
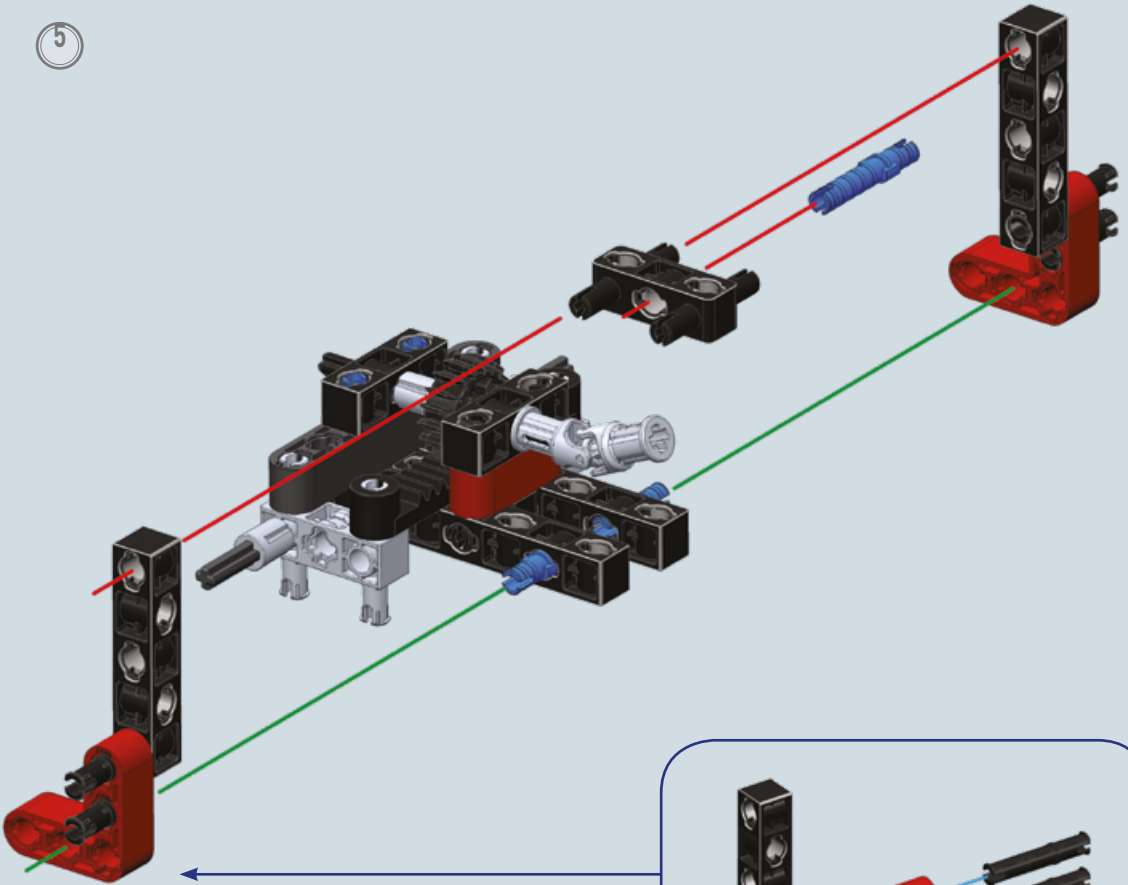

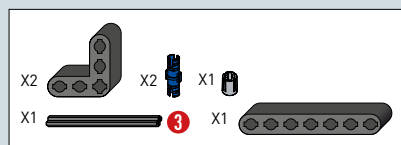
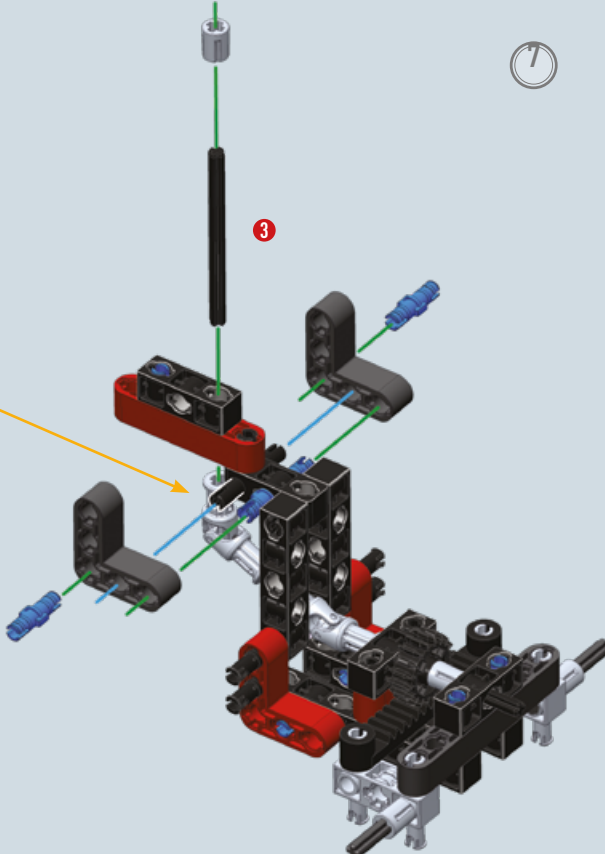
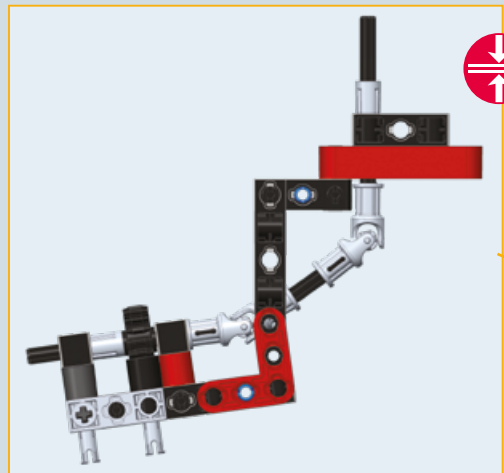
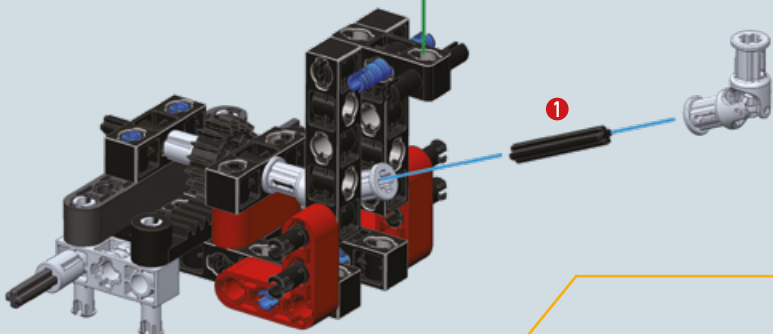
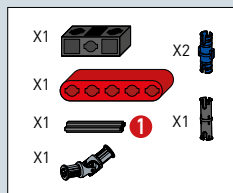
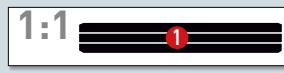
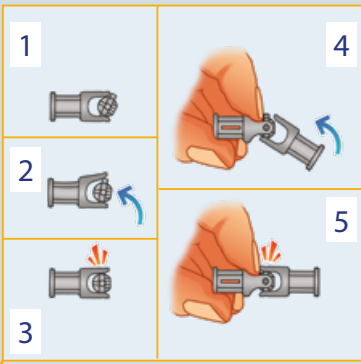
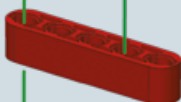

8

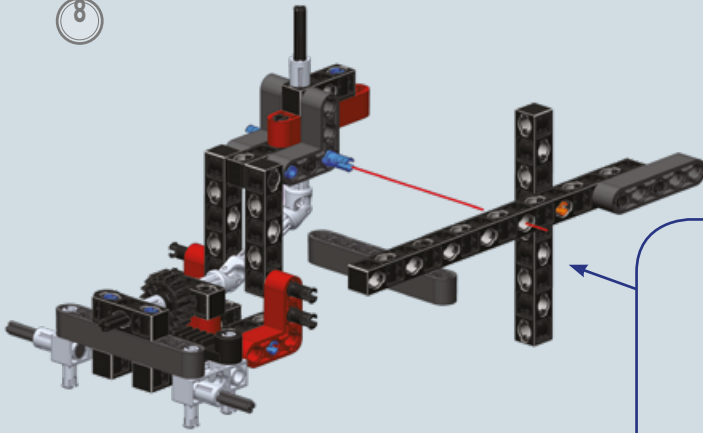

- X1
- X1
- X1 X3 X1
- X1

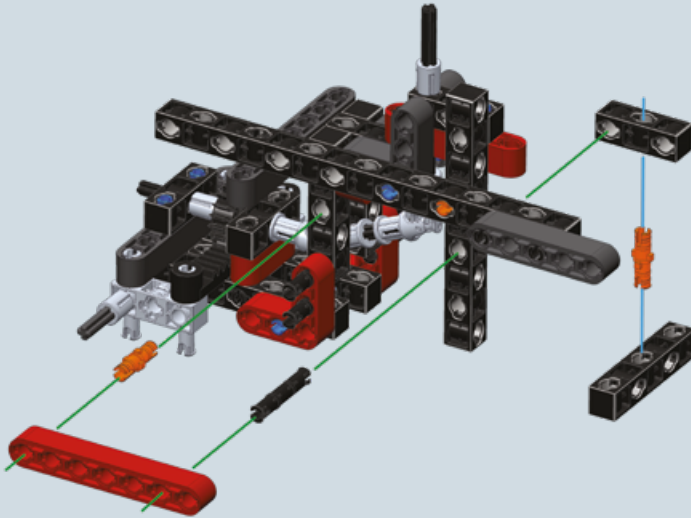
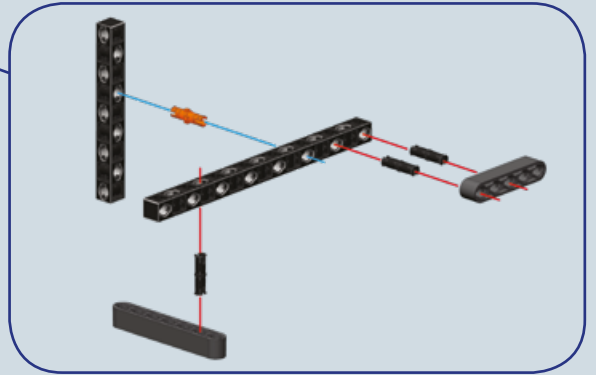

- X1
- X1
- X1
- X1
- X2

9

10

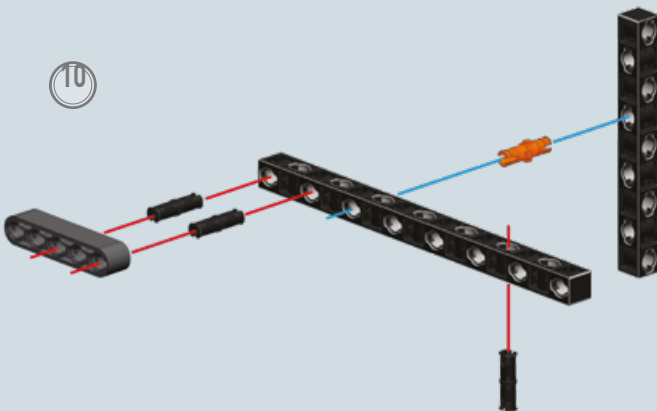

- X1
- X1
- X1 X3 X1



11

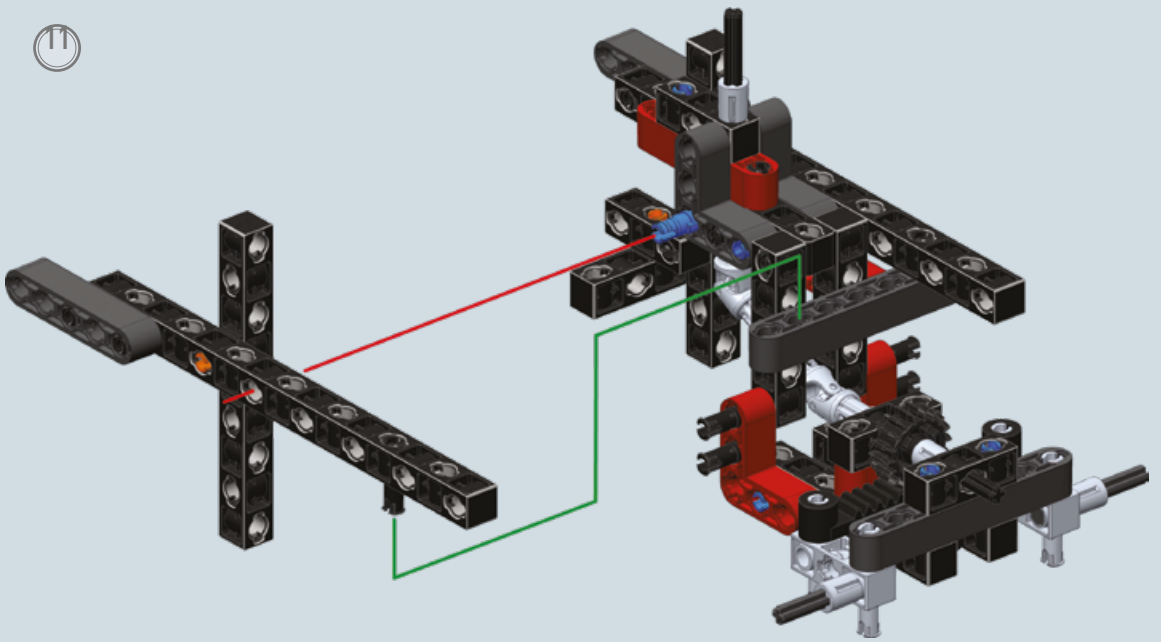

12

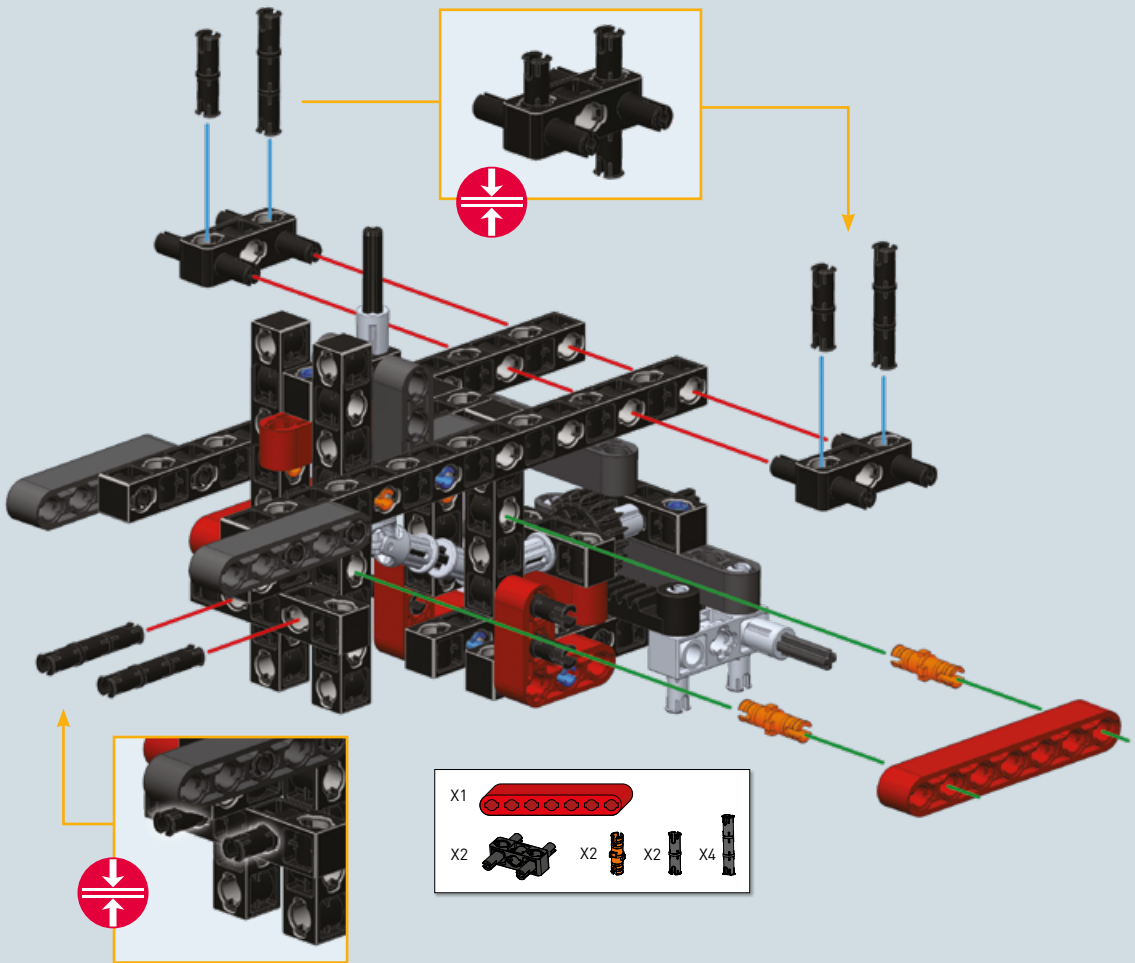

13

X1 

X1  X2 

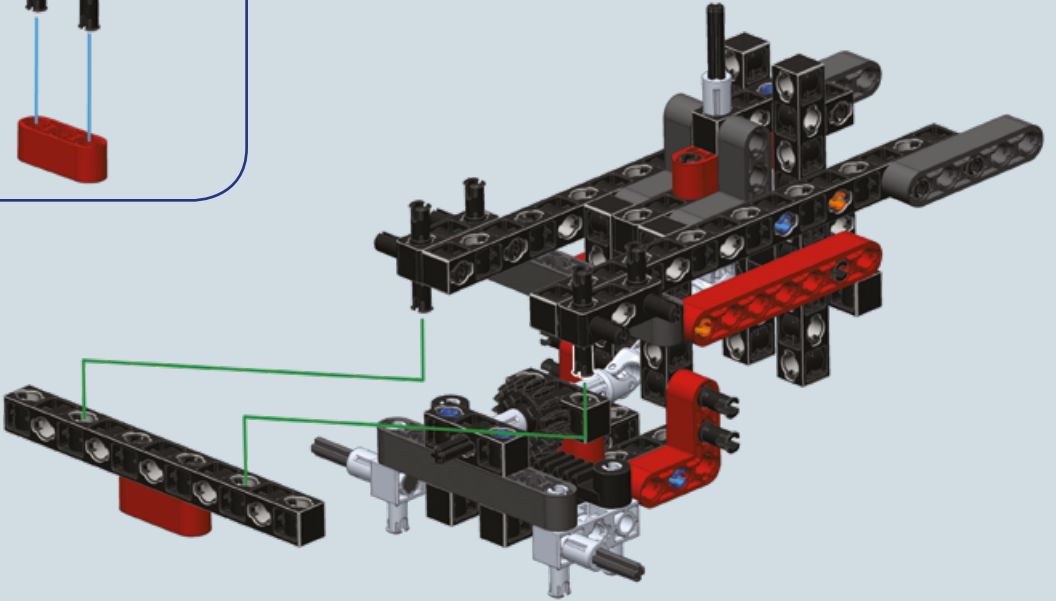
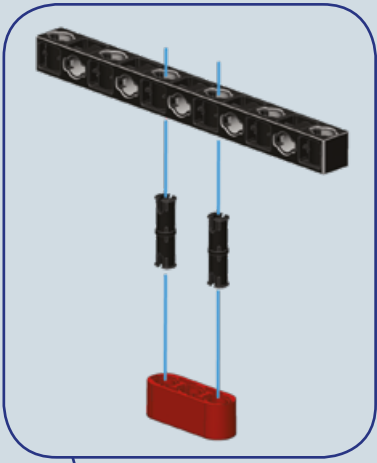

X1 

X1  X2  X1 

14

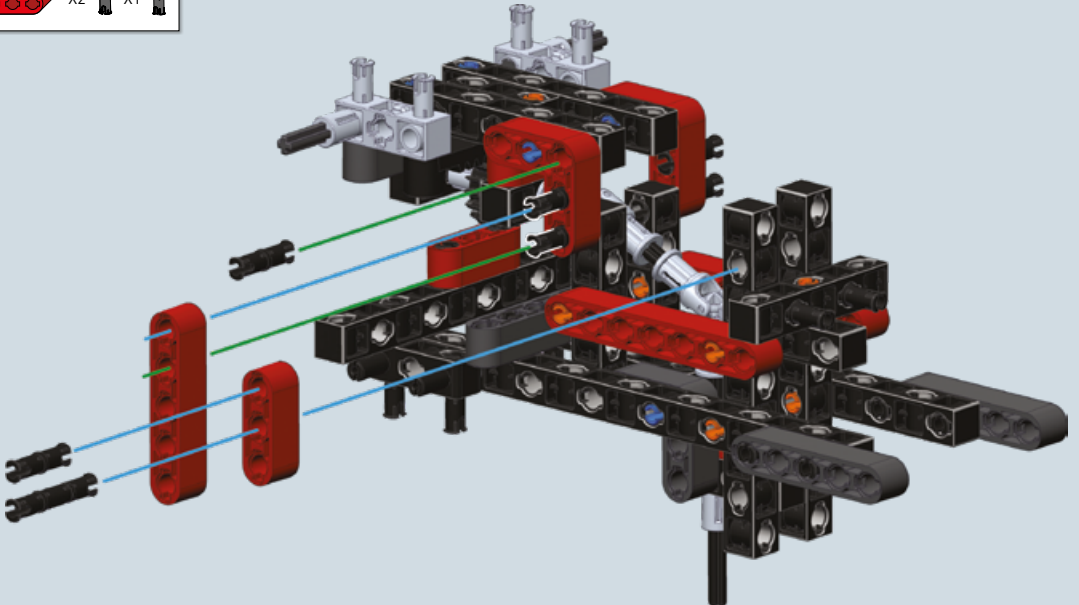

15

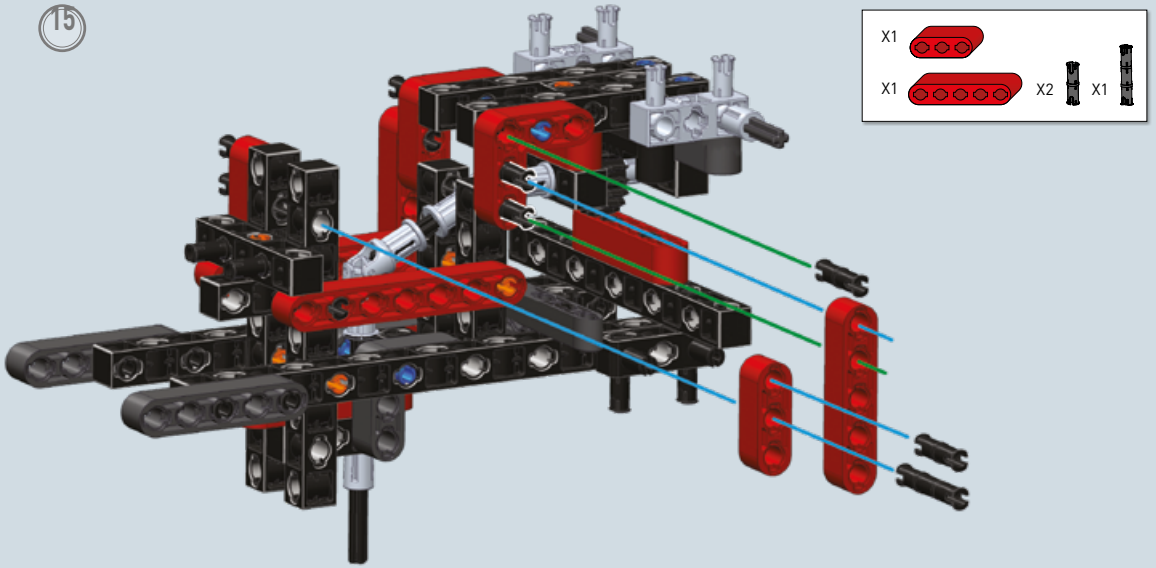

16

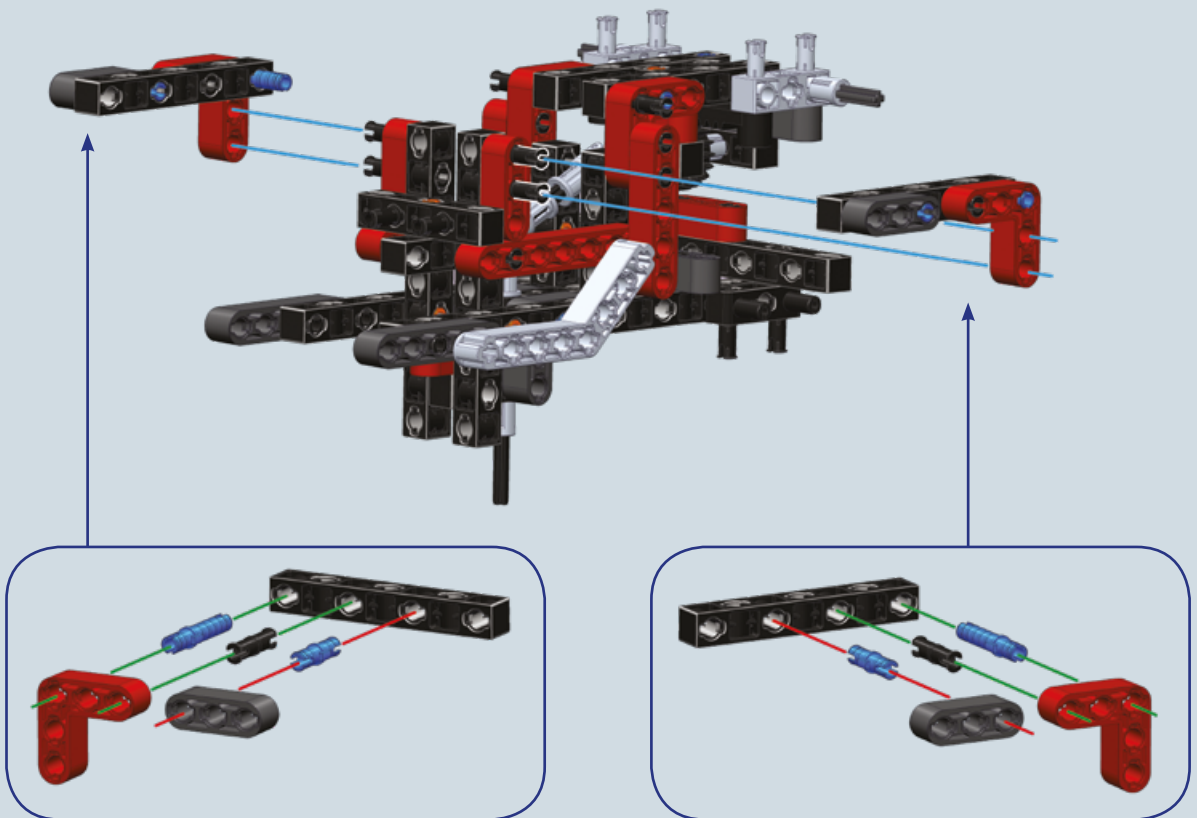
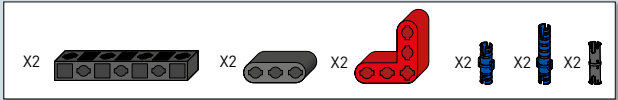

17

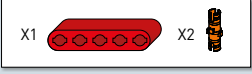
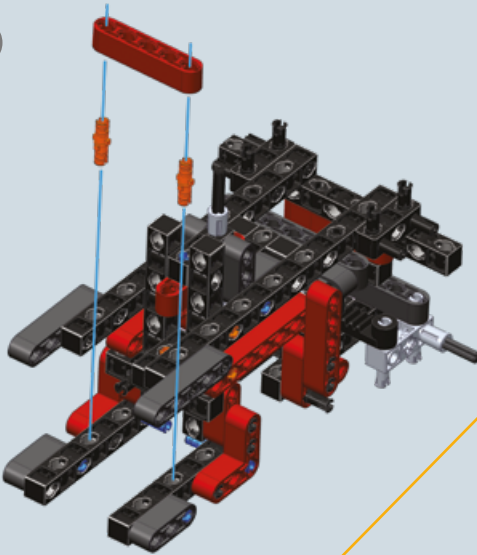

18

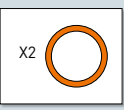
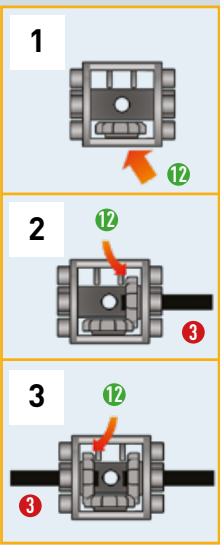
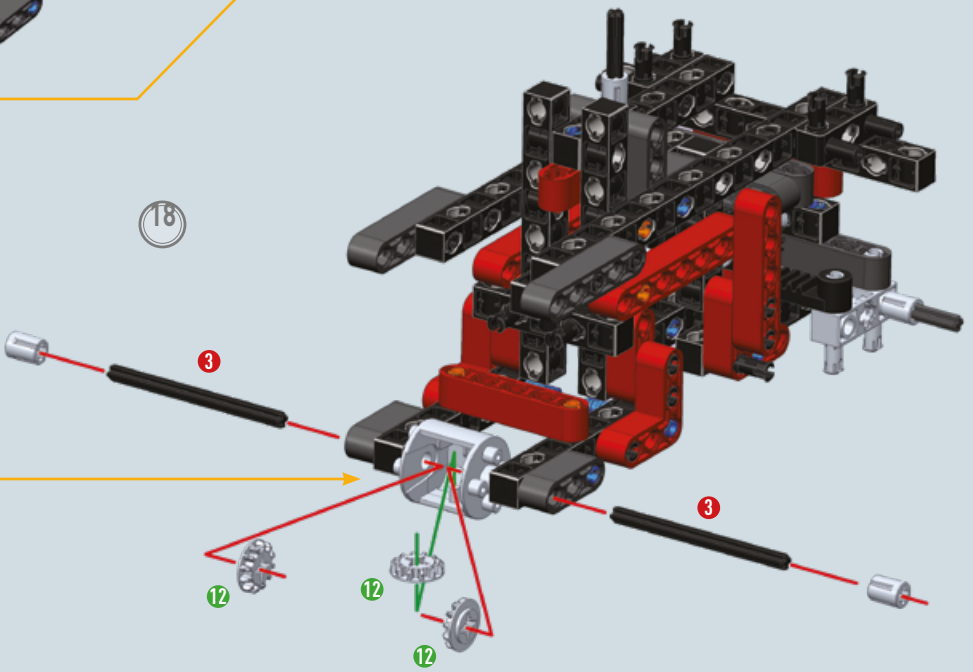

19

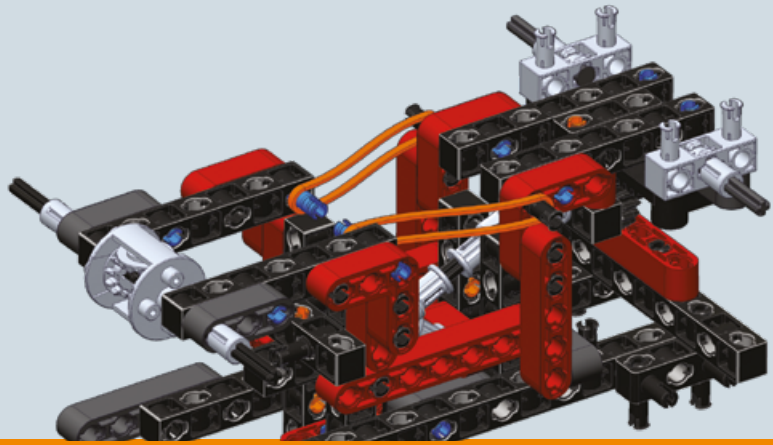

20

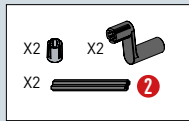
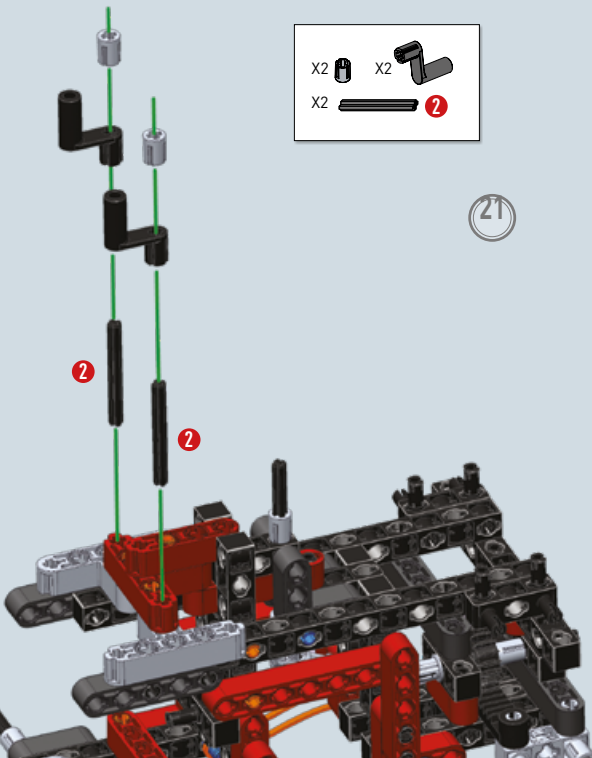
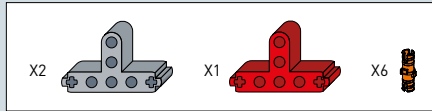
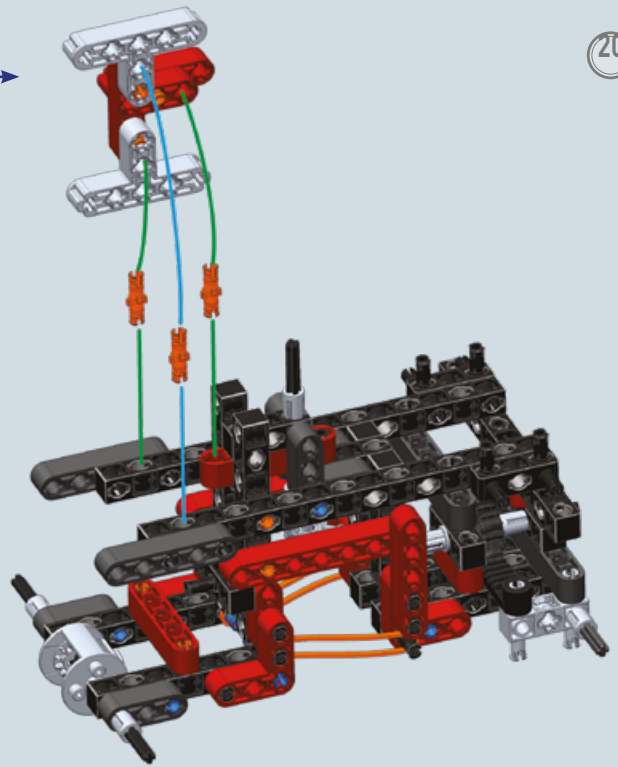
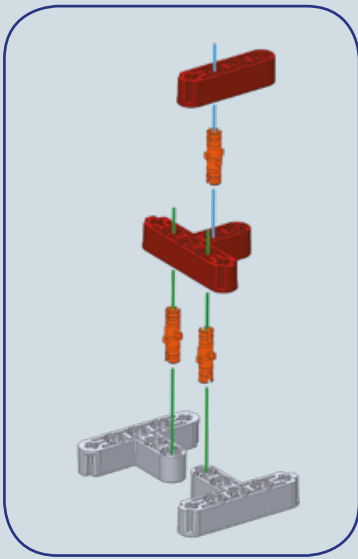

21

22

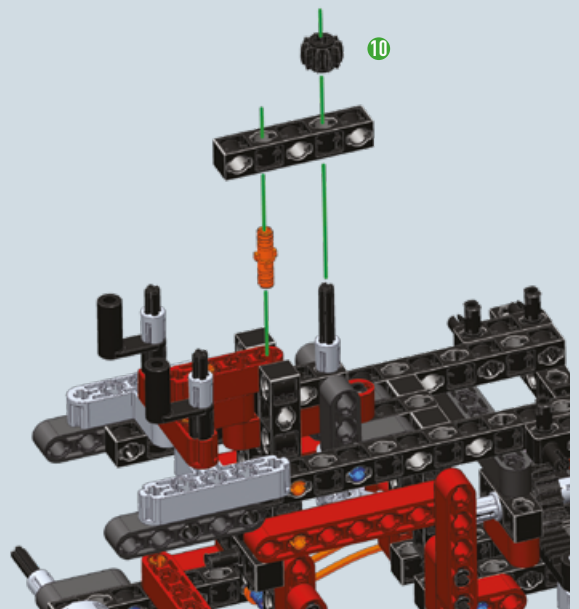
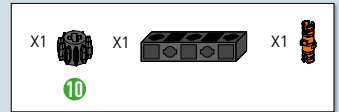

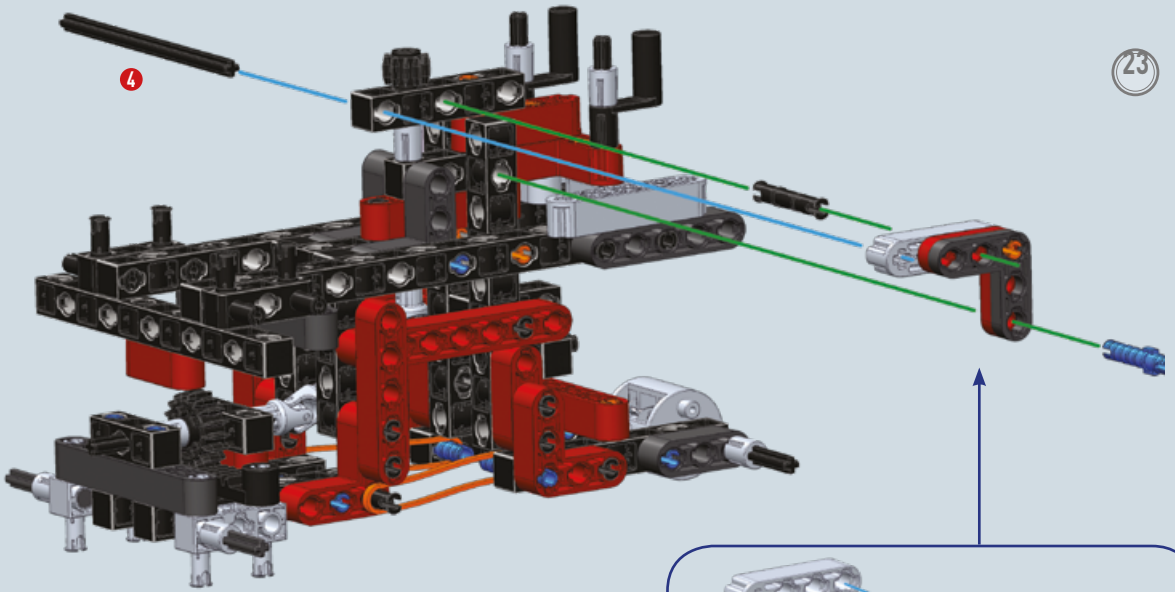

- X1
- X1 X1 X1 X1 X1

1:1

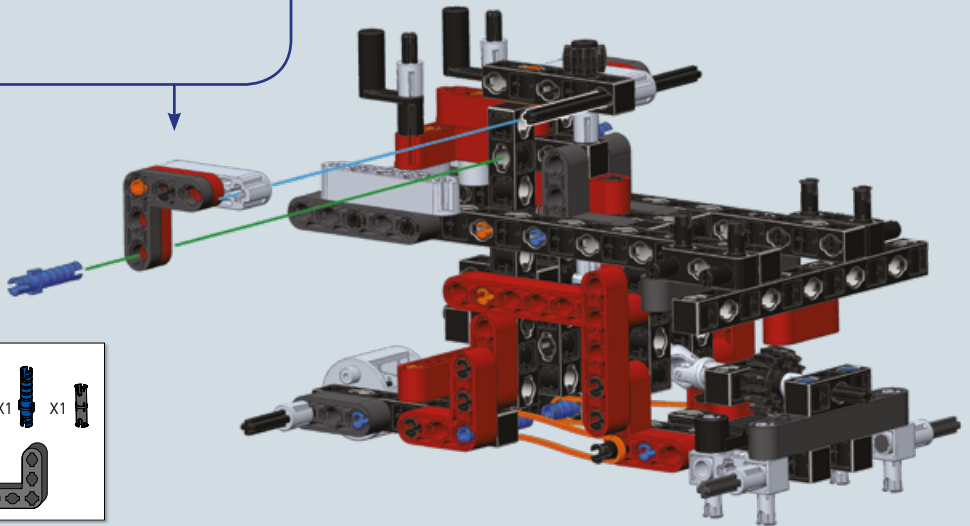
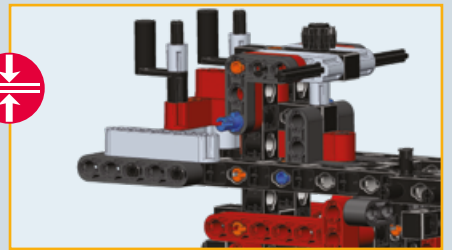
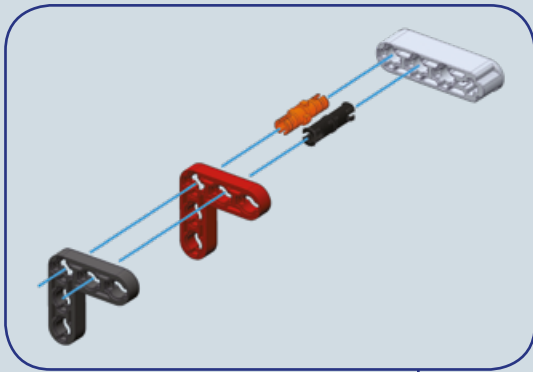
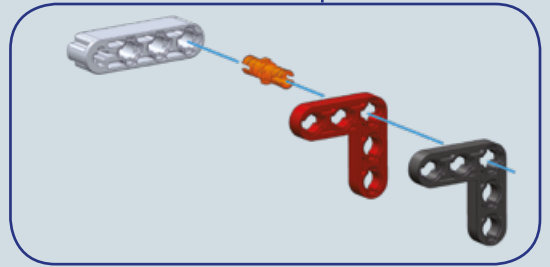

- X1 X1 X1 X1
- X1 X1

25

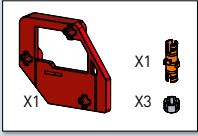
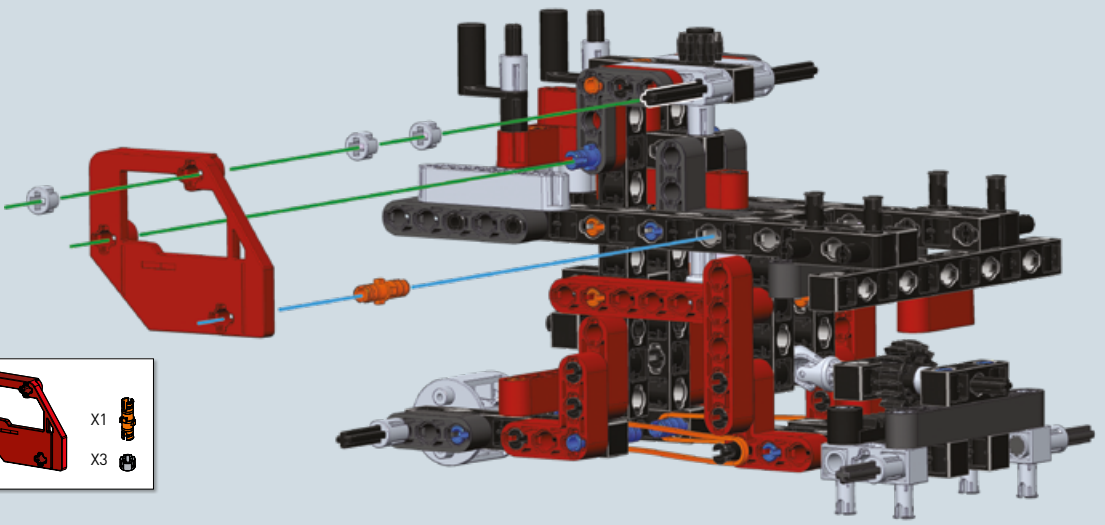

26

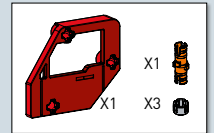
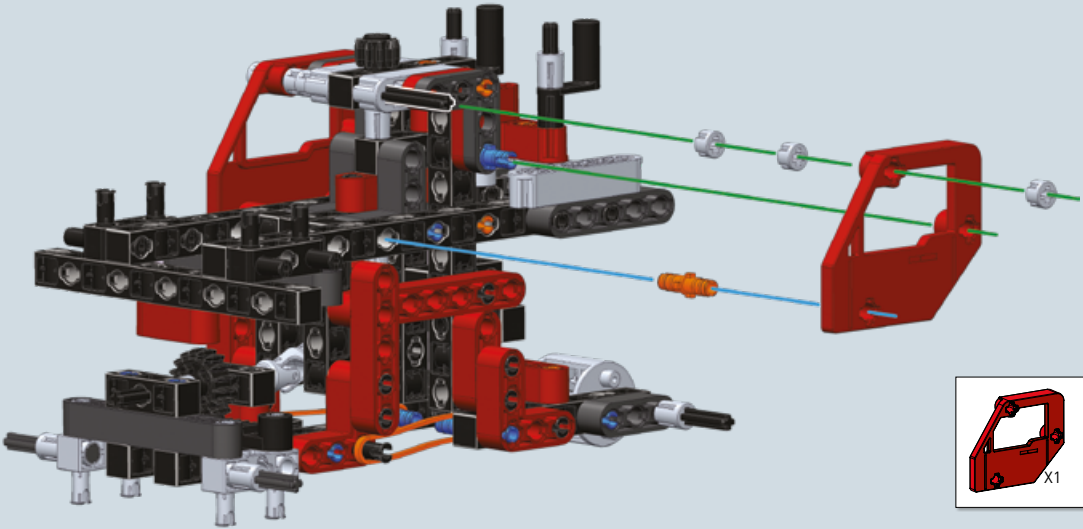

27

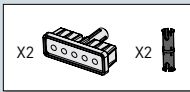
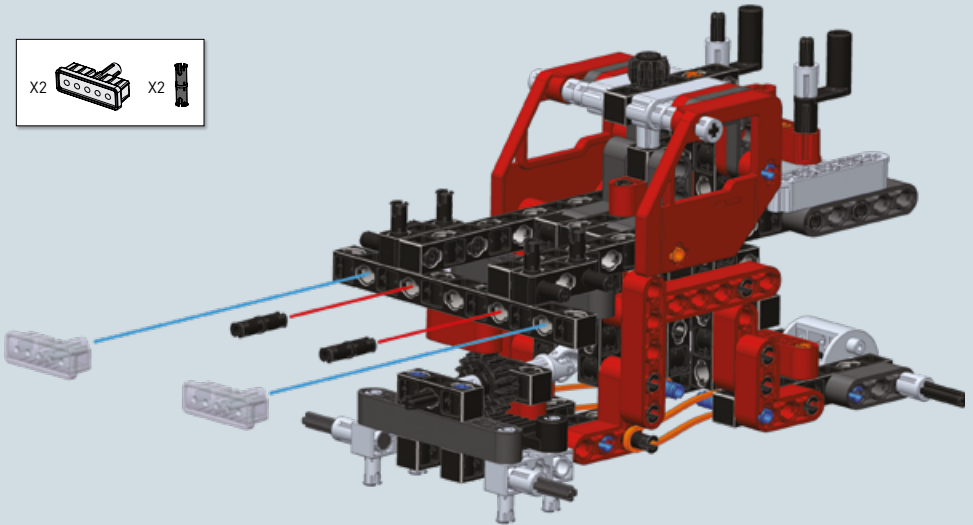

28

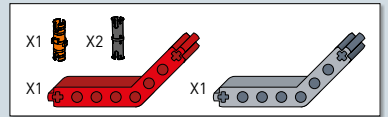
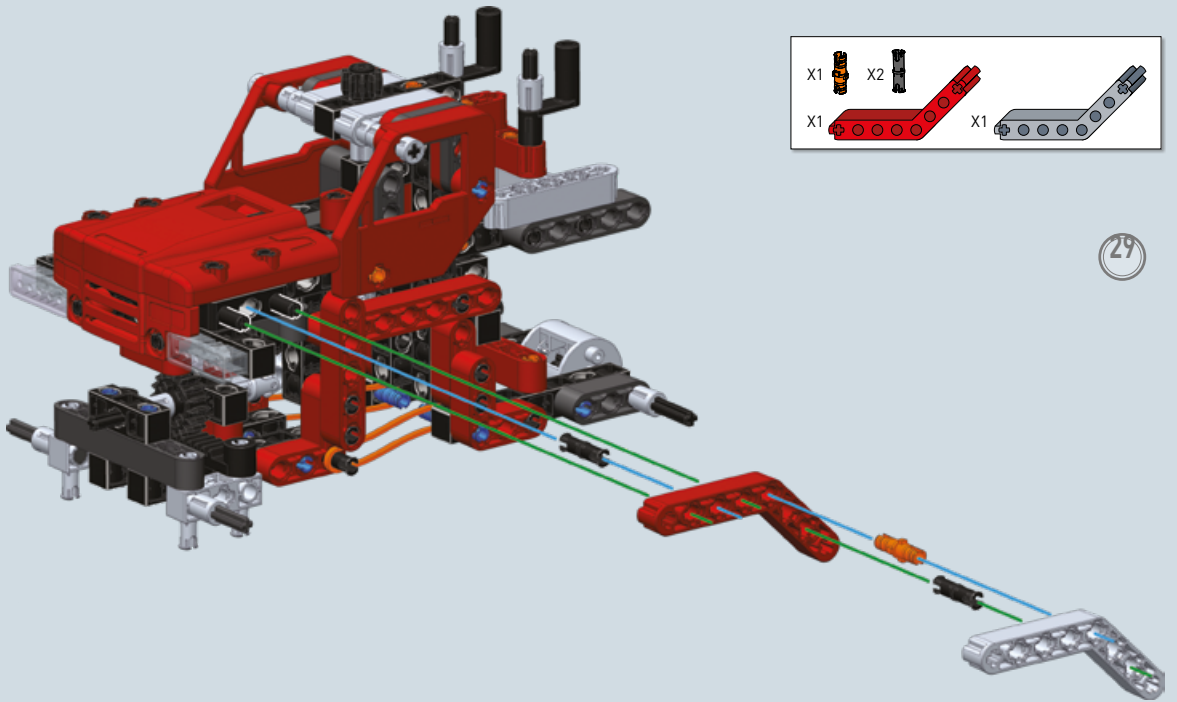
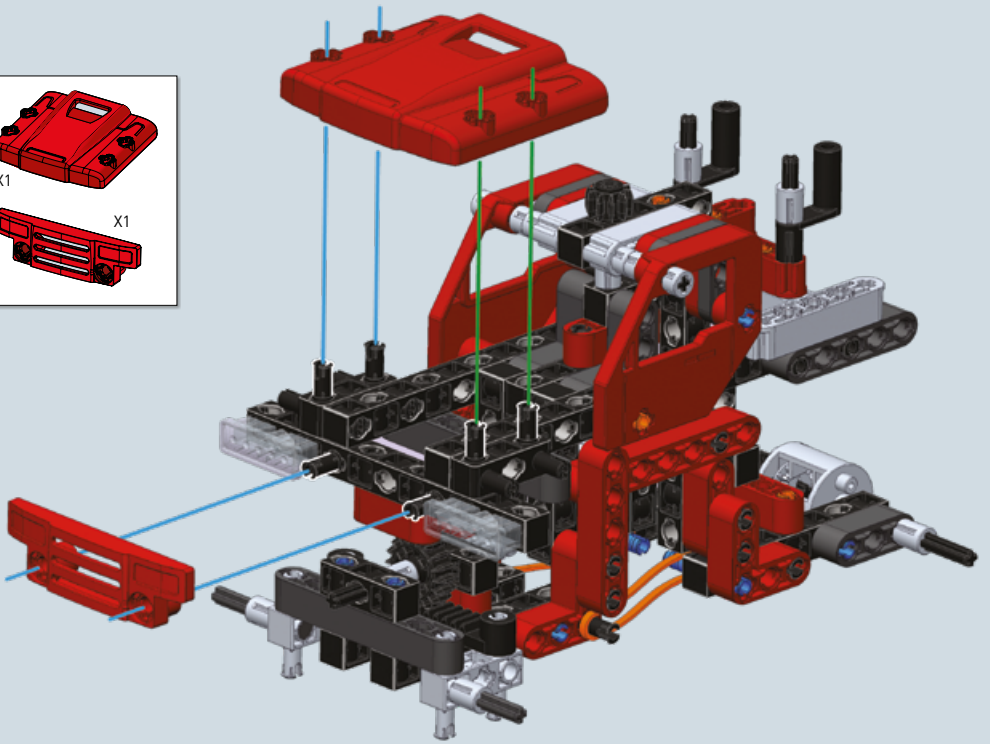
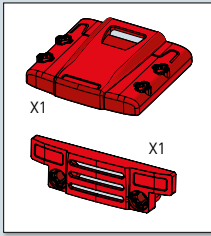

29

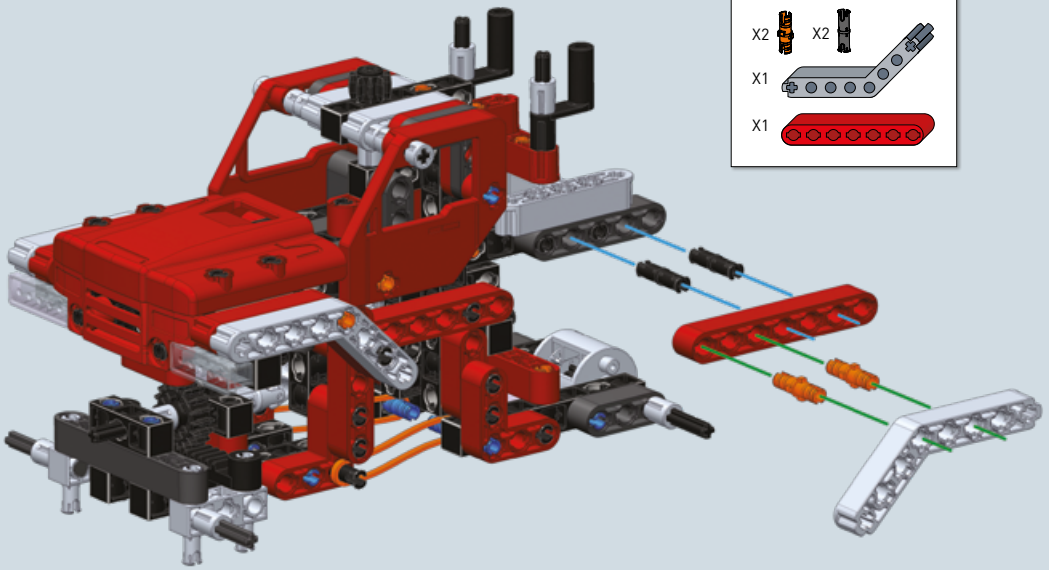

30

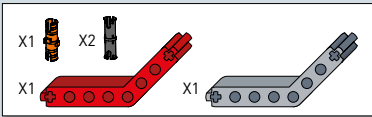

31

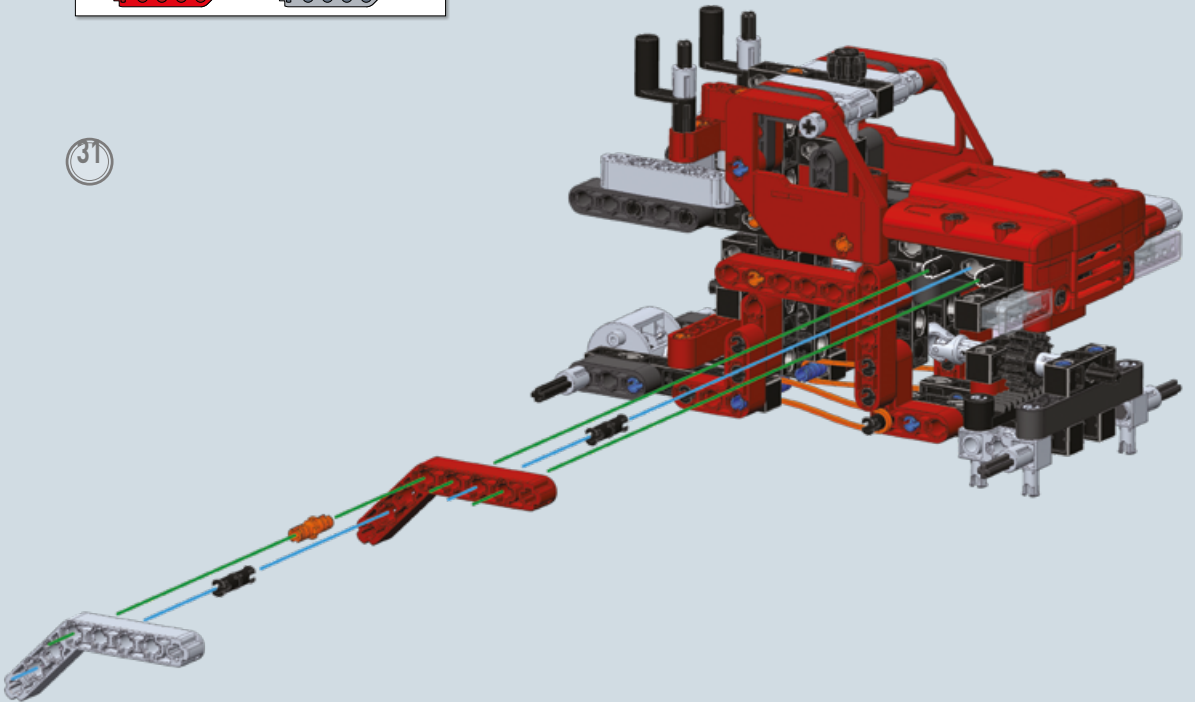

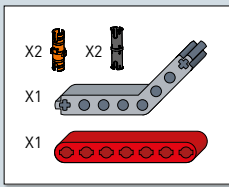

32

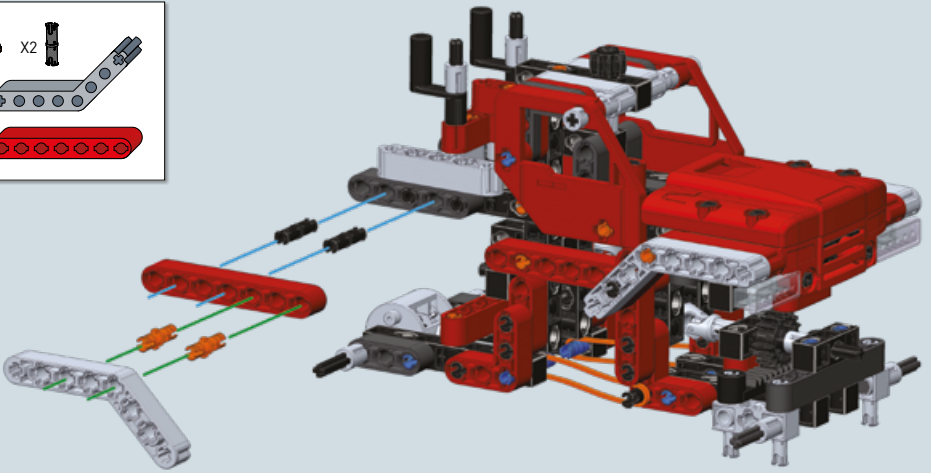

33

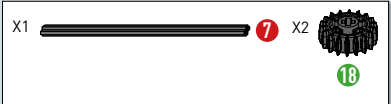
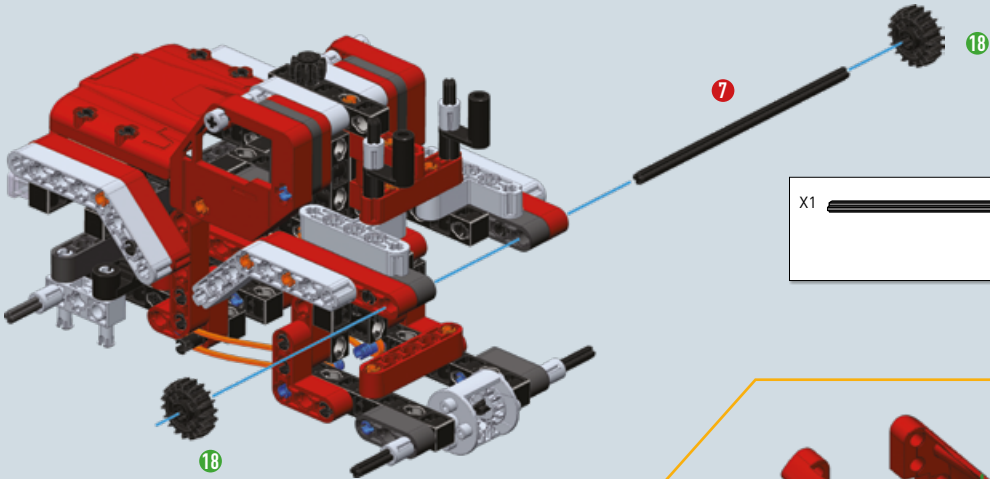

34

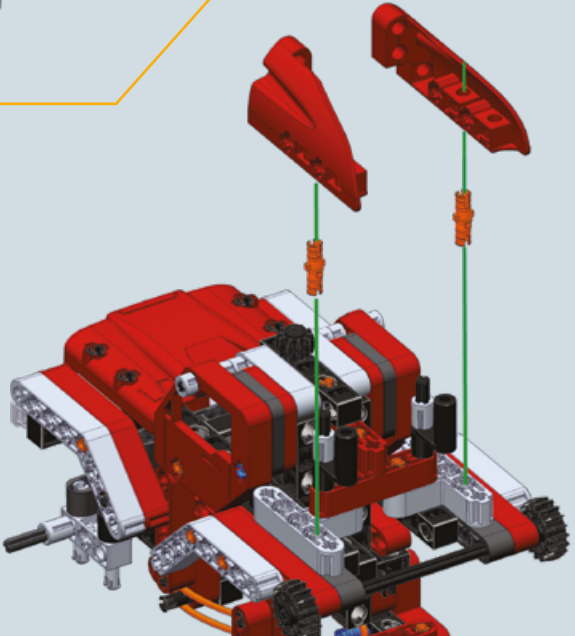
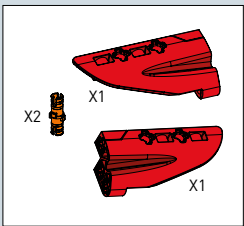

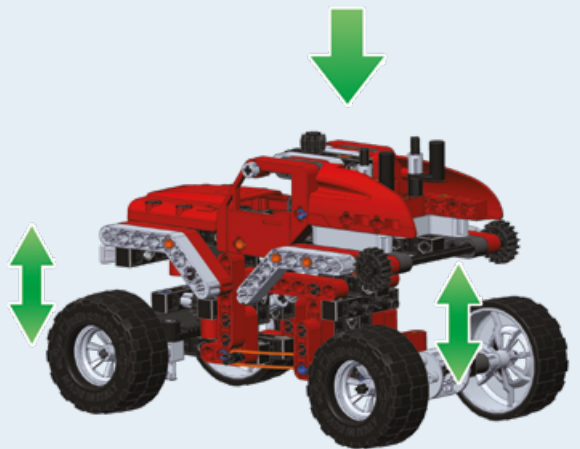
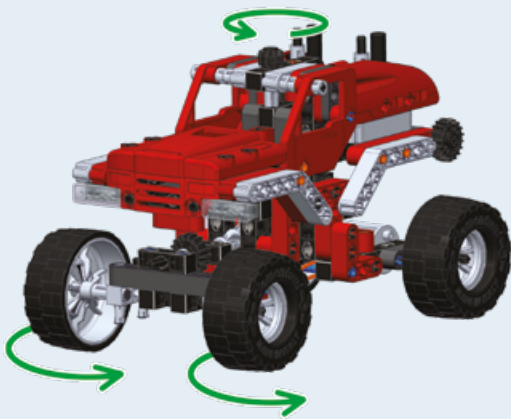
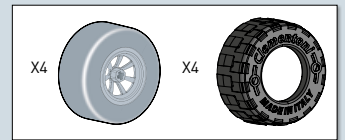
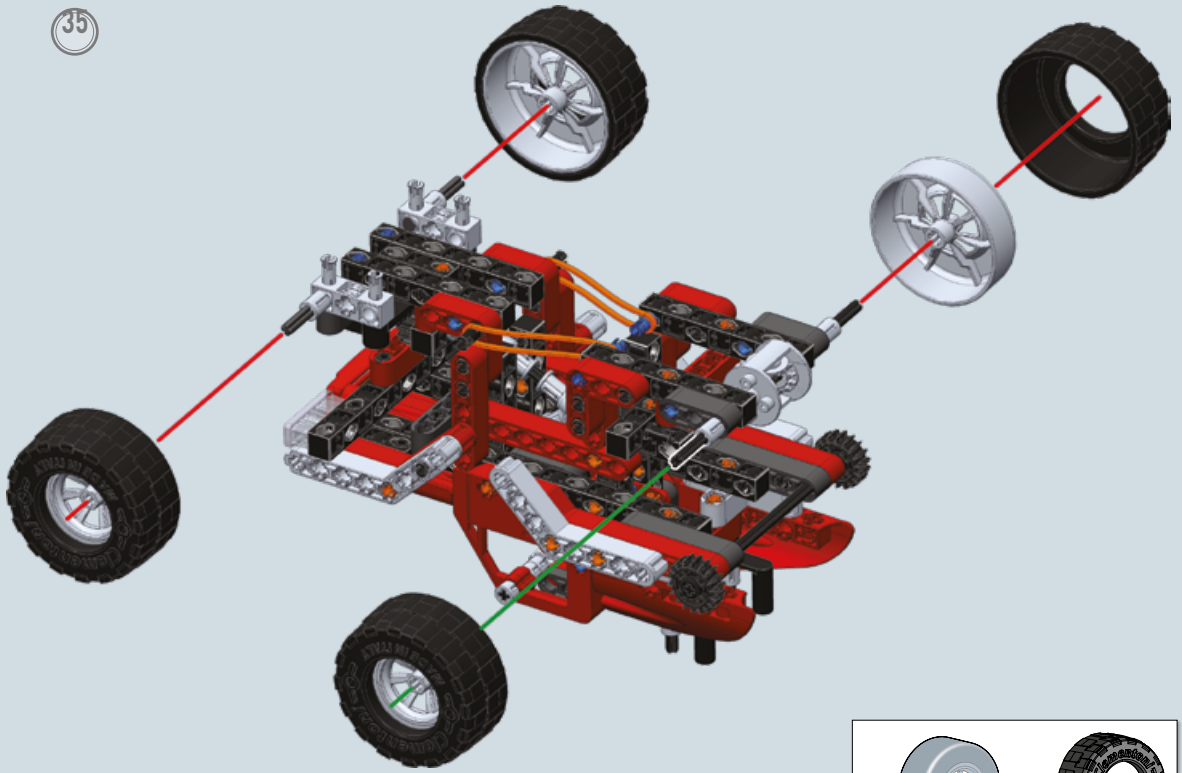

Montaji tamamlanmış model

3 Spider truck



MEKANİK LABORATUVARI
UYGULAMASINDA İNTERAKTİF 3D TALİMATLAR

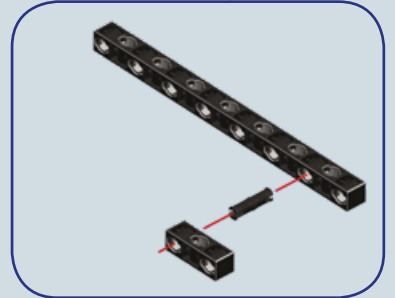
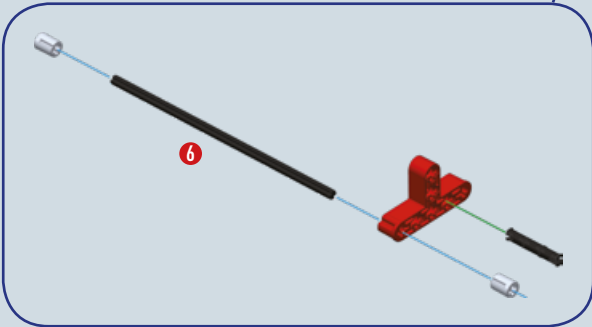
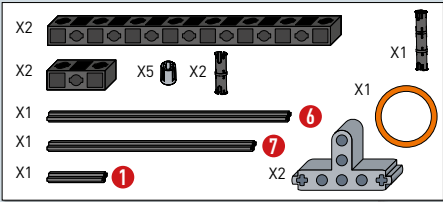
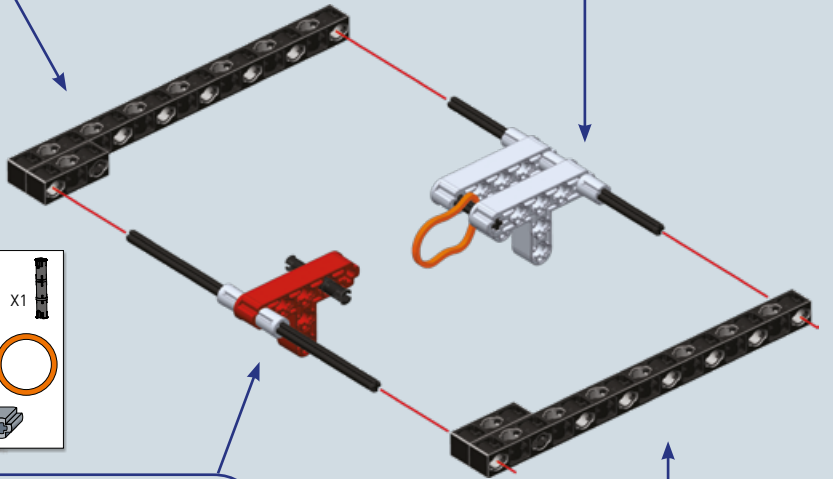
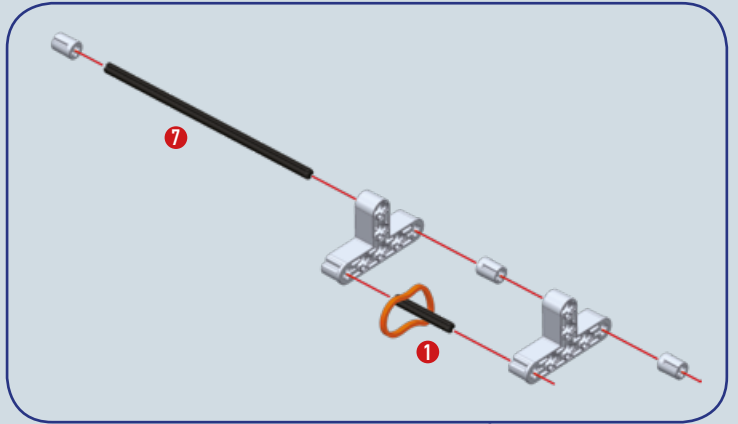
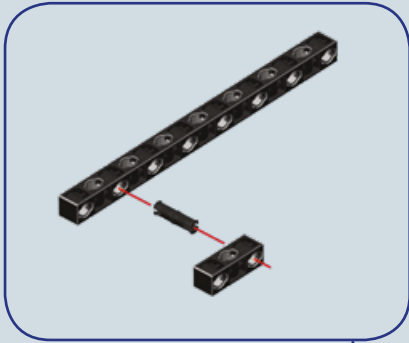

2

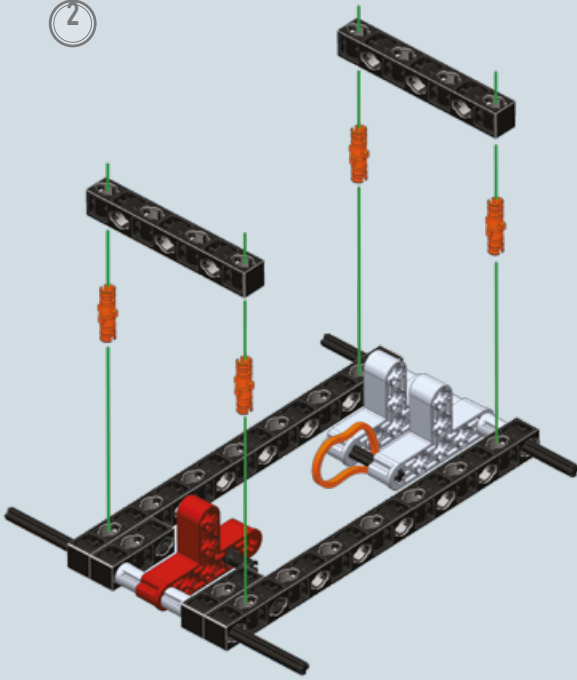

3

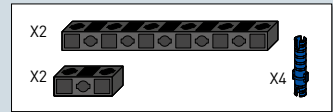
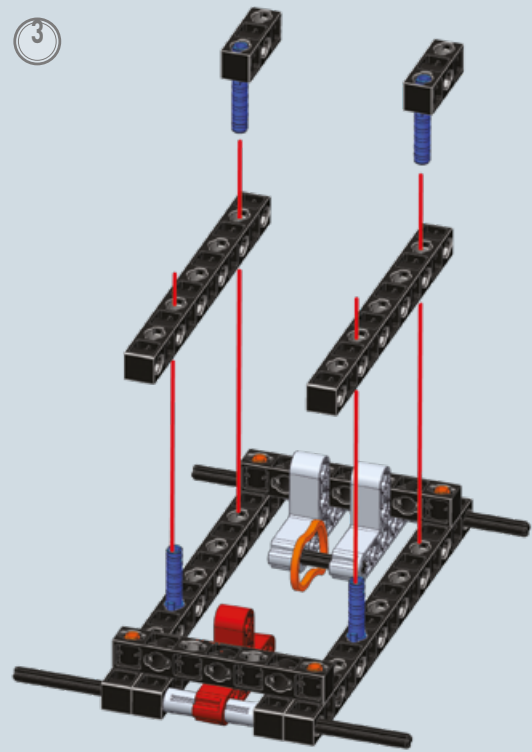

4

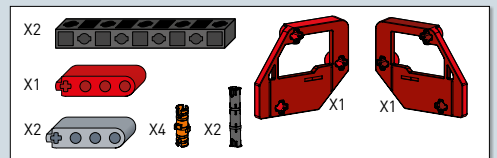
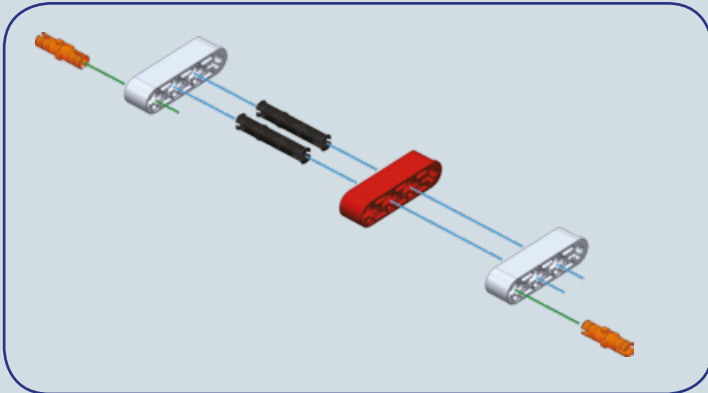
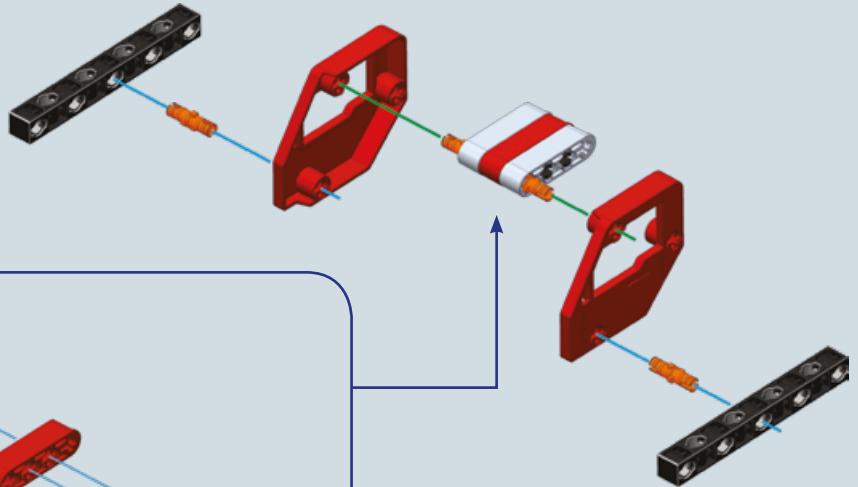

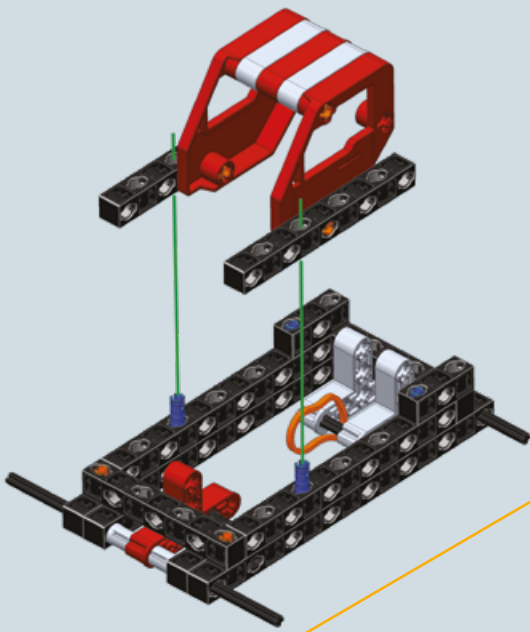

5

6

X1		4
X2		X1

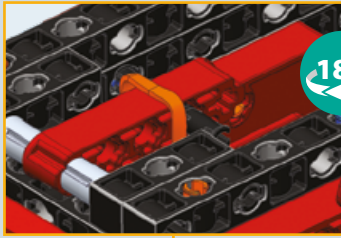

180°

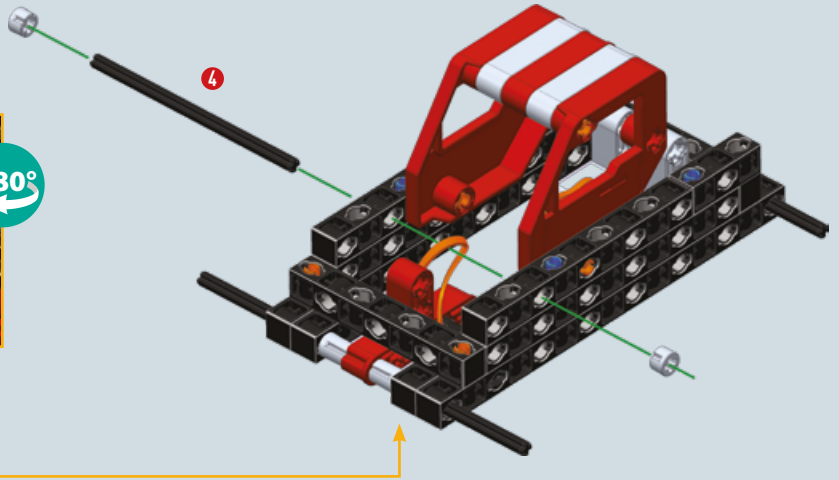

4

7

X2		X3		X1	
----	--	----	--	----	--

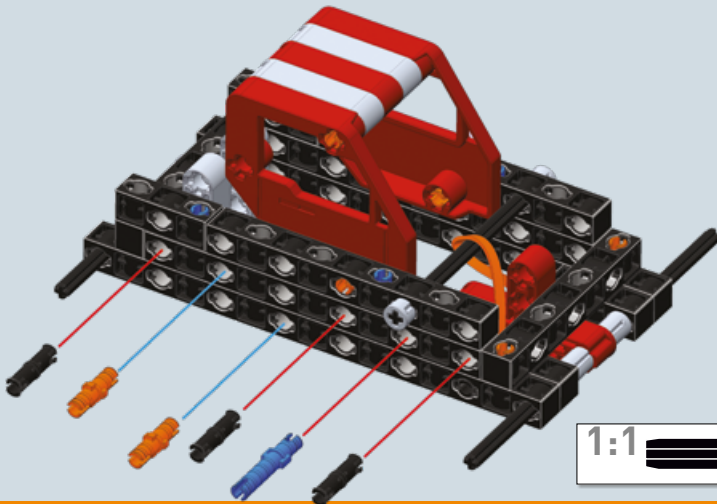

1:1		4
-----	--	---

8

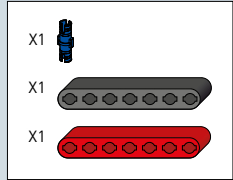
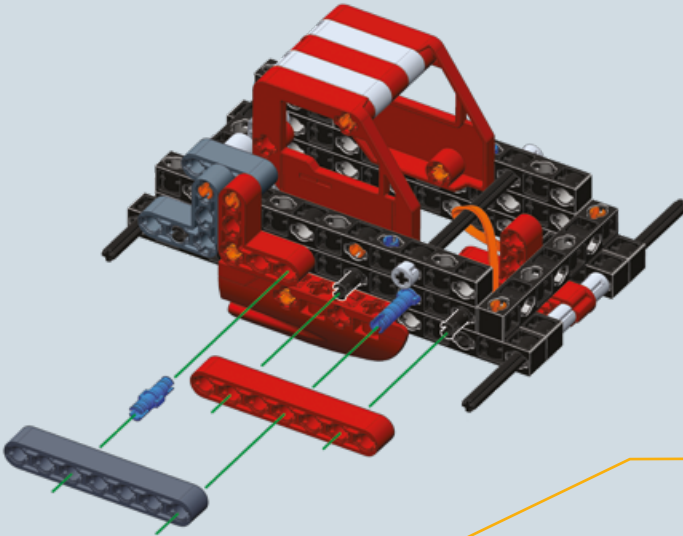
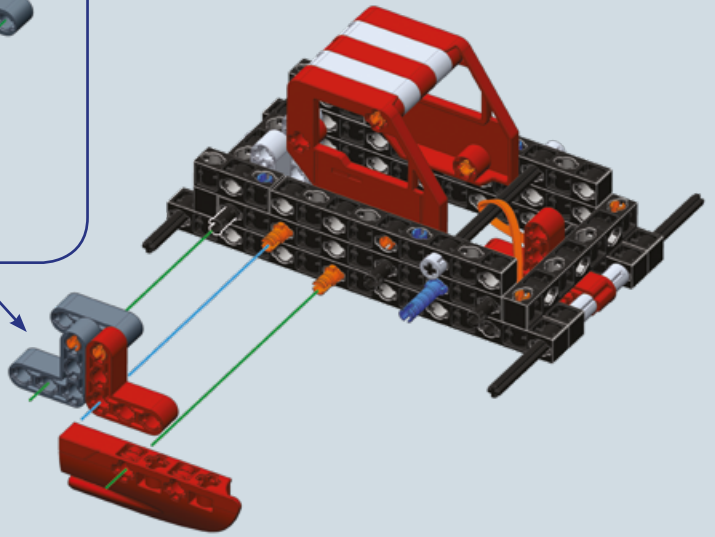
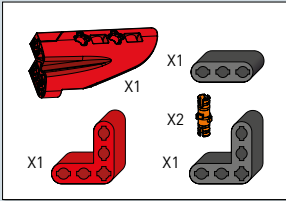
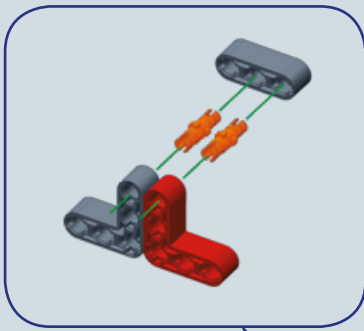

9

10

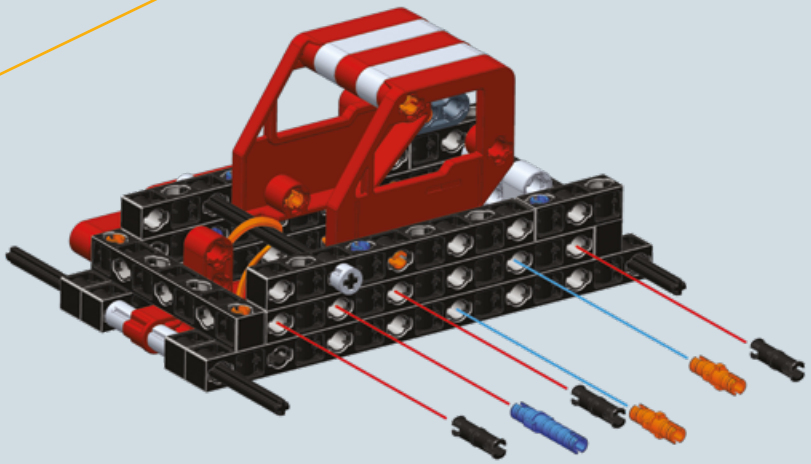
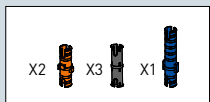

11

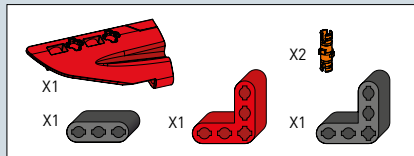
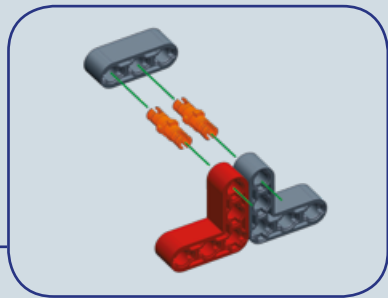
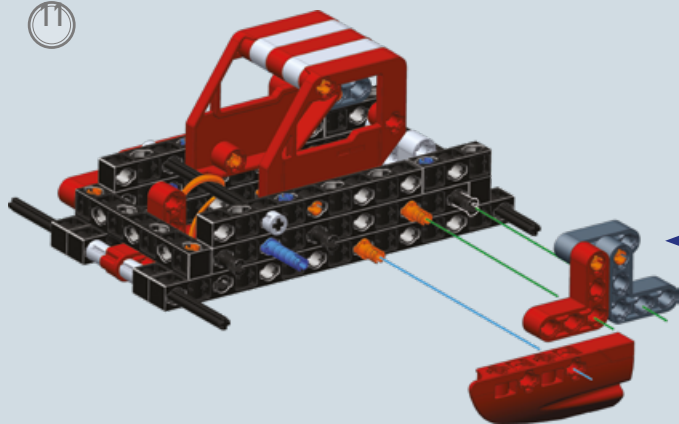

12

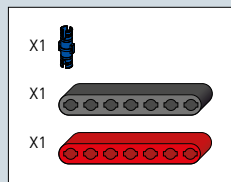
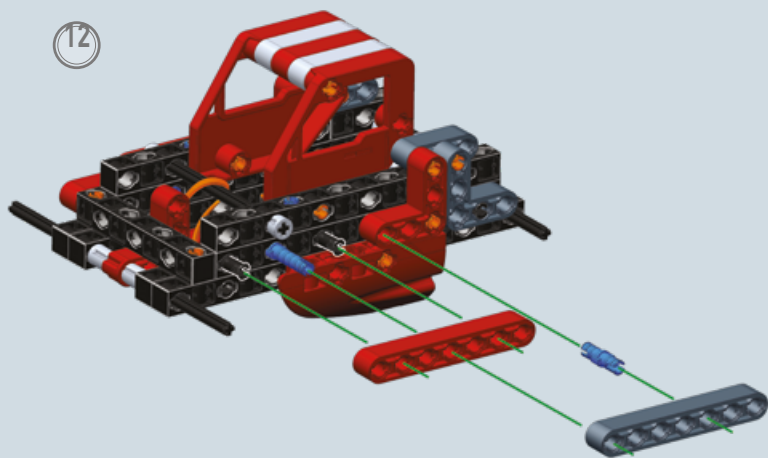

13

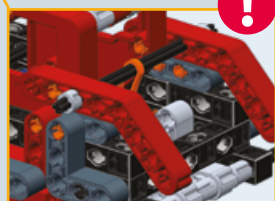
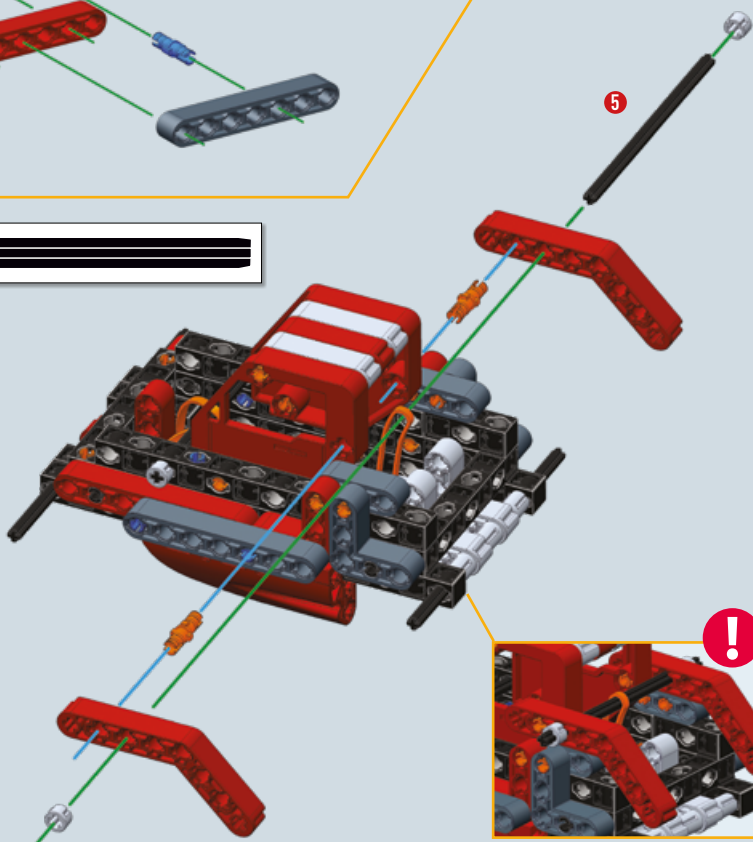
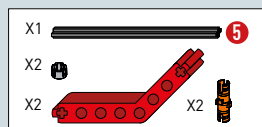

14

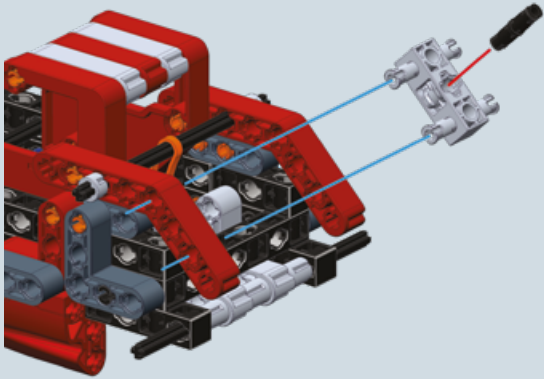
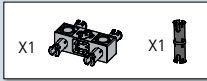

15

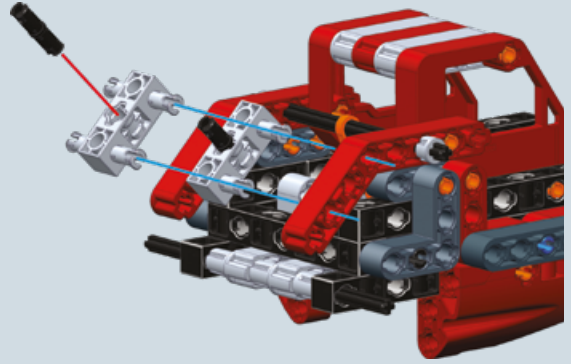
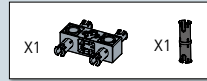

16

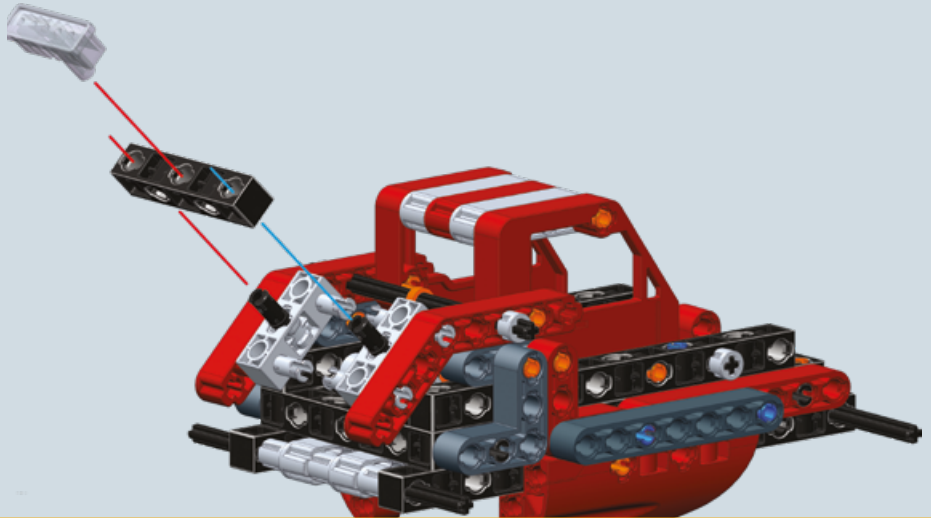
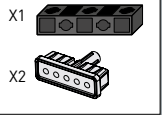

17

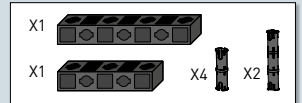
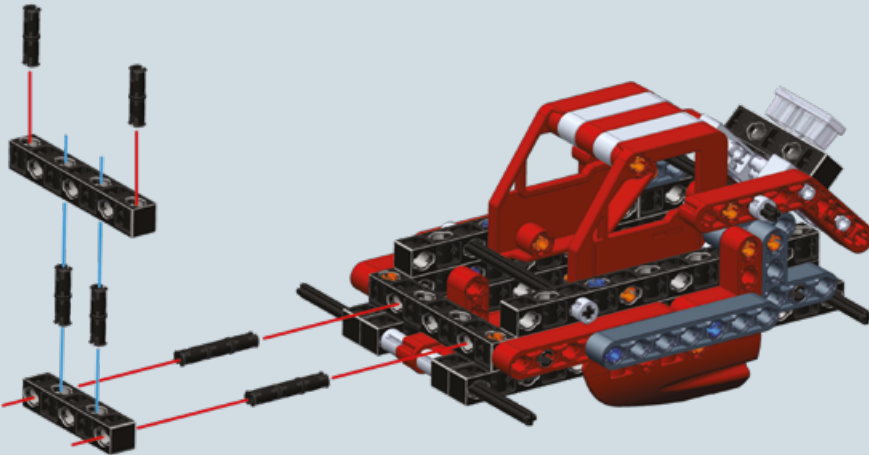

18

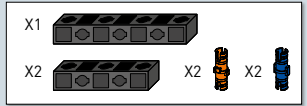
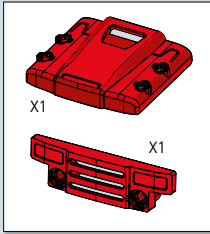
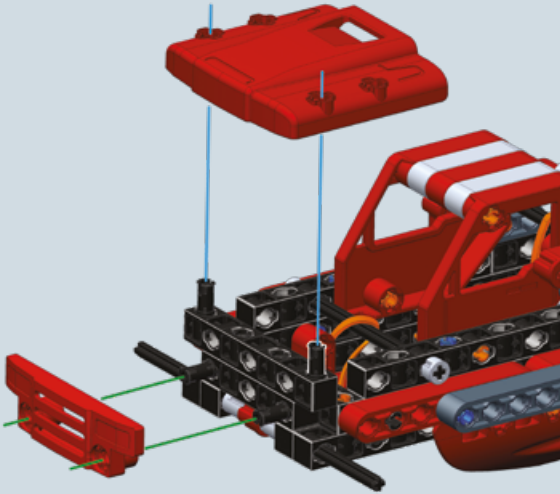

19

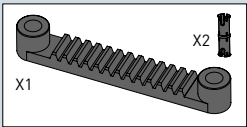
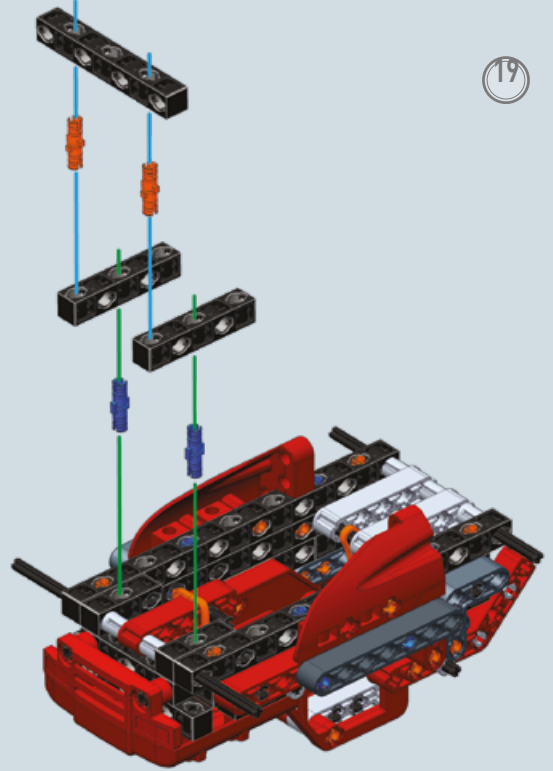

20

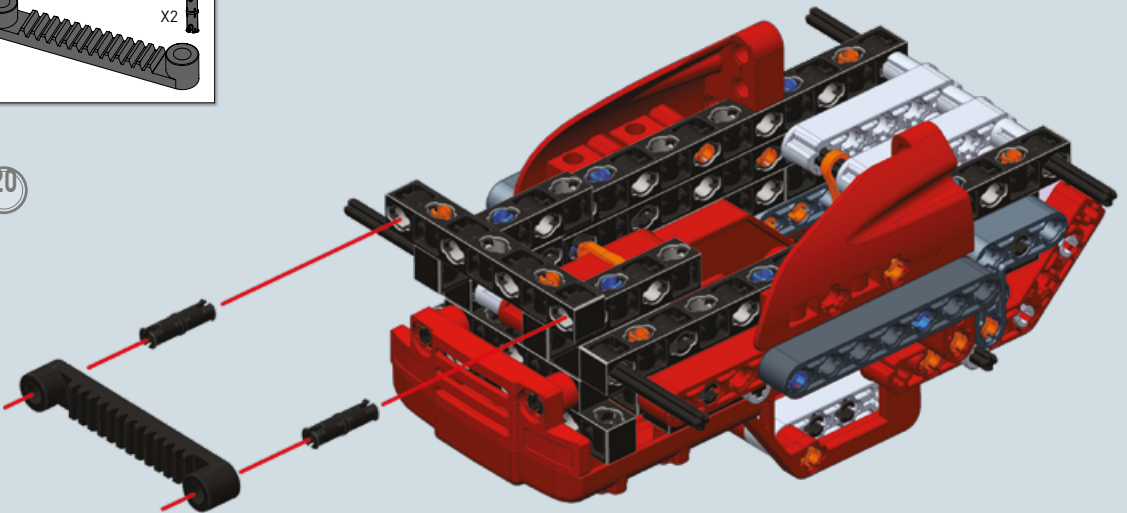

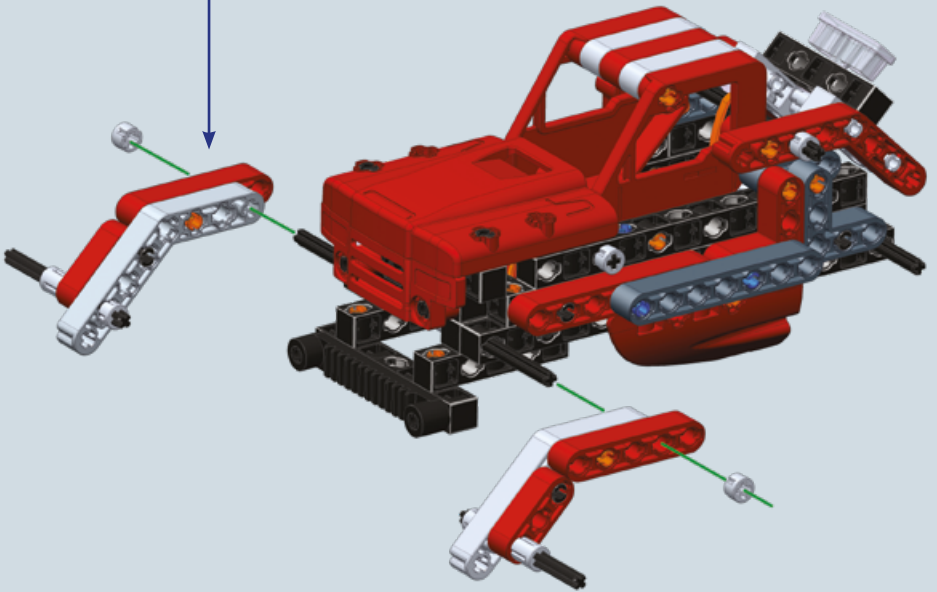
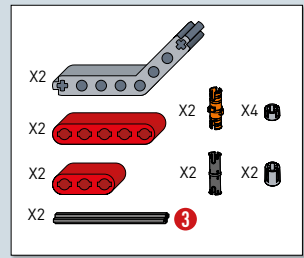
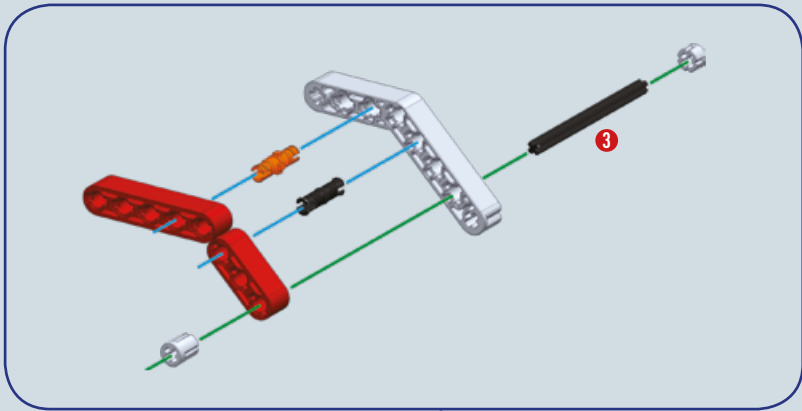

21

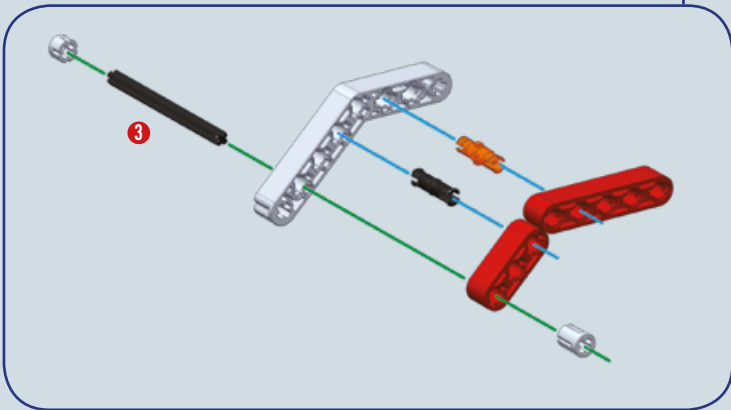

22

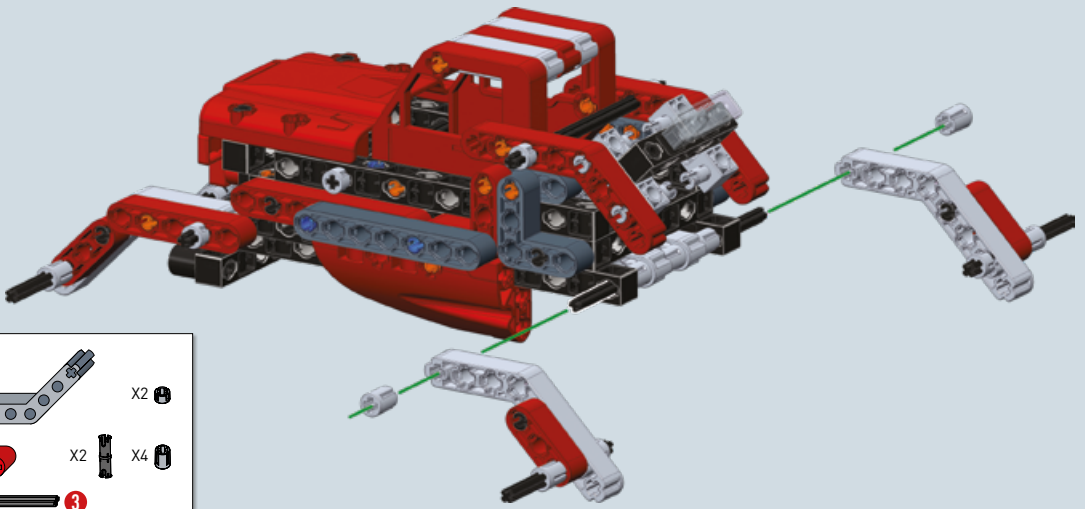

X2		X2	
X2		X2	
X2		X4	

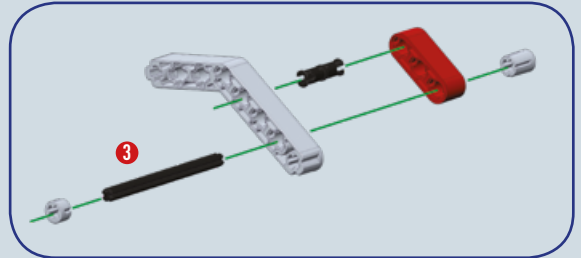
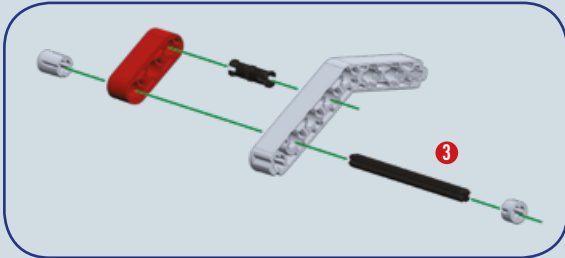

1:1

23

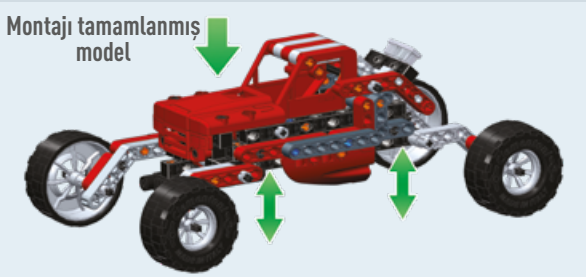
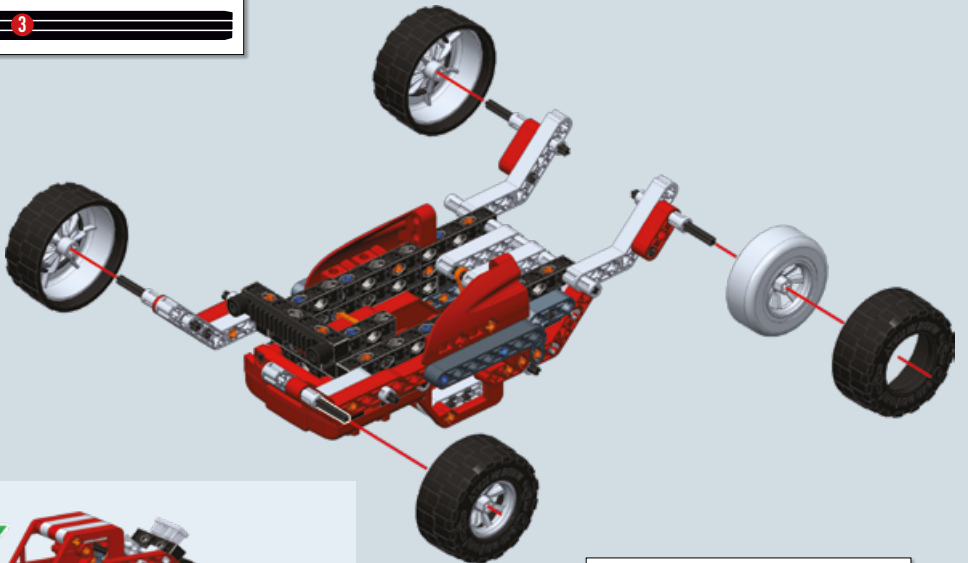

X4		X4	
----	--	----	--

10 HARİKA MODELİ MONTE ETMEK İÇİN ÜCRETSİZ MEKANİK LABORATUVARI UYGULAMASINI İNDİRİN



UYGULAMA aşağıdaki cihazlarla uyumludur:
ANDROID, APPLE ve AMAZON

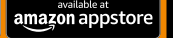

Apple and the Apple logo are trademarks of Apple Inc., registered in the U.S. and other countries. App Store is a service mark of Apple Inc., registered in the U.S. and other countries.

Google Play ve Google Play logosu, Google Inc. şirketinin ticari markalarıdır.

Amazon ve tüm ilgili logolar Amazon.com, Inc. veya bağlı şirketlerinin ticari markalarıdır.

WINDOWS işletim sistemleri ile
UYUMLU DEĞİLDİR.

İTERAKTİF ANİMASYONLAR, MONTAJ İŞLEMLERİNİ BASİT VE HIZLI BİR ŞEKİLDE YAPMANIZ İÇİN SİZİ YÖNLENDİRİR

