

**bilim  
ve oyun**

**TECHNOLOGIC**

# MEKANİK Laboratuvarı KAMYONLAR

**1'den 10'a kadar  
modellerin montajları**

- 1 - Diferansiyelin çalışma prensibi
- 2 - Antika kamyon
- 3 - Maden kamyonu
- 4 - Avrupa kamyonu
- 5 - Kısaç kepçeli kamyon
- 6 - Damperli kamyon
- 7 - Çekici kamyon
- 8 - Vinçli kamyon
- 9 - Kar temizleyici
- 10 - Amerikan kamyonu



V42510

Üretici Firma  
**Clementoni S.p.A.**  
Clementoni tarafından ithal edilmiştir.  
Clementoni Oyuncak San. ve Tic. Ltd. Şti.  
Küçükkalkköy Mh. Tevfik Fikret Cd.  
No:28/67 34750 Ataşehir / İstanbul  
Tel: 0216 574 93 31

Zona Industriale Fontenoce s.n.c.  
62019 Recanati (MC) - Italy  
Tel.: +39 071 75811  
www.clementoni.com

Kullanım kılavuzunu ileride başvurmak üzere saklayınız.

 **Clementoni®**

# PARÇA LİSTESİ

	15 delikli çift kiriş	2 adet
	11 delikli çift kiriş	2 adet
	9 delikli çift kiriş	2 adet
	7 delikli çift kiriş	6 adet
	5 delikli çift kiriş	6 adet
	3 delikli çift kiriş	6 adet
	15 delikli teklî kiriş	2 adet
	13 delikli teklî kiriş	2 adet
	9 delikli teklî kiriş	2 adet
	7 delikli teklî kiriş	2 adet
	5 delikli teklî kiriş	2 adet
	3 delikli teklî kiriş	2 adet
	Uzun L şekilli kiriş	2 adet
	Kısa L şekilli kiriş	2 adet
	4 delikli çift kiriş	2 adet
	T şekilli kiriş	2 adet
	L şekilli kiriş	4 adet
	Mil 7 uzunluk: 9,9 cm	1 adet
	Mil 6 uzunluk: 11,7 cm	1 adet
	Mil 5 uzunluk: 8,1 cm	1 adet
	Mil 4 uzunluk: 7,2 cm	1 adet
	Mil 3 uzunluk: 5,4 cm	5 adet
	Mil 2 uzunluk: 3,6 cm	2 adet
	Mil 1 uzunluk: 2,7 cm	1 adet

	Kısa manşon	12 adet
	Uzun manşon	12 adet
	Sonsuz vida	1 adet
	Diferansiyel kovanı	1 adet
	32 dişli çark	1 adet
	24 dişli çark	1 adet
	12 dişli çark	9 adet
	Kısa çiftli köprü	16 adet
	Kısa teklî köprü	8 adet
	Kısa serbest köprü	32 adet
	Uzun çiftli köprü	8 adet
	Uzun serbest köprü	16 adet
	Köprülü kiriş	4 adet
	Pimli kiriş	6 adet
	Kanca	1 adet
	Döner kol	2 adet
	Kremayer dişli mil	1 adet
	Çivi tipi mil	2 adet

	10 dişli çark	2 adet
	16 dişli çark	5 adet
	26 dişli çark	1 adet
	41 dişli çark	1 adet
	Şanzıman modülü	2 adet
	Tekertelek	4 adet
	8 delikli tekerlek jantı	2 adet
	4 delikli tekerlek jantı	2 adet
	7 delikli teklî kiriş	4 adet
	5 delikli teklî kiriş	4 adet
	3 delikli teklî kiriş	4 adet
	L şekilli uzun kiriş	4 adet
	L şekilli kısa kiriş	4 adet
	Mobil vinç kabini	1 adet
	Sağ el kabin paneli	1 adet
	Sol el kabin paneli	1 adet

İçten yanmalı motor, kimyasal enerjiyi mekanik güce çeviren bir makinedir. Mekanik güç üretebilmek için şunlara ihtiyaç duyarız:

**Yakıt:** Gaz, benzin veya dizel

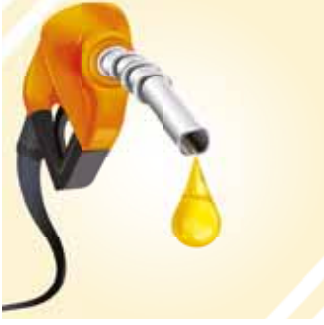

**Oksitleyici madde:** Oksijen

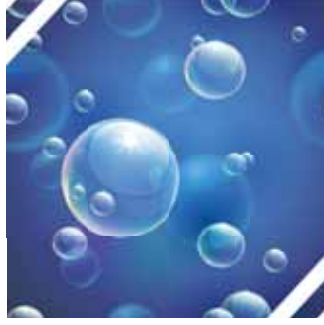

**Yanma odası:** Yakıt ve oksitleyici madde arasındaki yanma tepkimesinin gerçekleştiği bölme.

VANA

KANAL

PİSTON

SİLİNDİR

BAĞLANTI ÇUBUĞU

MOTOR MİLİ



**Nasıl çalışır? Yanma 4 aşamada gerçekleşir:**

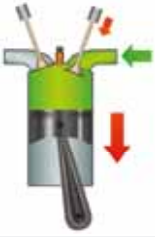

## 1. AŞAMA

**Giriş:**  
Piston iner.  
Hava veya hava/yakıt karışımı silindir tarafından emilir.



## 2. AŞAMA

**Sıkıştırma:**  
Piston yükselir.  
Hava/yakıt karışımı sıkışır.  
Yanma başlar.



## 3. AŞAMA

**Ateşleme ve Genleşme:**  
Piston iner.  
Yanma gerçekleşir ve gazın hemen genişlemesine sebep olur.  
Piston aşağıya doğru iner.



## 4. AŞAMA

**Egzoz:**  
Piston yükselir.  
Yanma artıkları silindirden dışarı atılır.

Açıklanan her bir döngü, motor milinin iki kez dönmesini sağlar. Bu işlem, hareketi aracın diğer mekanik parçalarına yönlendirir.

**Benzinli motor / dizel motor.** Benzinli motor ve dizel motor, ateşleme aşamasında farklılık gösterir:

Buji

## BENZİNLİ MOTOR

Bu, kontrollü ateşlemeli bir motordur. Elektrik yükü sayesinde hava/yakıt karışımı ateşlenir.



Püskürtücü

## DİZEL MOTOR

Bu, içten ateşlemeli bir motordur. Yakıt, silindire yalnızca sıkıştırma aşamasından sonra verilir. Sıkıştırılmış hava, yakıtın ateşleneceği kadar yüksek ısıya ulaşır.



Kamyonlarına, hareketi tamamlamak için hidrolik yağı basıncından yararlanan belirli tahrik düzeneğiyle çalışan ekipmanlar eklenebilir.

Hidrolik piston, iki mekanik parçadan oluşan bir tahrik düzeneğidir:

- boş ve silindir bir gövdeden oluşan silindir
- dolu ve yuvarlak bir gövdeden oluşan piston veya mil



SİLİNDİR

HİDROLİK YAĞ BOŞLUĞU

PİSTON VEYA MİL

**Nasıl çalışır?** Hidrolik piston, çift etkili bir silindirden oluşur. Bu silindir içinde hidrolik yağı, operatör denetiminde iki ucun herhangi birinden verilebilir.

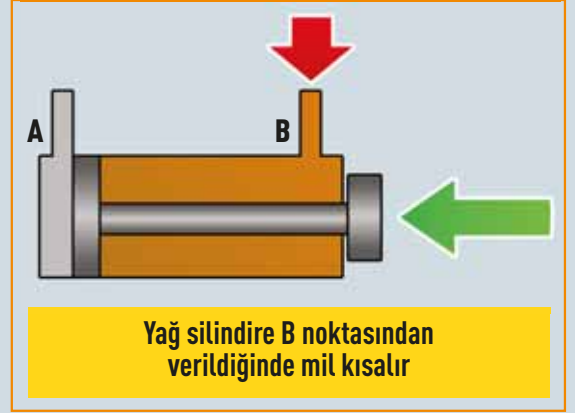
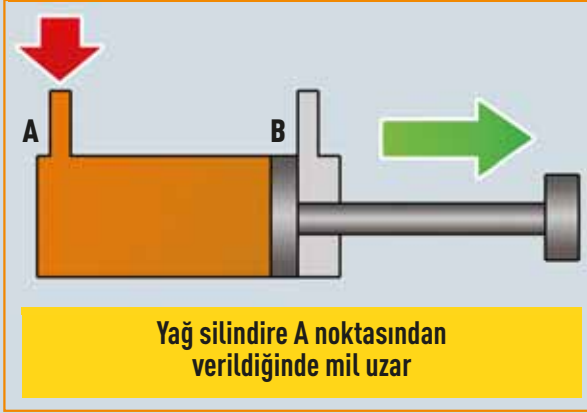

## Hidrolik devre

Hidrolik yağı, kapalı bir devre içinde hareket eder.

Yağ, ilk pompayla depolama tankından çekilir ve dağıtıcıya gönderilir. Dağıtıcı piston için iki erişim yolunu açar ve kapatır, böylece operatör denetiminde mil uzar veya kısalmır. Kapalı devredeki yağ, silindirin bir tarafından itilir ve dağıtıcı üzerinden tanka yeniden tahliye edilir.

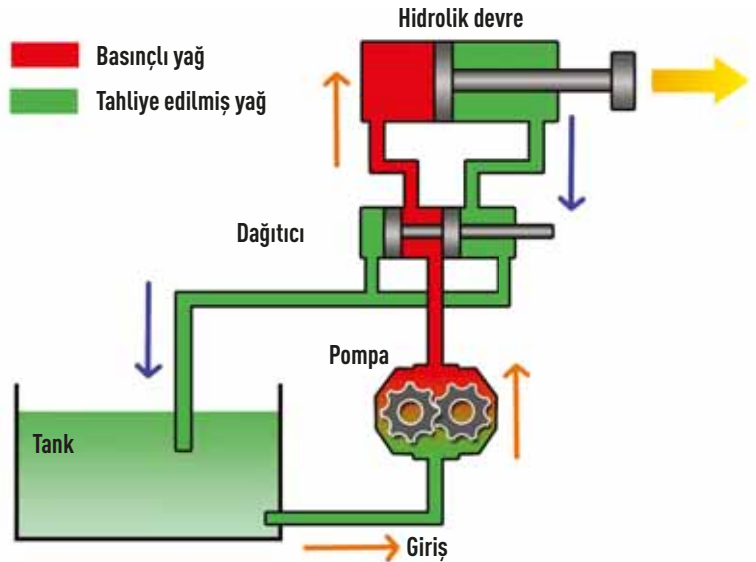



2

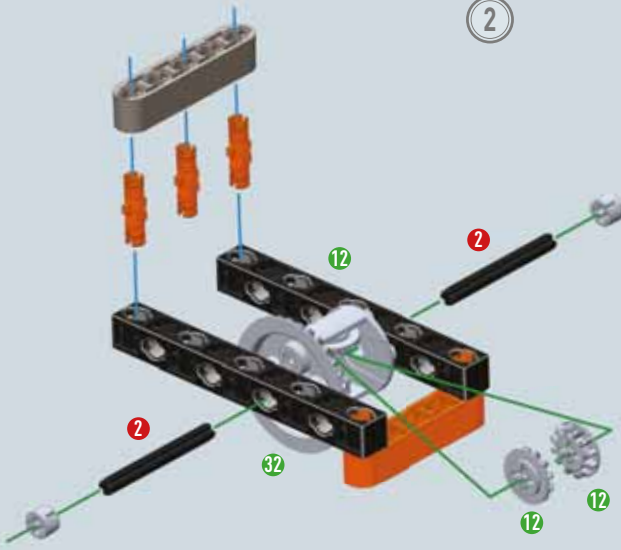

- X1
- X2
- X1
- X3
- X2
- X3

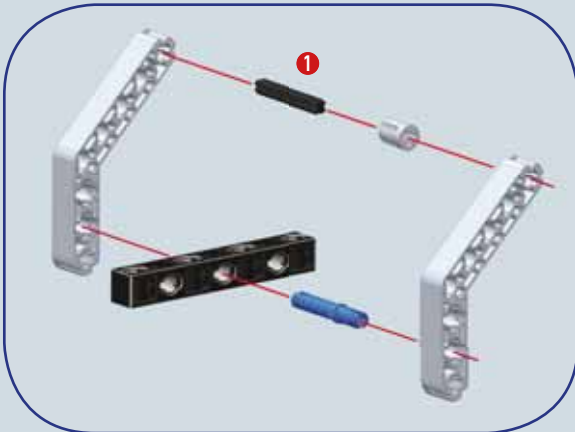
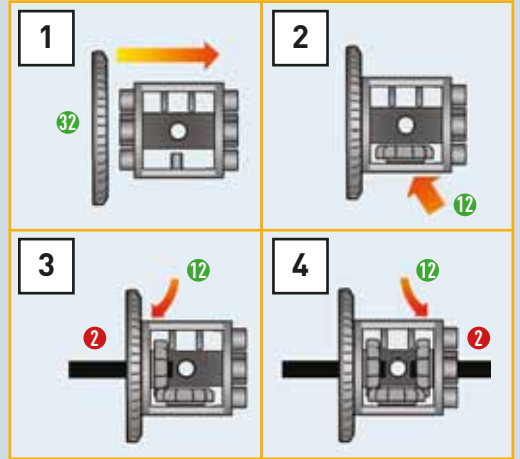

- X1
- X1
- X2
- X1
- X1
- X1
- X1
- X1
- X2
- X2
- X2
- X2

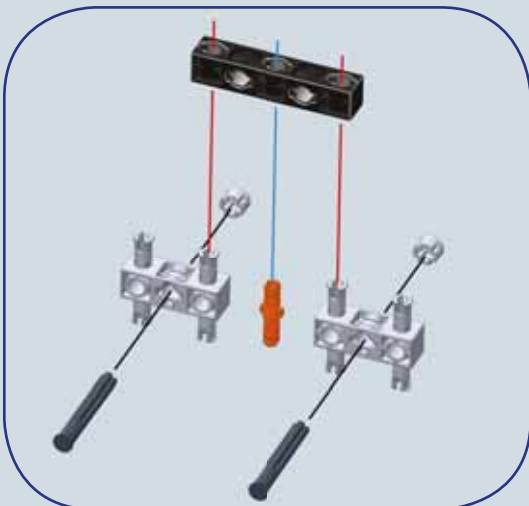

3

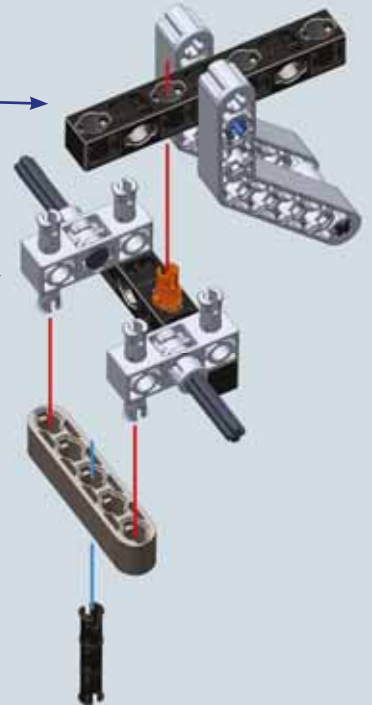

4

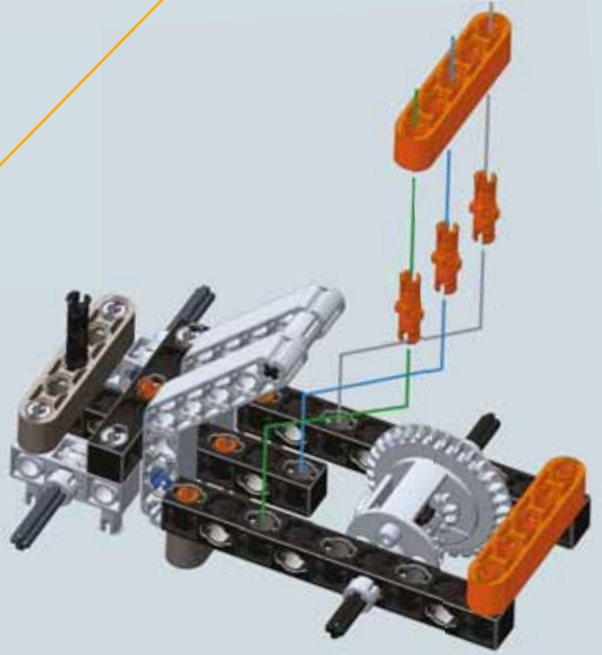
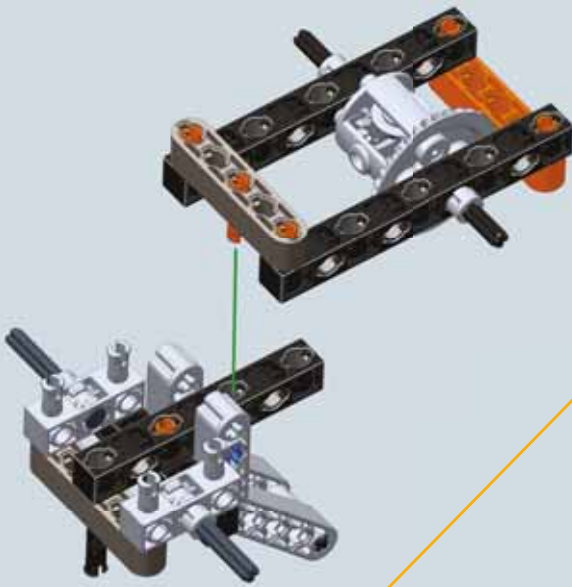

5

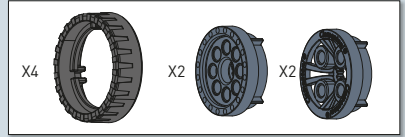
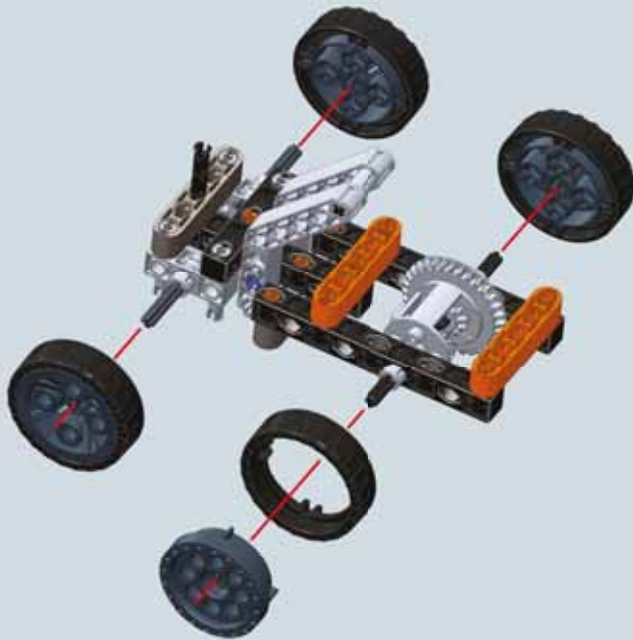
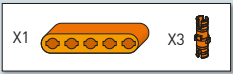

6



Montaji tamamlanmış model



### Teknik unsurlar ve merak edilimler

Tarihte ilk kamyon 1896 yılında üretilmiştir. İlk kamyonun tasarımı oldukça sadeydi ve çağın at arabalarından ilham almıştı: Yük hayvanlarının bağlandığı ve kamyona takılabilen motor sayesinde kaldırılan ön kısım, cihazı 16 km/sa hızla hareket ettirebiliyordu. Tekerleklerin ana malzemesi ahşaptı, dış jant metalden üretilmişti. Fren sistemi, at arabalarında kullanılan sistemle aynıydı.

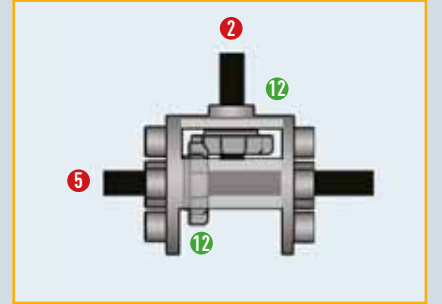
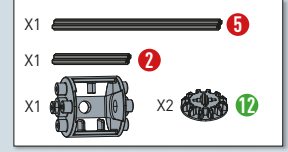
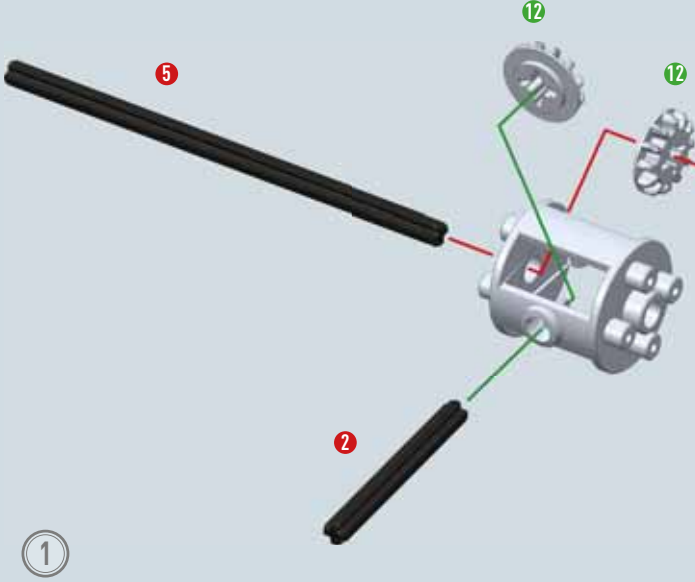



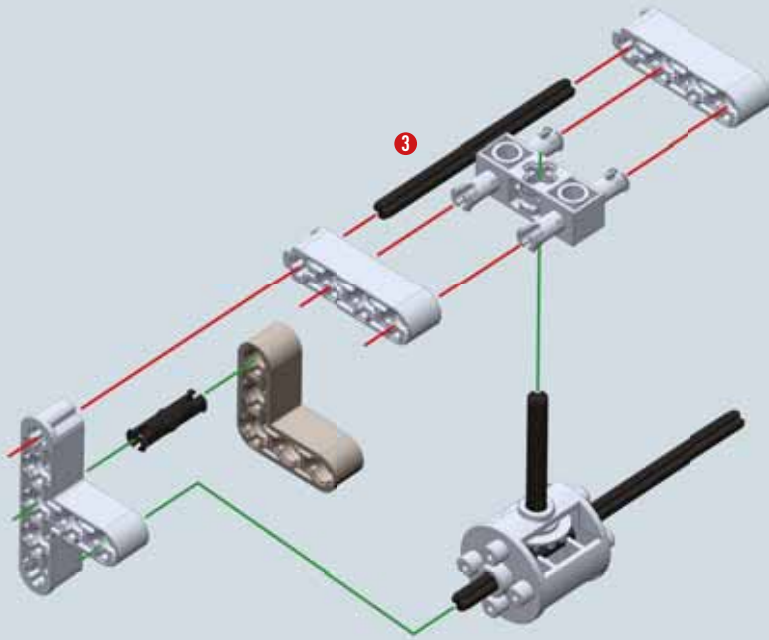

2

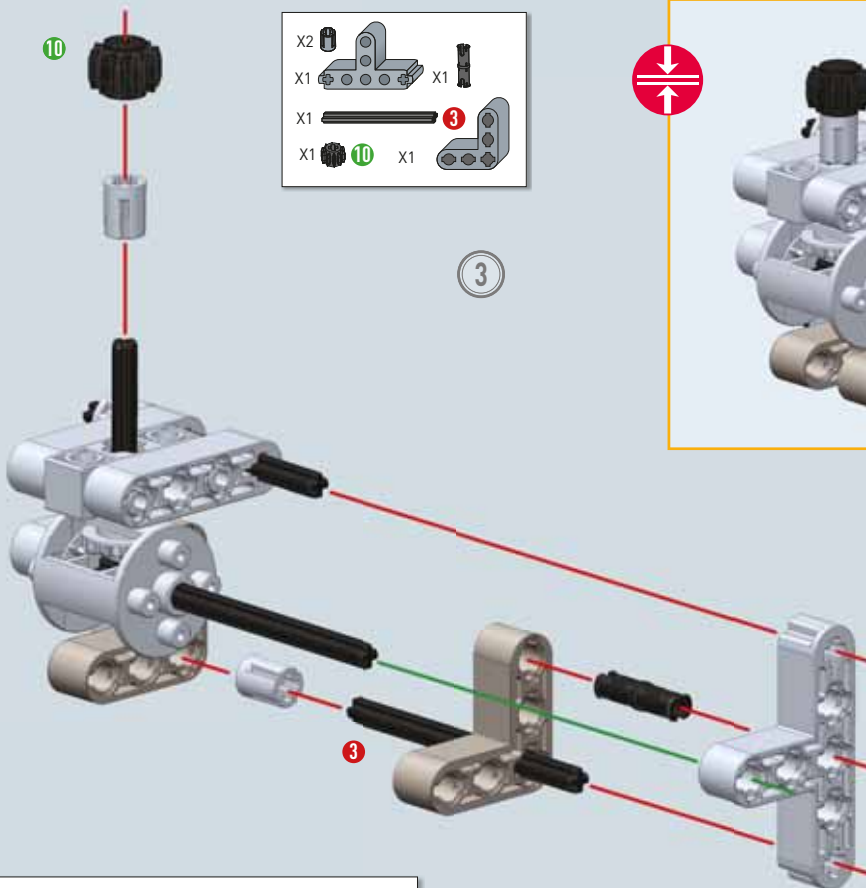
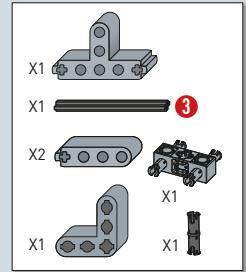

3

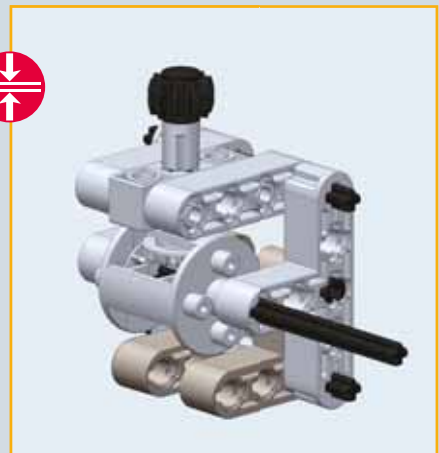
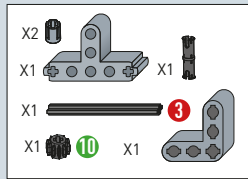

4

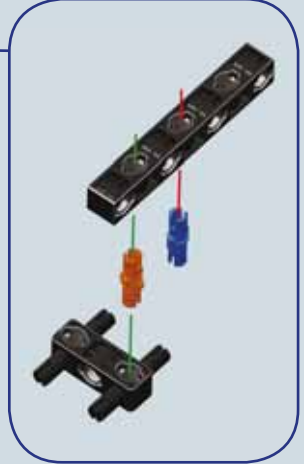
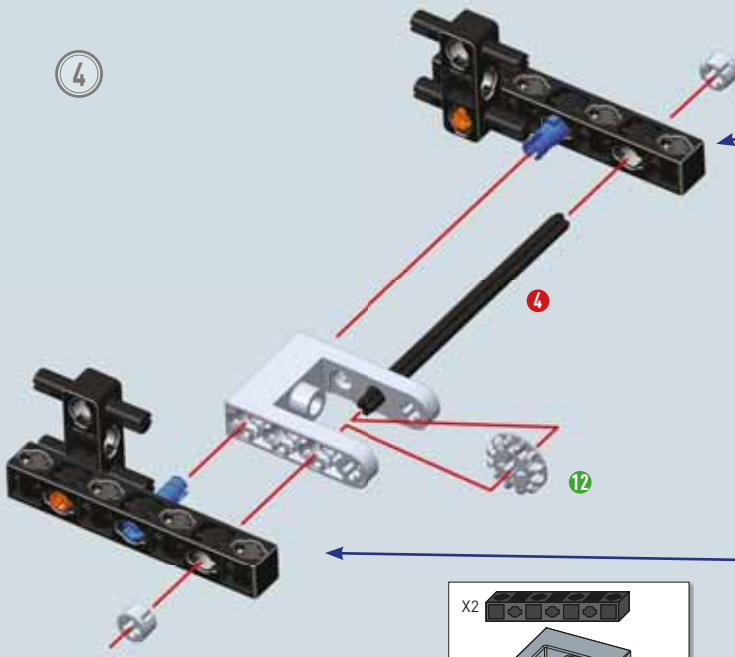

- X2
- X1
- X2
- X2
- X2
- X1

1:1

5

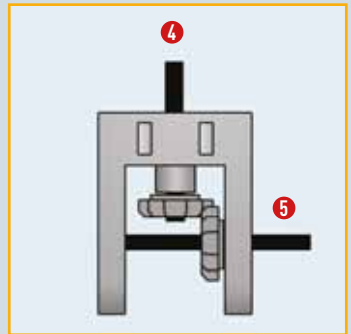
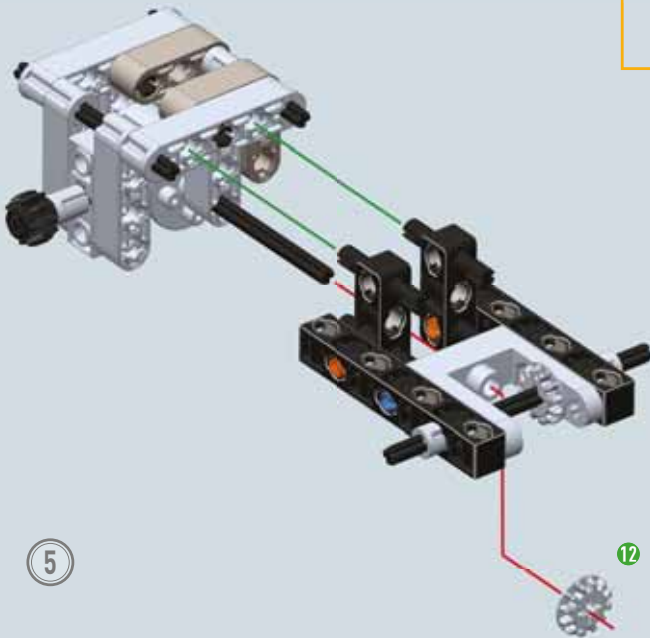

- X1

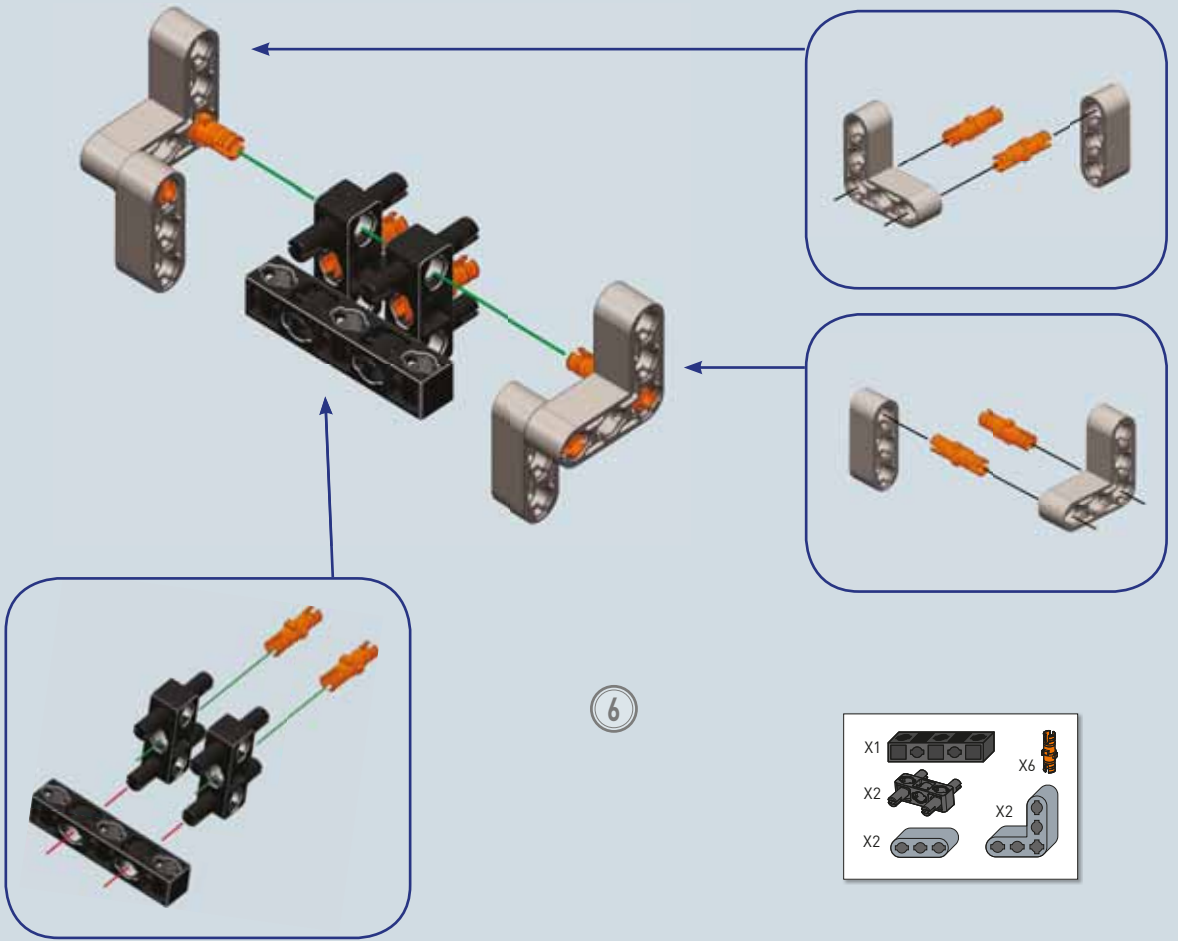

7

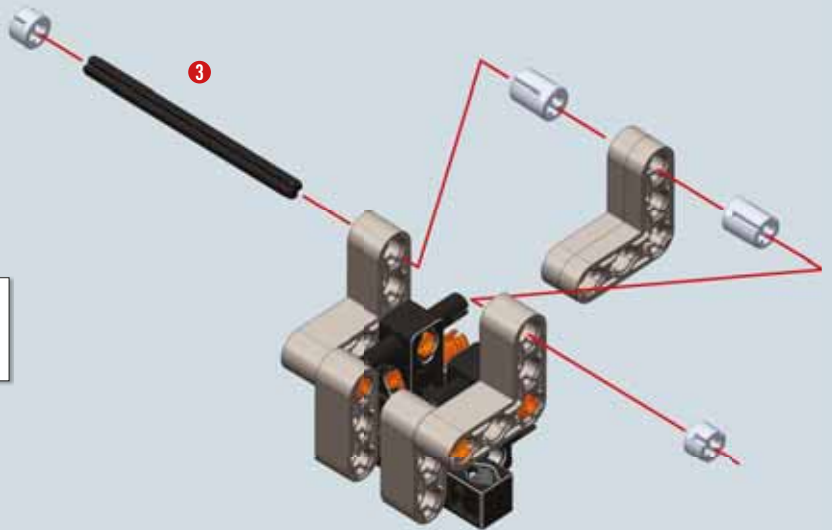
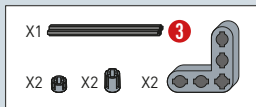

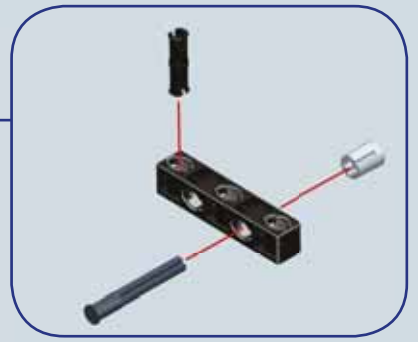

8

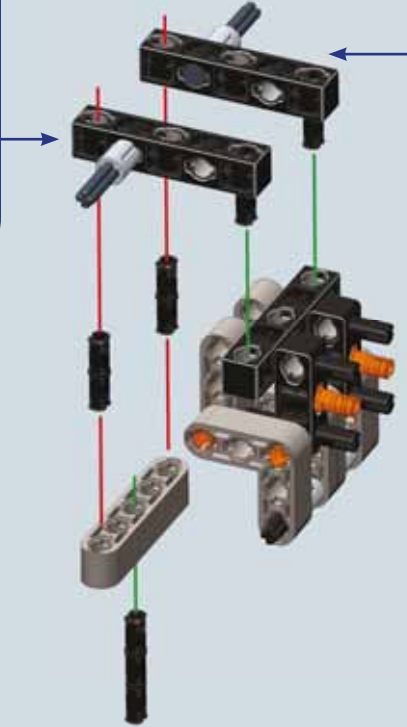

X1		X4	
X2		X2	
X2		X1	

9

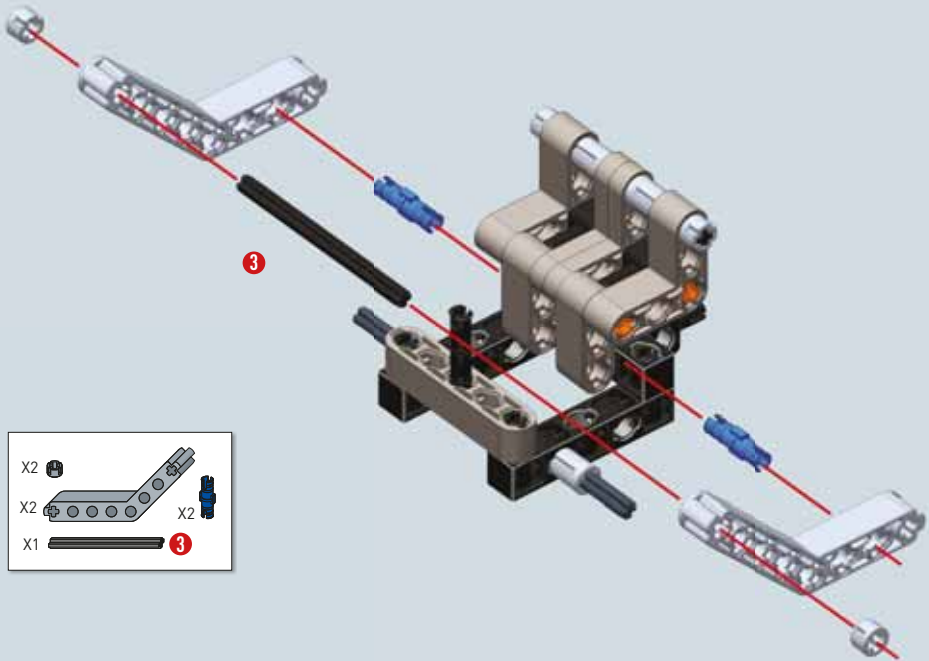

X2			
X2		X2	
X1			



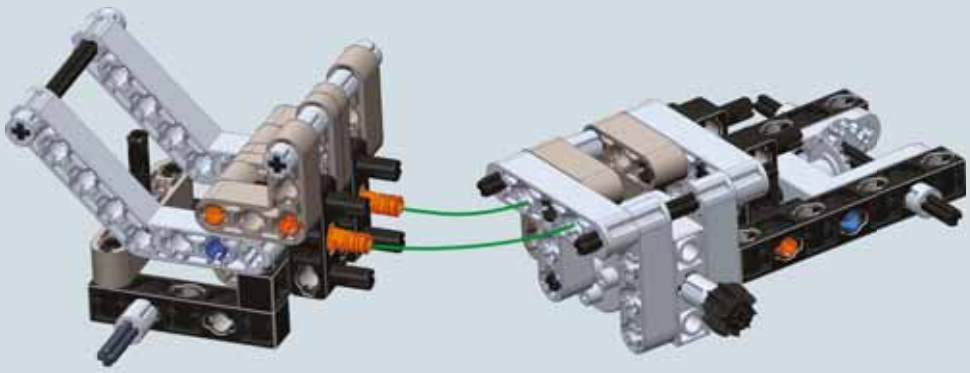

10

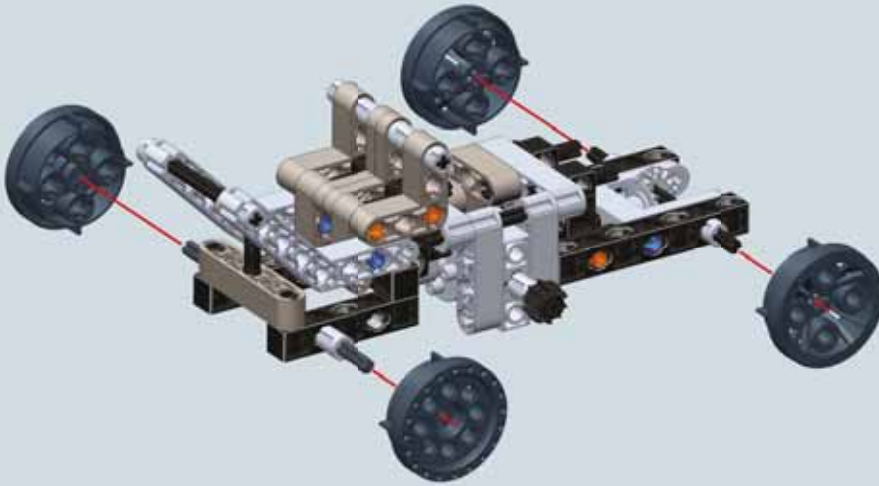

11

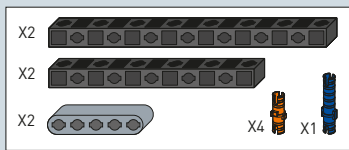
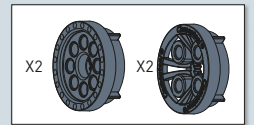

12

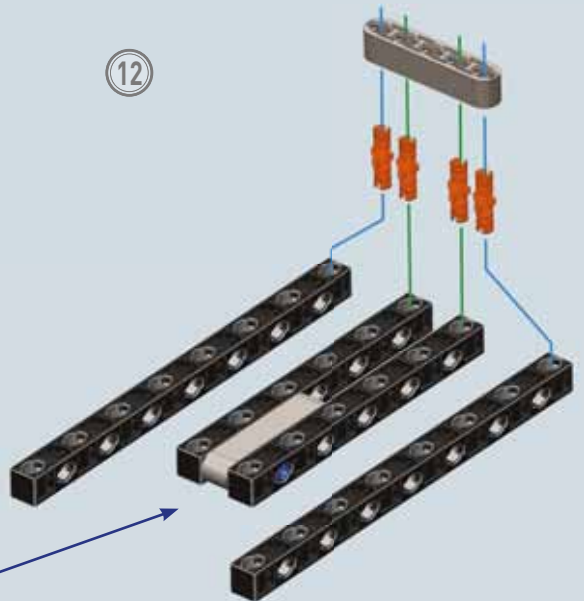
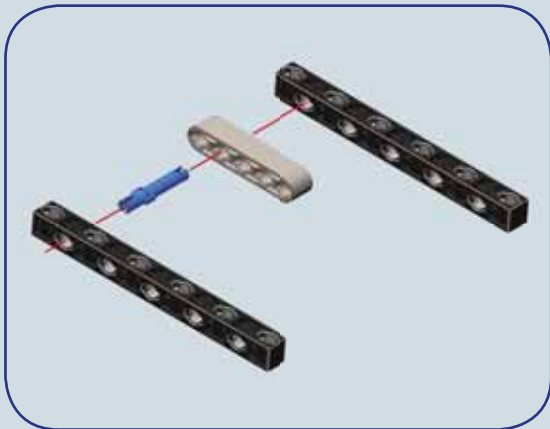

14

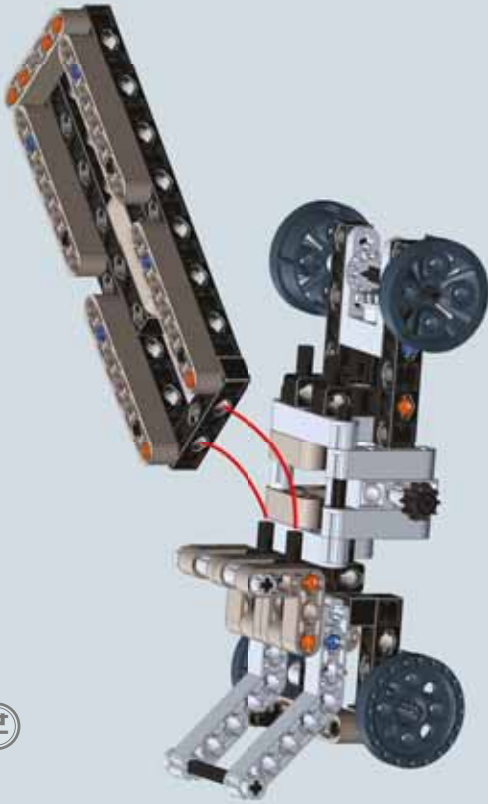

Montaji tamamlanmış model

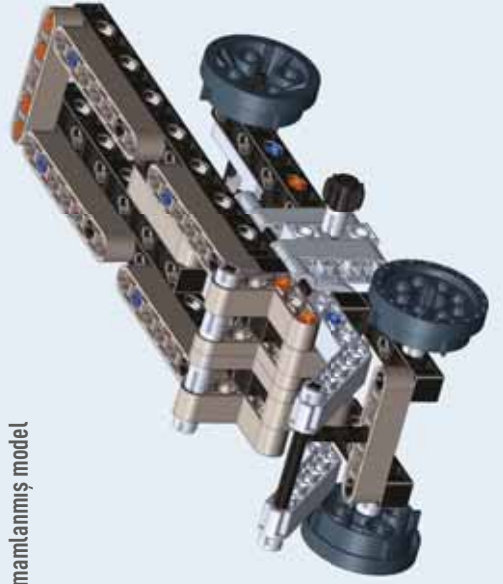

13

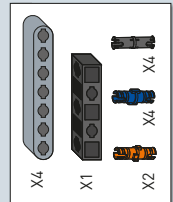
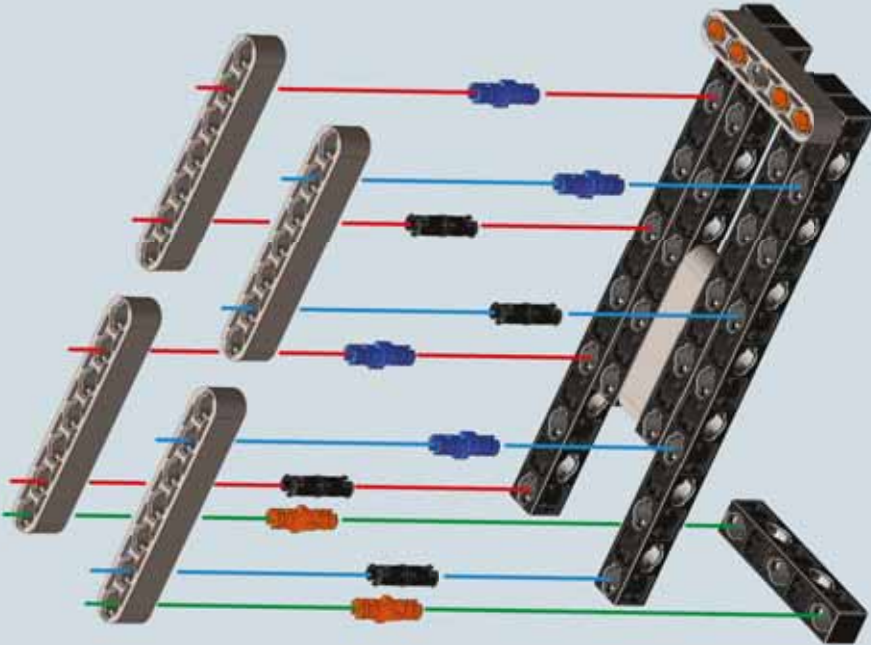

### 3 Maden kamyonu



#### Teknik unsurlar ve merak edilenler

Madencilik sektöründe kullanılan kamyonlar, tekerlekler üzerinde uzanan dev yapılarıdır. Büyük modellerin uzunluğu 7 metreyi (iki katlı bir binanın uzunluğu) bulabilir ve dizel motorları tıpkı bir kamyonet kadar büyüktür. Kasalar yaklaşık 10 metre uzunluğundadır ve büyük miktarda toprağa benzer malzeme taşıyabilir. Kasa tamamen yüklü olduğunda cihazın ağırlığı 600 tonu bulabilir. Yük kamyonları genellikle 6 tekerleklidir; bu tekerlekler de oldukça büyüktür (çapları kabaca 4 metredir).

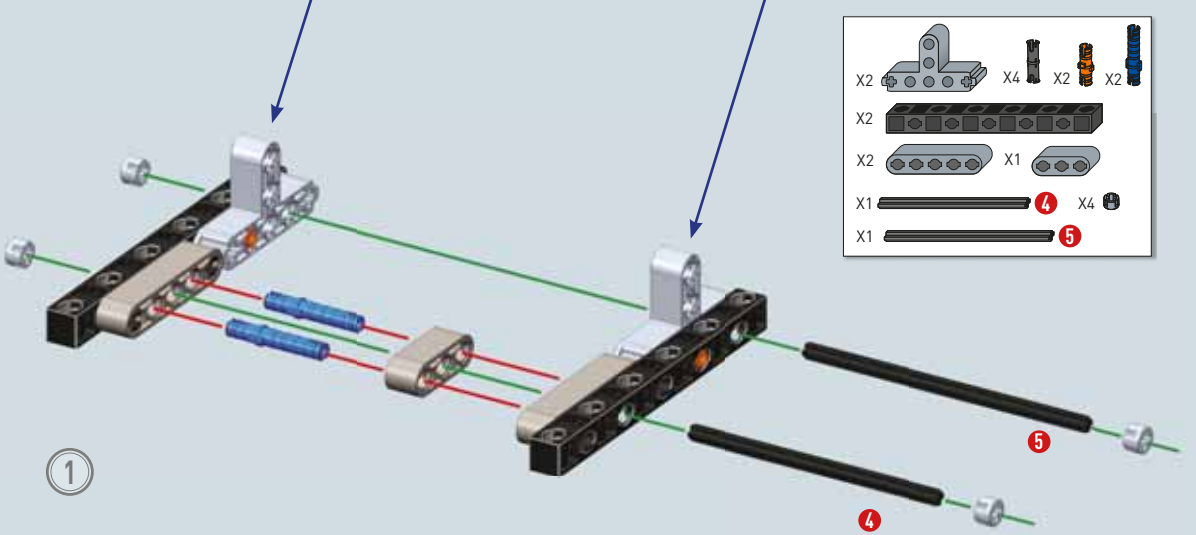
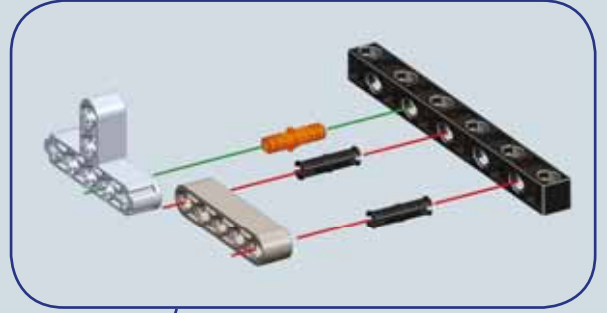
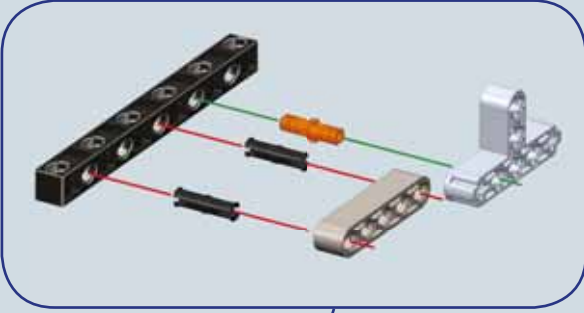

X2		X4		X2		X2	
X2							
X2		X1					
X1		X4					
X1							

1:1

1:1

2

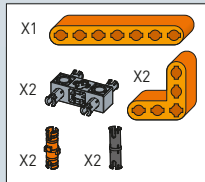
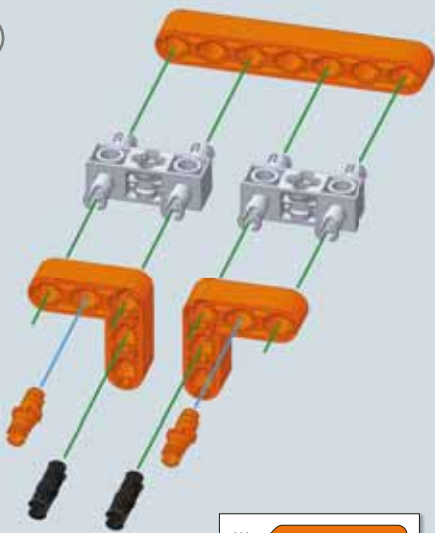

3

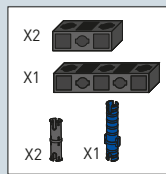

4

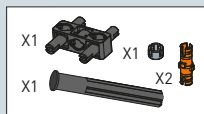

5





6

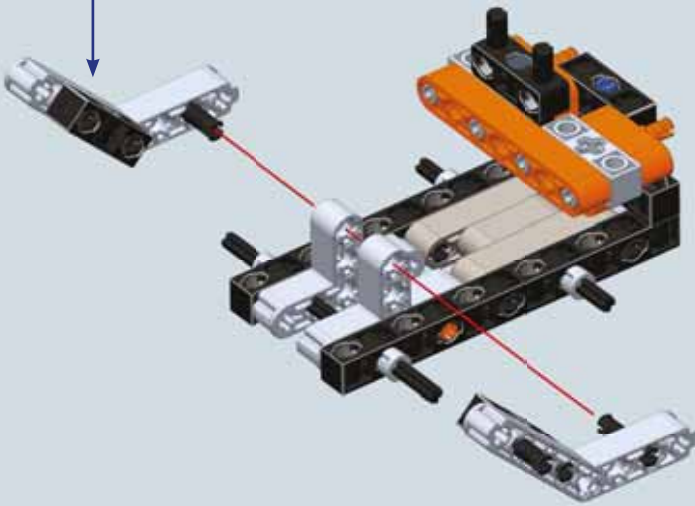
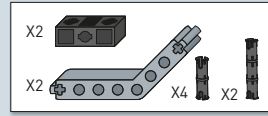

7

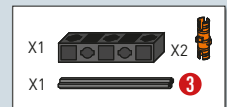
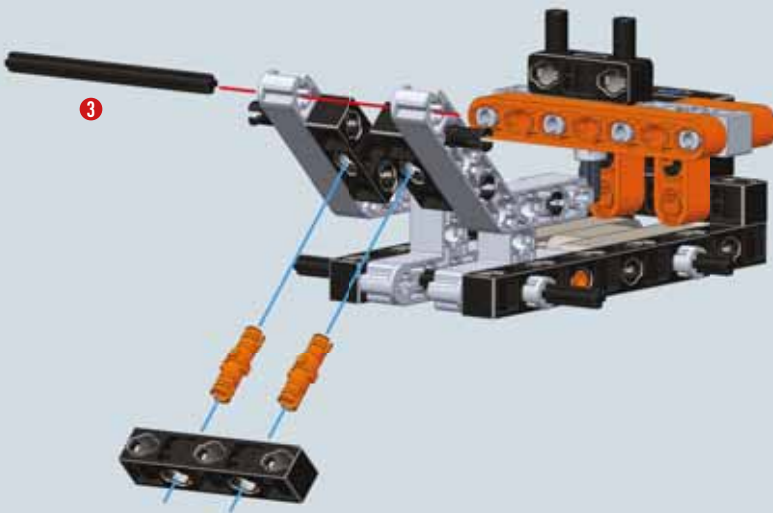

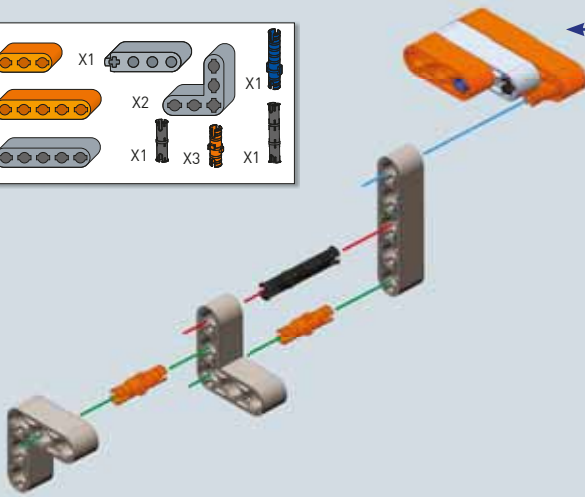
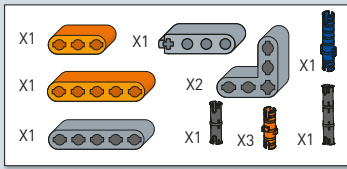

8

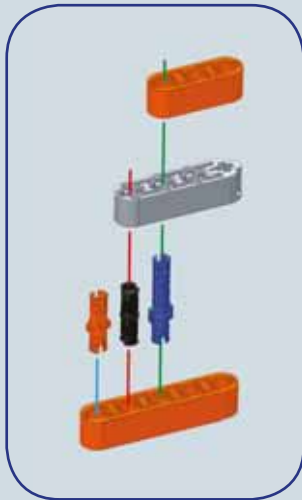
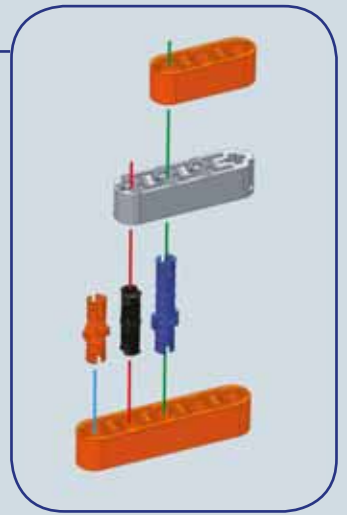

9

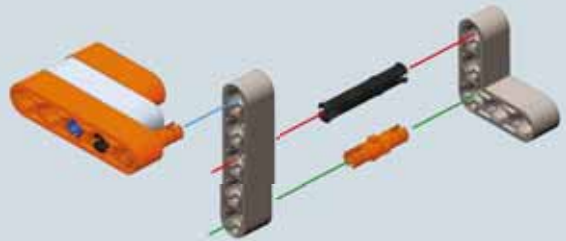
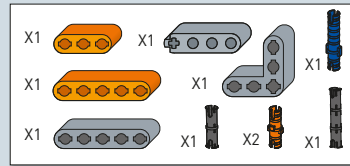

10

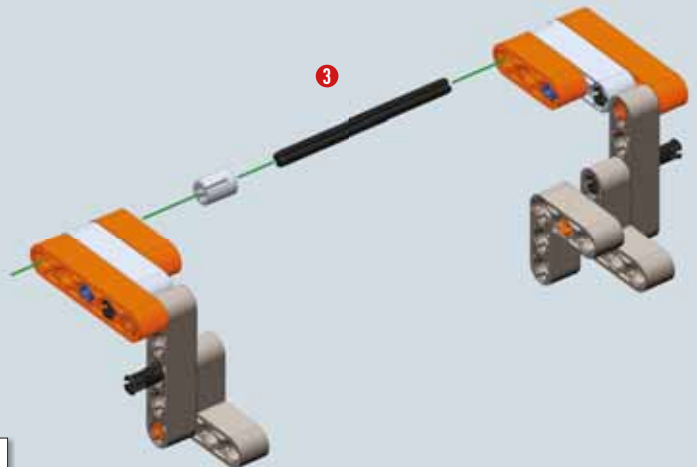
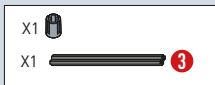

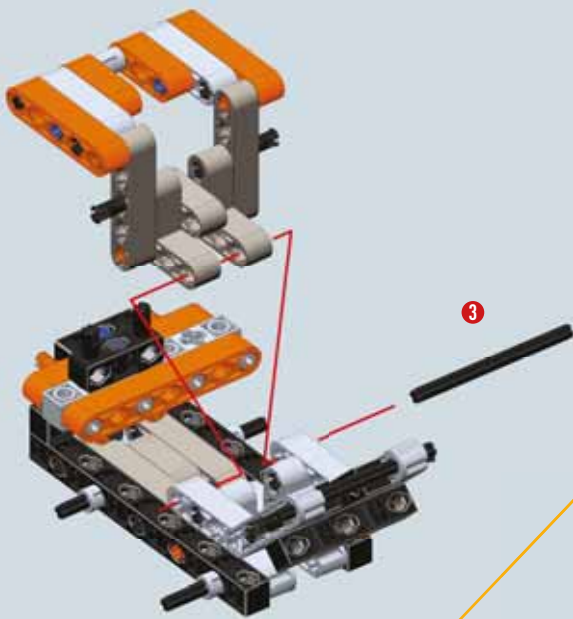





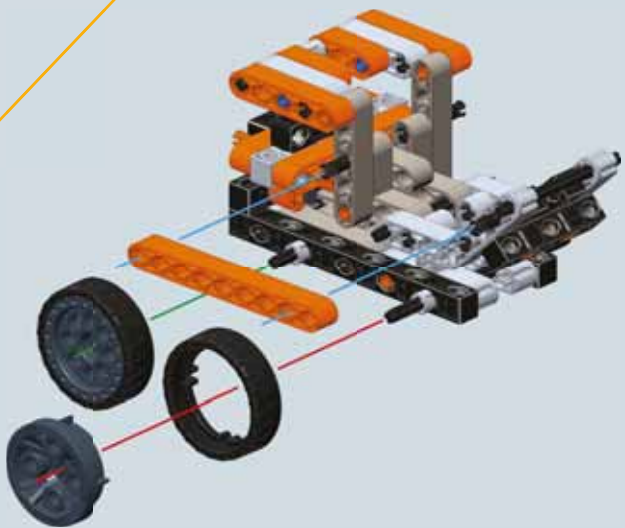



X1  3

1:1  3

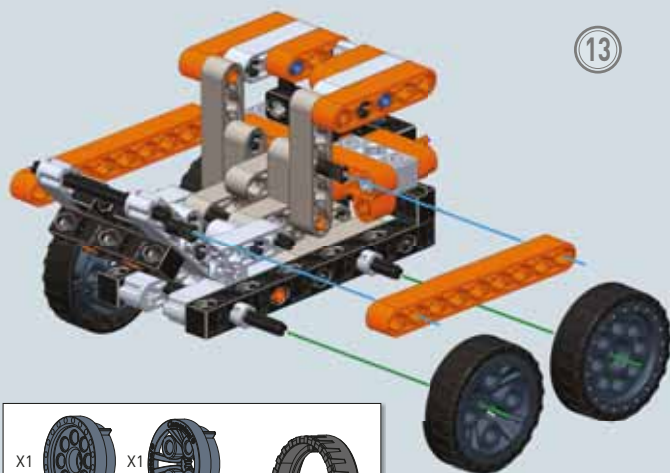

X1  X1  X2   
X1 



X1  X1  X2   
X1 





### Teknik unsurlar ve merak edilenler

Bu kamyon, ürün taşımak için tasarlanan bir taşıttır. Güçlü dizel motorlara sahip olan bu kamyonlar 4 ila 6 tekerlekli olabilir. Bu etkinlikte kara yolu traktörü parçalarını bir araya getireceğiz. Bu traktör, birleştirildiğinde özel ve karmaşık bir taşıt olan tır kamyonu hâline gelen treylerleri taşımak için özel olarak tasarlanmış bir taşıt haline gelir. Kamyon ve kara yolu traktörü arasındaki fark, kara yolu traktörünün tek başına ürün taşımada kullanılmamasıdır.

Klasik Avrupa kamyonu olan düz başlı kamyonun tasarımı, güvenlik ve trafik yönetimiyle ilgili sebeplerden dolayı taşıt boyutlarında yapılan sıkı düzenlemeler sonucunda ortaya çıkmıştır.

Eskiden çiftlik traktörleri kara yolu traktörü olarak kullanılırdı, ancak kasa ve tekerlekleri özgün modellere göre biraz daha farklıydı.

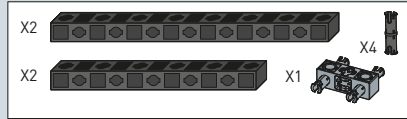
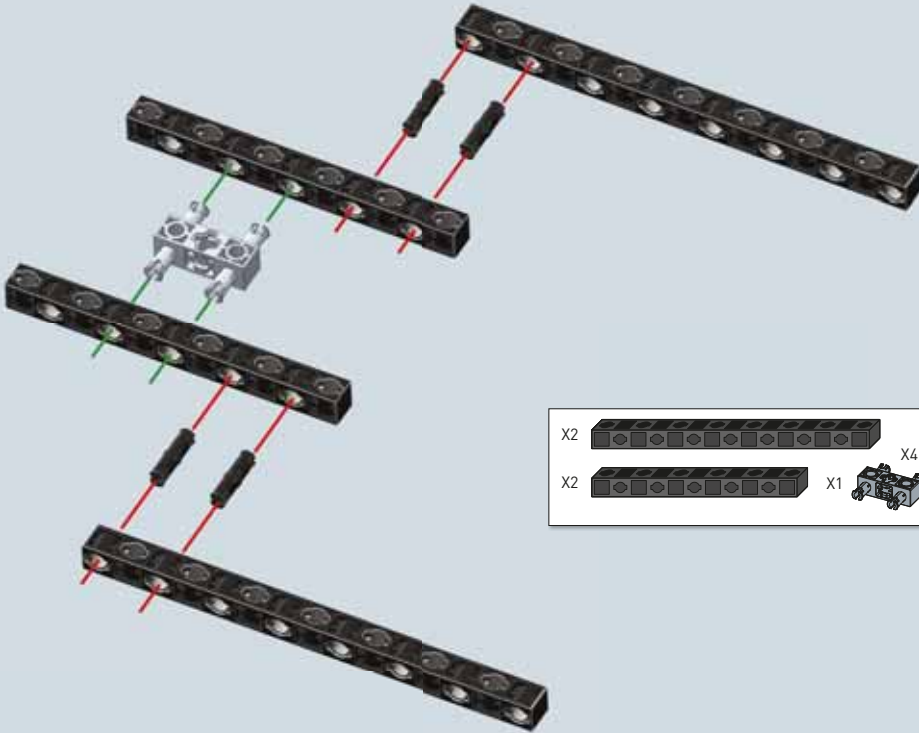

1

2

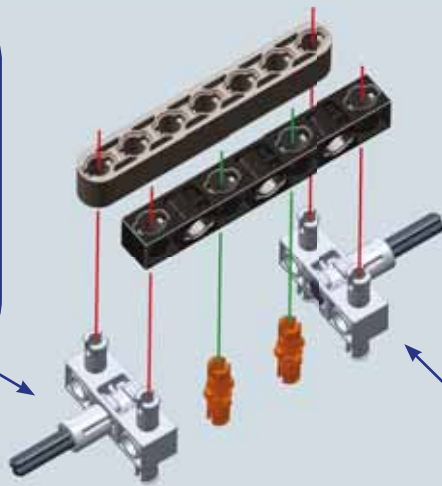

- X1
- X1
- X2
- X2
- X2
- X2
- X2

3

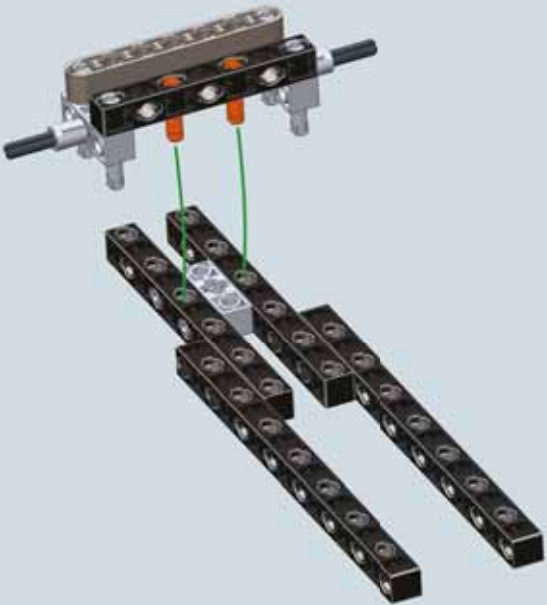

- X1
- X1
- X1
- X1

4

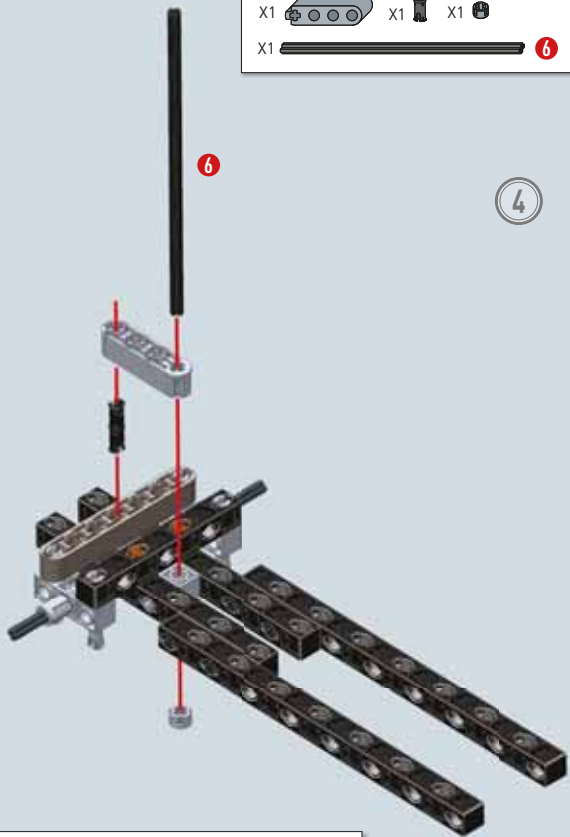

- 1:1

5

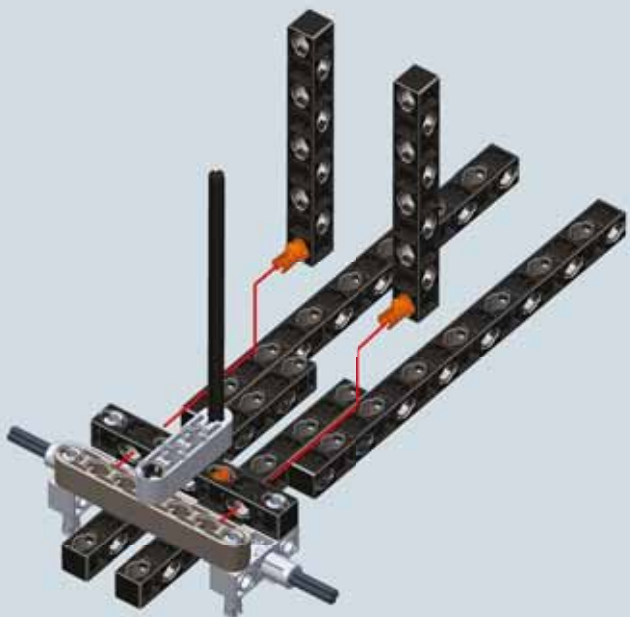

6

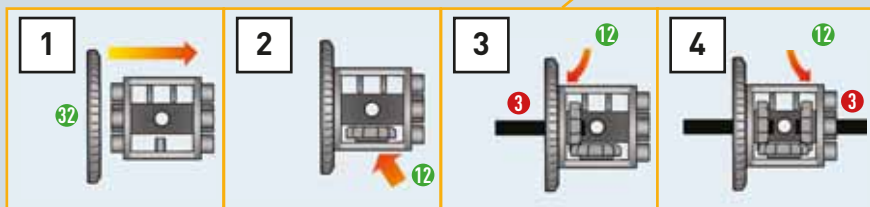
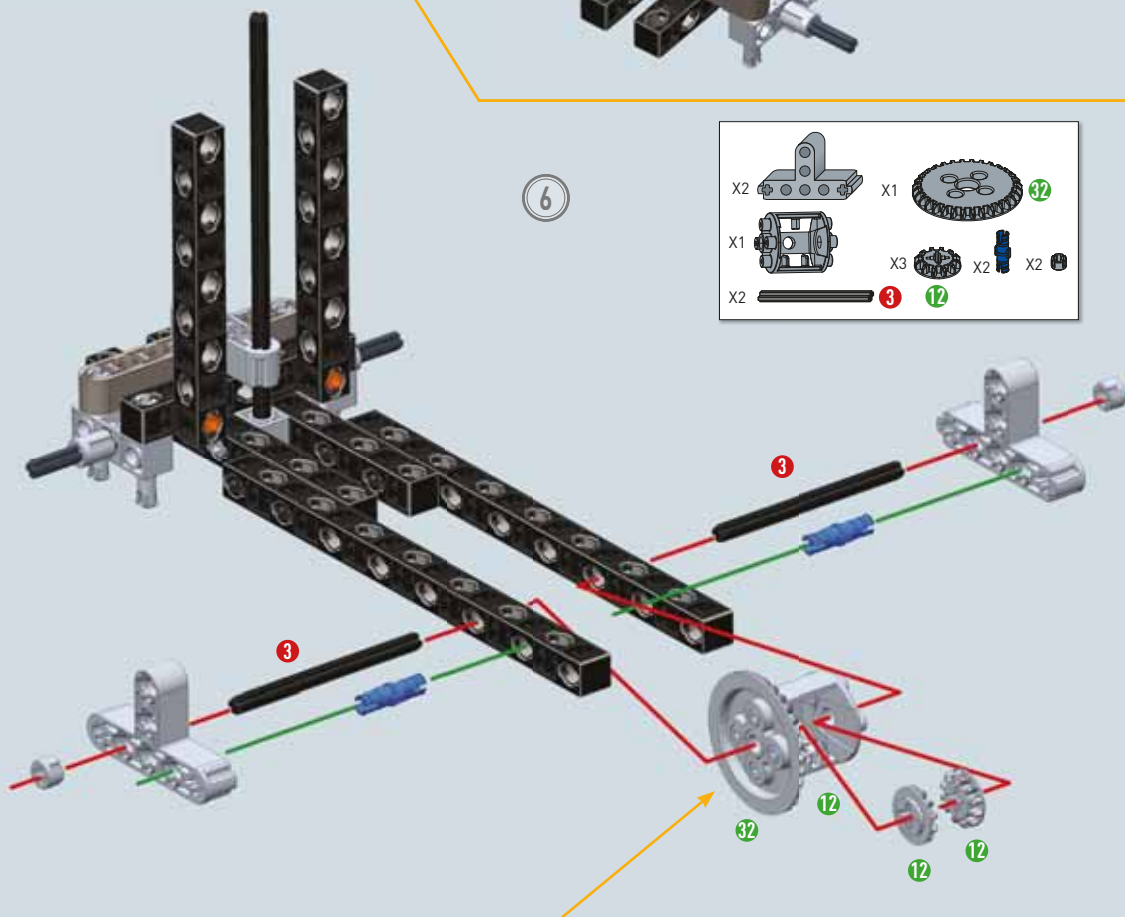
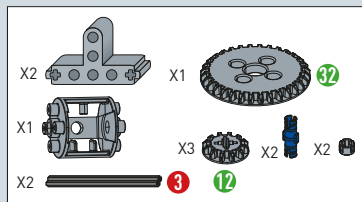

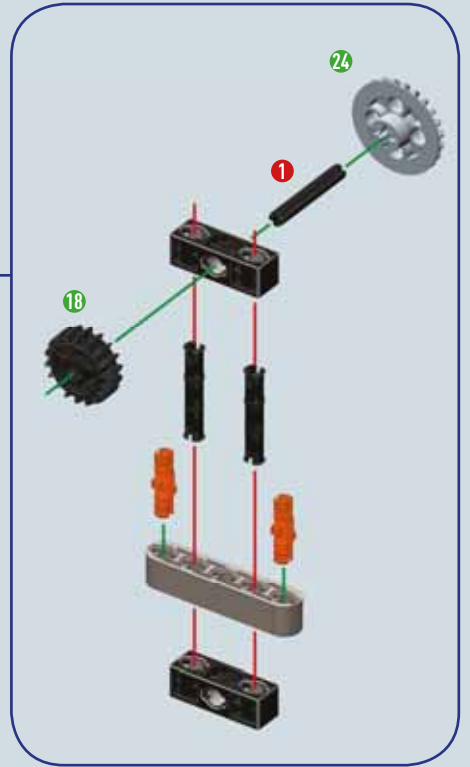
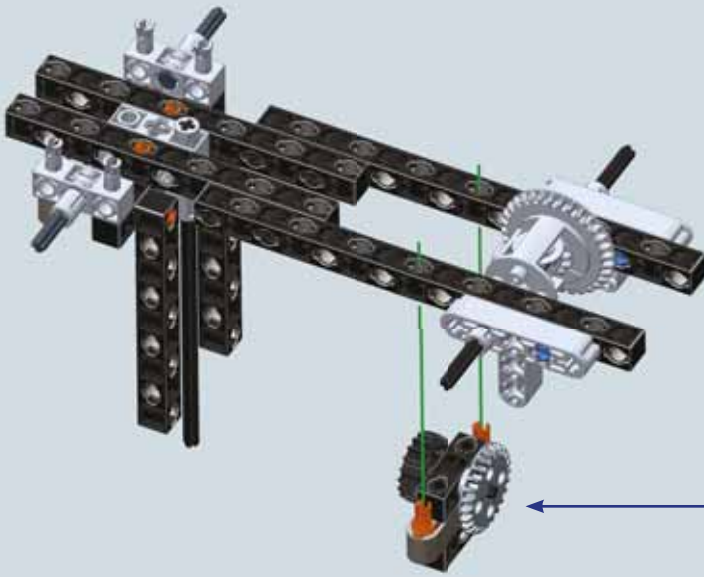

- |    |  |    |  |
|----|--|----|--|
| X1 |  | X1 |  |
| X2 |  | X2 |  |
| X1 |  | X1 |  |
| X2 |  | X2 |  |

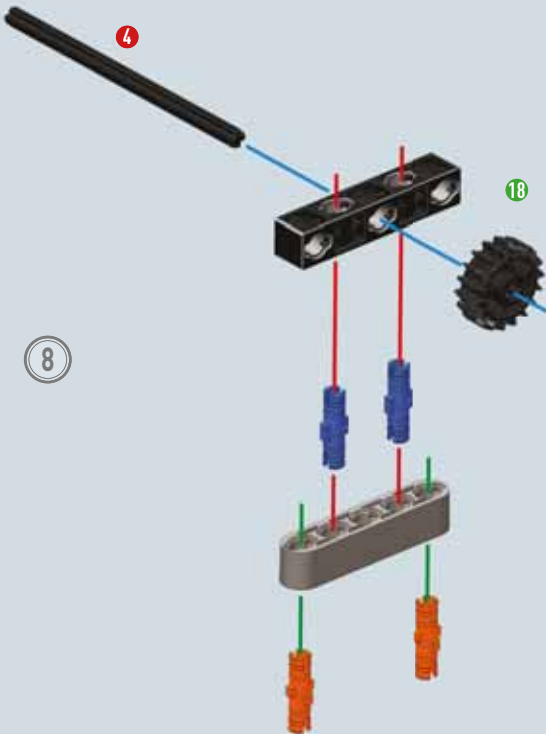

- |    |  |    |  |    |  |
|----|--|----|--|----|--|
| X1 |  | X1 |  | X2 |  |
| X1 |  | X2 |  | X2 |  |
| X1 |  | X2 |  |    |  |



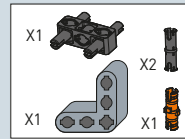
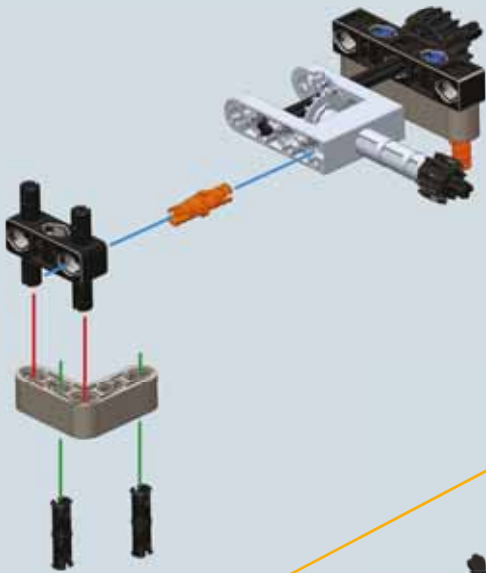
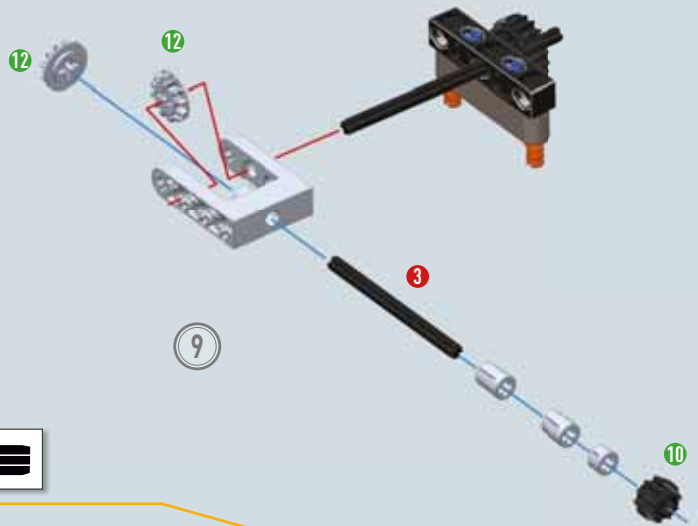
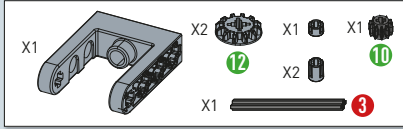
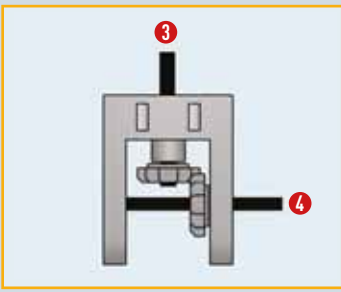

10

11

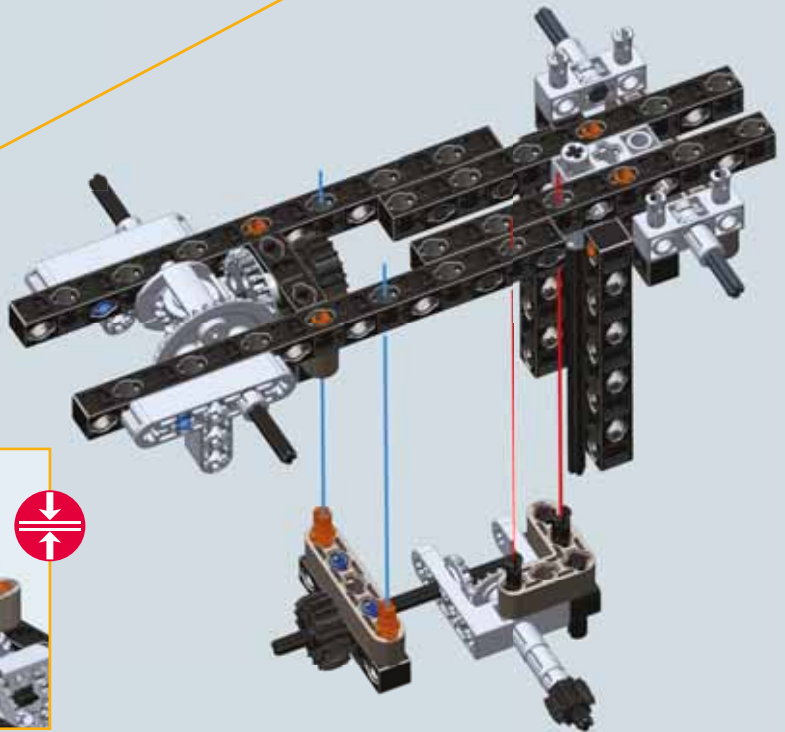



12

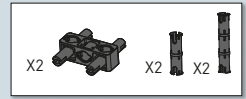
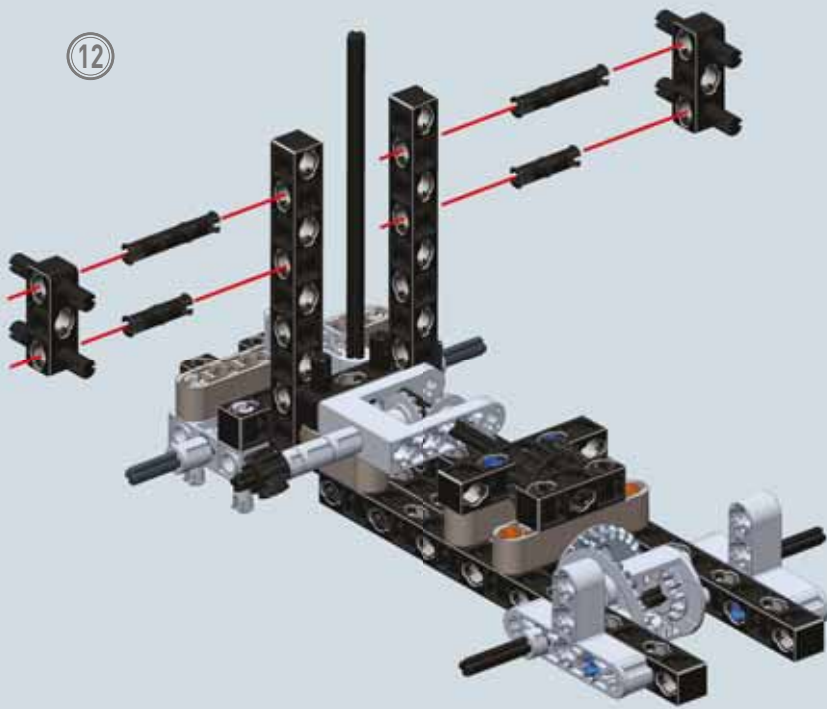

13

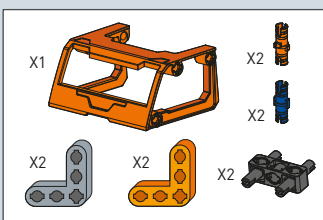
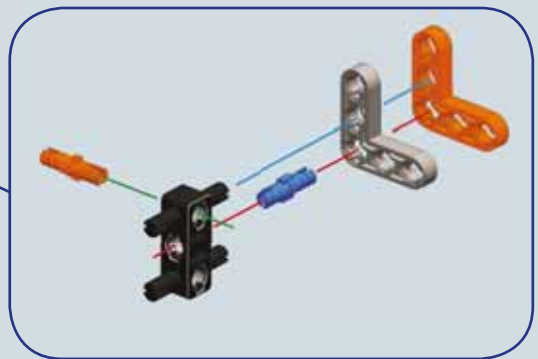
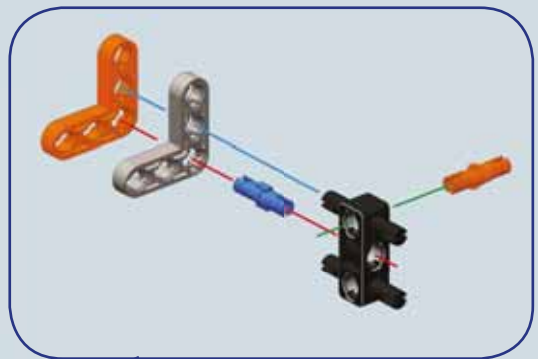
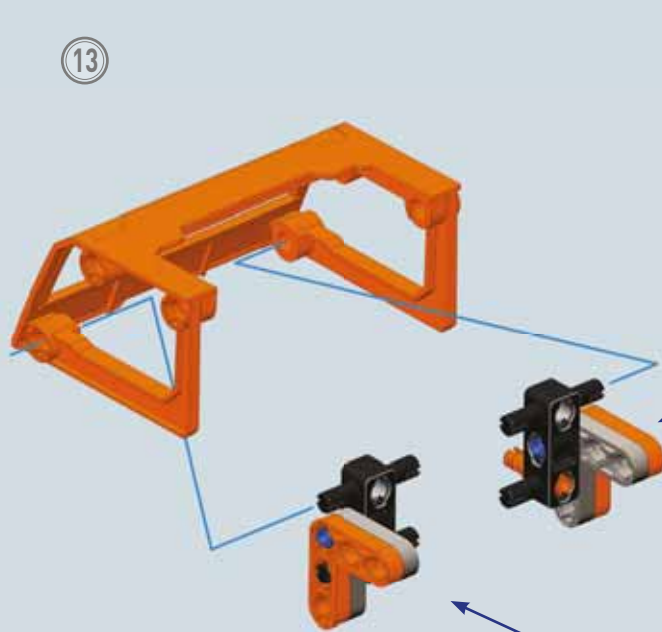

14

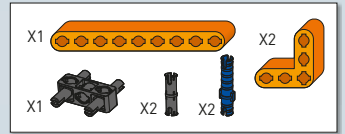
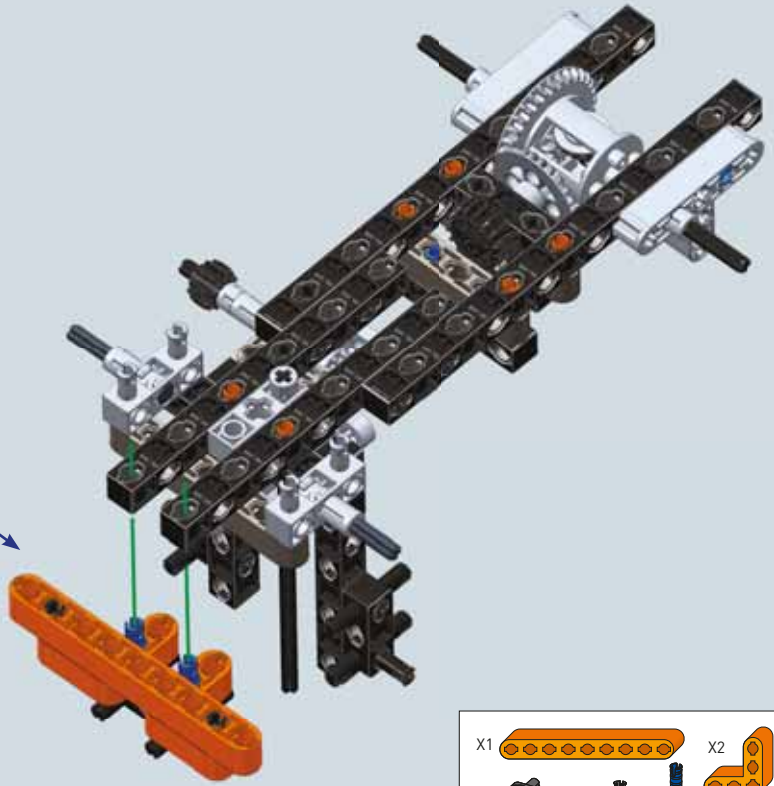
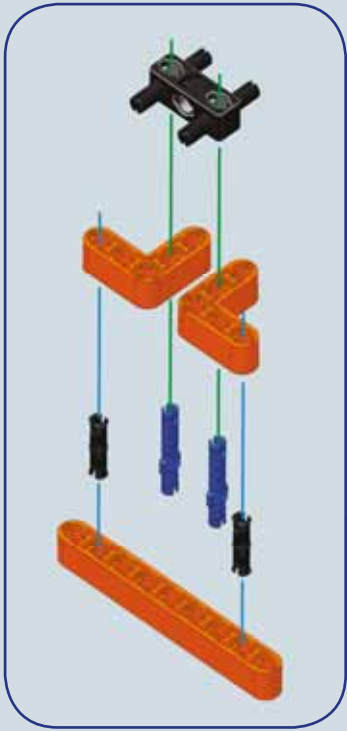

15

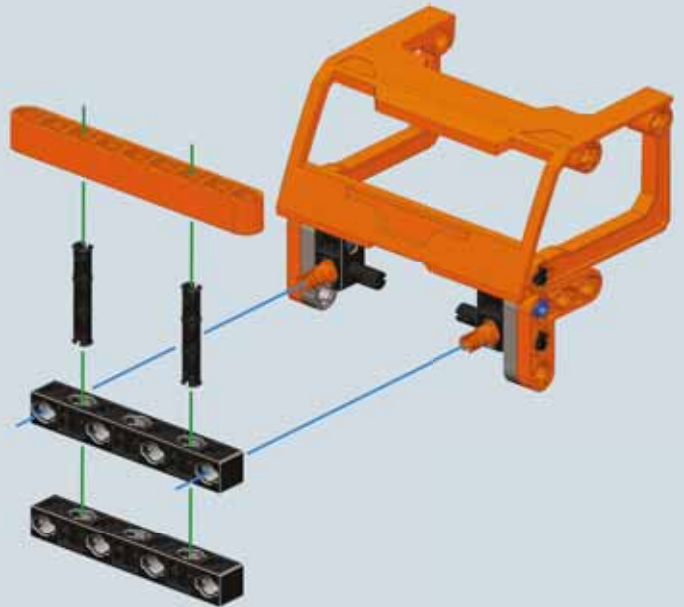
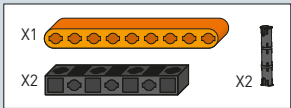

16

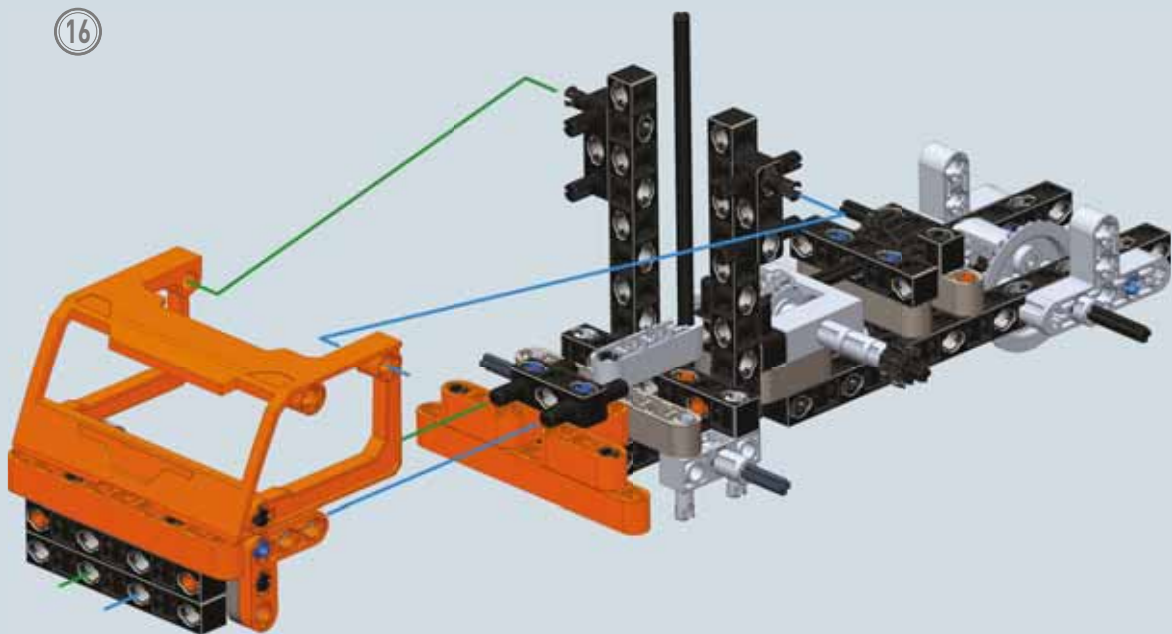

17

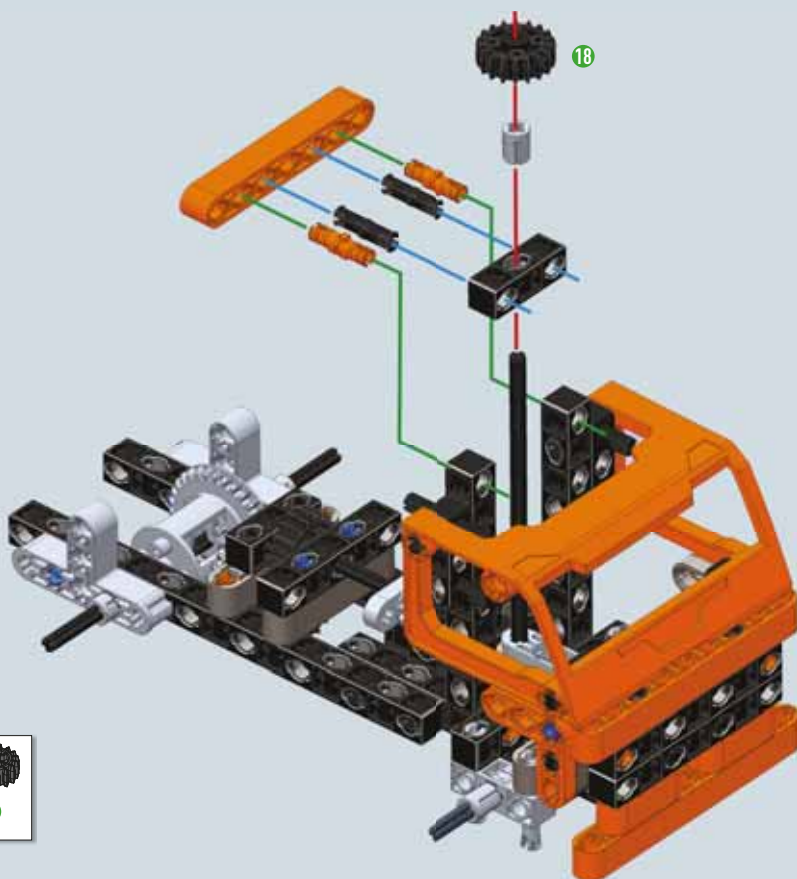

- |    |    |    |    |  |  |
|----|----|----|----|--|--|
| X1 |    | X1 |    |  |  |
| X1 |    | X1 |    |  |  |
|    | X2 |    | X2 |  |  |

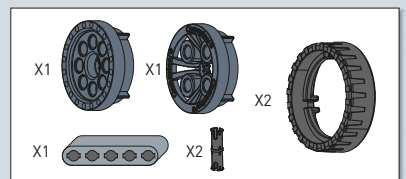
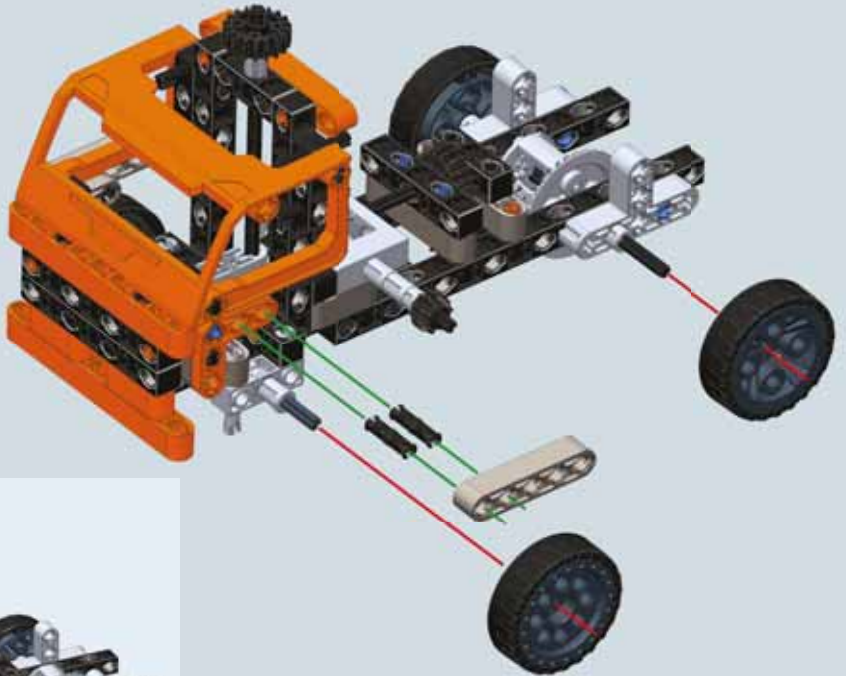
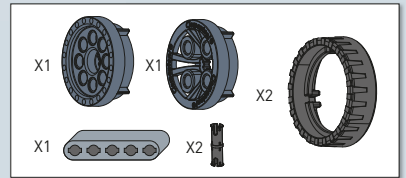
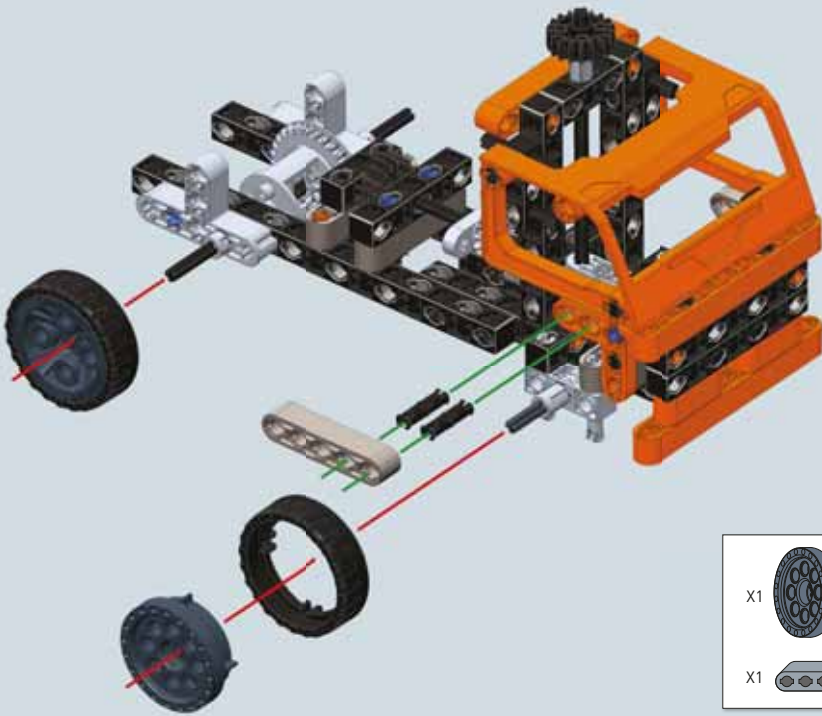

Montajı tamamlanmış model

## 5 Kısaç kepçeli kamyon



### Teknik unsurlar ve merak edilener

Hidrolik kısaçklı kepçe, bir veya daha fazla hidrolik silindir tarafından çalıştırılan kısaçklardan oluşan bir kavrama ekipmanıdır. Kısaçklı kepçeyi kamyonu bağlayan uzatılabilir kol, hareket etmek için aynı hidrolik tahrik mekanizmalarını kullanır. Bu tür taşıtlar, ormancılık uygulamalarında ticari kullanıma yönelik kereste yükleme işlemleri için kullanılmaktadır. Buna ek olarak, bu taşıtlar kütük ve dallarla kaplı alanları temizlemek için de kullanılabilir.

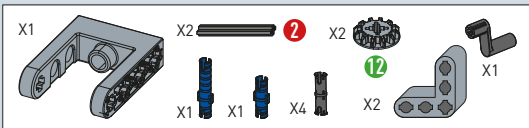
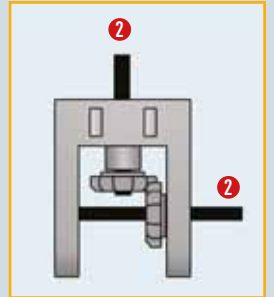
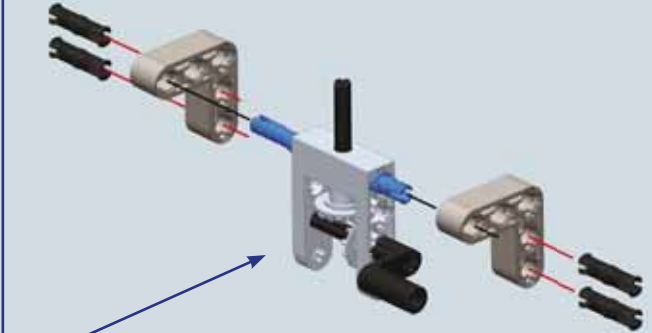
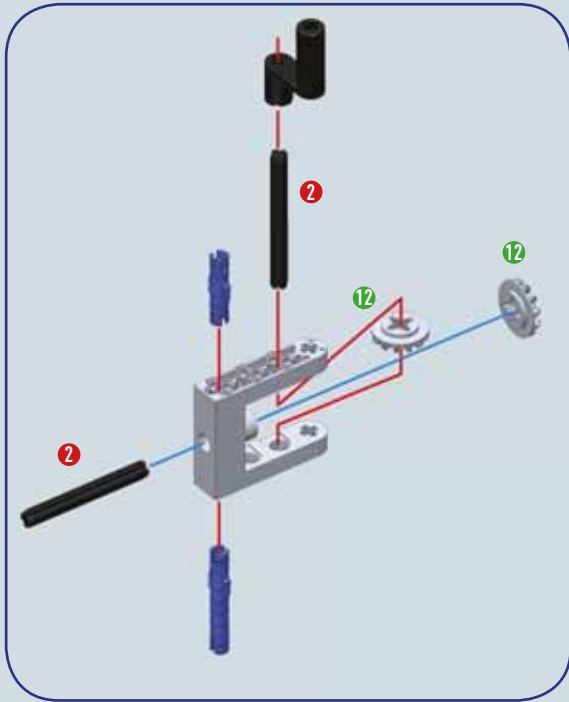

①

1:1



2



4. Etkinlikte kurulan model

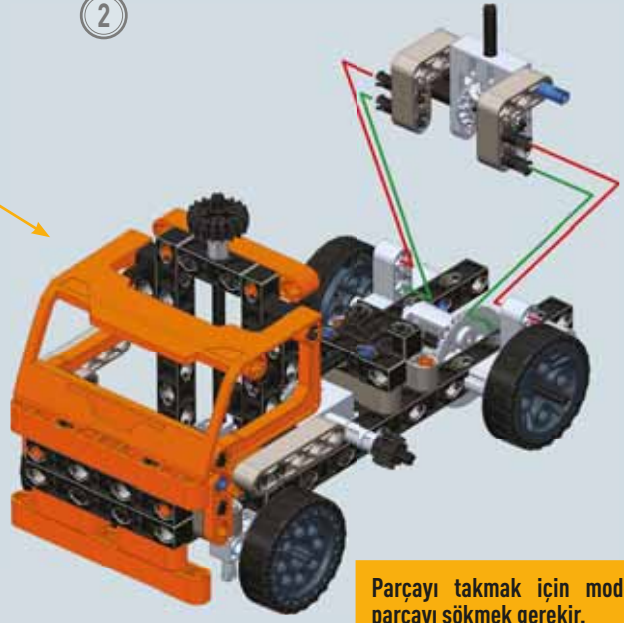

Parçayı takmak için modeldeki parçayı sökmek gerekir.

3

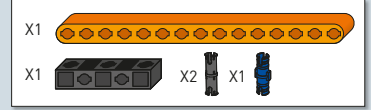
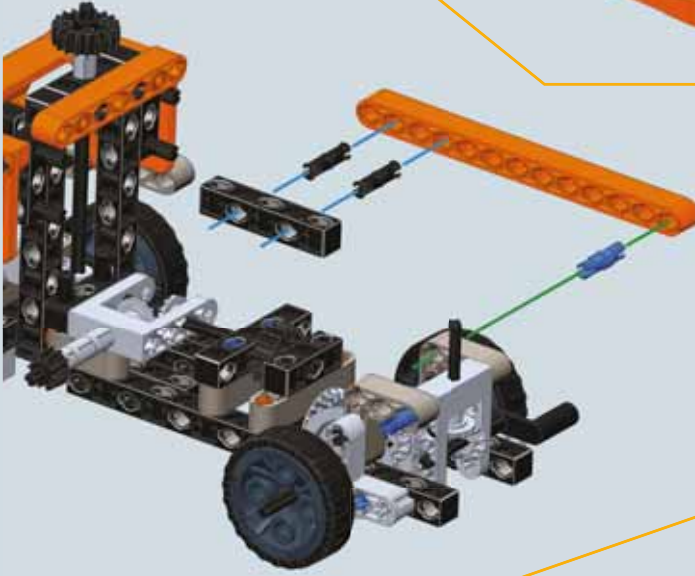

4

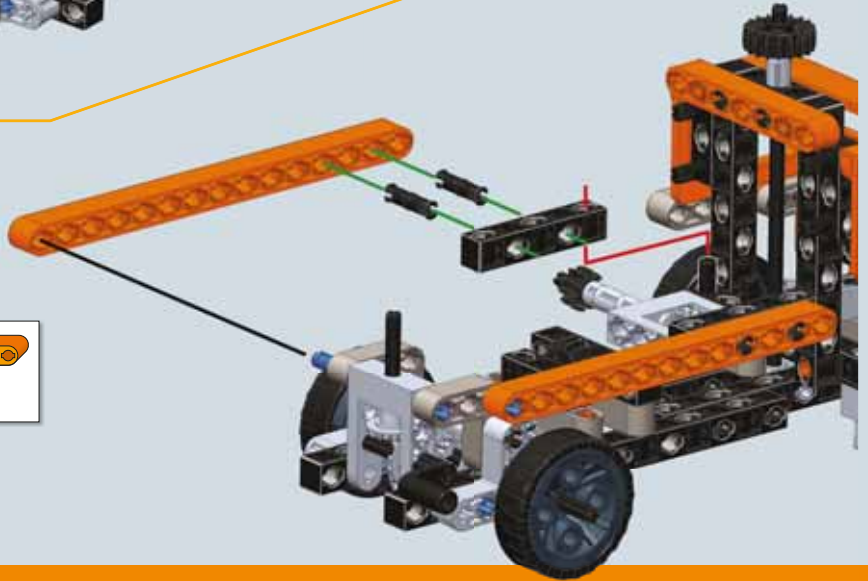
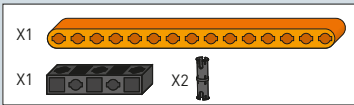

5



6

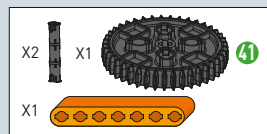
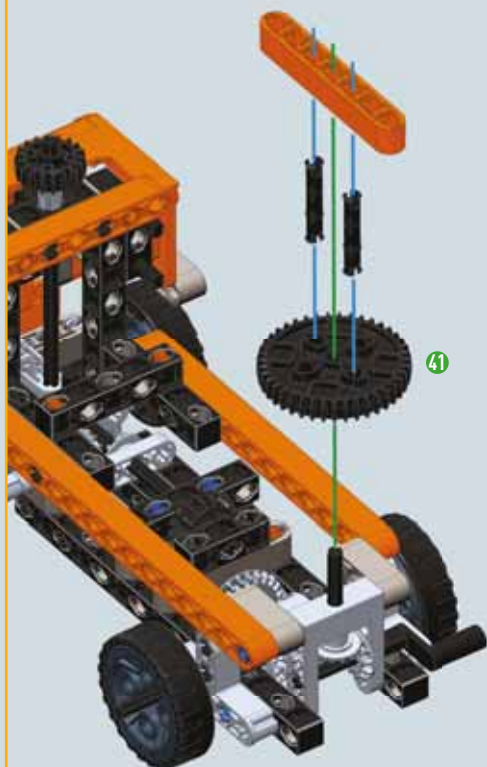

7

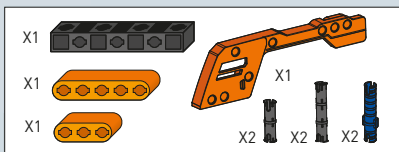
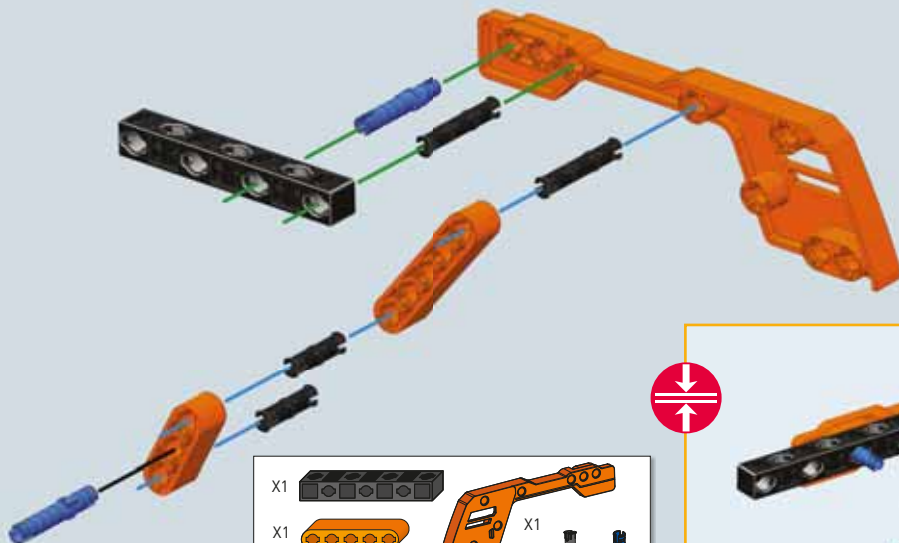

8

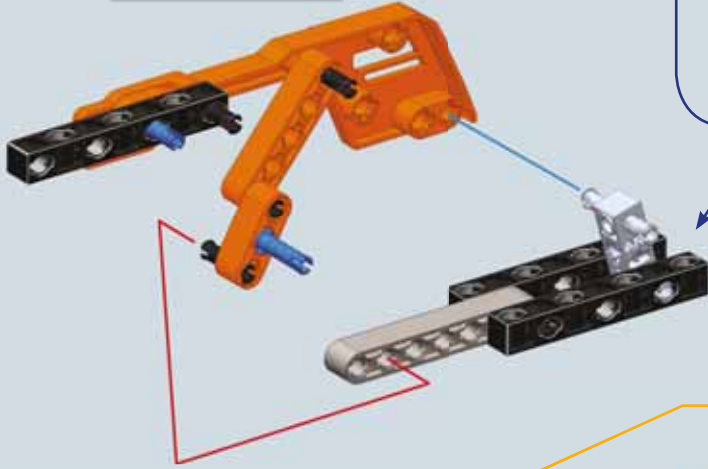
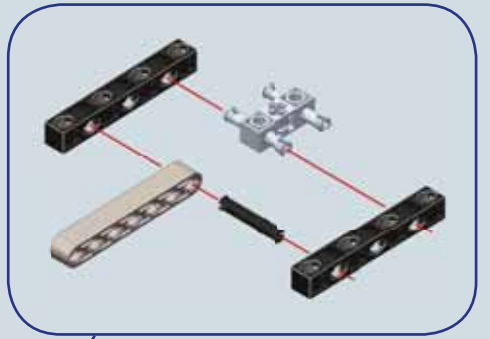
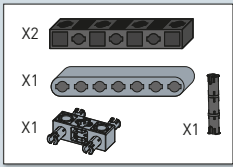

9

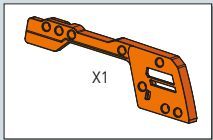

10





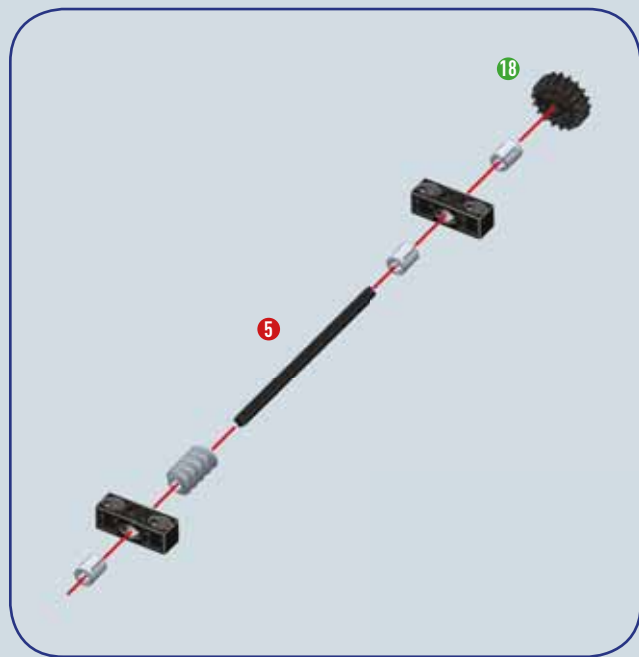

11



- |    |  |    |  |          |           |
|----|--|----|--|----------|-----------|
| X2 |  | X3 |  | X1       |           |
| X2 |  |    |  |          | <b>18</b> |
| X1 |  |    |  | <b>5</b> |           |
| X1 |  | X3 |  | X1       |           |

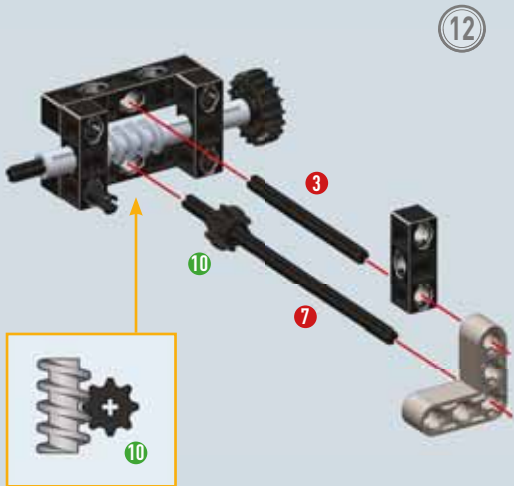

12

- |    |  |    |  |          |           |
|----|--|----|--|----------|-----------|
| X1 |  | X1 |  | X1       |           |
| X1 |  |    |  |          | <b>10</b> |
| X1 |  |    |  | <b>7</b> |           |

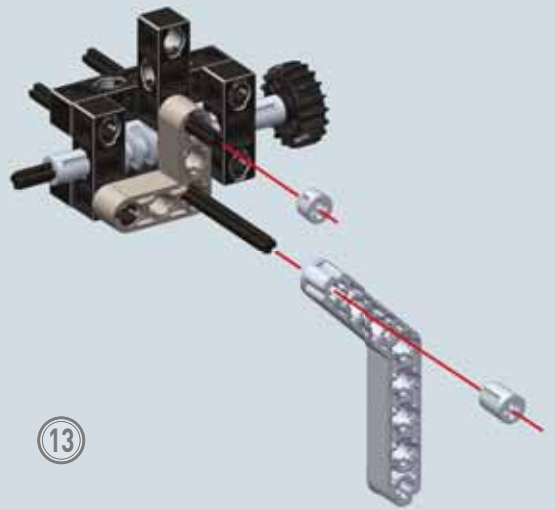

13

- |    |  |    |  |
|----|--|----|--|
| X1 |  | X1 |  |
| X1 |  |    |  |

14

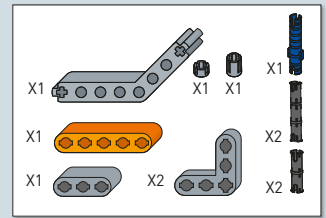
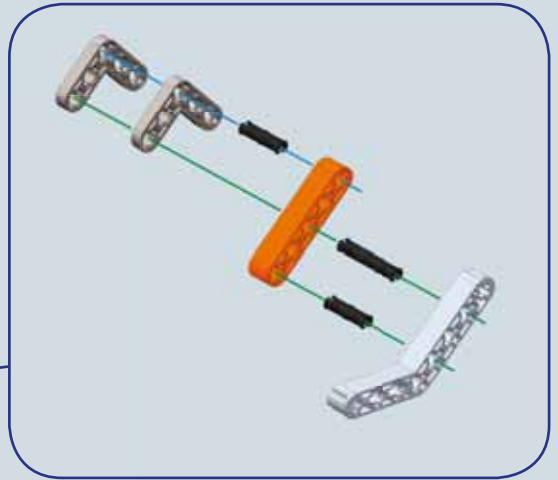
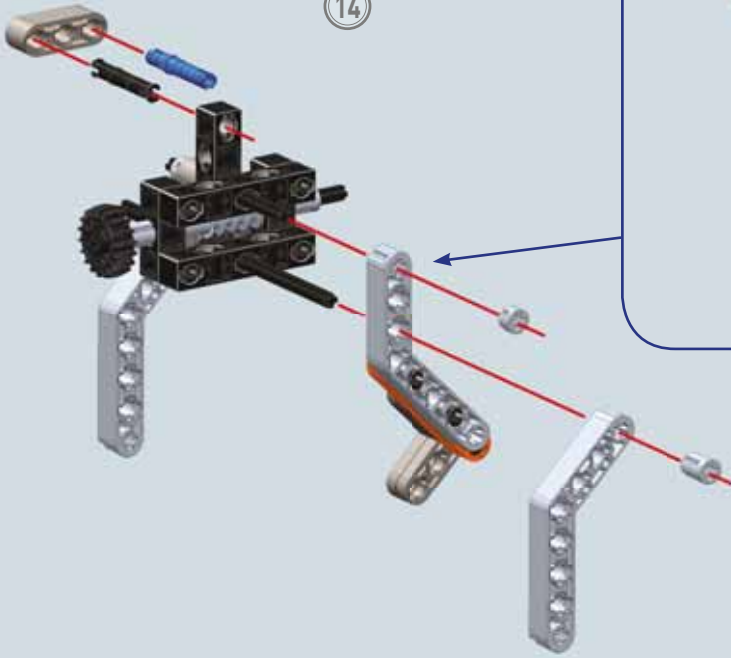

15

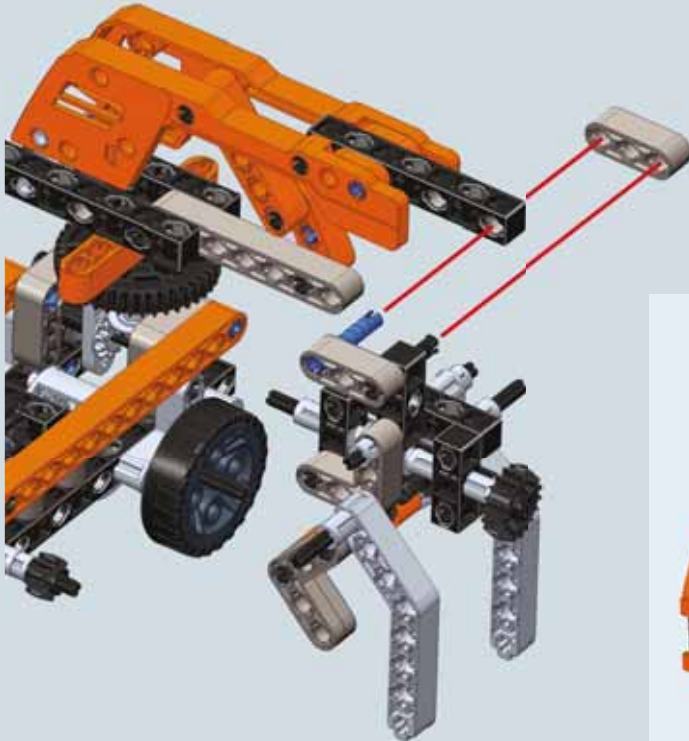

Montajı tamamlanmış model

## 6 Damperli kamyon



### Teknik unsurlar ve merak edilenler

Damperli kamyon, bağımsız olarak ürün taşımak için de kullanılabilir. Bu taşıt genellikle kum, çakıl veya çöp gibi döküm yükleri taşımak için kullanılır. Bu durumda damper mekanizması hidrolik pistonlar sayesinde çalışır.

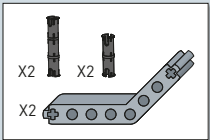
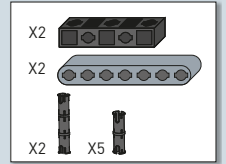
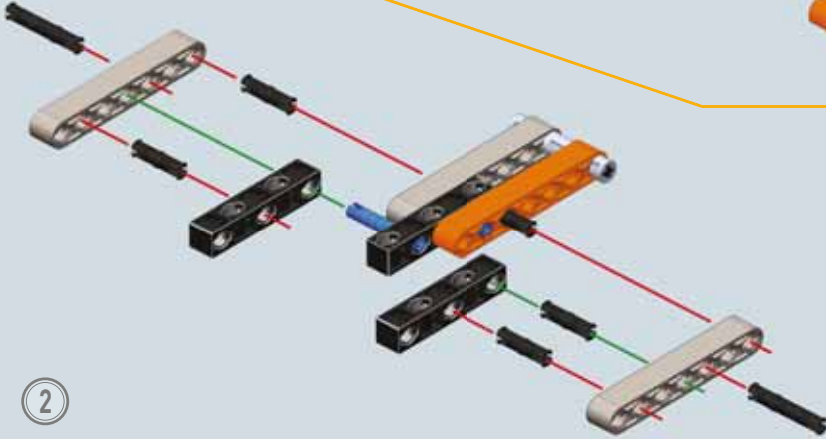
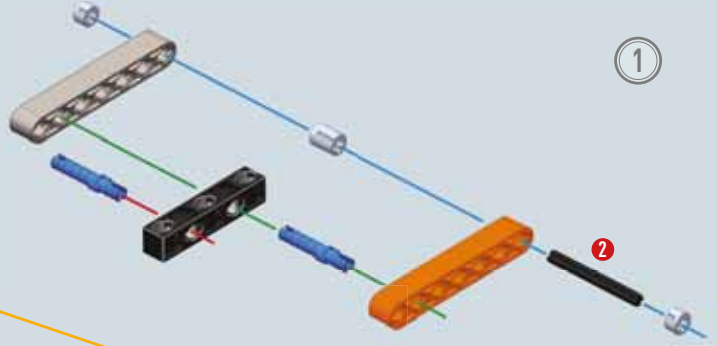
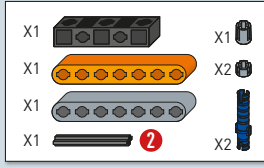

5

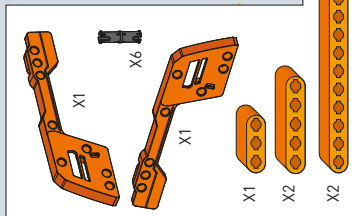
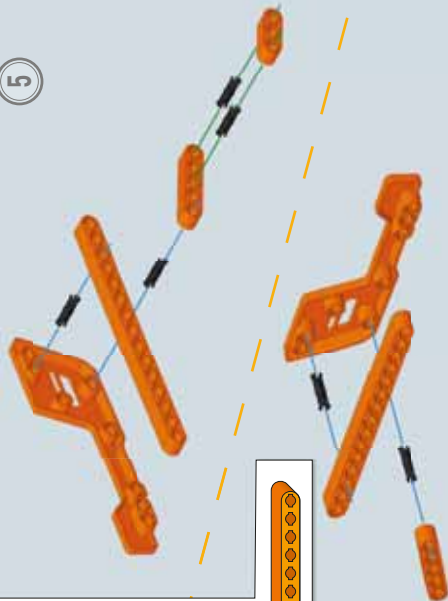

7



1:1

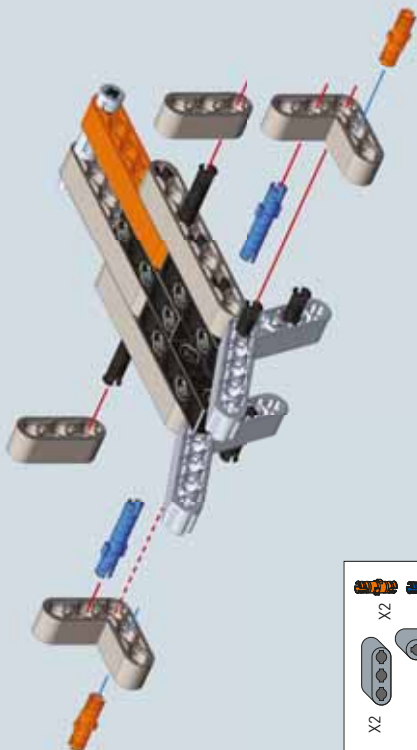

4

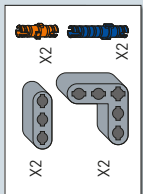

6

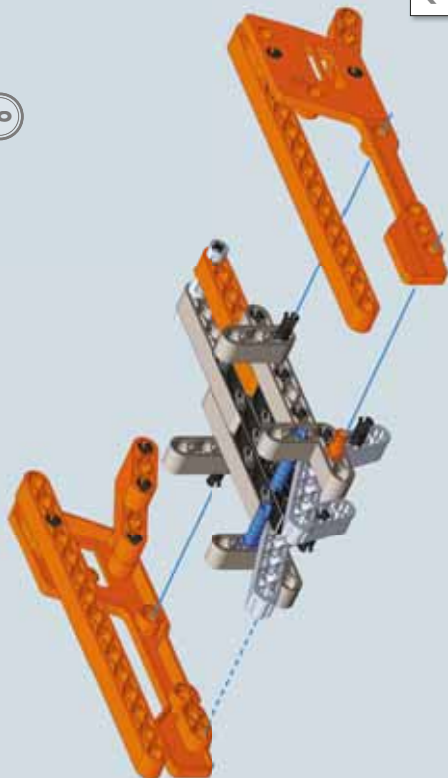

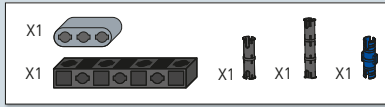

8

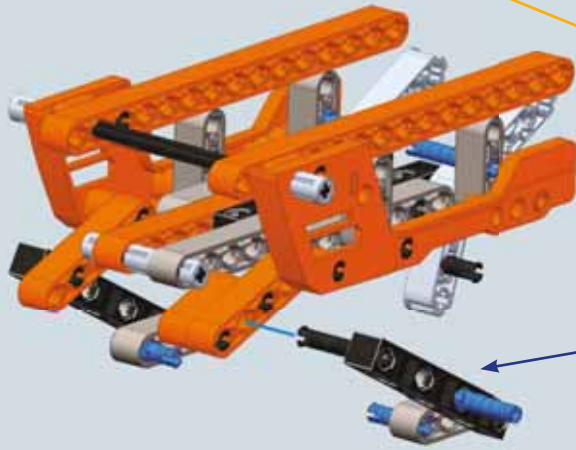
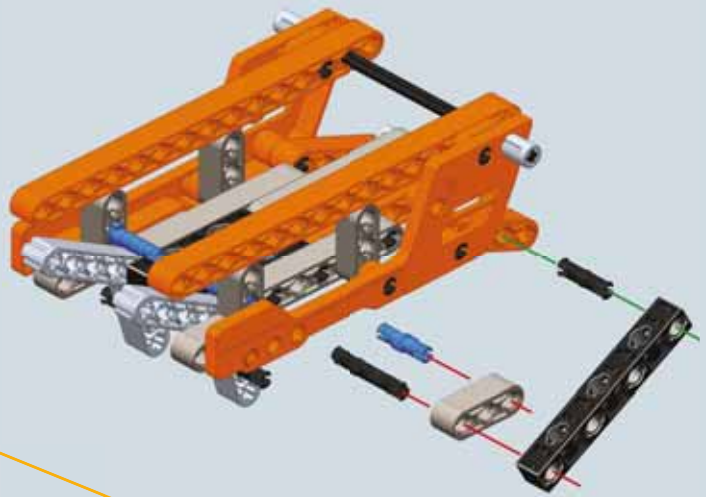

9

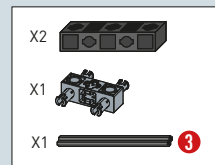
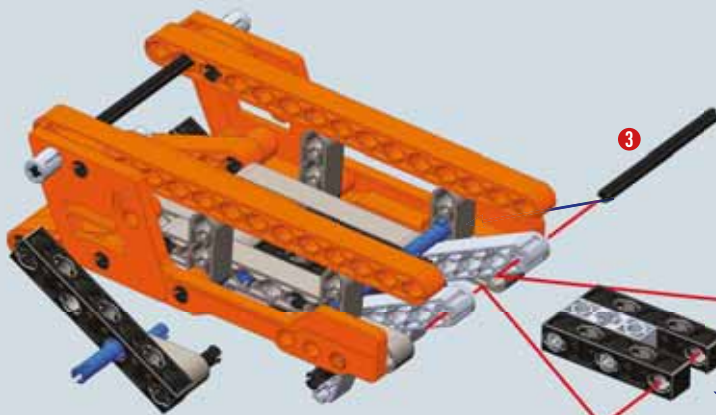
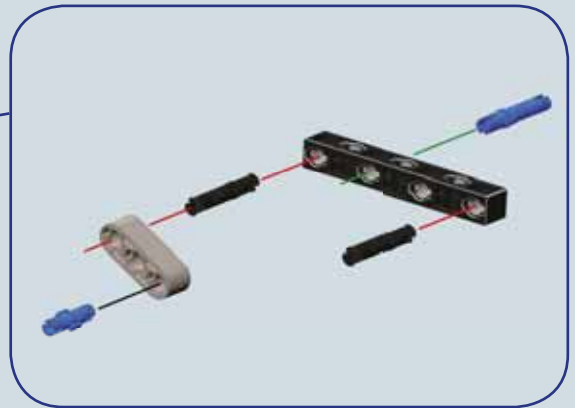

10

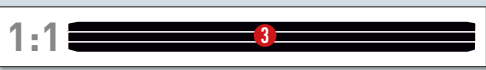

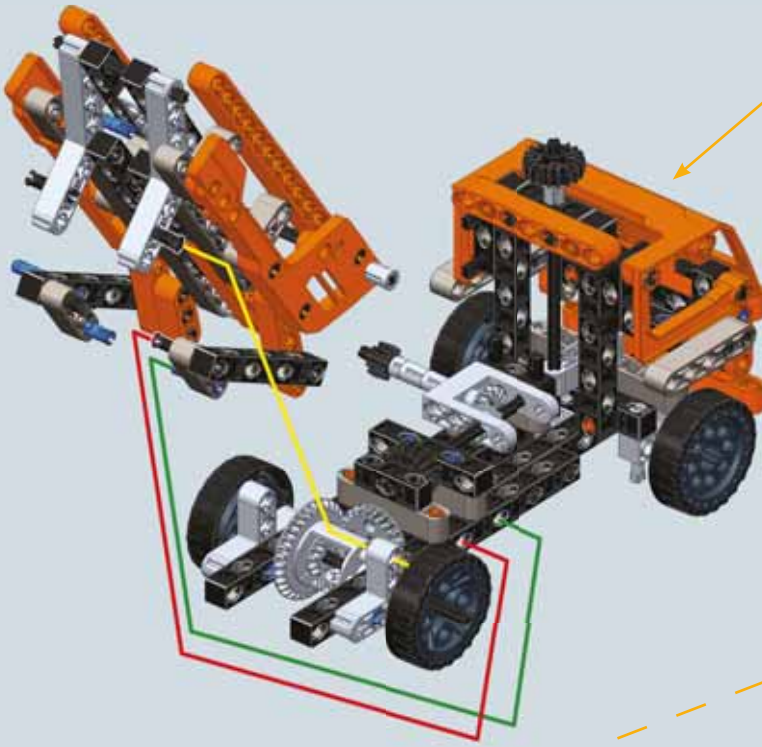

4. Etkinlikte kurulan model

11

Parçayı takmak için modeldeki parçayı sökmek gerekir.

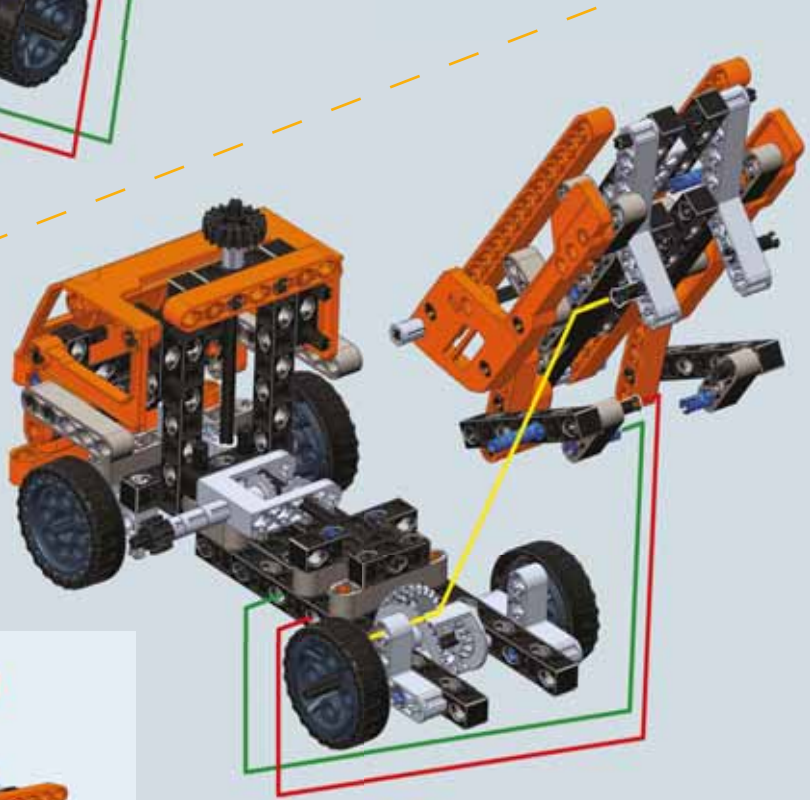

Montajı tamamlanmış model

# 7 Çekici kamyon



1

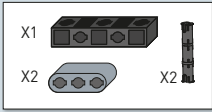
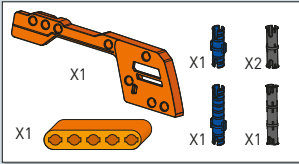
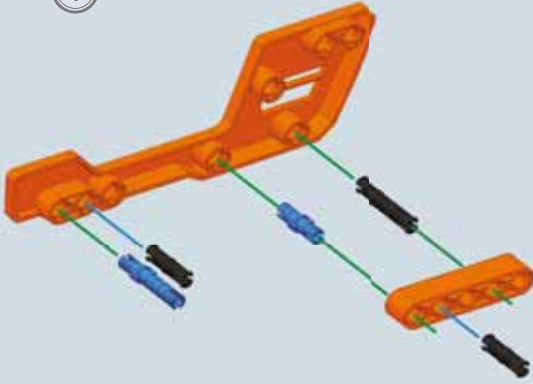

2

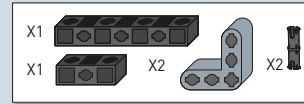
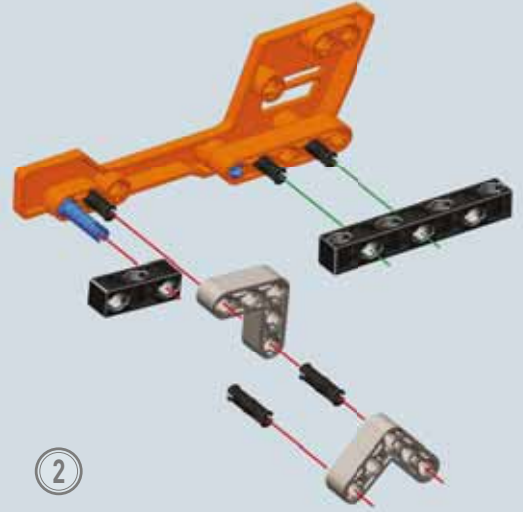

3



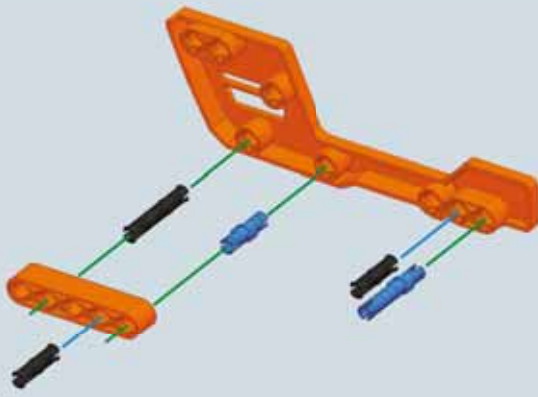

4

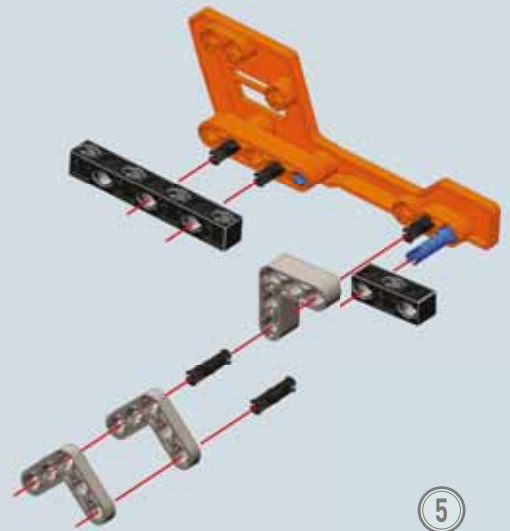
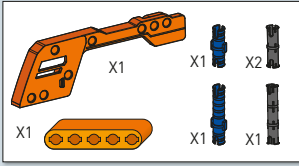

5

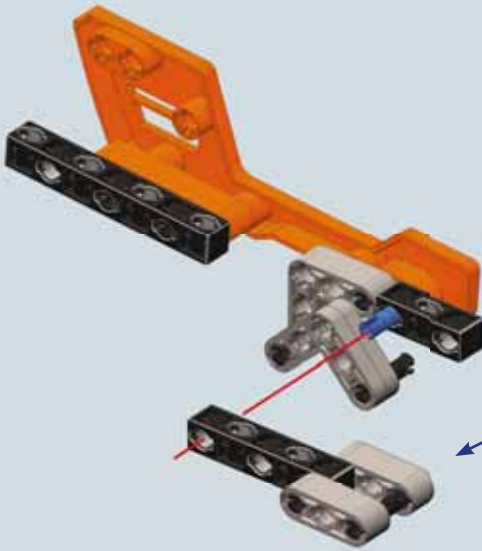
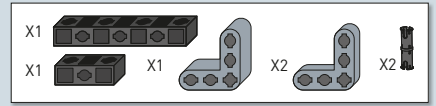

6

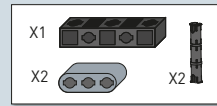
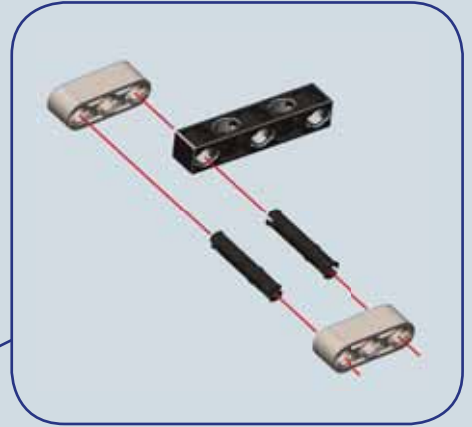

### Teknik unsurlar ve merak edilenler

Çekici kamyonlar, teknik bir arıza durumunda diğer motorlu taşıtları bir konumdan başka bir konuma çekmeye yardımcı olmak üzere tasarlanan yol yardımı taşıtlarıdır. Bu araçlar, çoğu durumda ulaşılması zor bölgelerde, genellikle kazadan dolayı yoldan çıkan taşıtları çekmek için kullanılır.



7

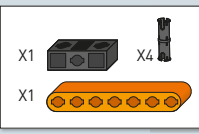

8

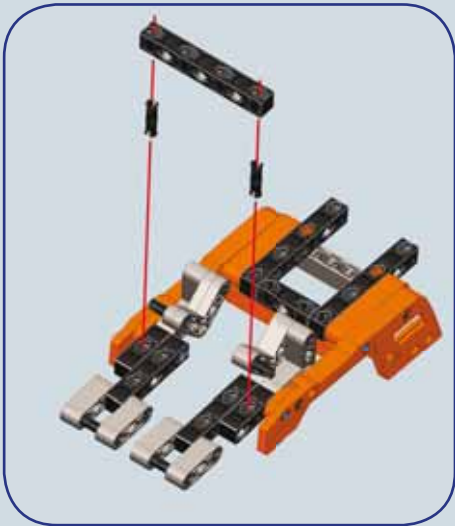

Parçayı takmak için modeldeki parçayı sökmek gerekir.

9



Montajı tamamlanmış model



4. Etkinlikte kurulan model



1

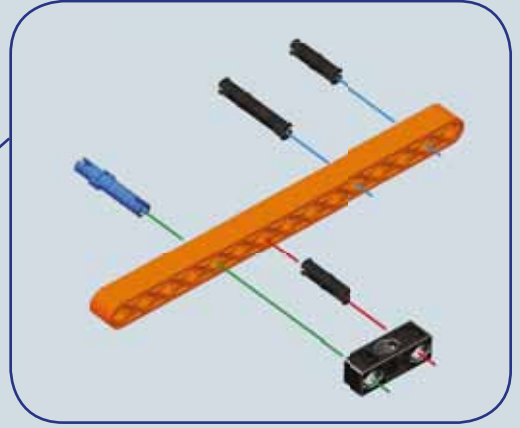
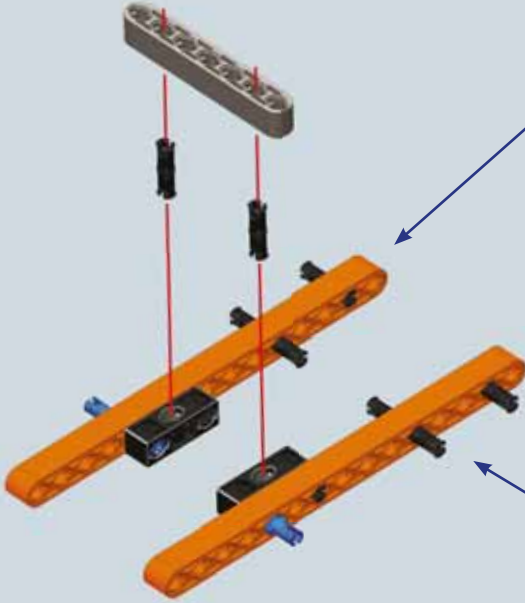

- X2
- X2
- X2
- X6
- X2
- X1

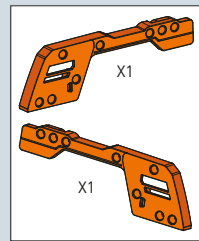

2

4. Etimlikte kurulan model



3

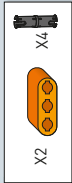
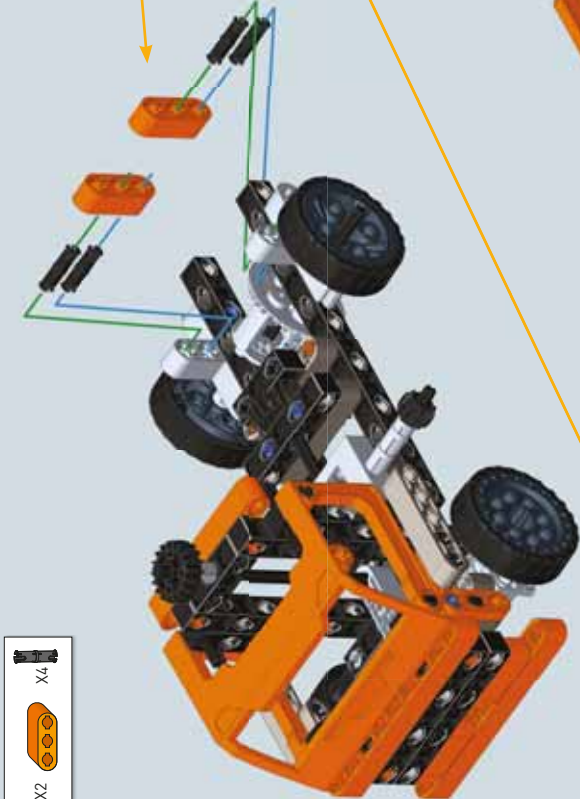

4

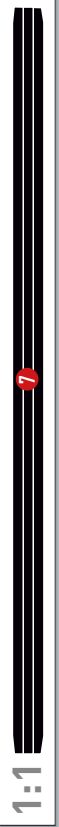
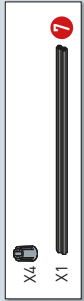
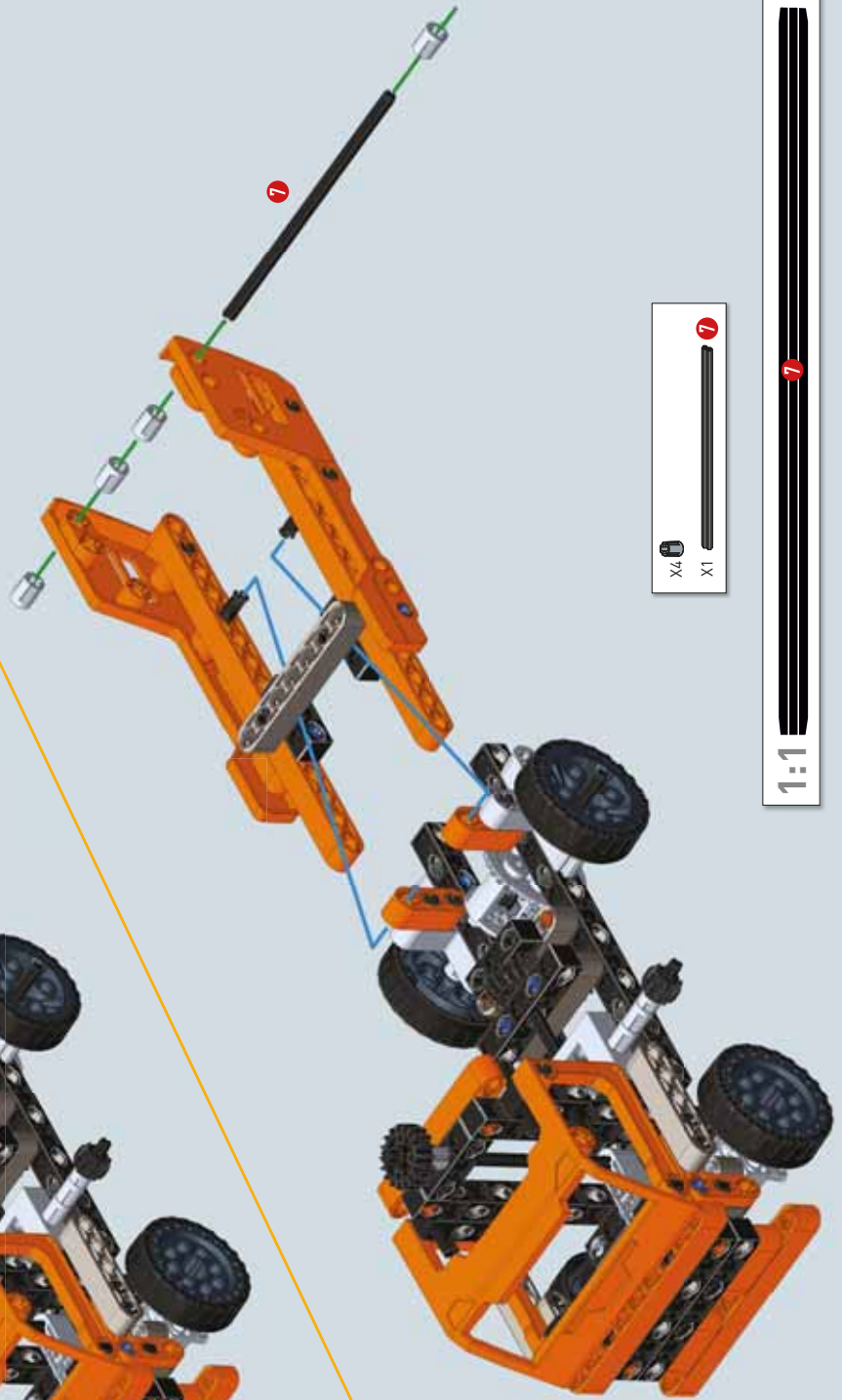

1:1

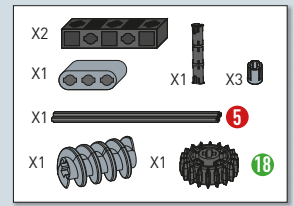

5

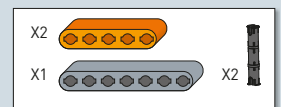
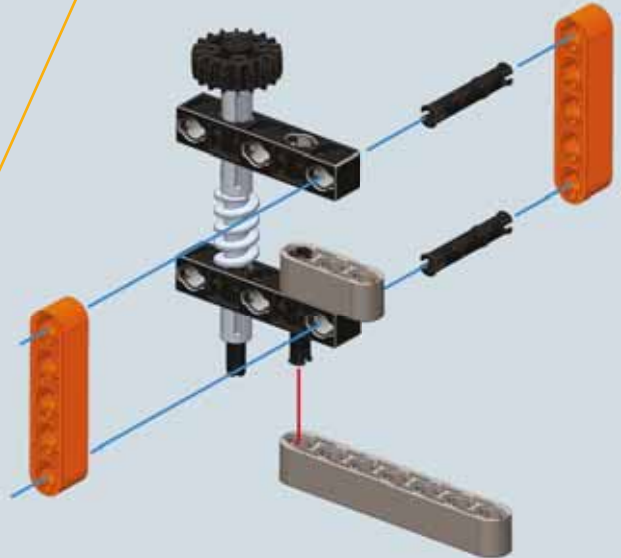

6

7

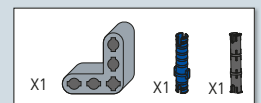
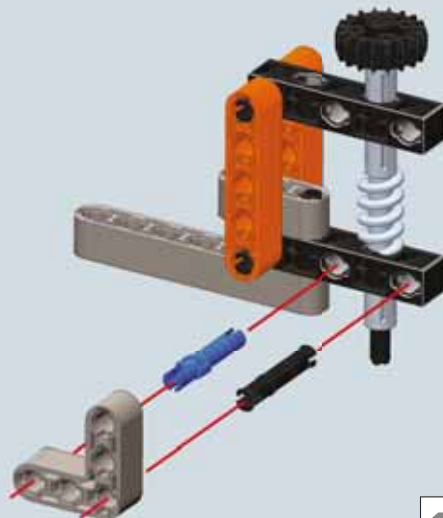

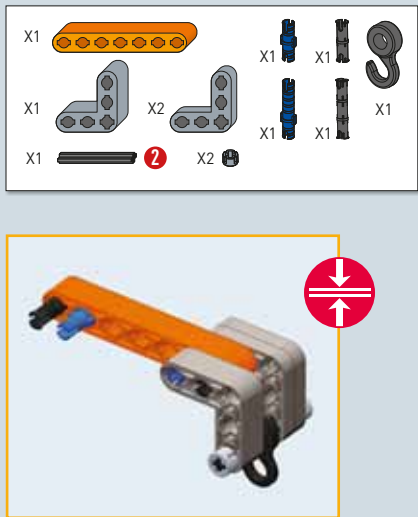
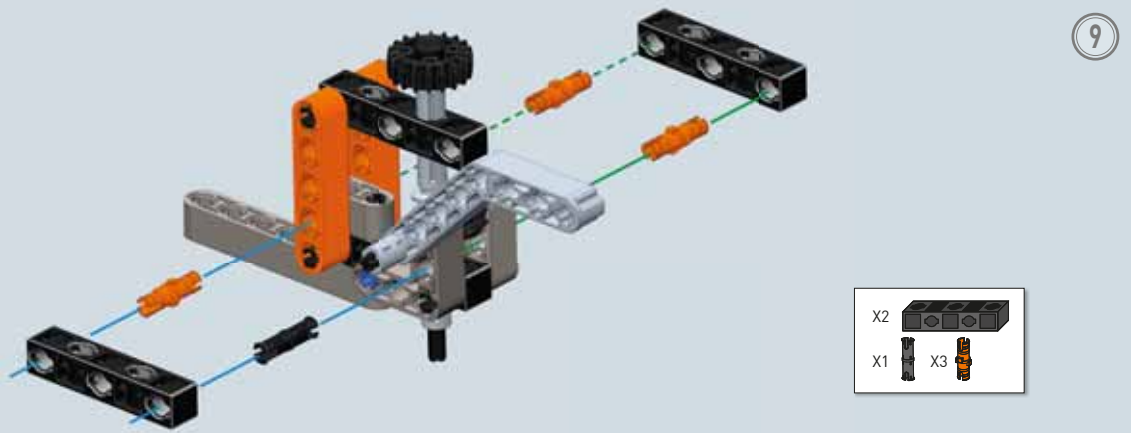
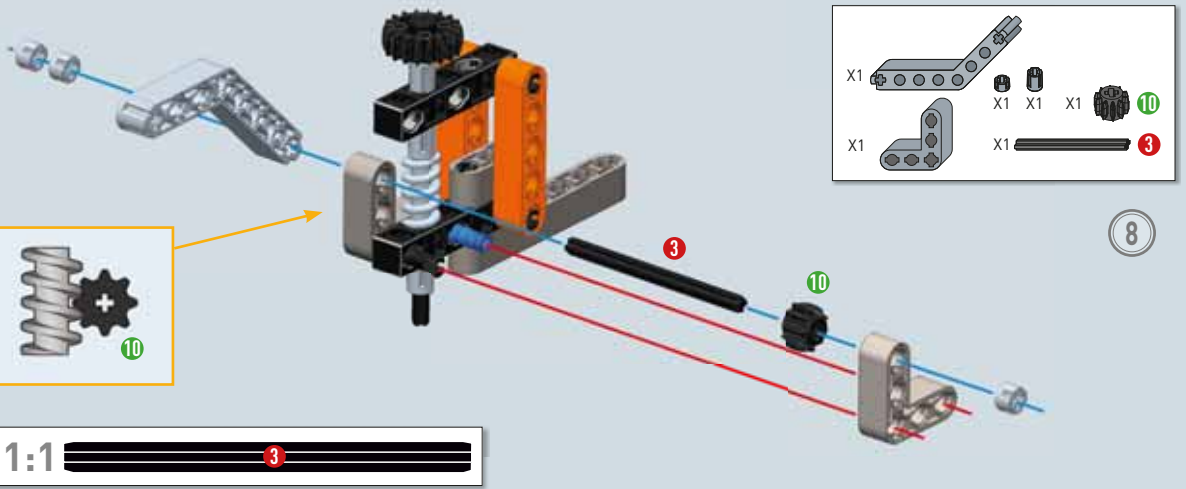

11

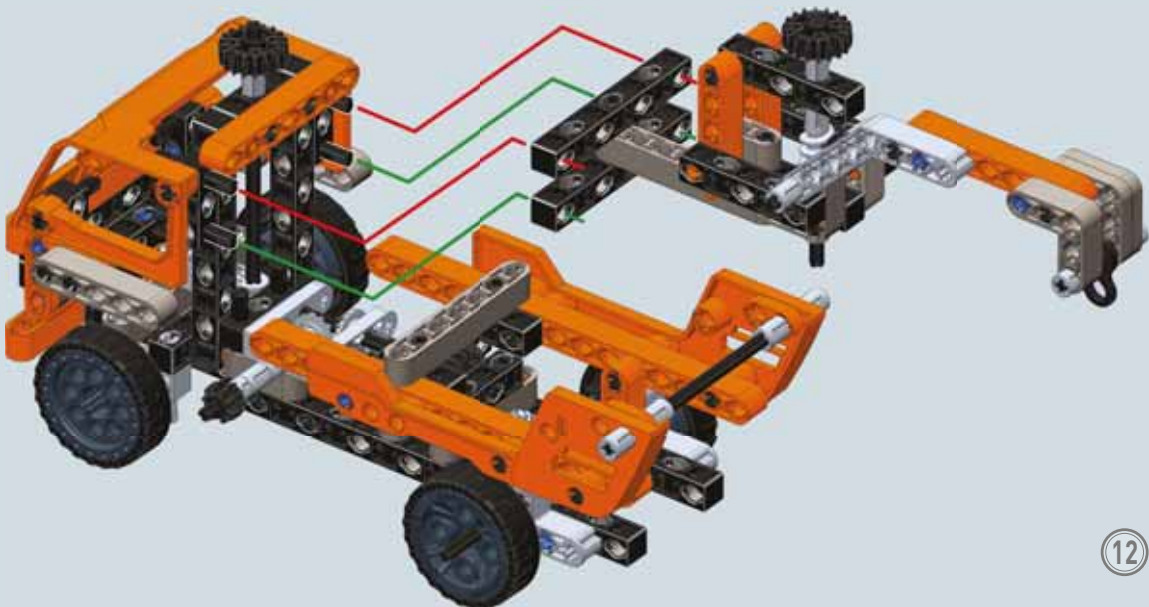
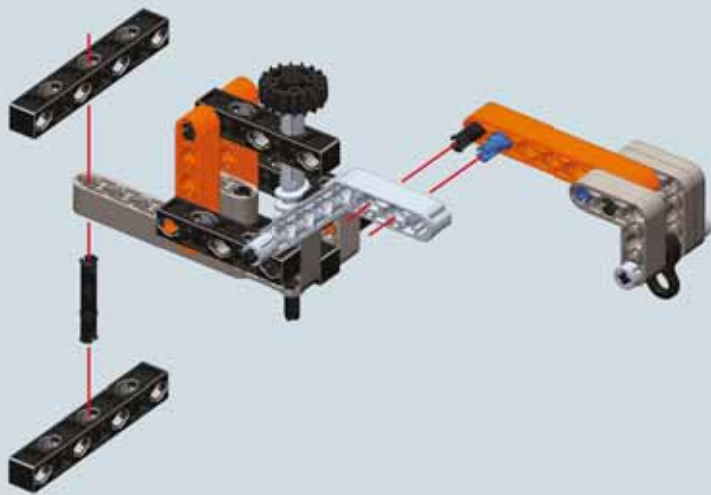

12

Montaji tamamlanmış model

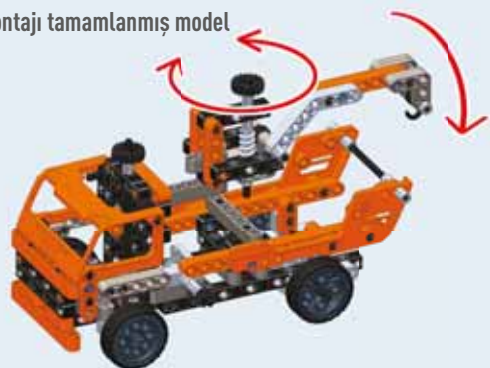



## Teknik unsurlar ve merak edilenler

"Kar temizleyici", daha çok bir taşıta monte edilen ve yol yüzeyinden kar ve buzu temizlemek için kullanılan araçlardan bahsederken kullanılır. Kar temizleyicinin ayırt edici aracı, kamyonların yanı sıra arazi taşıtlarına ve hatta raylardaki karları temizleme amacıyla trenlere monte edilebilen çelik yassı levhadır.

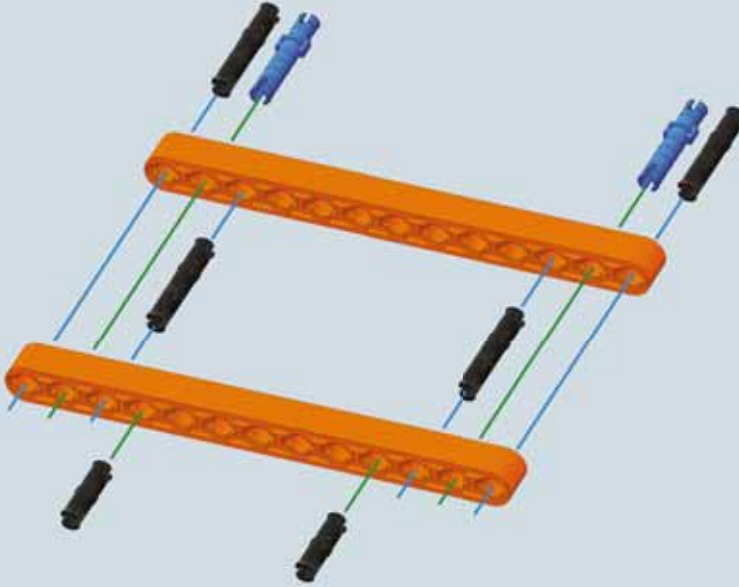

1

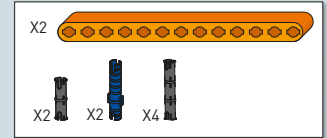

2

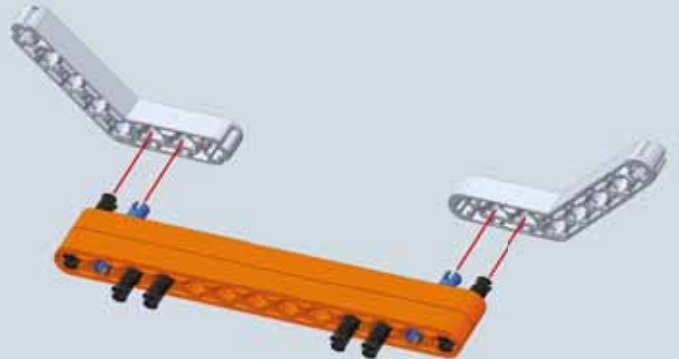
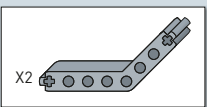

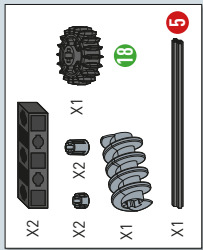

4

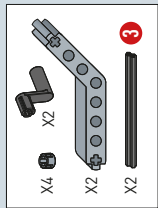
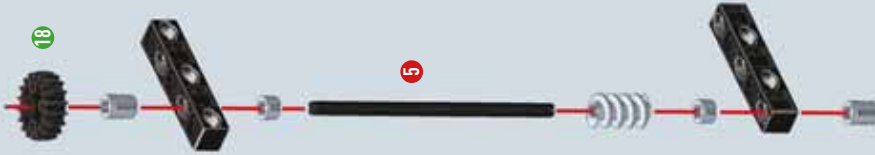

3

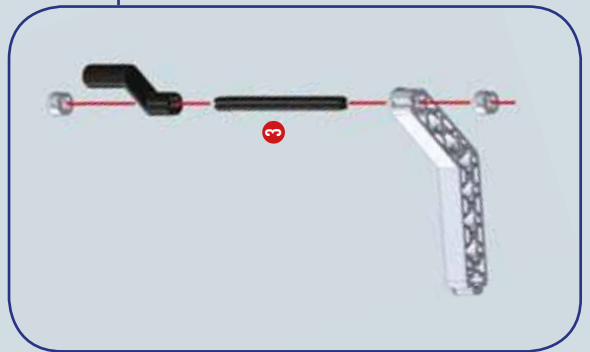
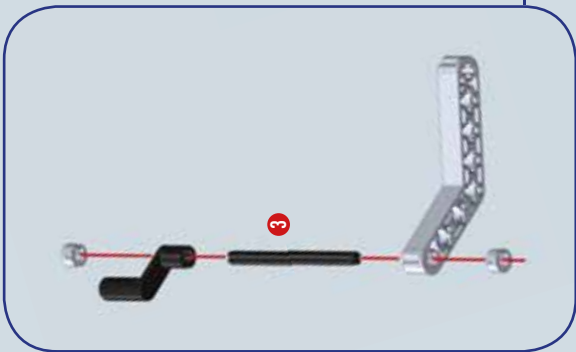
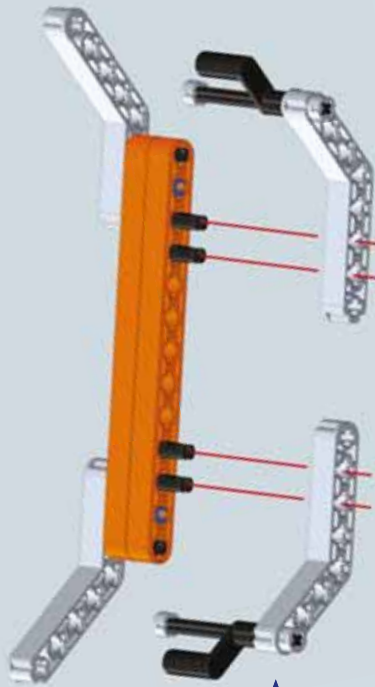



5

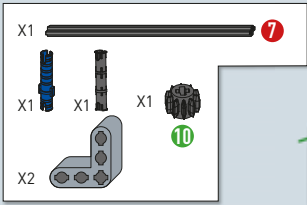
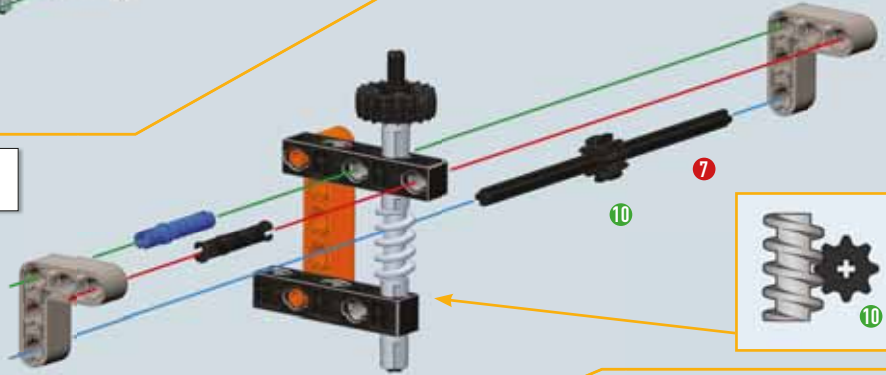
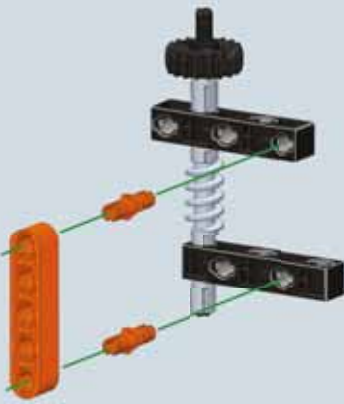
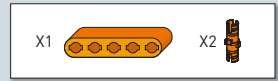

6

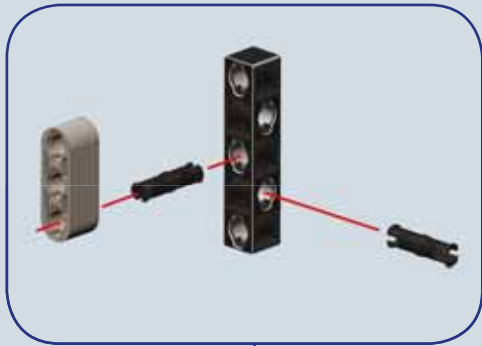

7

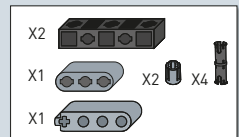
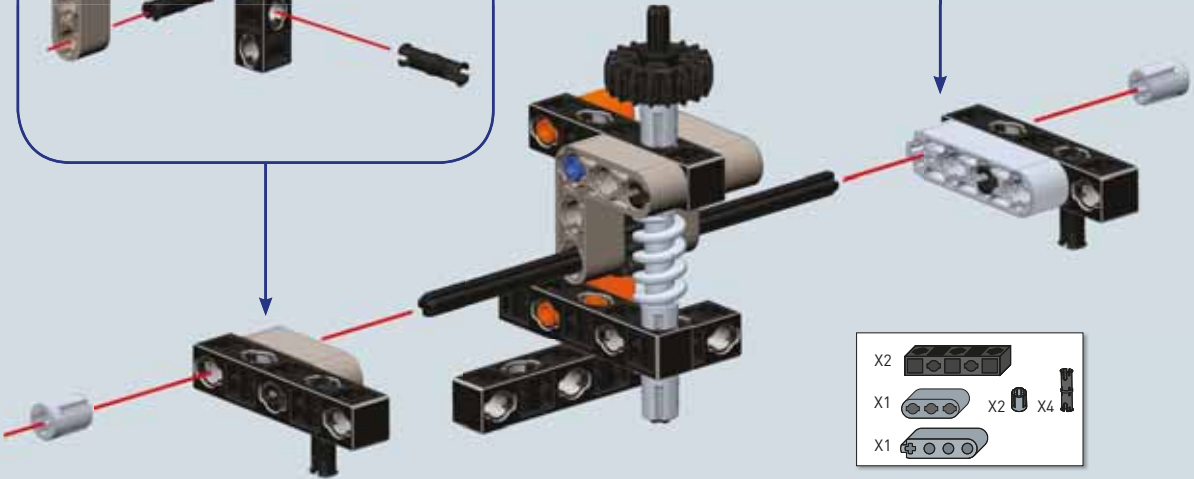

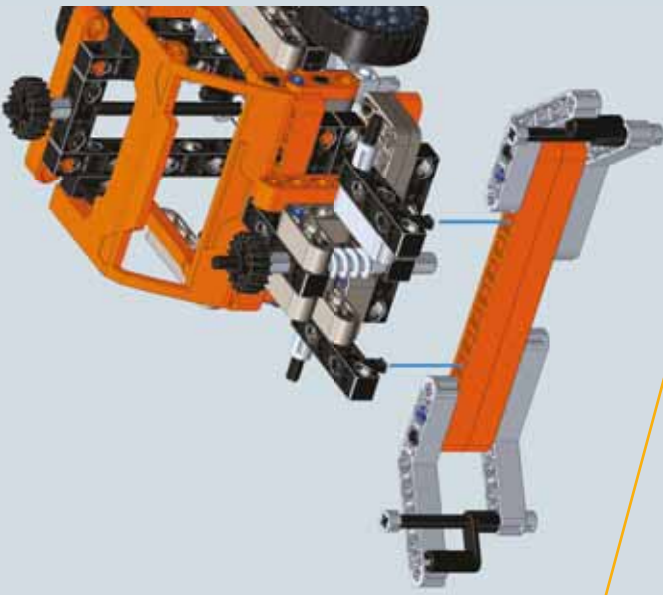

9

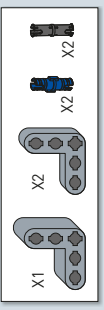

8

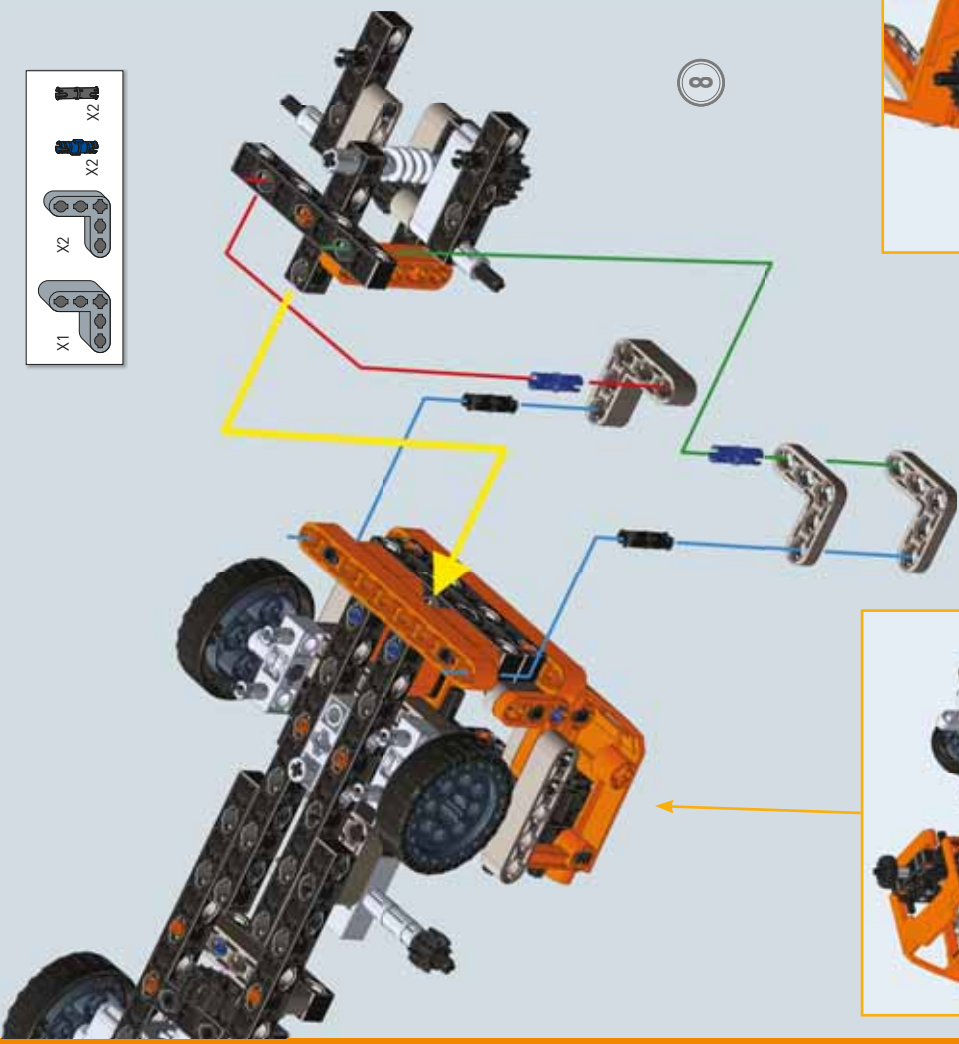

4. Etkinlikte kurulan model

10



X1			
X1		X1	X3
	X1		

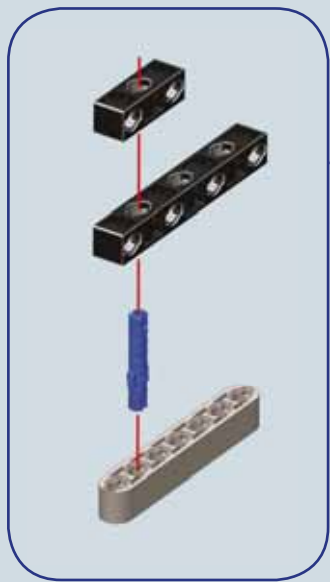

11

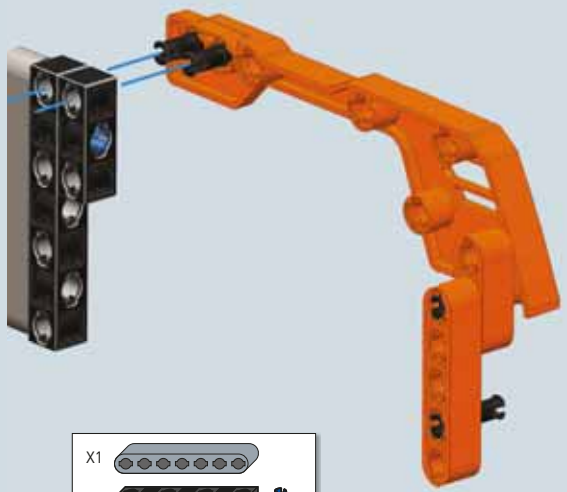

X1		
X1		
X1		

12

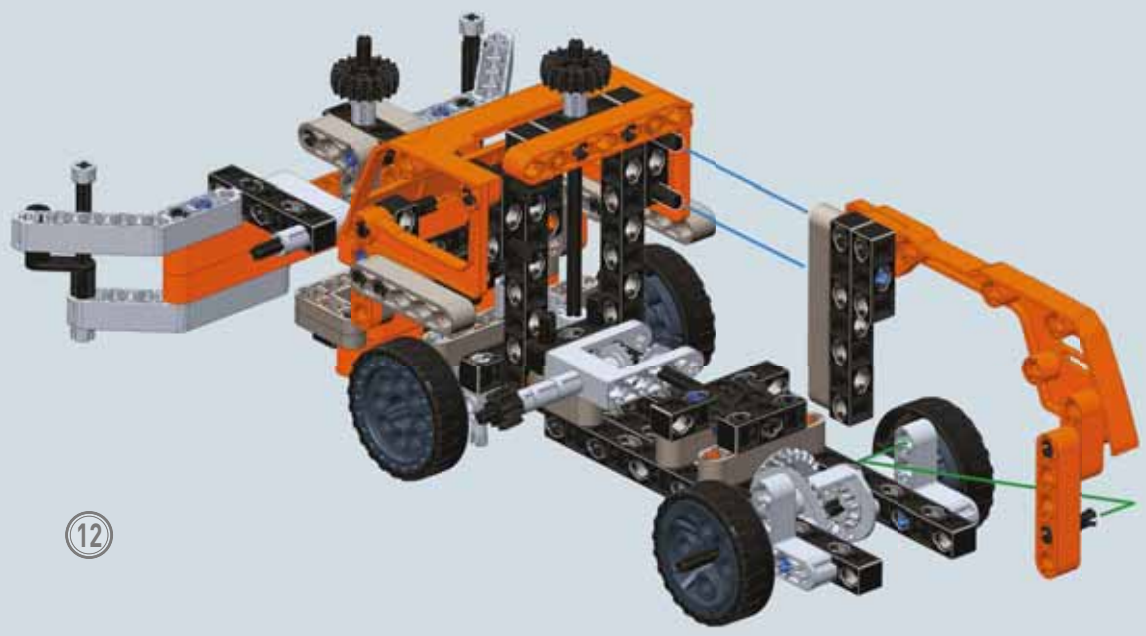

Montajı tamamlanmış model



14

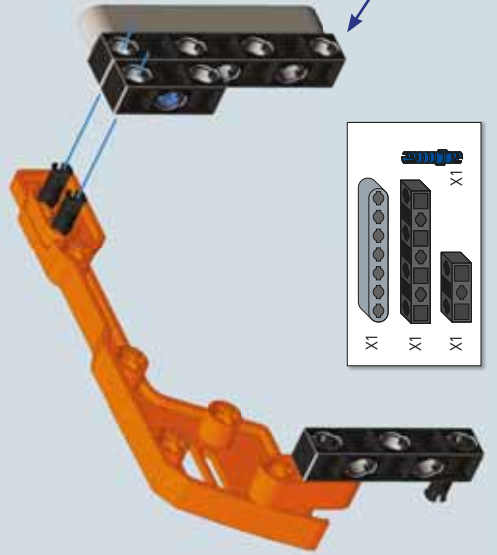
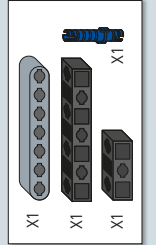
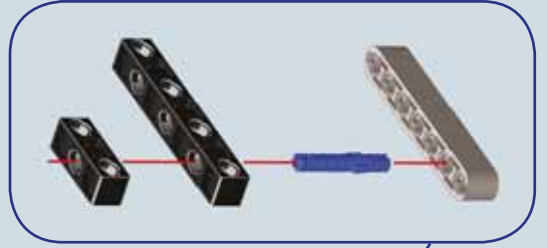

15

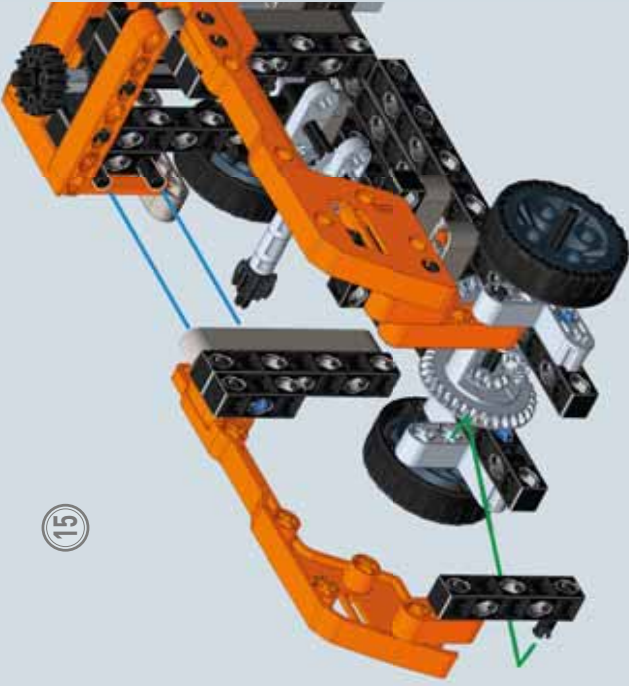

13

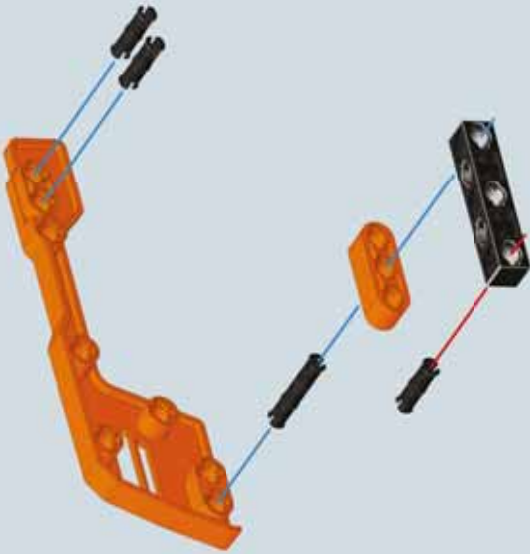
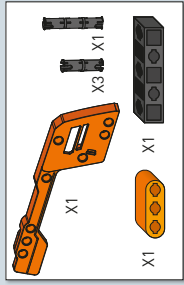

## 10 Amerikan kamyonu



### Teknik unsurlar ve merak edilenler

Amerikan kamyonları, uzun burunlarıyla kolaylıkla ayırt edilebilir. Bu araçlar, Avrupa trafik kurallarında belirtilen kısıtlamalardan muaf olduklarından ve uzun mesafeler katettiklerinden, seyyar evlere benzer.

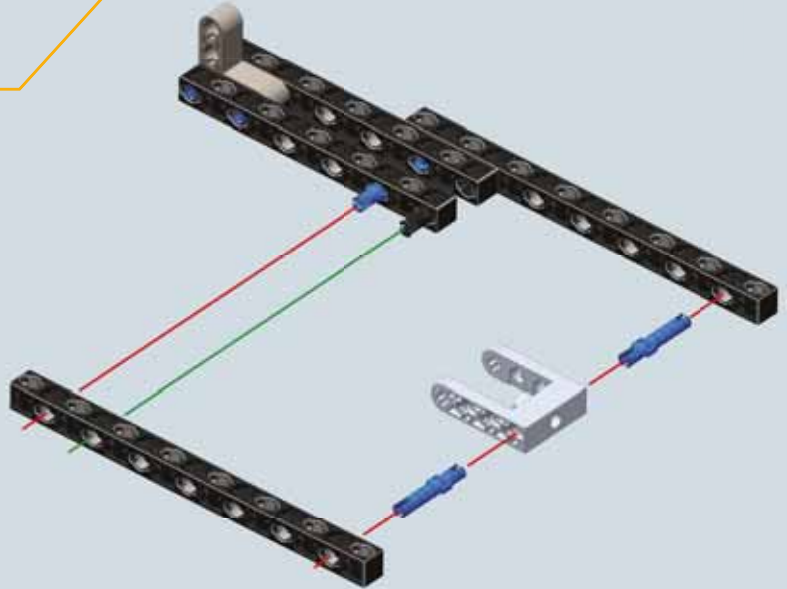
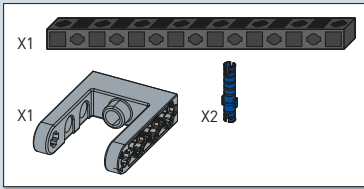
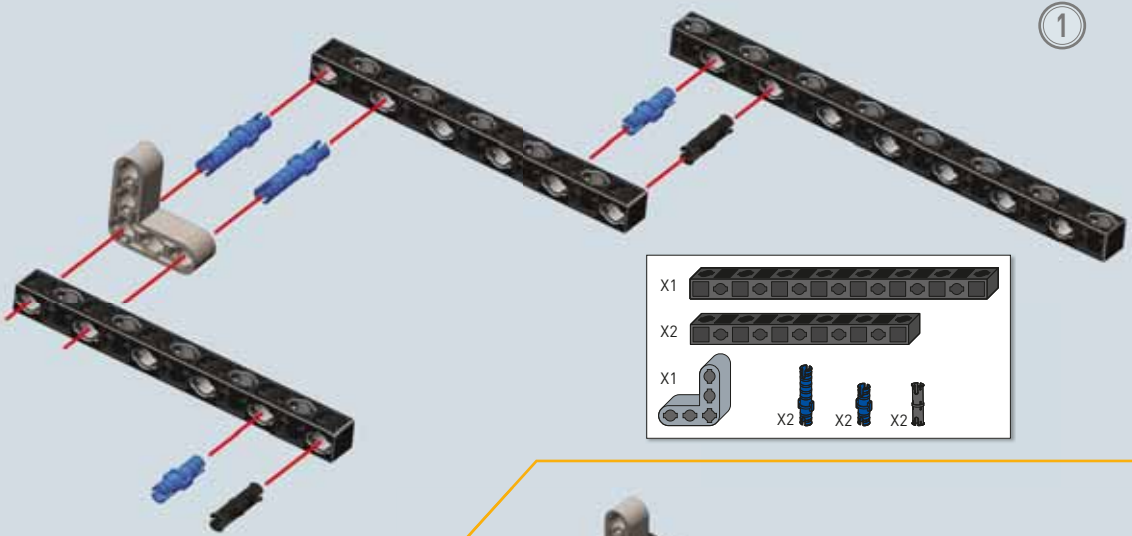

3

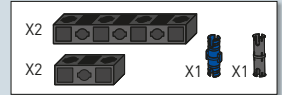
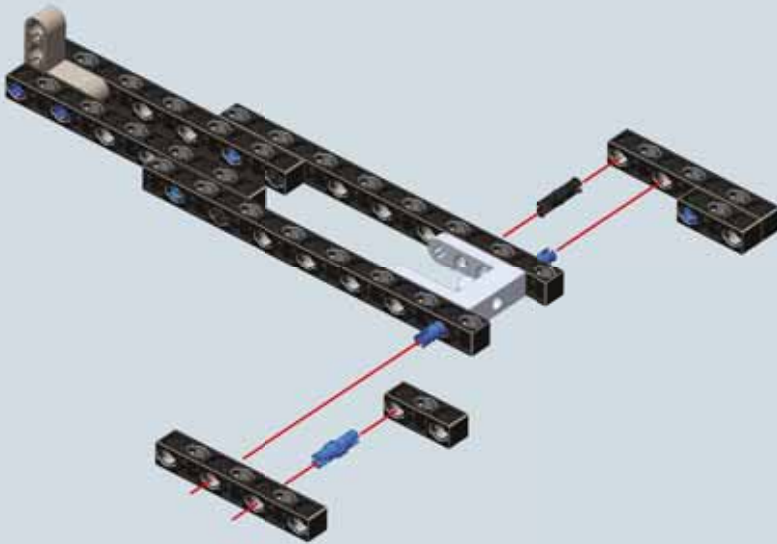

4

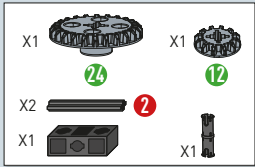
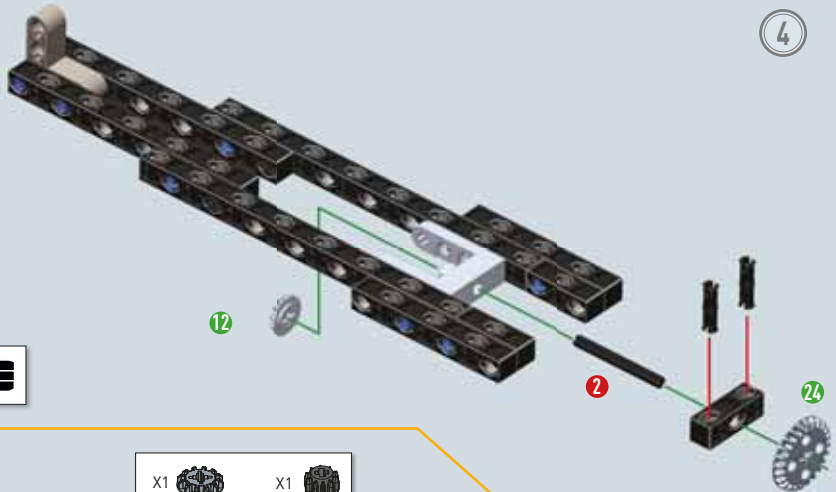

5

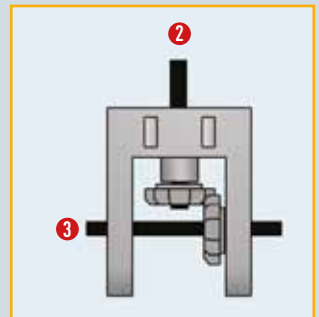
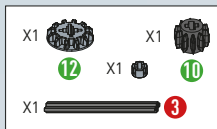
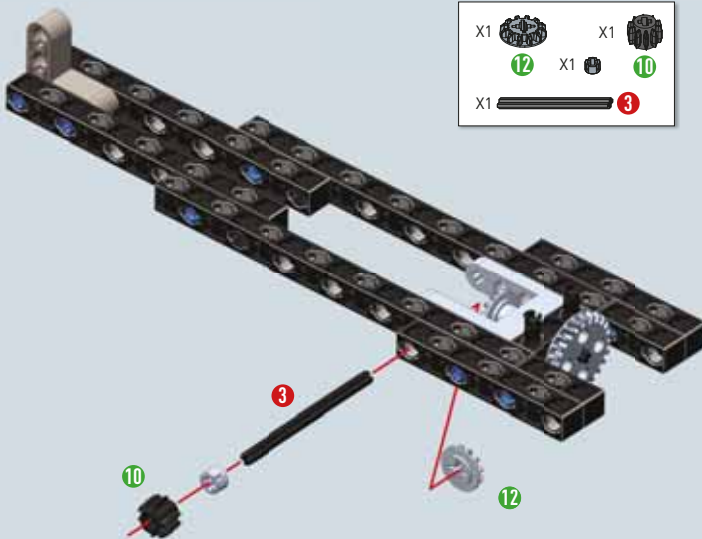

6

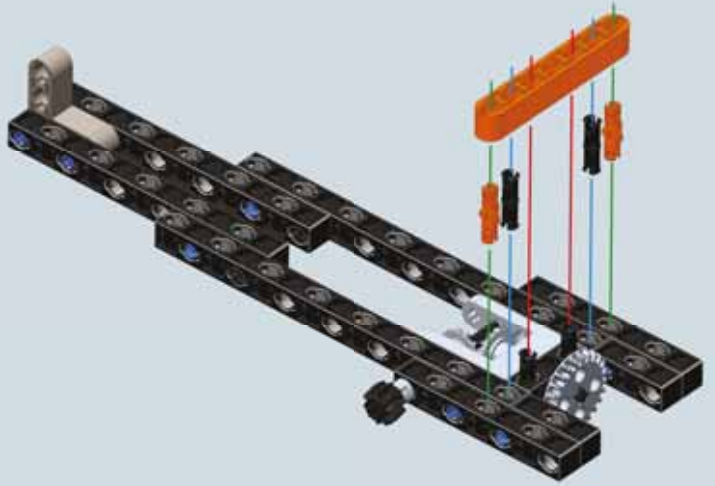

- X1
- X2
- X2

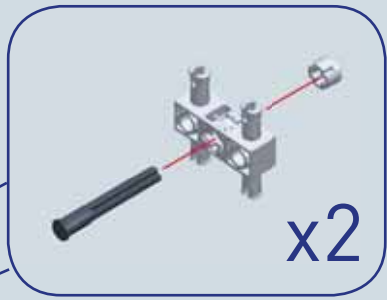
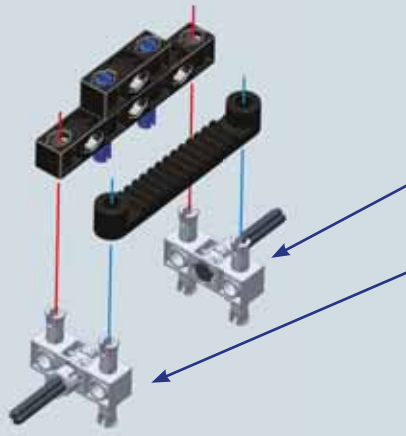
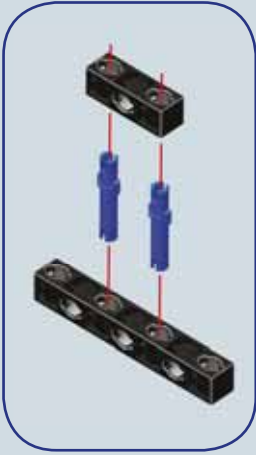

- X2
- X1
- X1
- X1
- X2
- X2
- X2
- X1

7

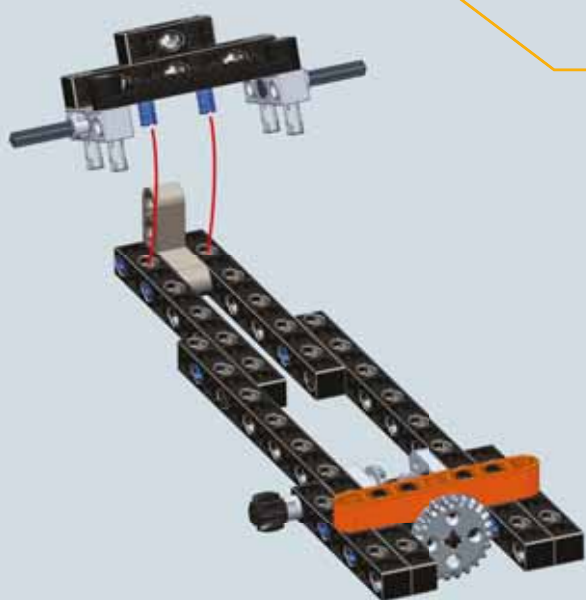

8

9

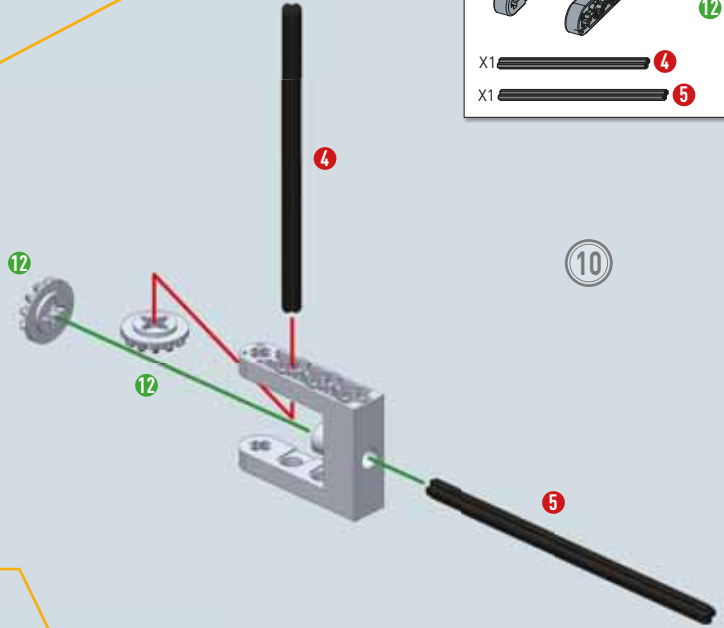
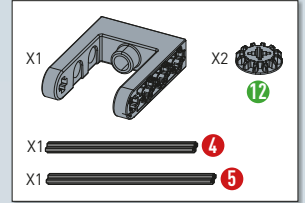
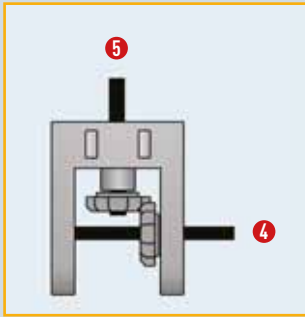
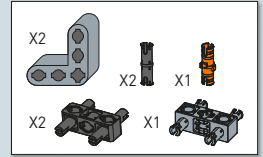
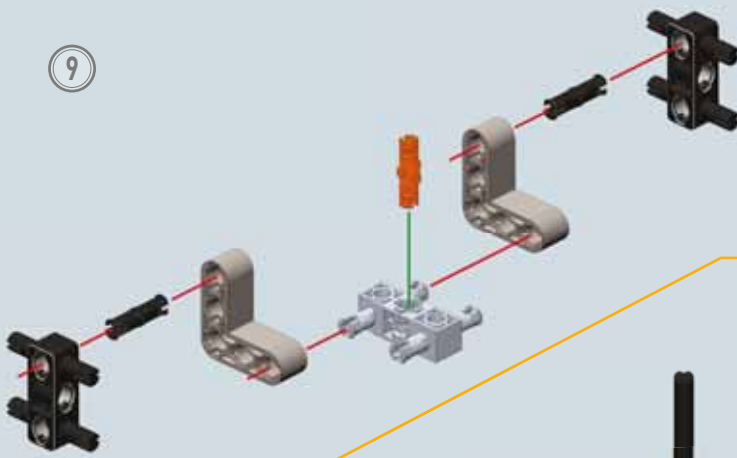

10

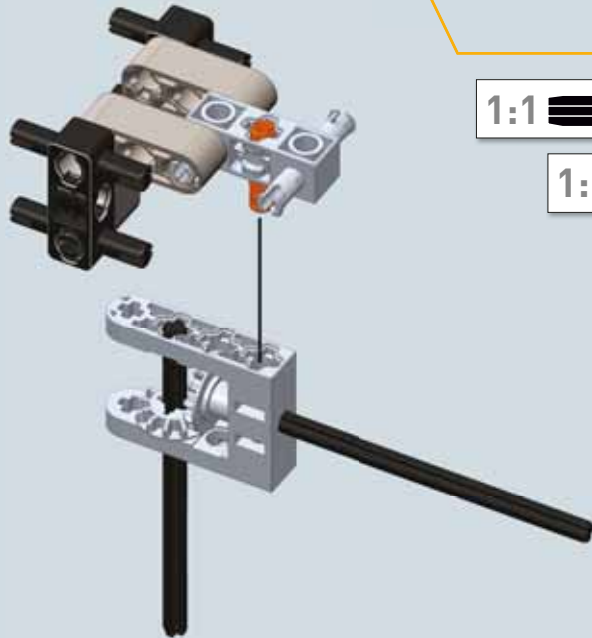

11



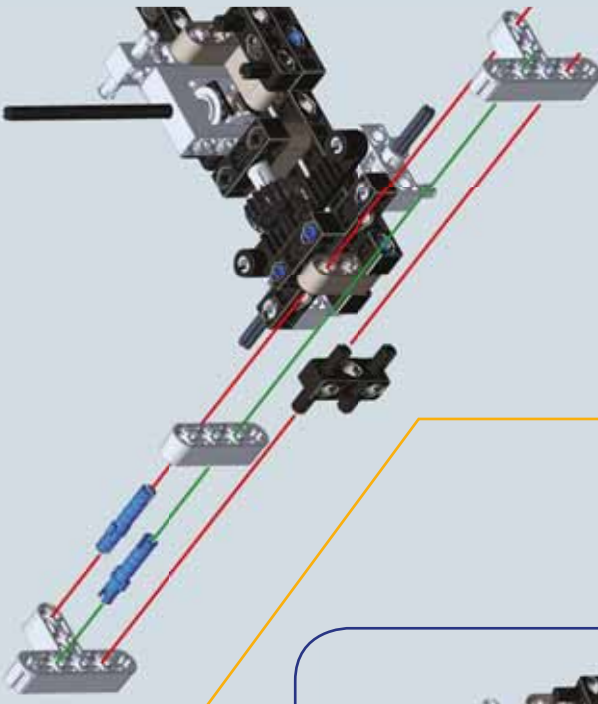

13

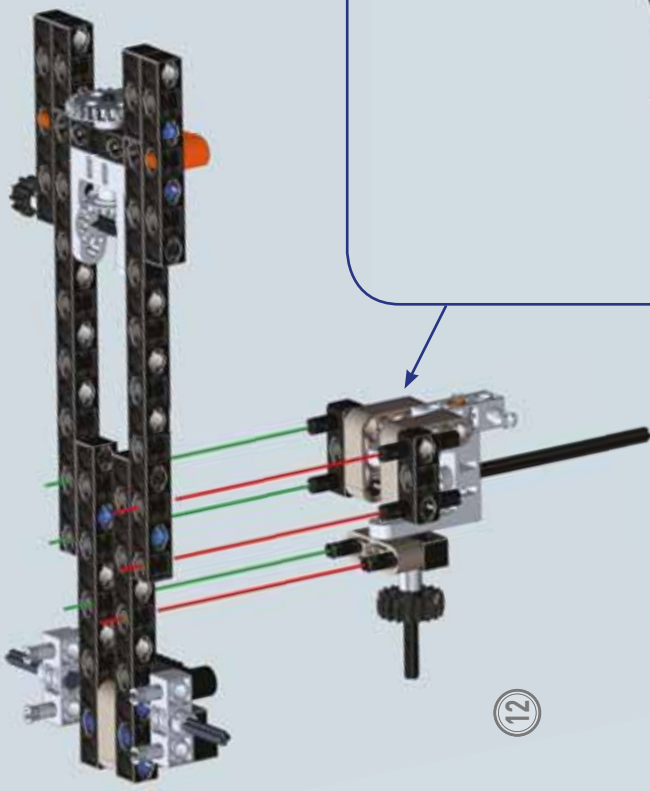
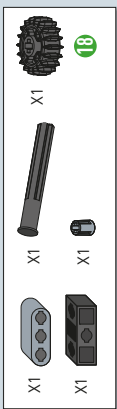
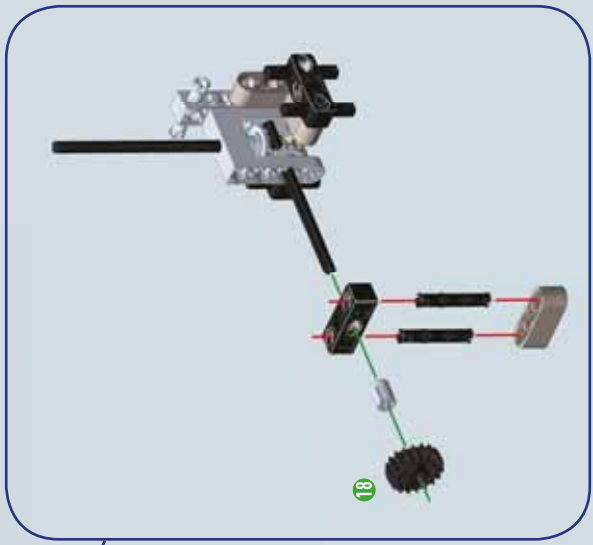
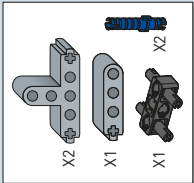

12

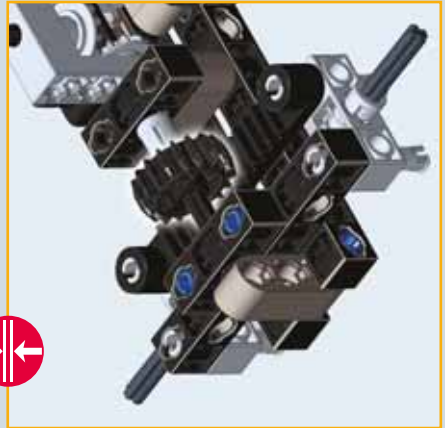

14

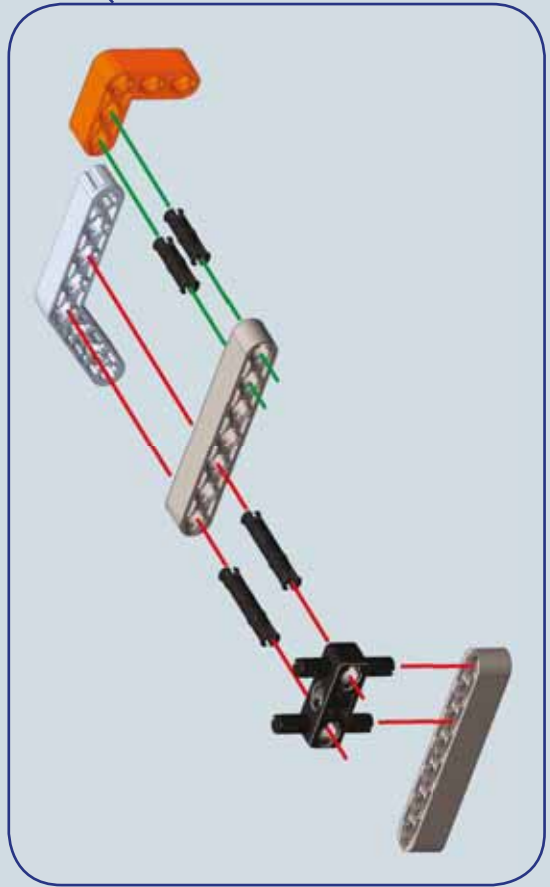
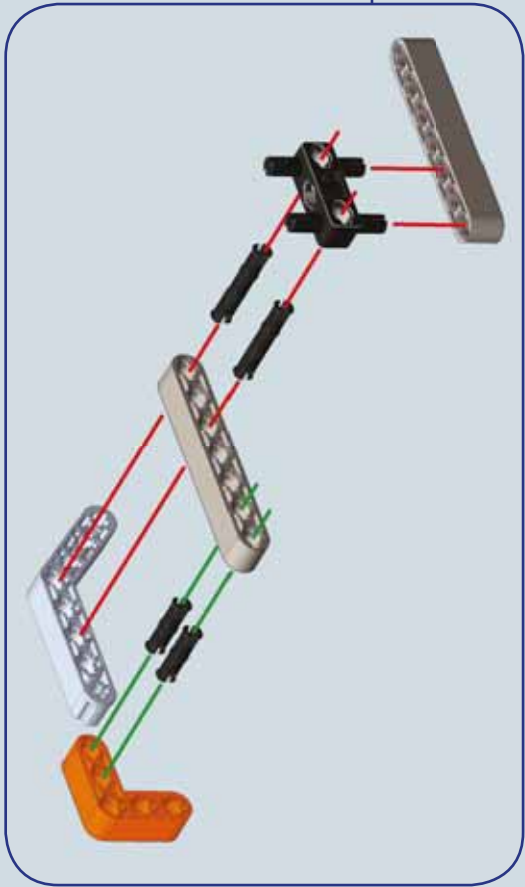
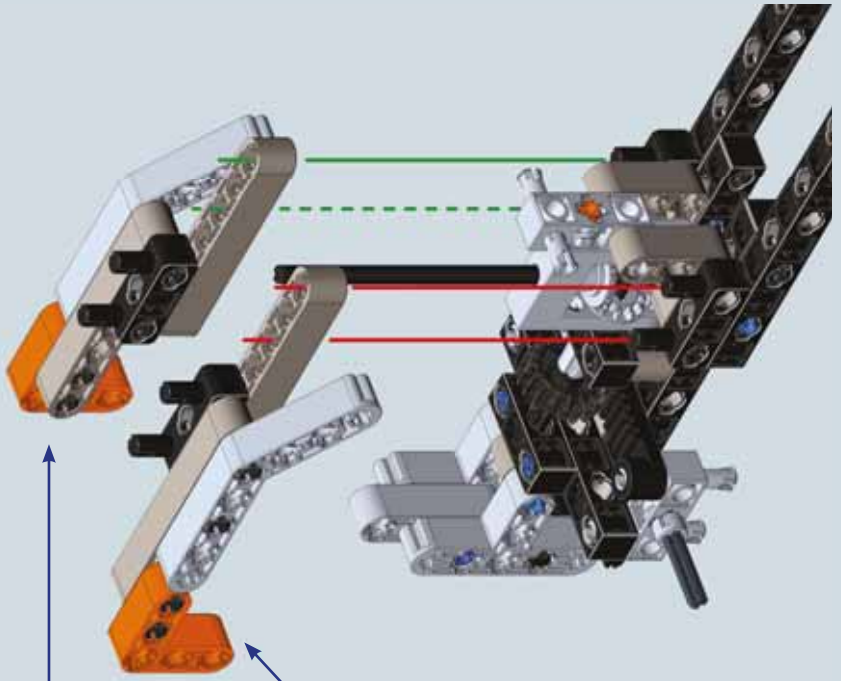
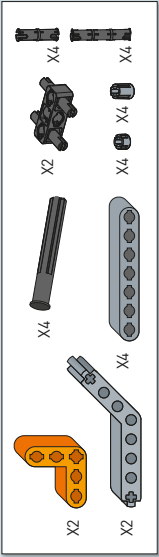

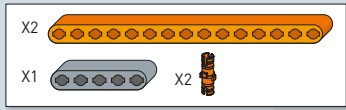

15

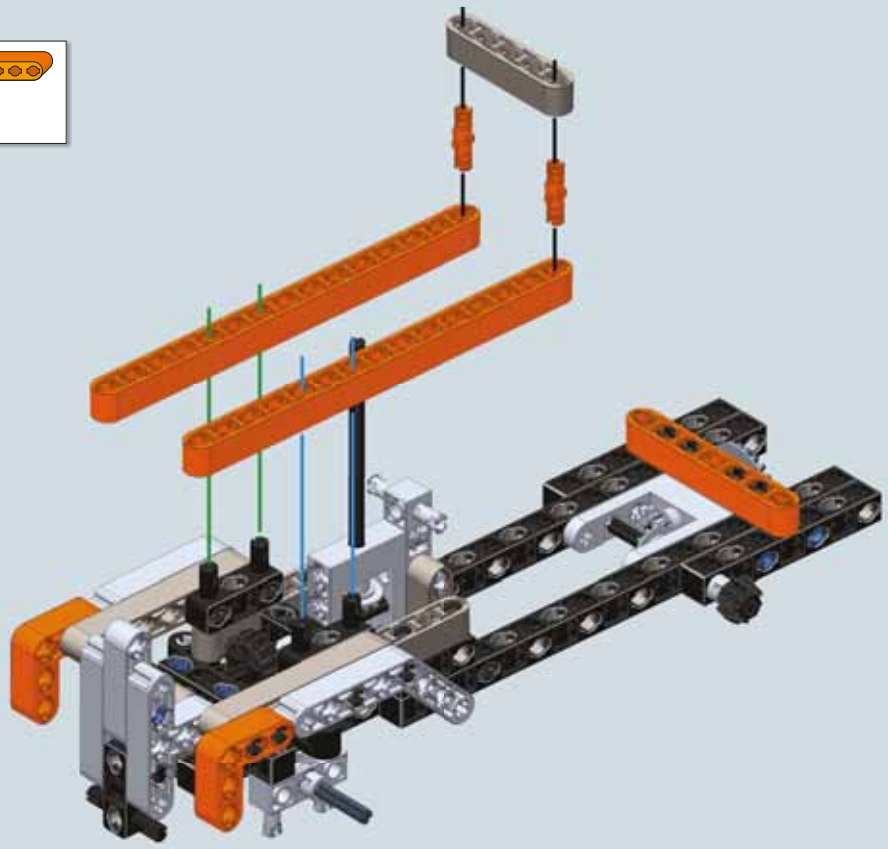

16

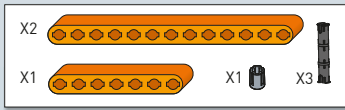
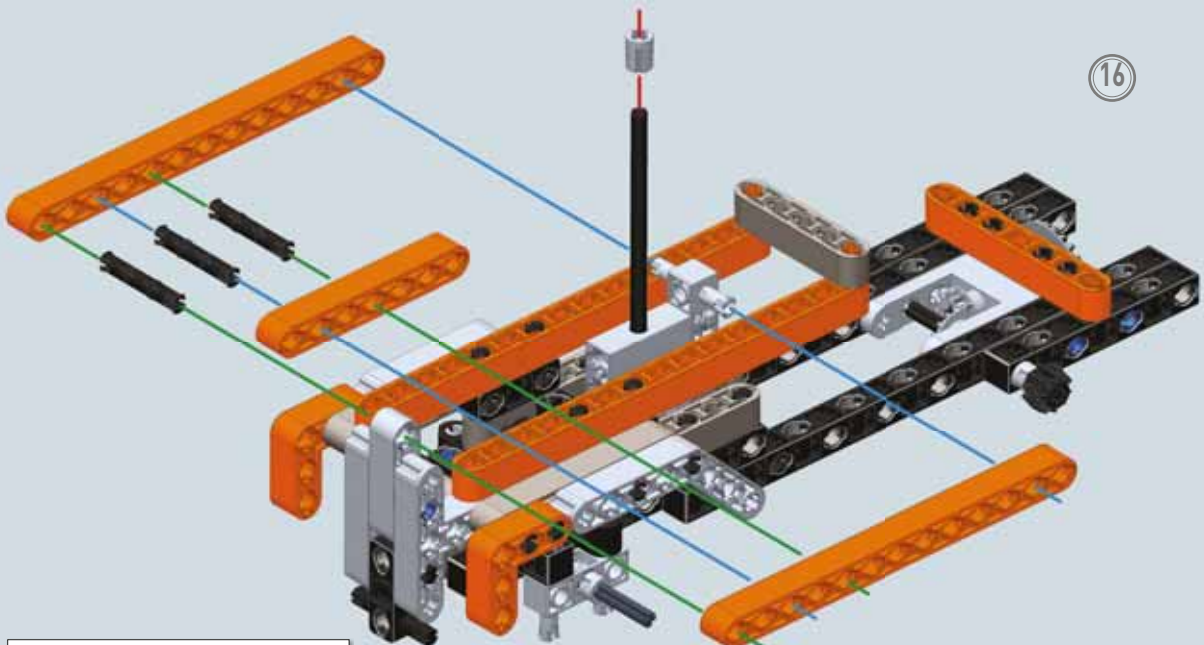

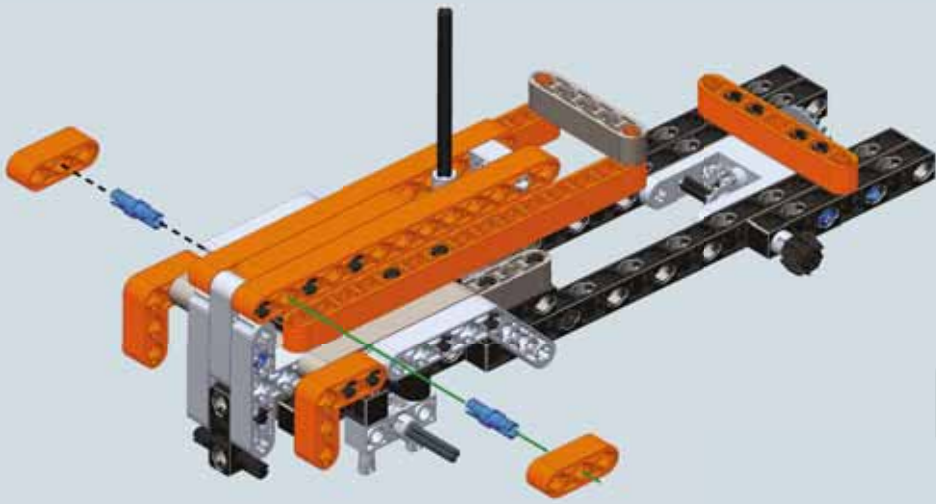

17

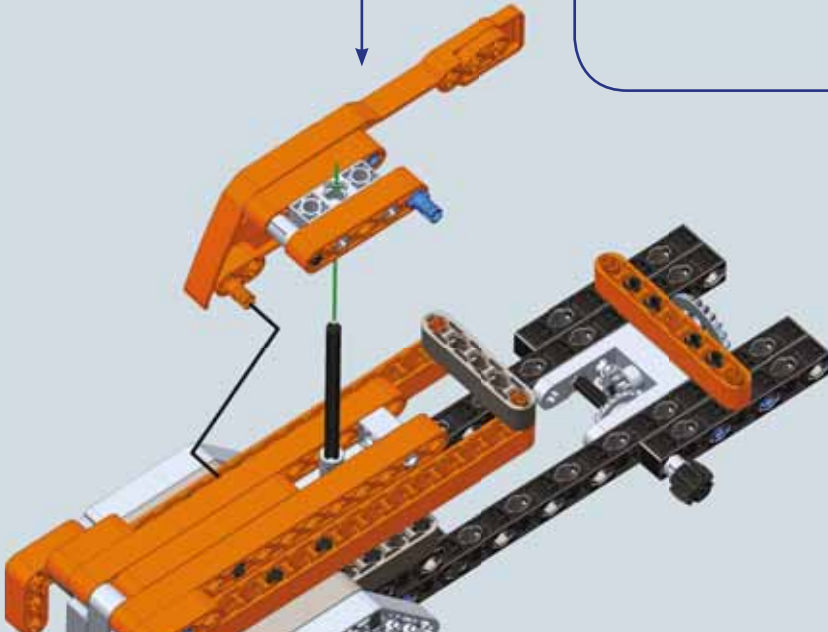
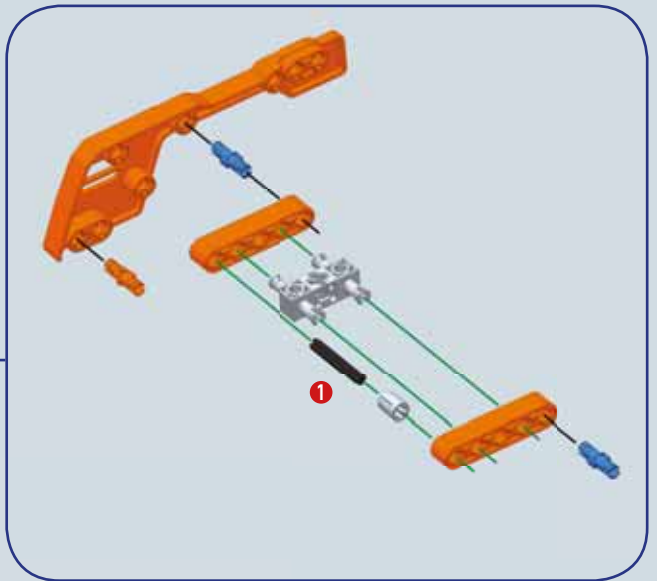
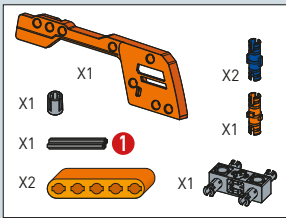

18



19

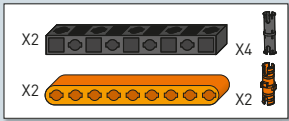
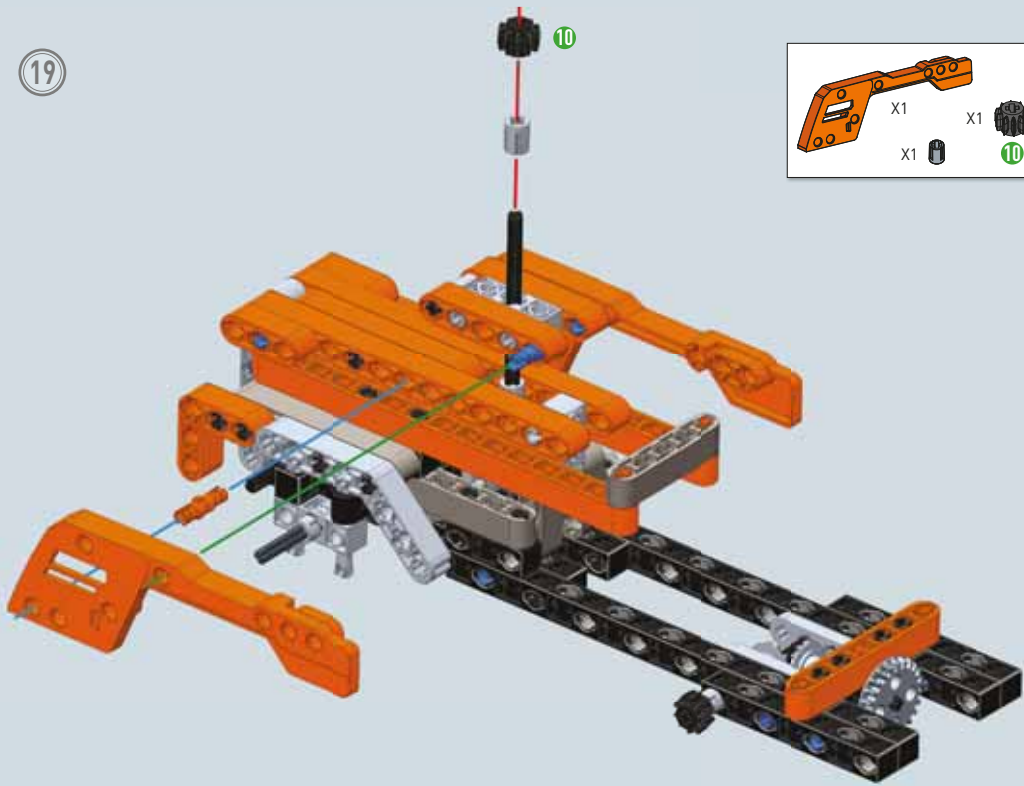

20

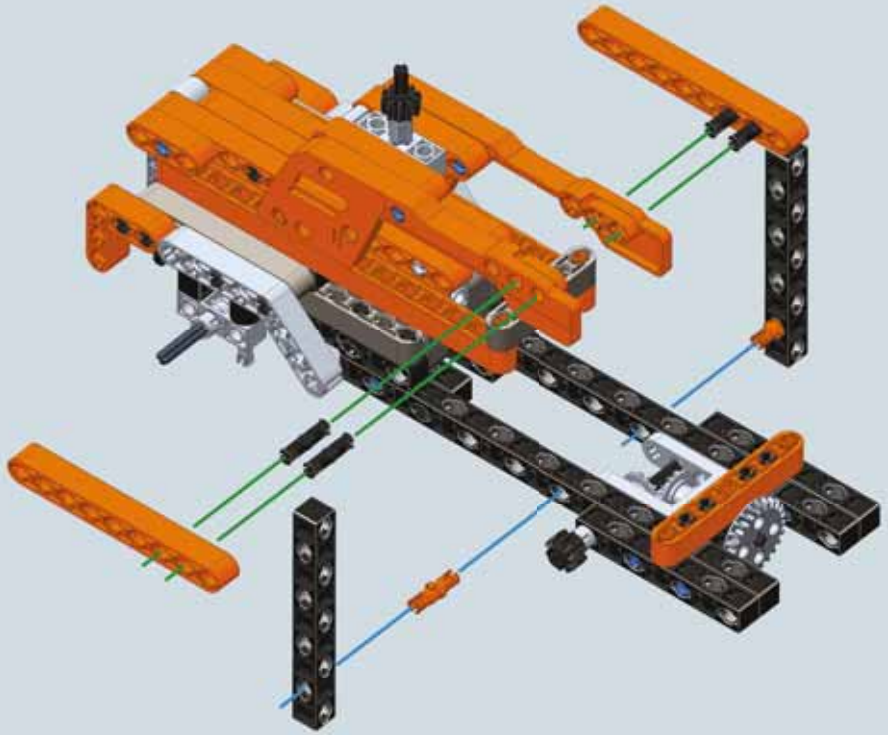

21

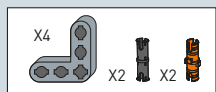
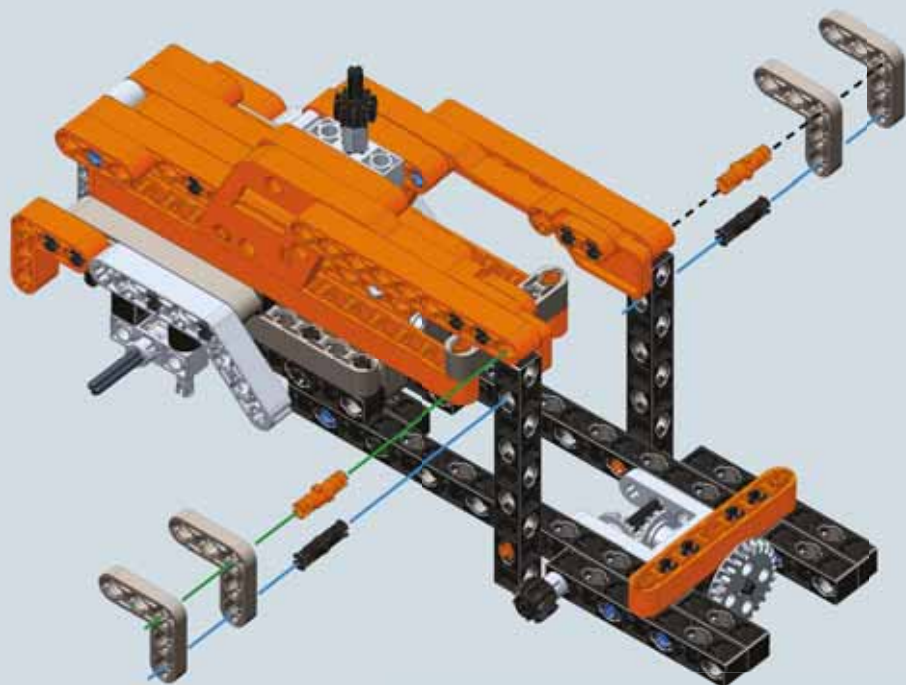

22

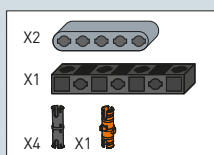
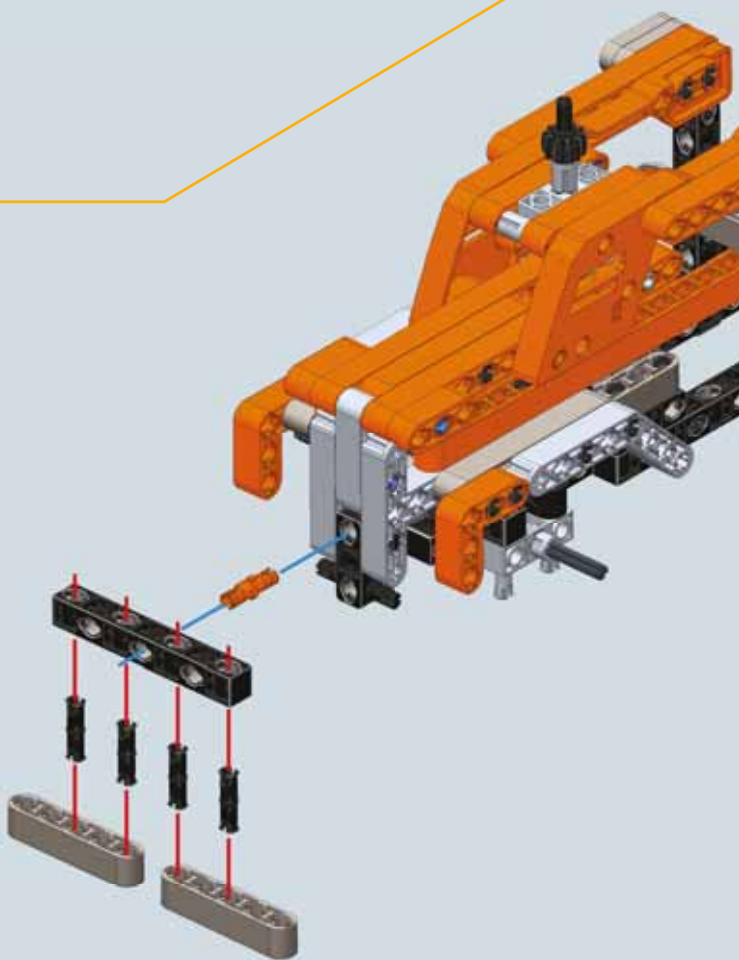

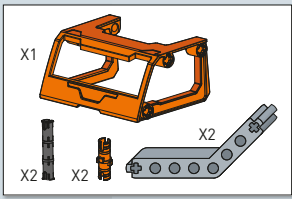

23

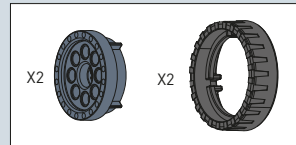
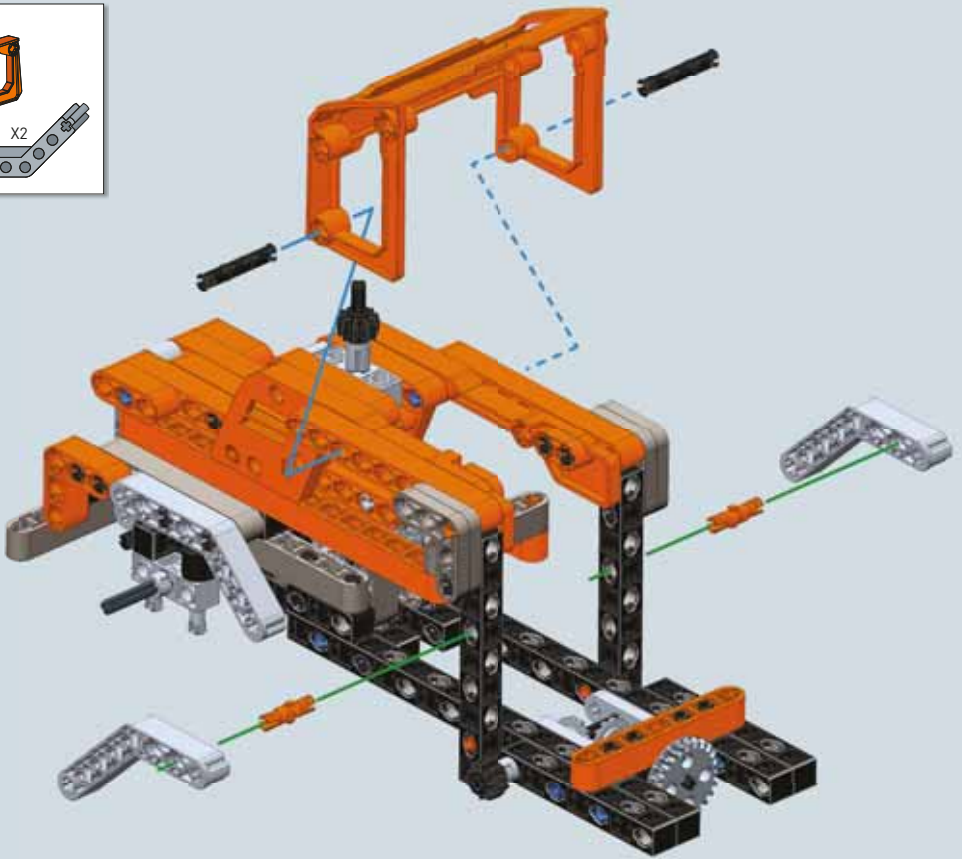

24

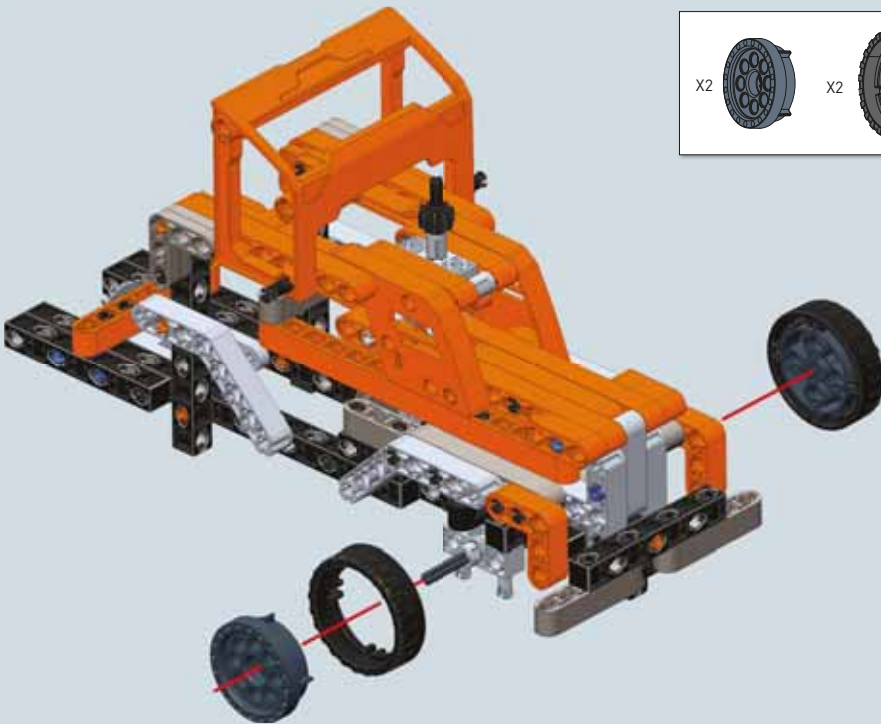

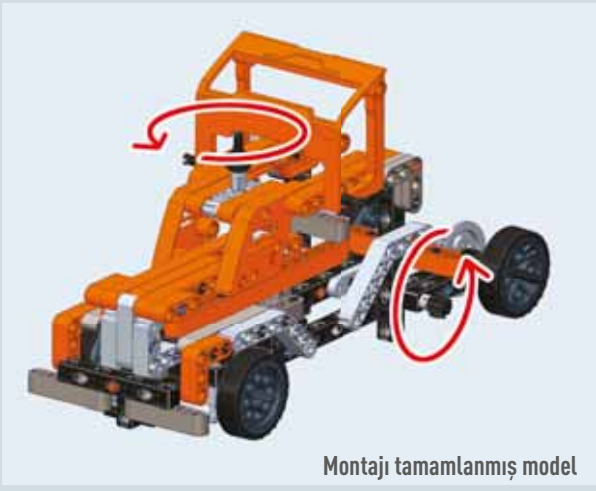
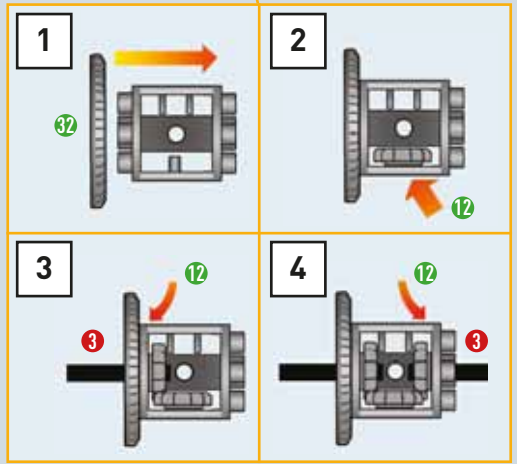
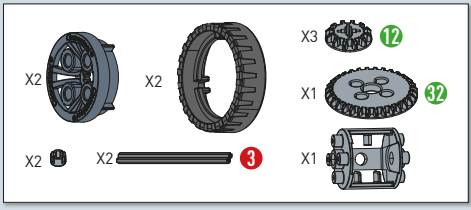
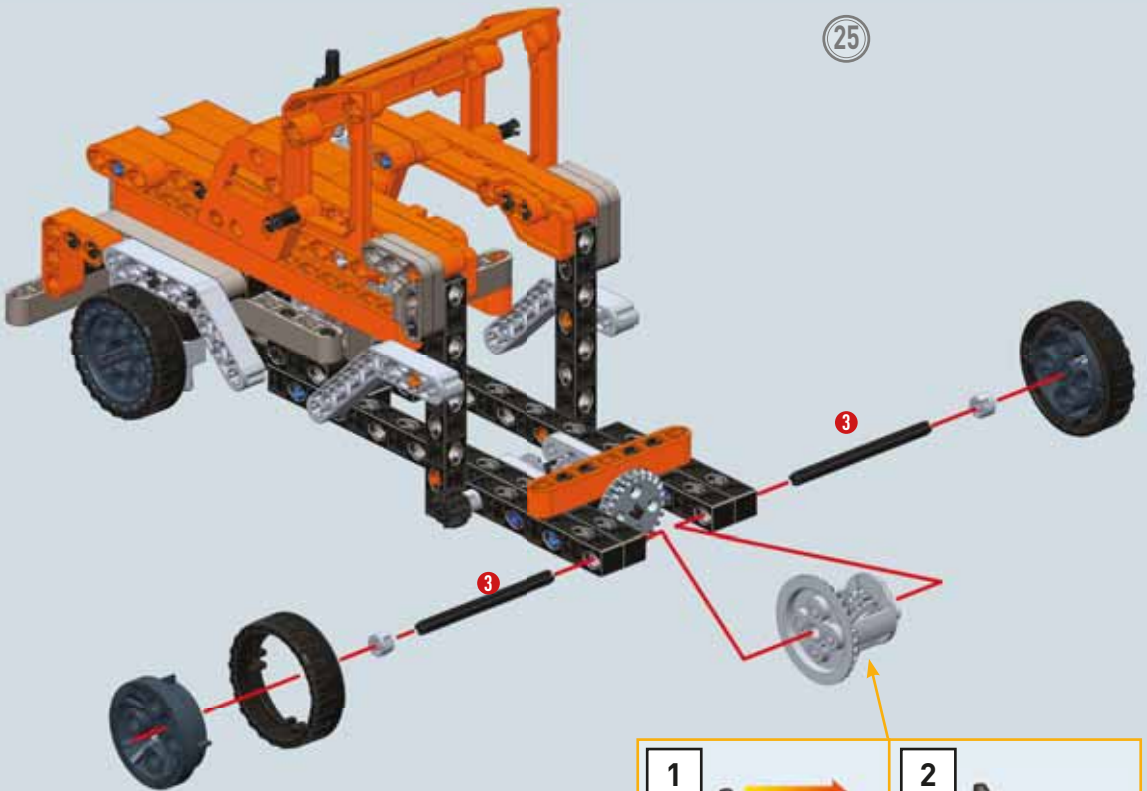

Montajı tamamlanmış model

