

# MECHANICA

## Laboratorium

### LANDBOUWMACHINES

#### Constructies 1 - 6

- 1 - Tractor met een "gloeikopmotor"
- 2 - Tractor
- 3 - Landbouwwerktuigen: zwadkeerder
- 4 - Landbouwwerktuigen: sproeimachine
- 5 - Druivenoogstmachine
- 6 - Tomatenoogstmachine



Leverancier: Clementoni S.p.A.  
Zona Industriale Fontenoce s.n.c.  
62019 Recanati (MC) - Italy  
Tel. +39 071 758111  
[www.clementoni.com](http://www.clementoni.com)

Filiaal: Clementoni Benelux sprl  
Steenweg op Ninove, 1120  
1080 Brussels - Belgium  
Tel. +32 2 527 31 96  
e-mail: [benelux@clementoni.com](mailto:benelux@clementoni.com)

# 1 TRACTOR MET EEN "GLOEIKOPMOTOR"

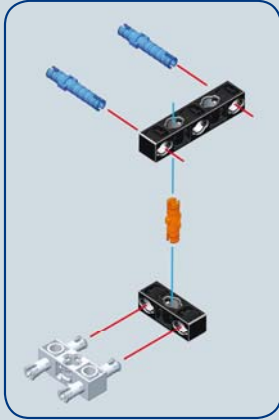

1

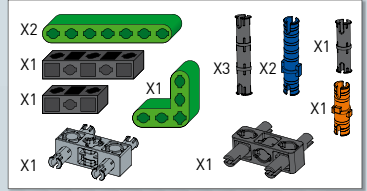

2



## Technische aantekeningen en wetenswaardigheden

De eerste tractoren met een gloei-kopmotor ontstonden aan het einde van de 19e eeuw. Halverwege de 20e eeuw werden ze wijd-verspreid gebruikt. Voordat de motor gestart kon worden moest het voorste deel van de tractor (de gloei-kop) met een aardolielamp of een gasbrander opgewarmd worden tot een temperatuur van 400-700 °C. Vervolgens kon de motor gestart worden met een krachtige duw tegen het grote schijf (het vlieg-wiel) aan de voorkant.

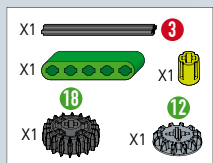
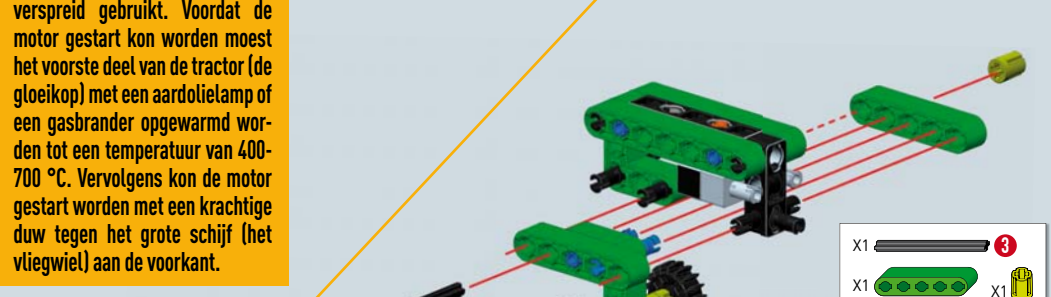
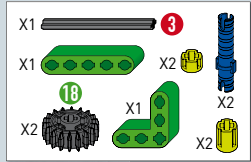
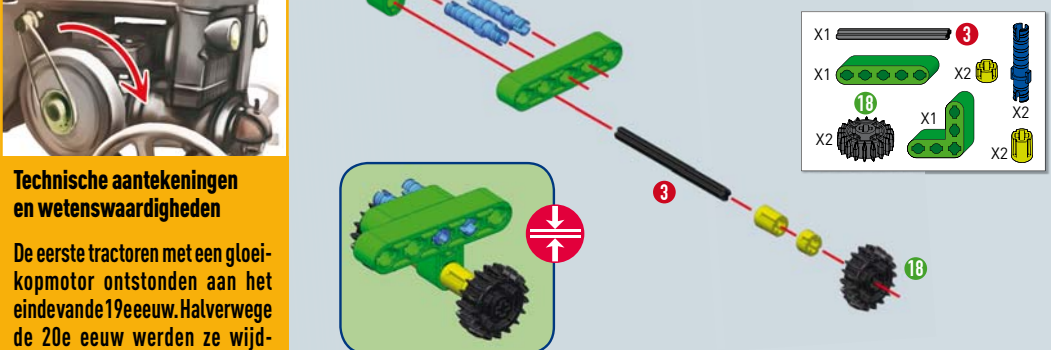

3



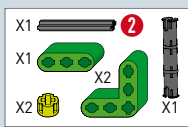

4

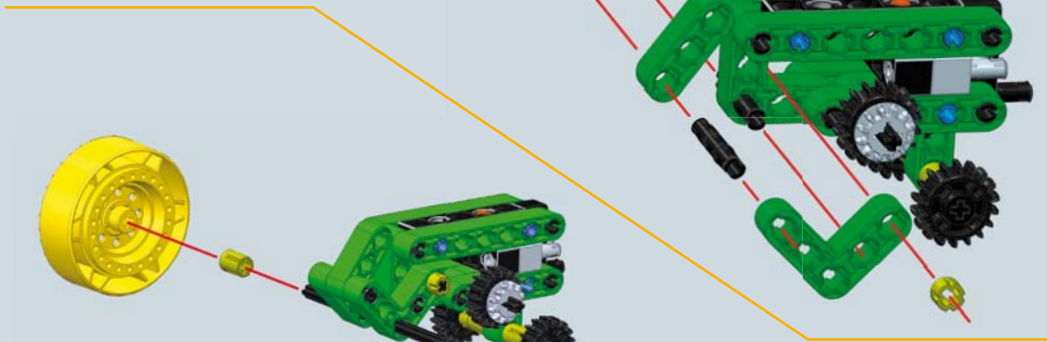

Uiteindelijk model



4

5



## 2 TRACTOR

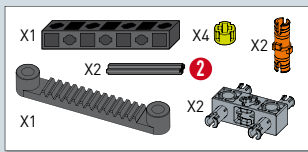

1

**Technische aantekeningen en wetenswaardigheden**

Een tractor is een landbouwmachine die vermogen kan ontwikkelen voor het slijpen of aandrijven van de landbouwwerktuigen die erop zijn aangesloten.

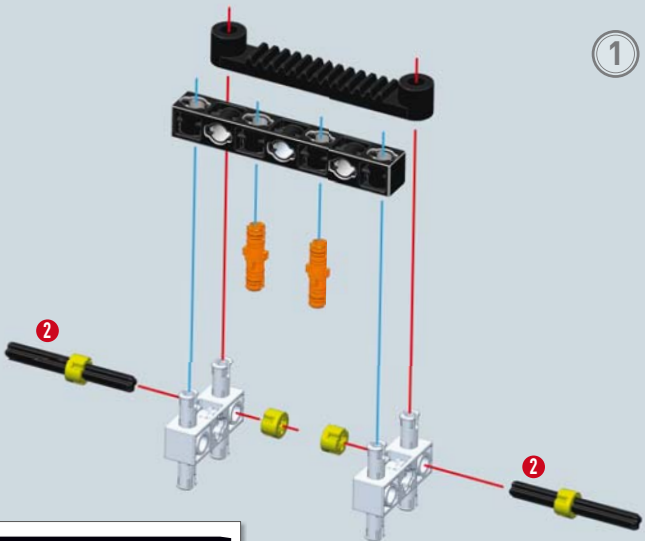

2

- X2
- X1
- X1

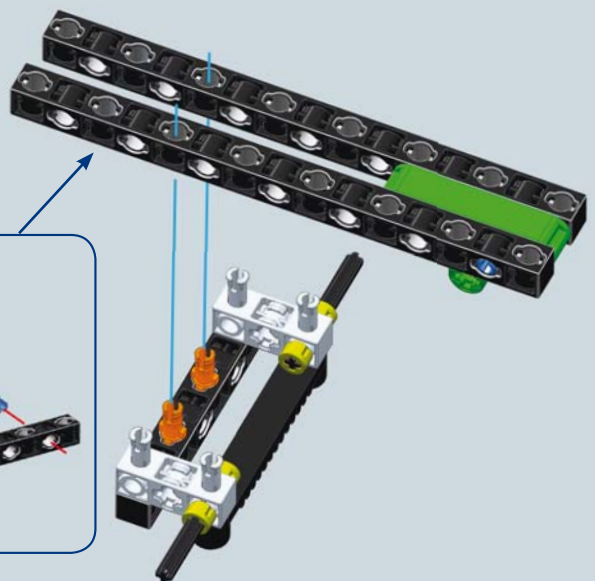
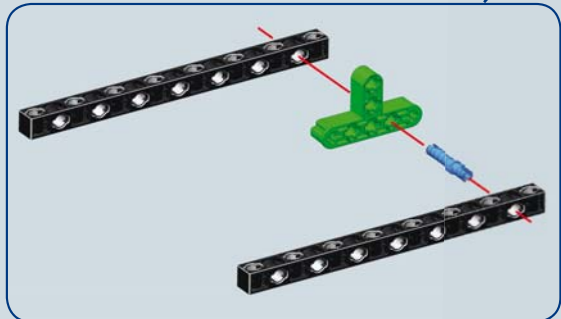

3

- X1
- X1
- X1
- X1
- X2
- X2
- X2
- X2
- X2

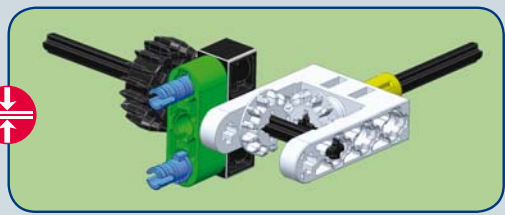
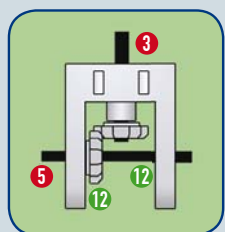
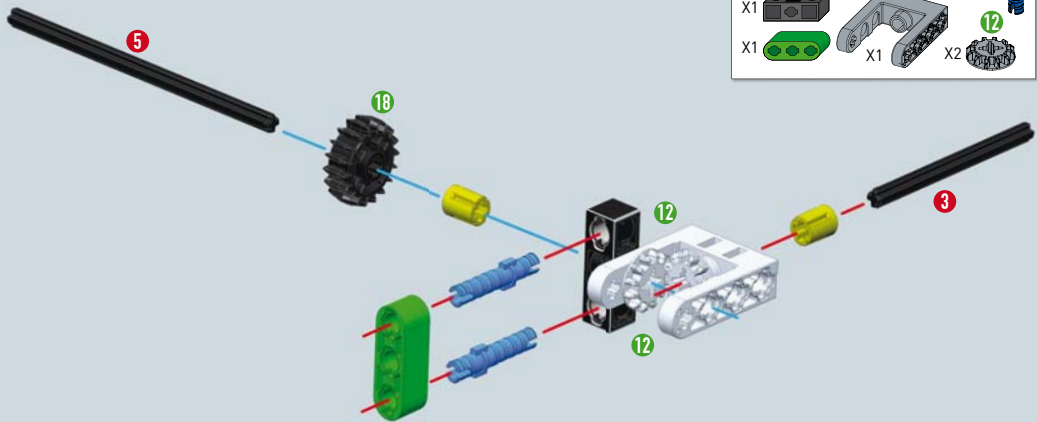



4

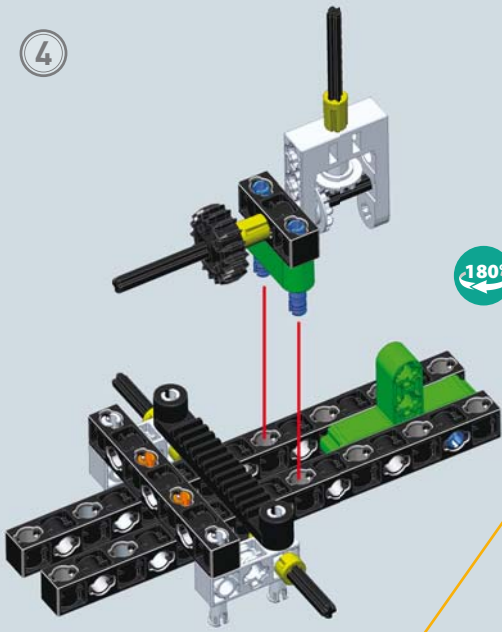

180°

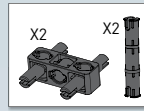

5

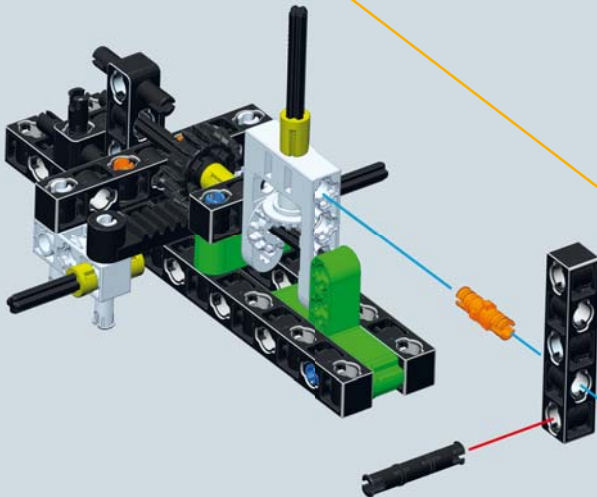
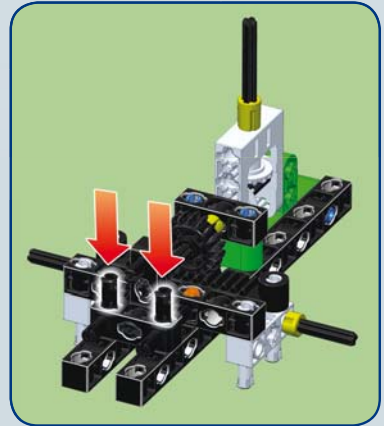
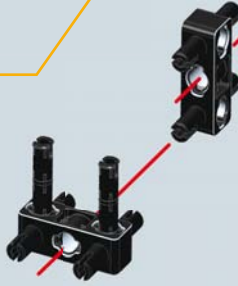
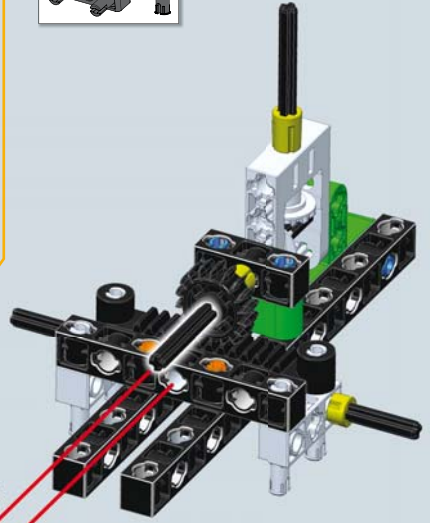

6

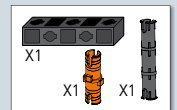

7

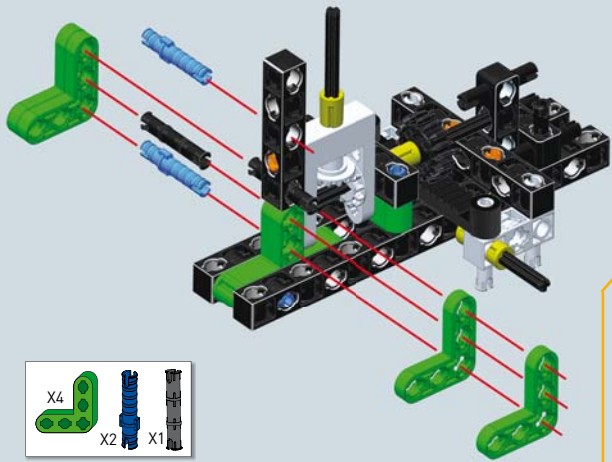

- X4
- X2
- X1

8

- X1
- X1



9

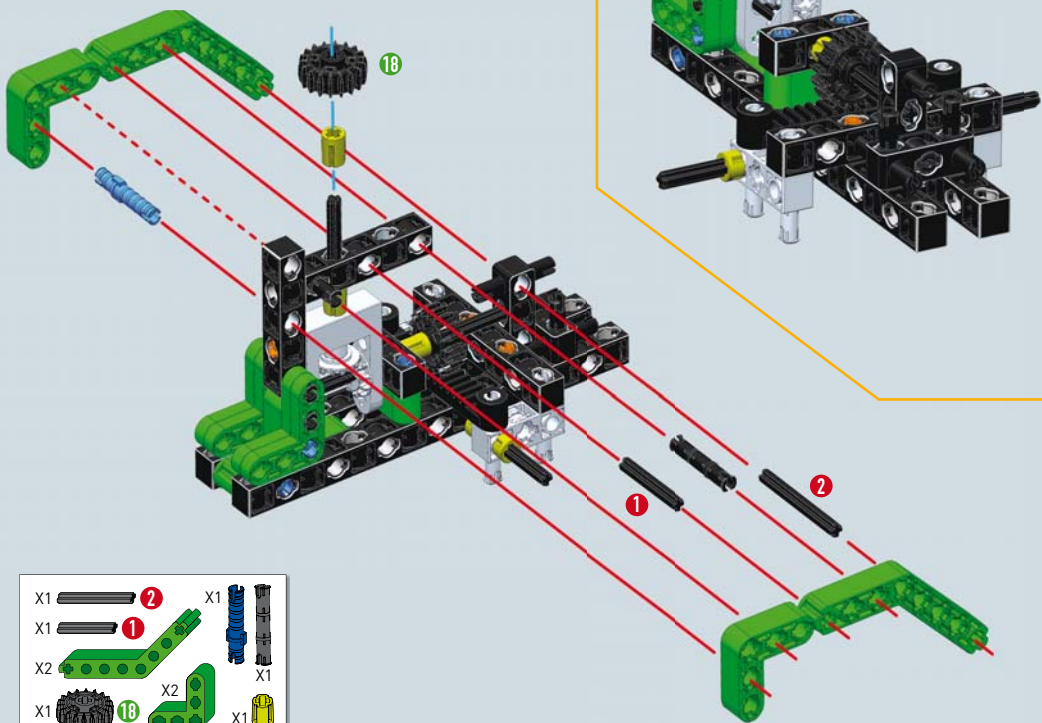

- X2
- X1
- X1
- X1
- X2
- X1
- X1
- X2



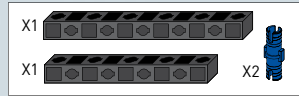
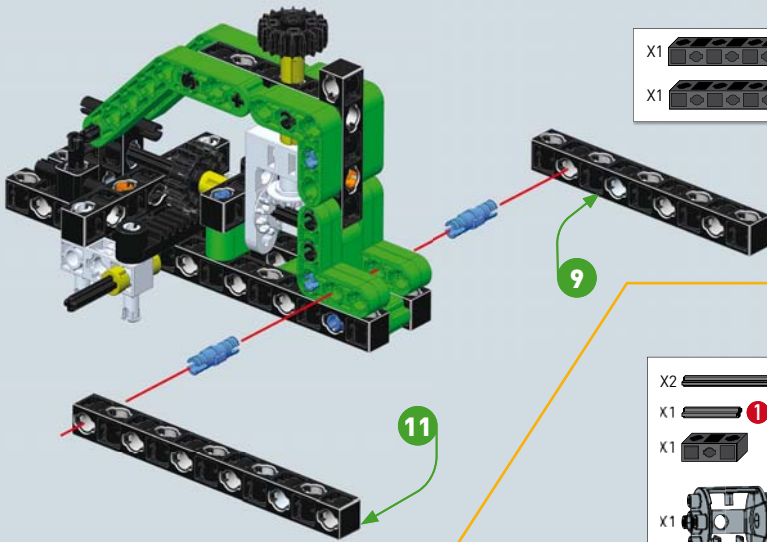

10

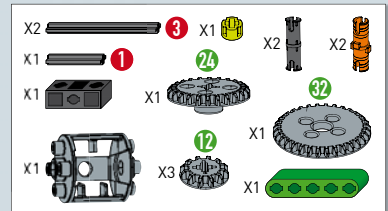

11

### Technische aantekeningen en wetenswaardigheden

De beweging kan aan de landbouwwerktuigen worden overgedragen door de aftakas aan de achterkant: de motor laat de aandrijfwielen van de tractor draaien met het differentieel. Men kan er echter ook voor kiezen om het vermogen van de motor over te dragen naar de aftakas met een systeem van tandwielen en tandwieloverbrengingen die direct op de motor zijn aangesloten.

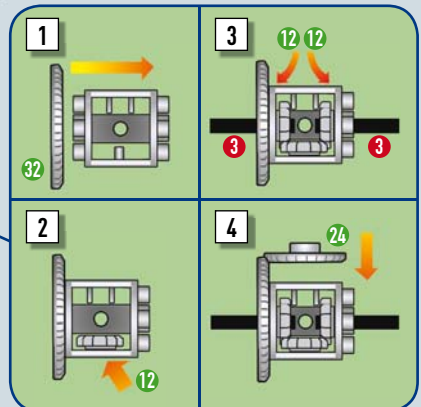
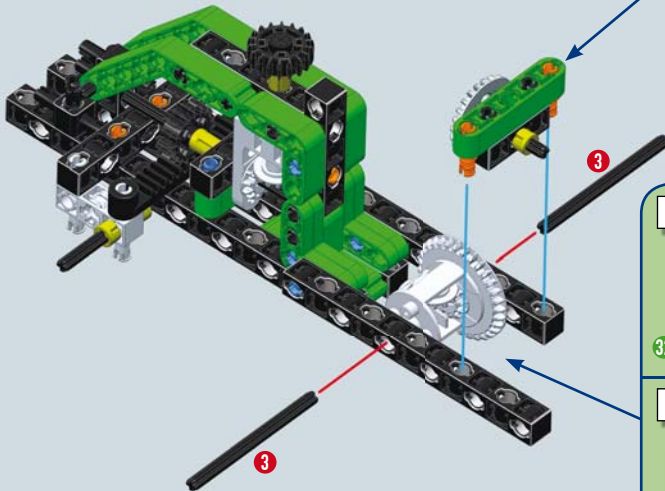
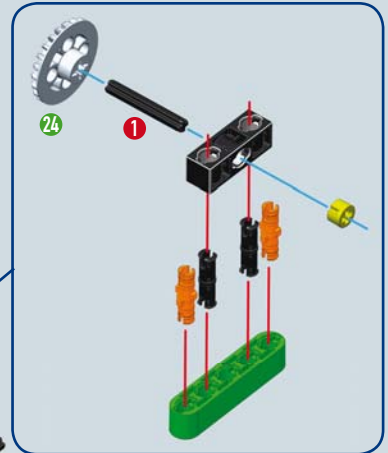
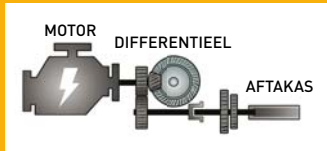

12

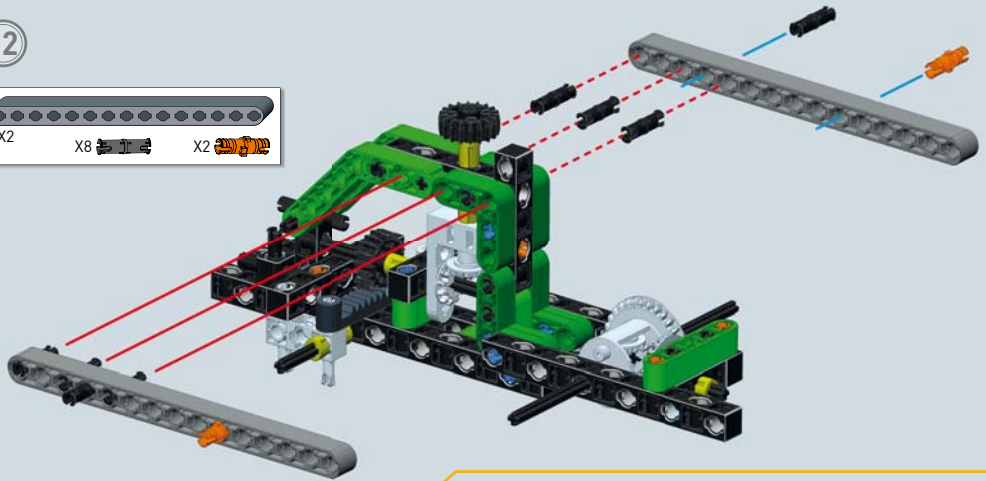
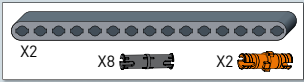

13

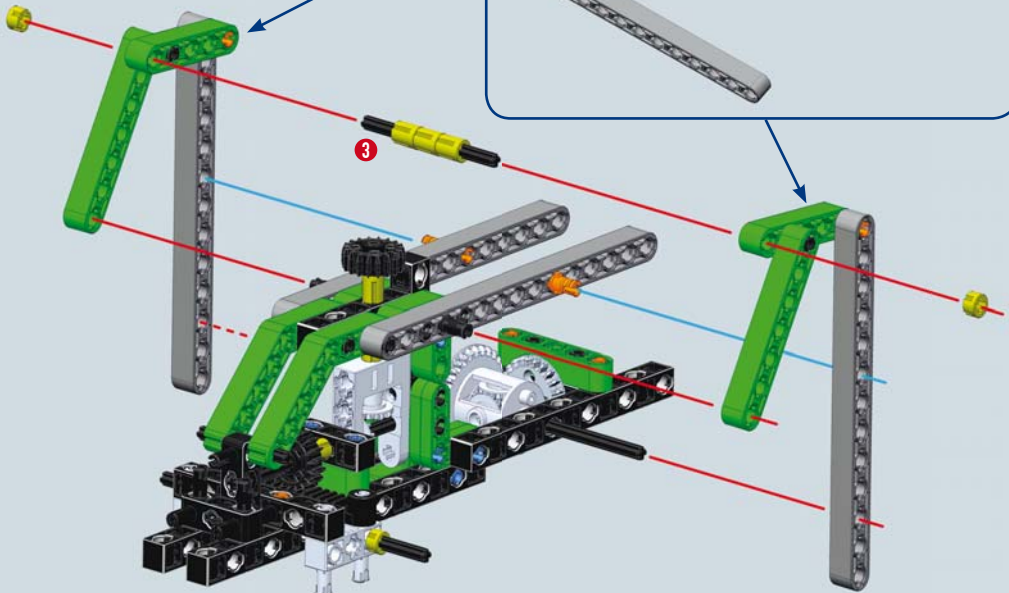
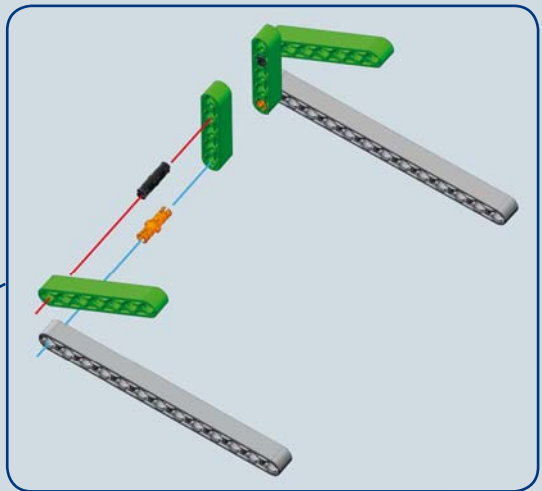
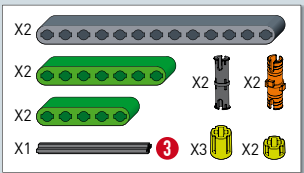



14

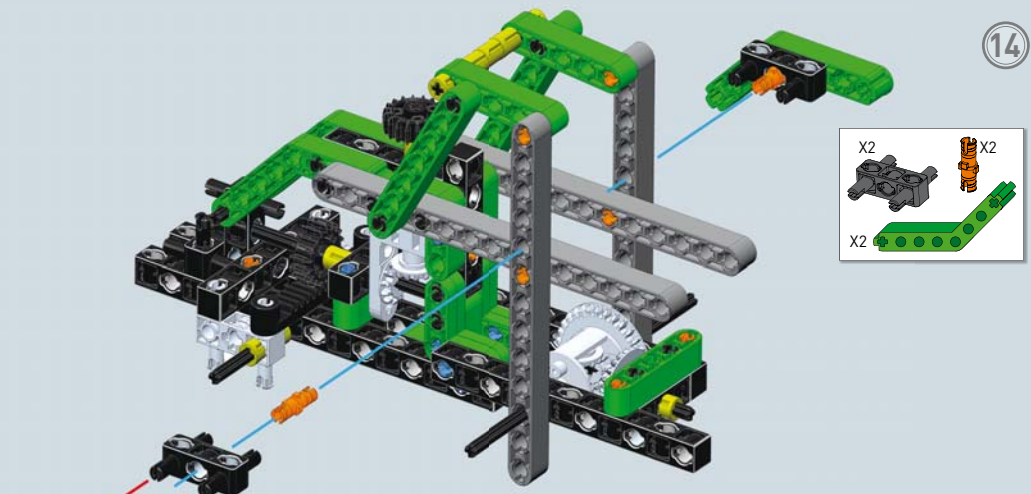

- X2
- X2
- X2

15

- X1
- X2
- X1
- X1

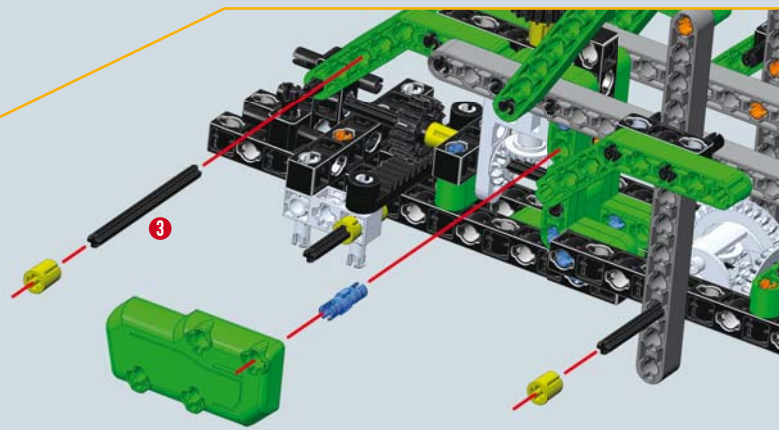

16

- X2
- X1
- X1

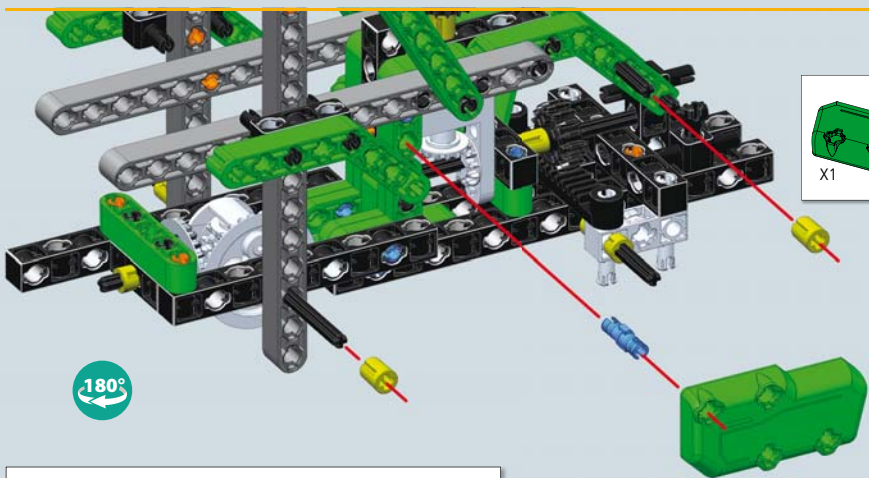

180°



16

180°

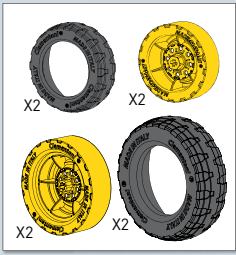
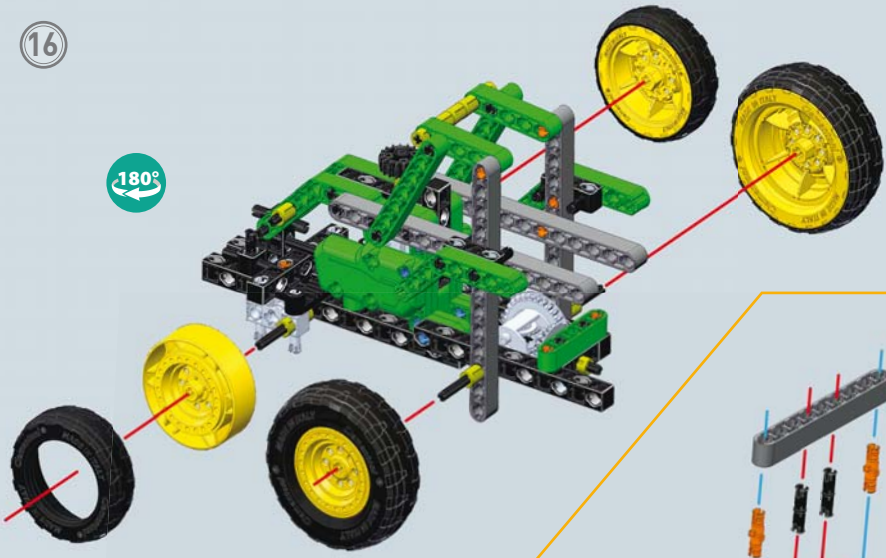

17

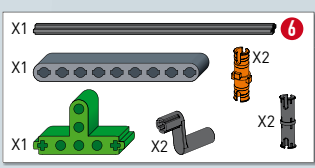

Uiteindelijk model

1:1

6

## Technisch-wetenschappelijke informatie

Het differentieel is een mechanisch onderdeel dat het vermogen van de motor kan overdragen naar de twee aandrijfwielen.



- 1 - Pignon: draagt het vermogen over van de motor naar het ringwiel en vervolgens naar de aandrijfwielen.
- 2 - Ringwiel: verbonden aan de satellietdrager en is stevig gekoppeld aan de pignon.
- 3 - Satellietdrager: hier zijn alle tandwielen in aangebracht.
- 4 - Satellietwielen: tandwielen die aan de houder zijn bevestigd.
- 5 - Planeetwielen: tandwielen die aan de aandrijfassen zijn bevestigd.
- 6 - Aandrijfassen: assen die de aandrijfwielen met de planeetwielen verbinden.

Het differentieel is ontworpen om ervoor te zorgen dat de twee wielen in een bocht op verschillende snelheid kunnen draaien: op een onrecht stuk weg legt het wiel in de buitenbocht meer afstand af dan het wiel in de binnenbocht. Daarom moet het wiel in de buitenbocht sneller draaien.



De pignon draagt het vermogen van de motor over naar het differentieel en dus naar de aandrijfassen.

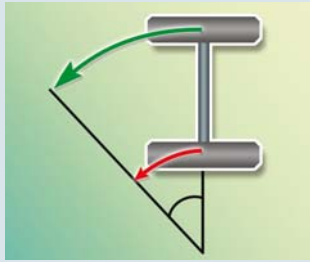

In een bocht legt het wiel in de binnenbocht minder afstand af dan het wiel in de buitenbocht.



Dankzij het differentieel kunnen de wielen van een voertuig in een bocht op verschillende snelheid draaien.

## 3 LANDBOUWERKTOUIGEN: ZWADKEERDER

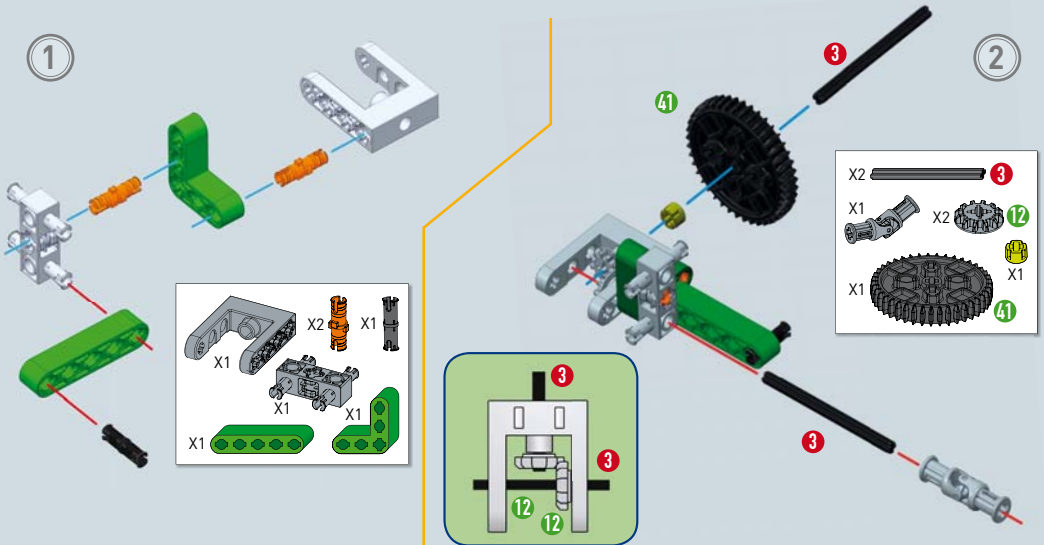

1:1 

Volg de aanwijzingen op het geïllustreerde blad met waarschuwingen voor de montage van de cardankoppeling.

3

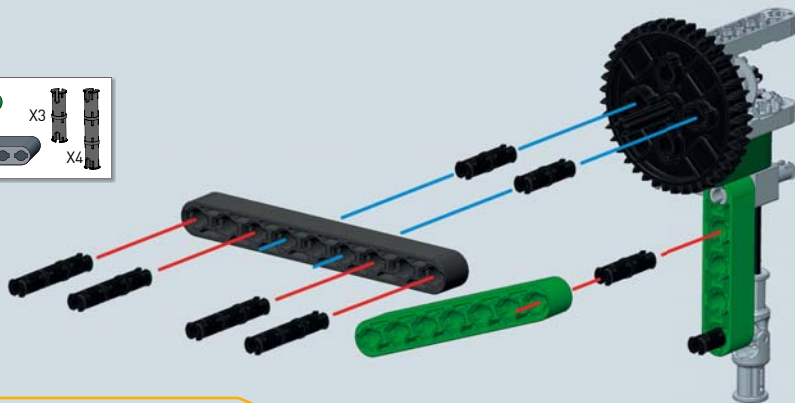
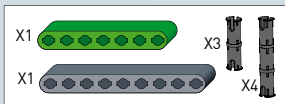



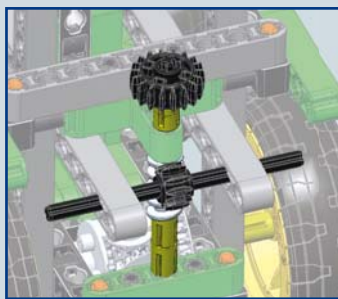
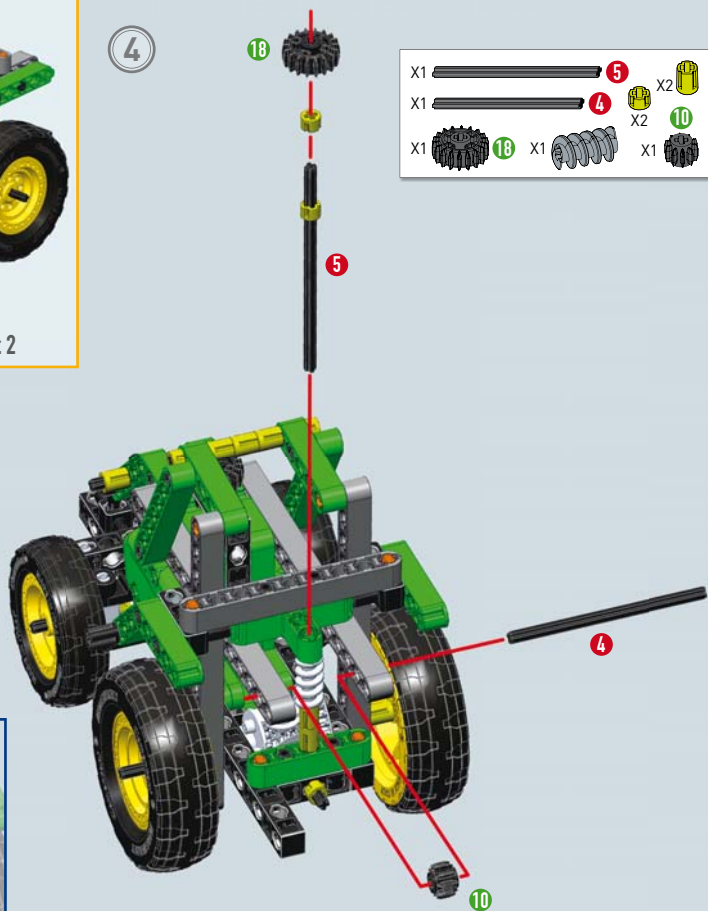
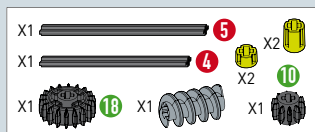

4





5

X1  4   
 X2  12 X2  X2

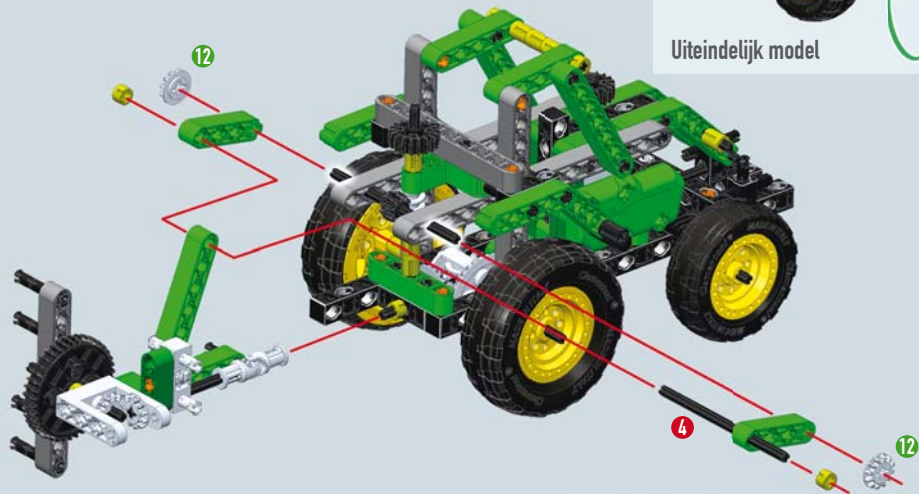

## 4 LANDBOUWWERKTUIGEN: SPROEIMACHINE



X1  5  
 X1  18 X1  10

1

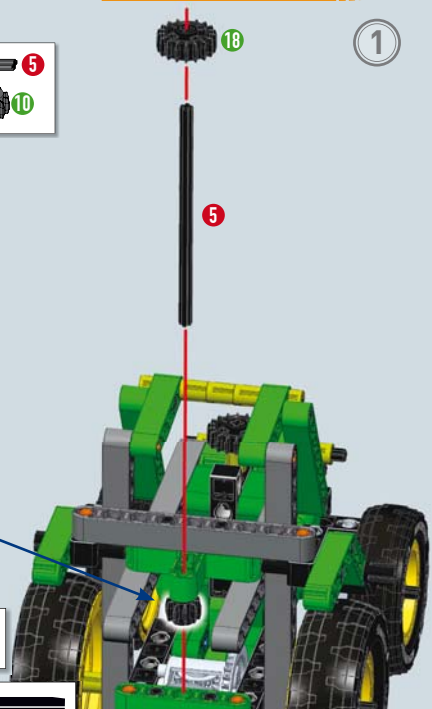

2

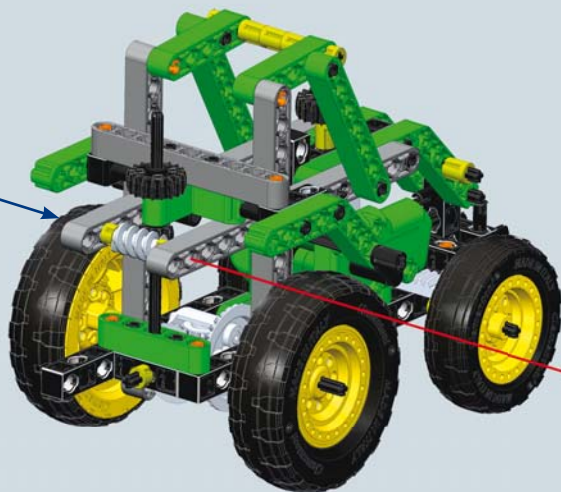

- X1 3 X2
- X1 18 X1



3

- X1 3
- X1 18 X1
- X1

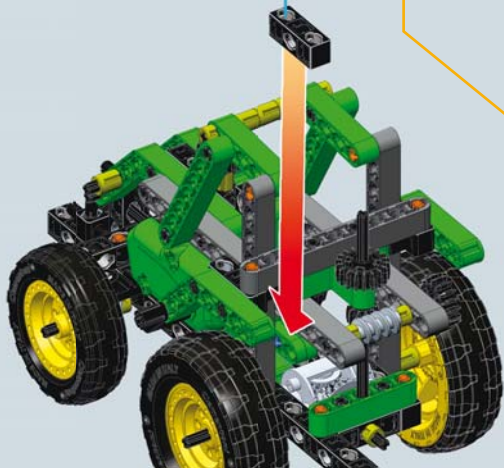
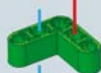
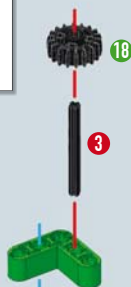

4

- X2
- X1
- X2
- X2

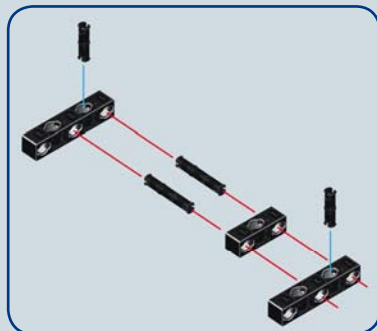

1:1 3

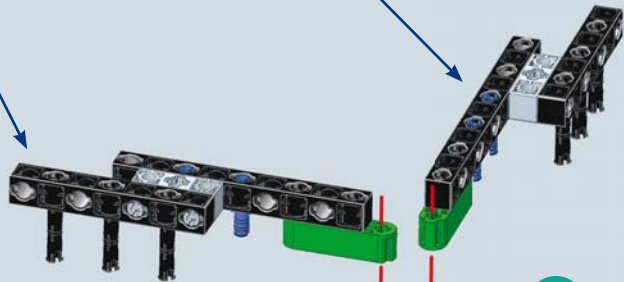
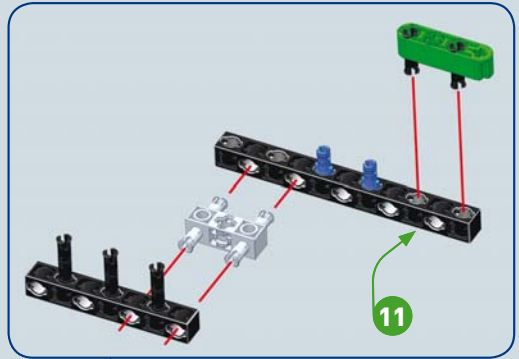
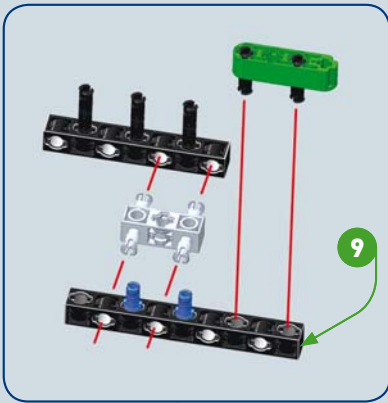

- |    |  |    |  |  |
|----|--|----|--|--|
| X2 |  | X2 |  |  |
| X2 |  |    |  |  |
| X1 |  | X4 |  |  |
| X1 |  | X4 |  |  |



Uiteindelijk model

1

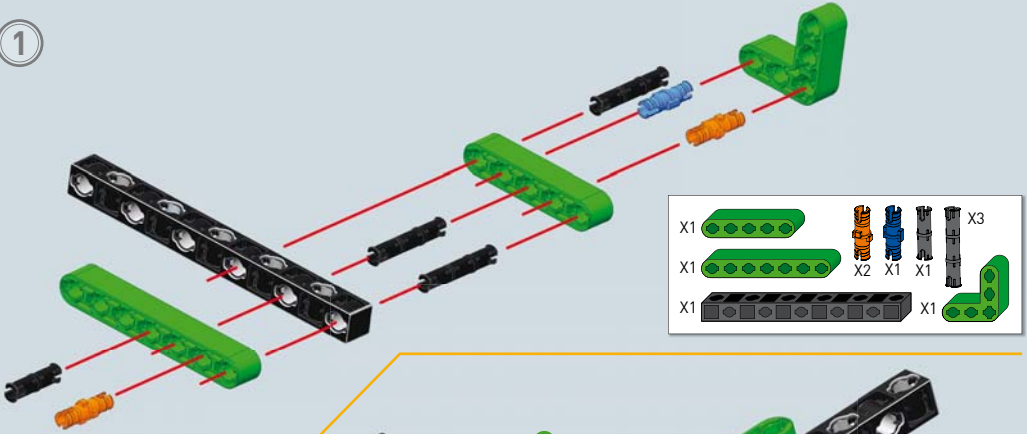

2

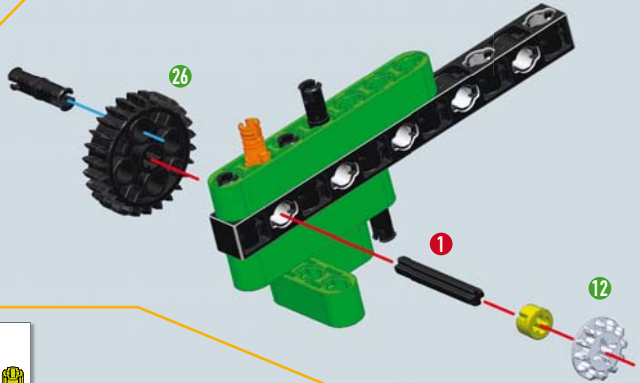
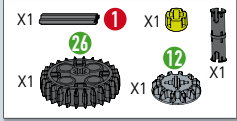

3

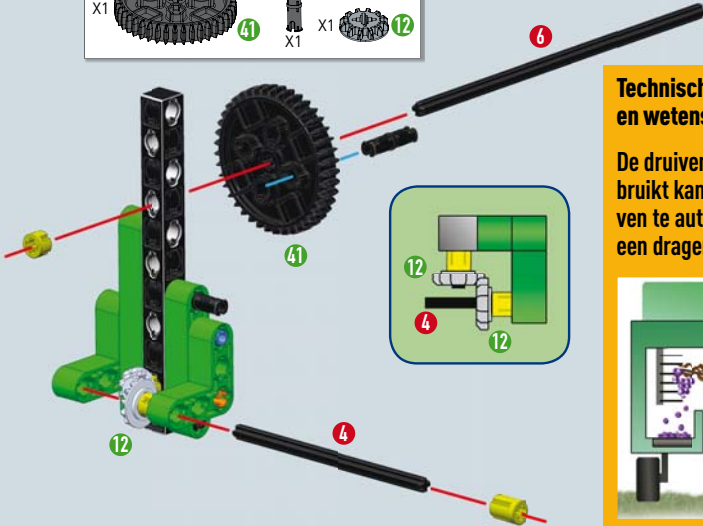
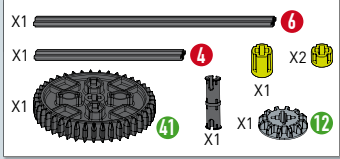

## Technische aantekeningen en wetenswaardigheden

De druivenoogstmachine is een machine die gebruikt kan worden om het oogsten van wijndruiven te automatiseren. Deze machine bestaat uit een dragend chassis dat over de in rechte lijnen geplante wijnranken kan rijden.



Door de schommelende beweging van de trommels in de machine kunnen de druiven geplukt worden.

1:1

1

1:1

4

1:1

6



4

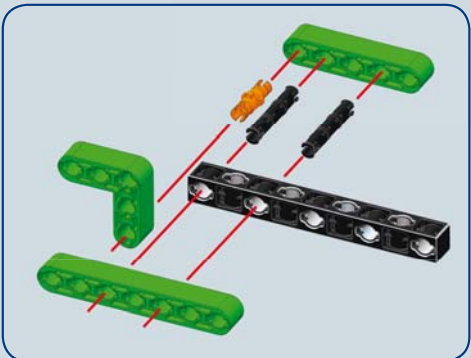
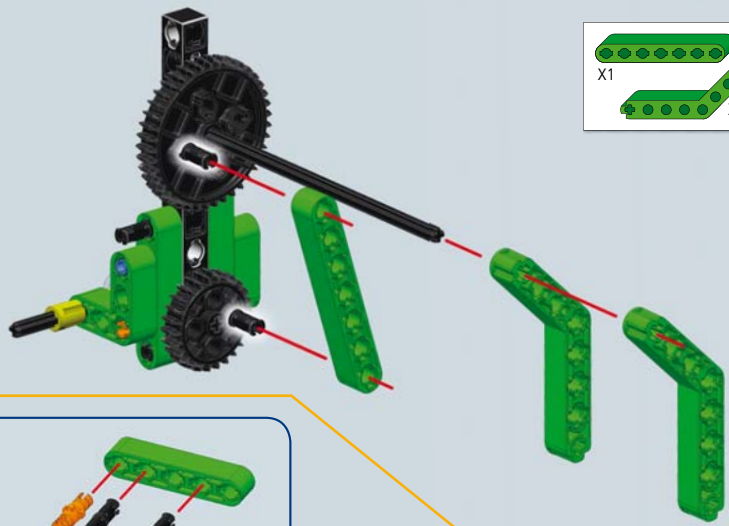
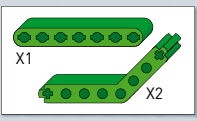

5

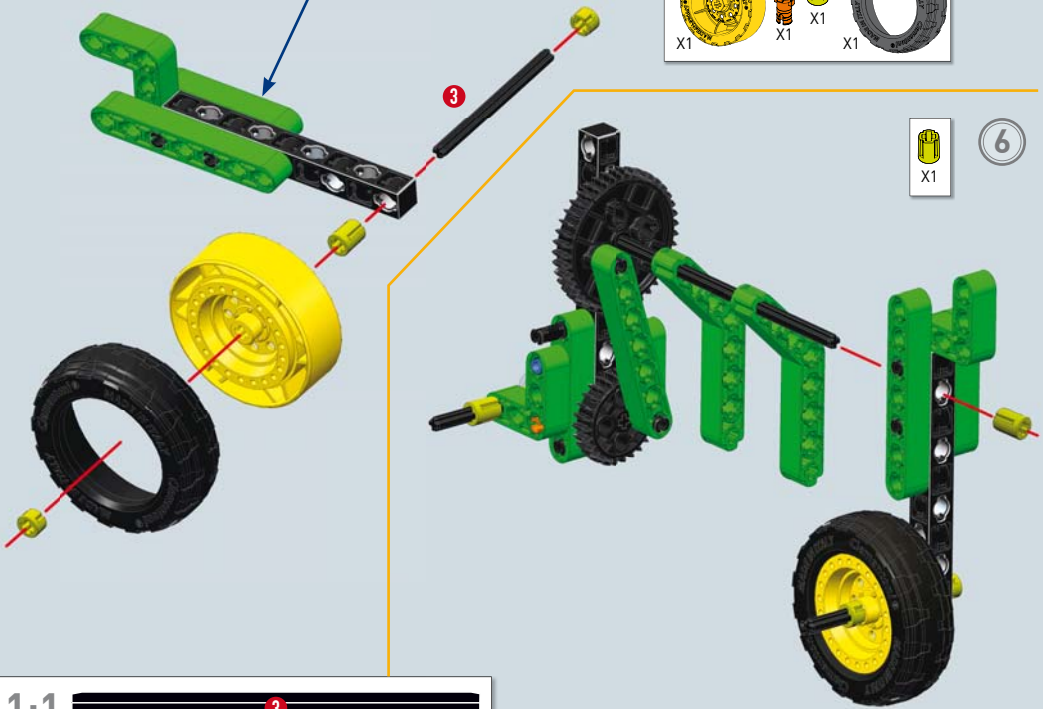
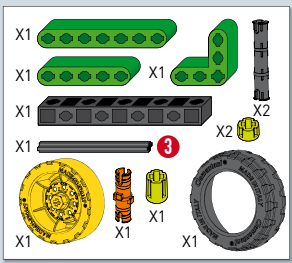

6



7

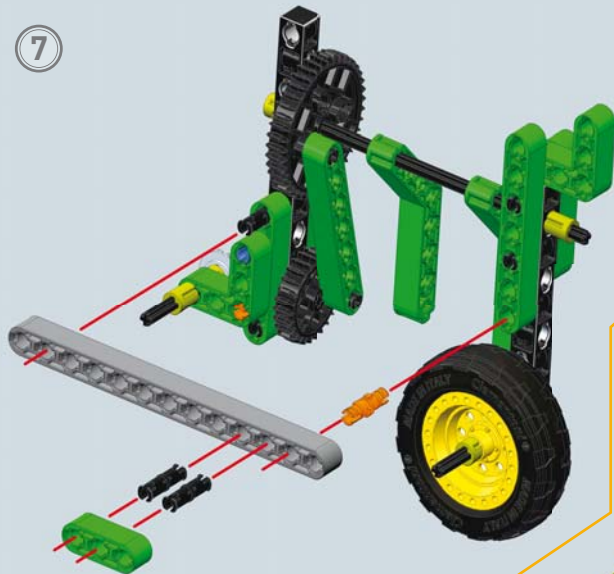

- X1
- X1
- X1
- X2

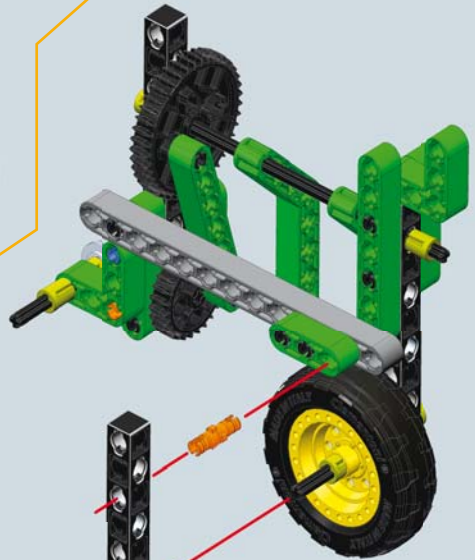

8

- X1
- X1
- X1

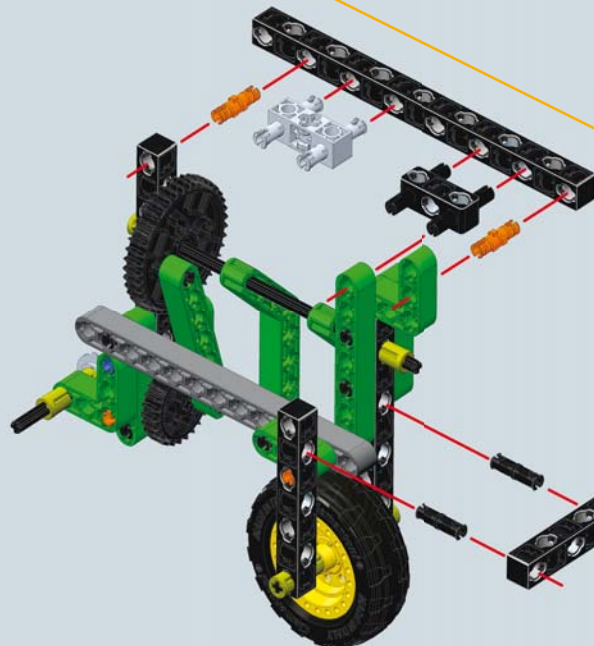

9

- X1
- X1
- X1
- X1
- X2
- X2



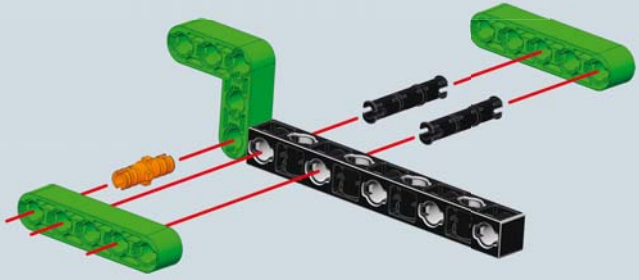
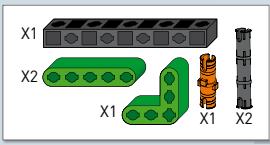
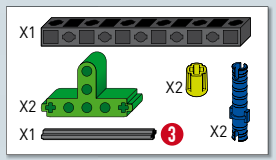
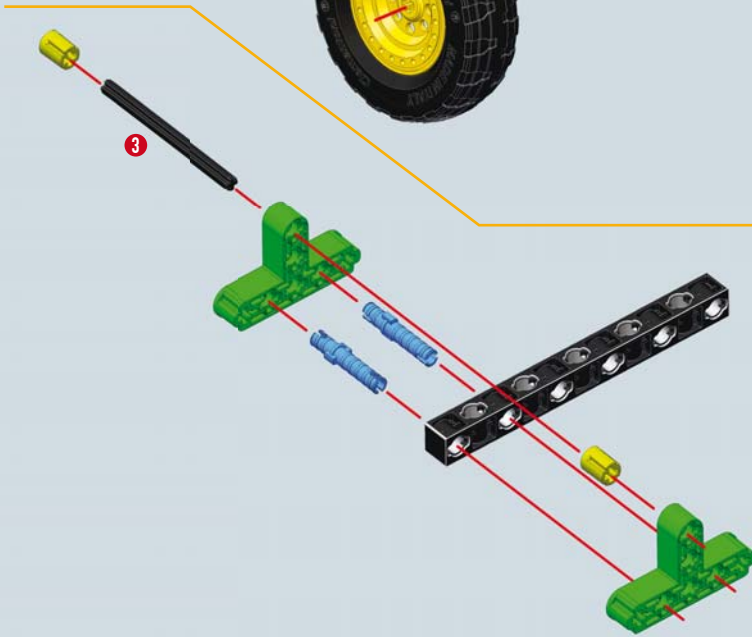
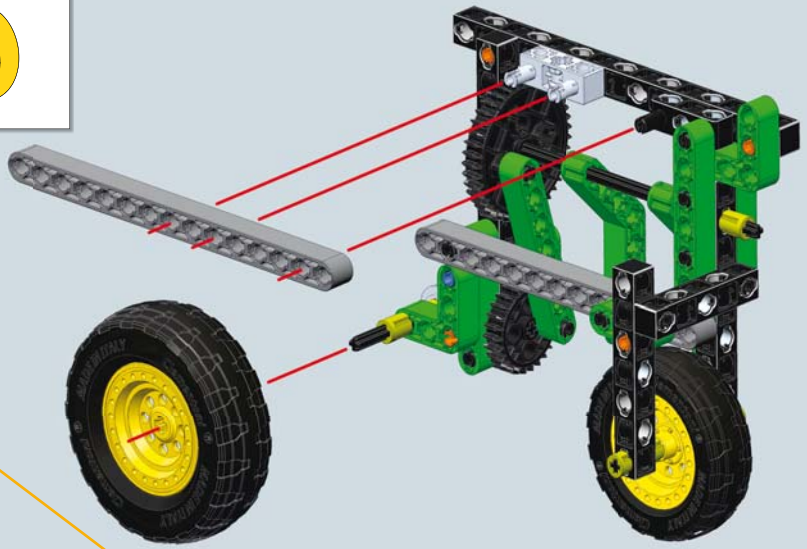
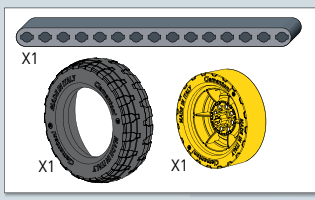

13

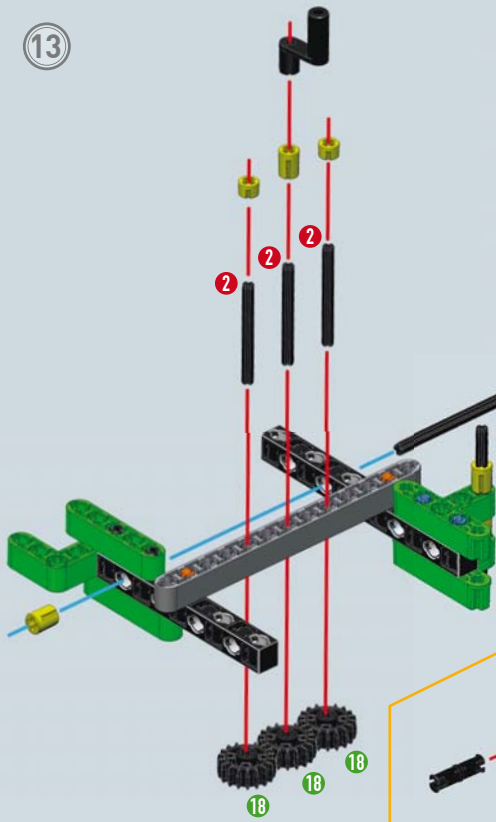

- X1 6
- X3 2
- X3 18
- X1 1
- X3 3
- X2 2
- X2 2
- X1 1

14

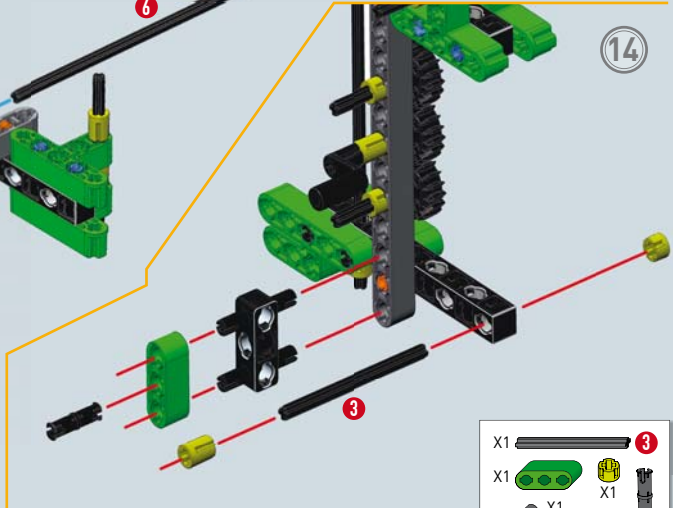

- X1 3
- X1 1
- X1 1
- X1 1
- X1 1
- X1 1

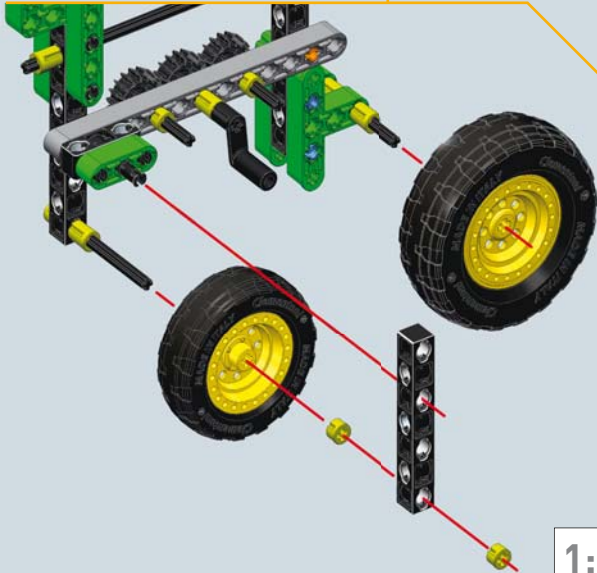

15

- X1 1
- X2 2
- X1 1
- X1 1
- X1 1
- X1 1

1:1 2

1:1 3

1:1 6



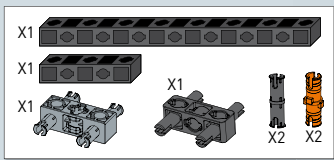

16

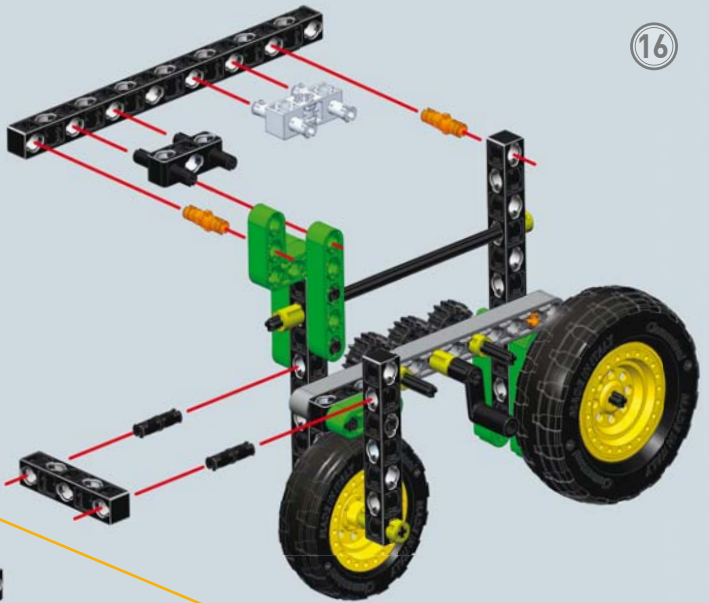

17

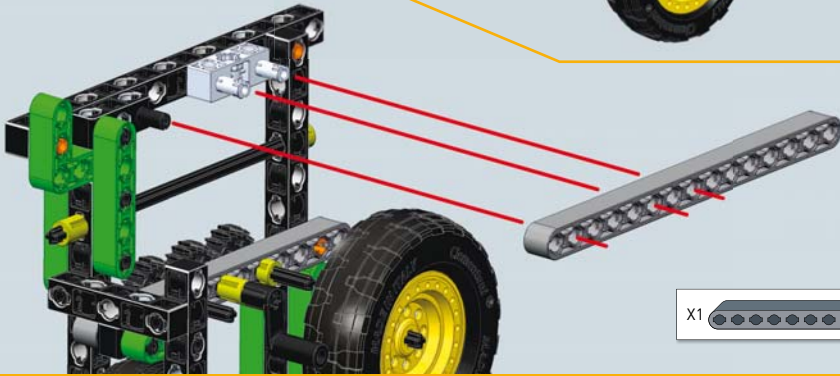

18

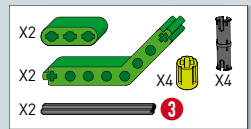
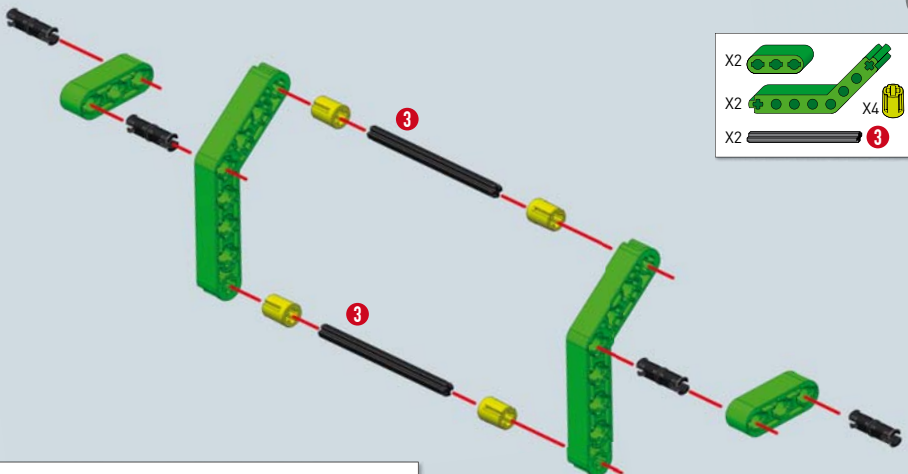

19

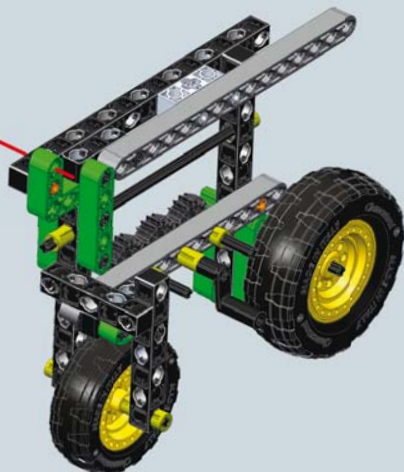
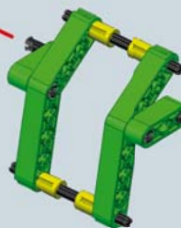
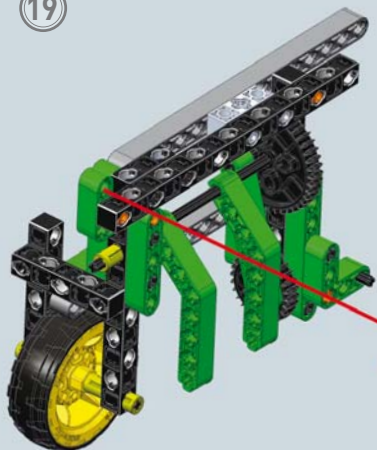

**Technische aantekeningen en wetenswaardigheden**

Op de inwendig schuddende kop zijn schommelde trommels met een rechte of gebogen vorm gemonteerd. Dankzij de mechanische werking van de trommels komen de druiven los en vallen ze op specifieke transportbanden. Deze transportbanden kunnen gebruikt worden om de geogogste druiven schoon te maken en te vervoeren naar de opslagruimte waar ze in speciale houders worden gestort.



20

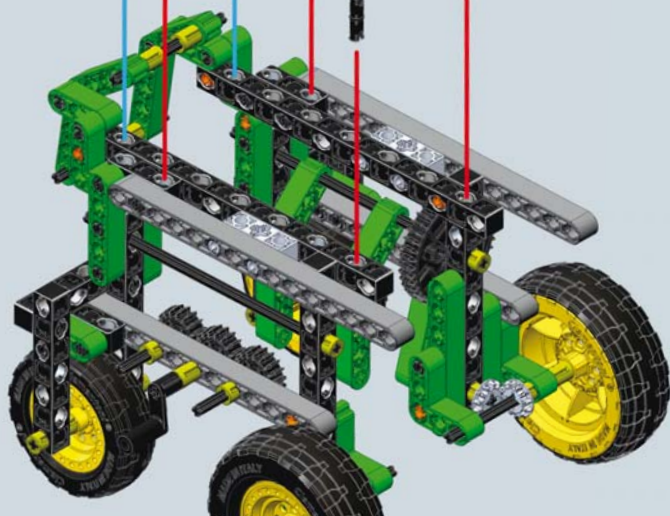
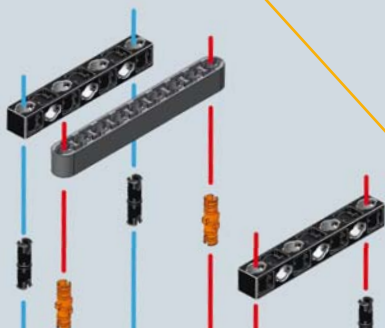

- |    |  |    |    |
|----|--|----|----|
| X1 |  |    |    |
| X2 |  | X4 | X2 |

21

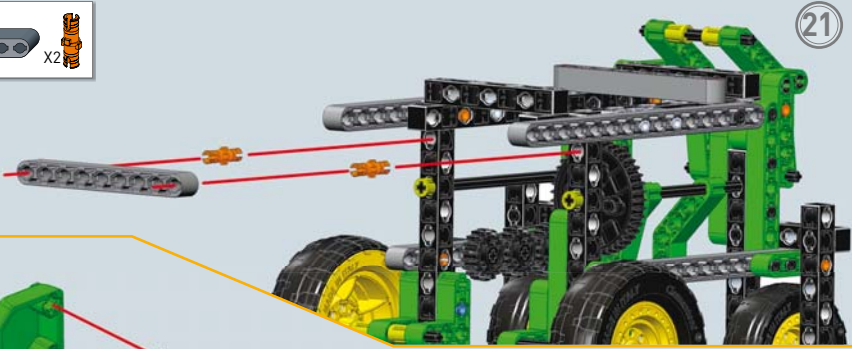

22

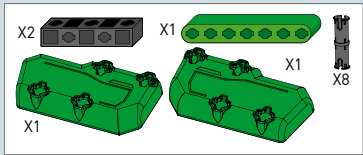
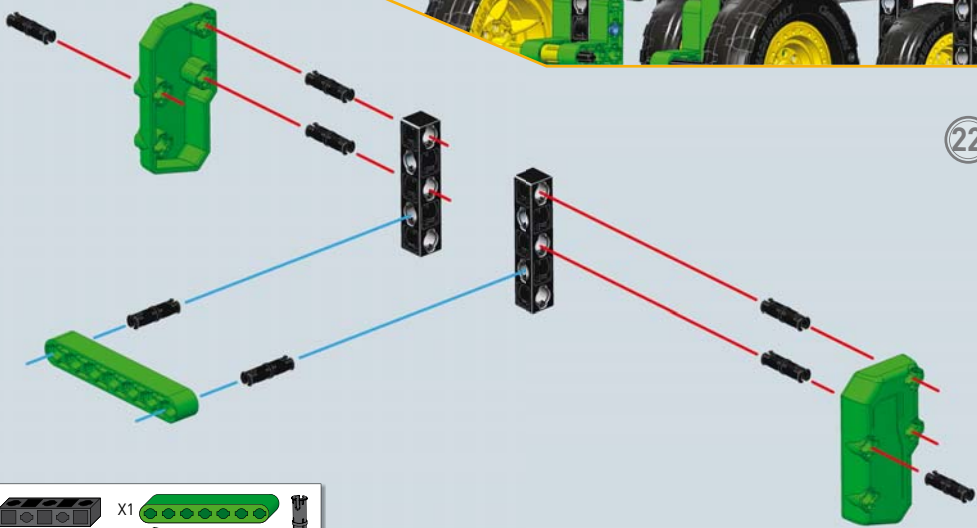

23

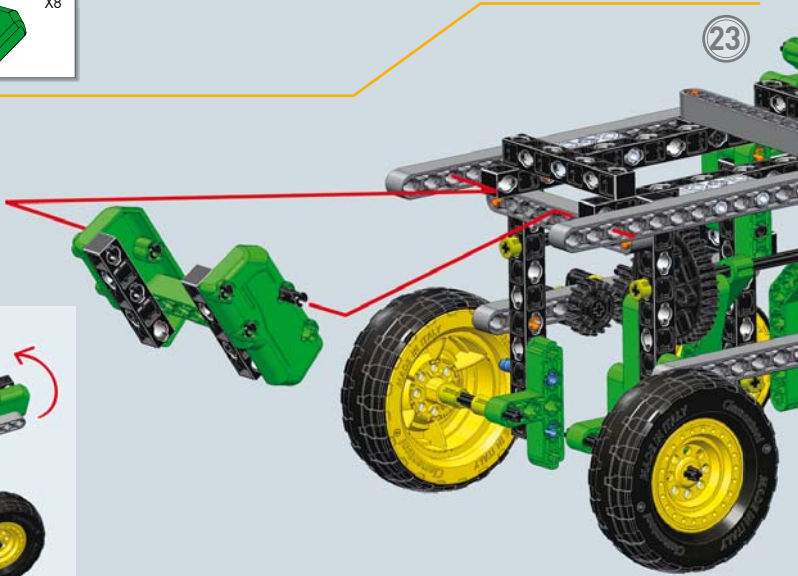

Uiteindelijk model

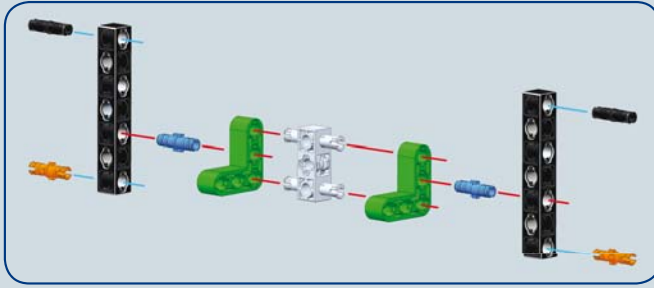

1

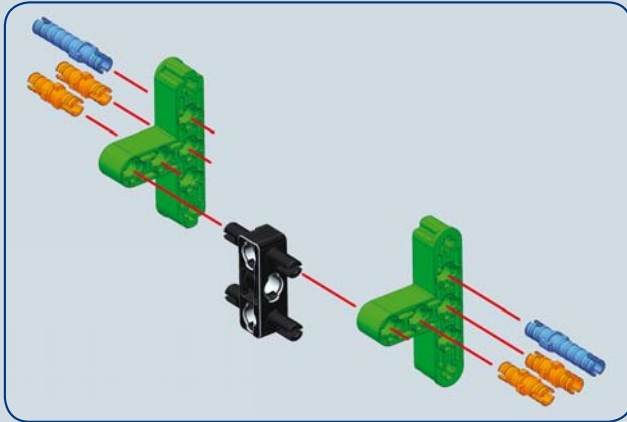
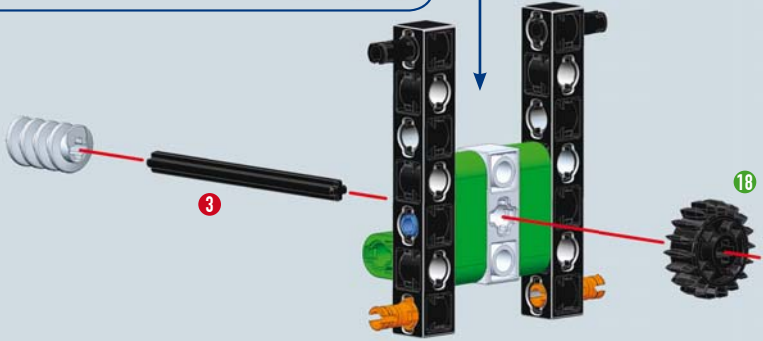
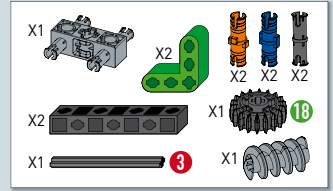

2

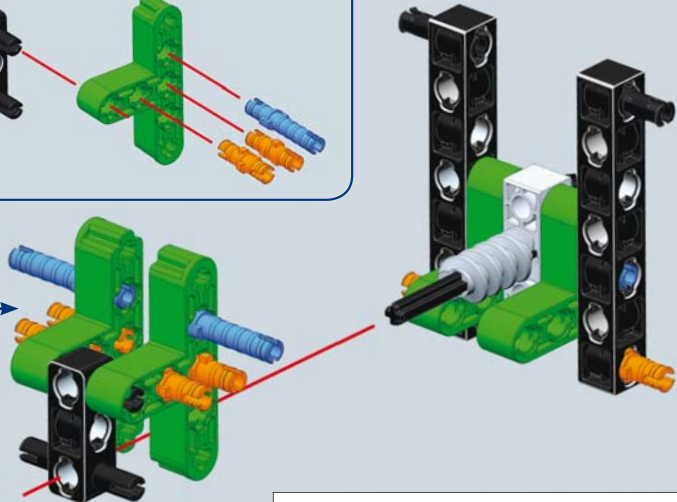
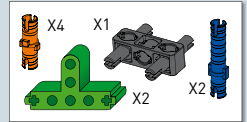



3

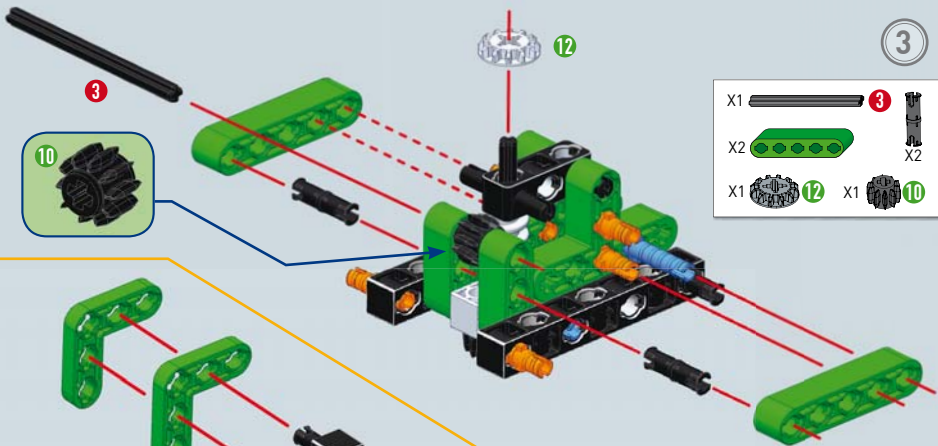

- |    |  |   |    |    |
|----|--|---|----|----|
| X1 |  | 3 |    | X2 |
| X2 |  |   |    |    |
| X1 |  |   | X1 |    |

4

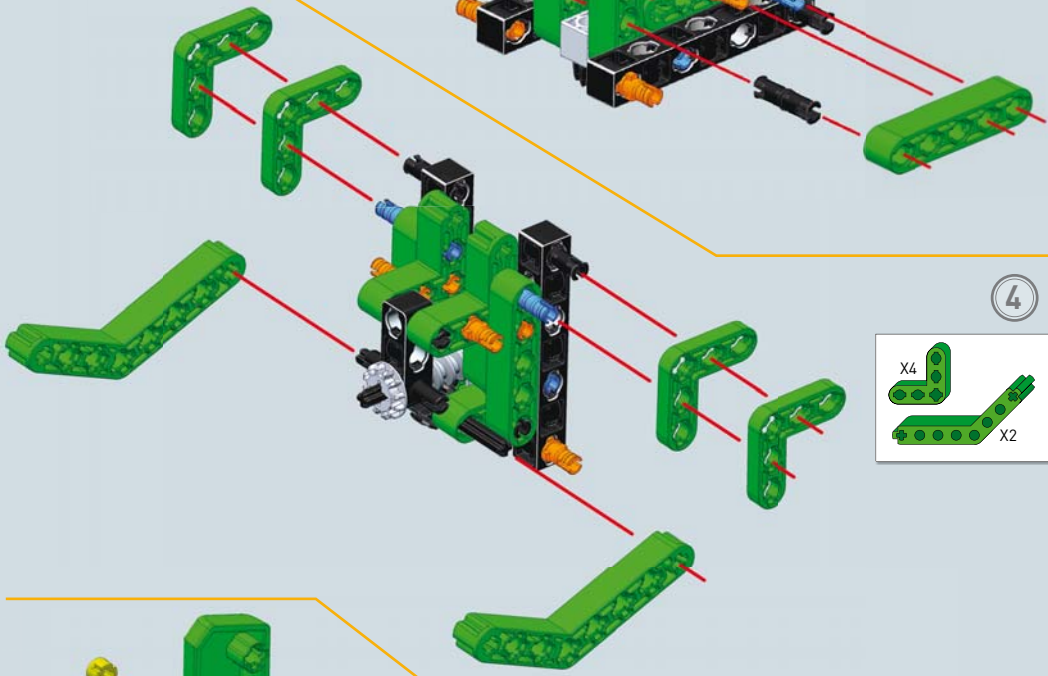

- |    |  |  |  |
|----|--|--|--|
| X4 |  |  |  |
| X2 |  |  |  |

5

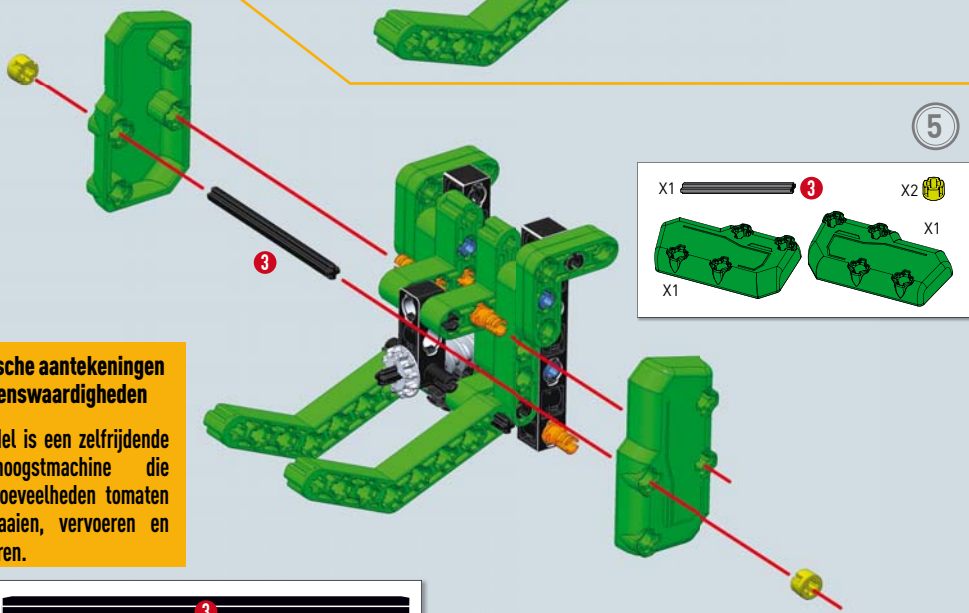

- |    |  |   |    |  |
|----|--|---|----|--|
| X1 |  | 3 | X2 |  |
| X1 |  |   | X1 |  |

**Technische aantekeningen en wetenswaardigheden**

Dit model is een zelfrijdende tomaten oogstmachine die grote hoeveelheden tomaten kan maaien, vervoeren en selecteren.





8

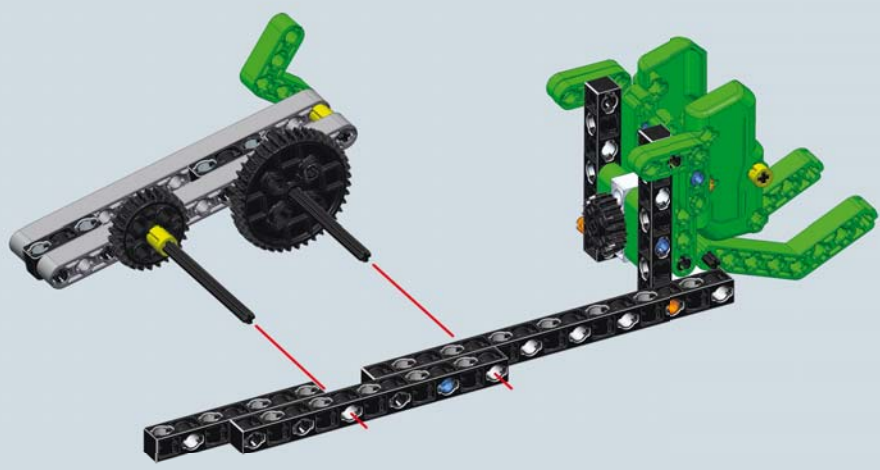

9



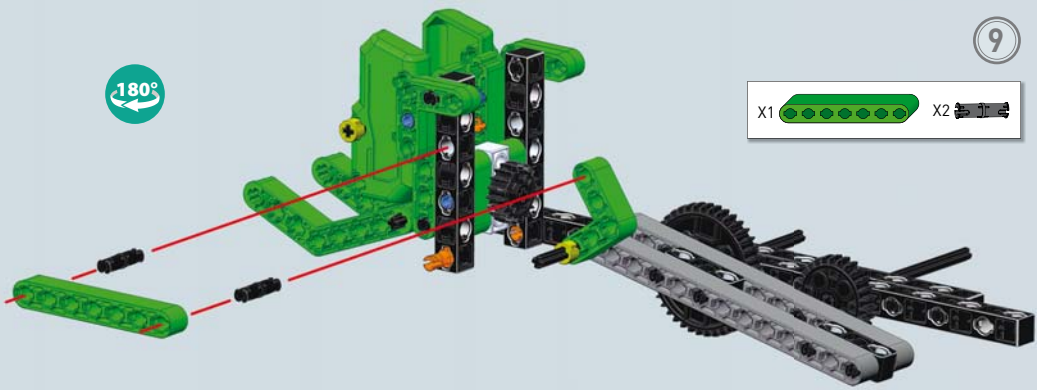



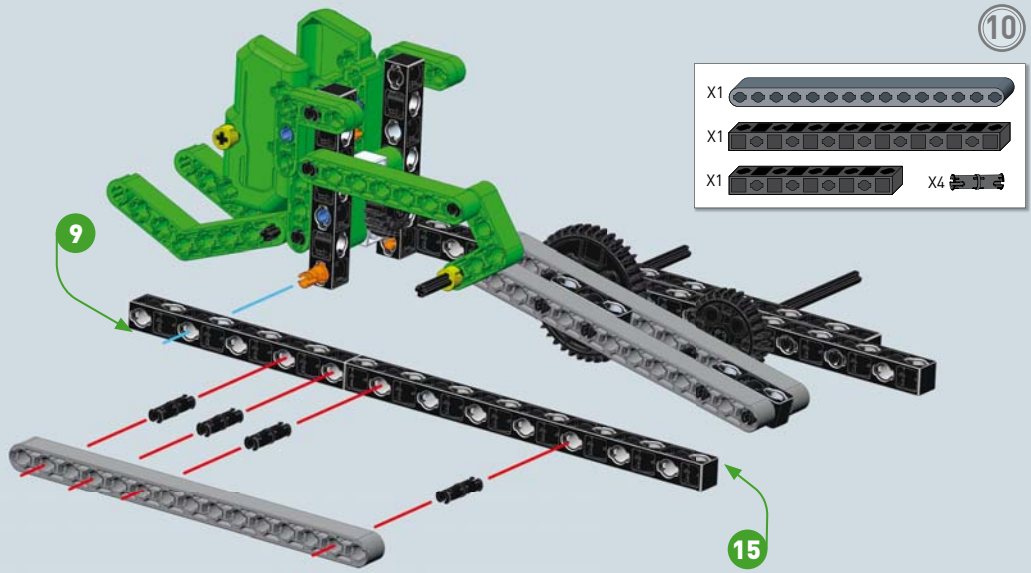

180°



10





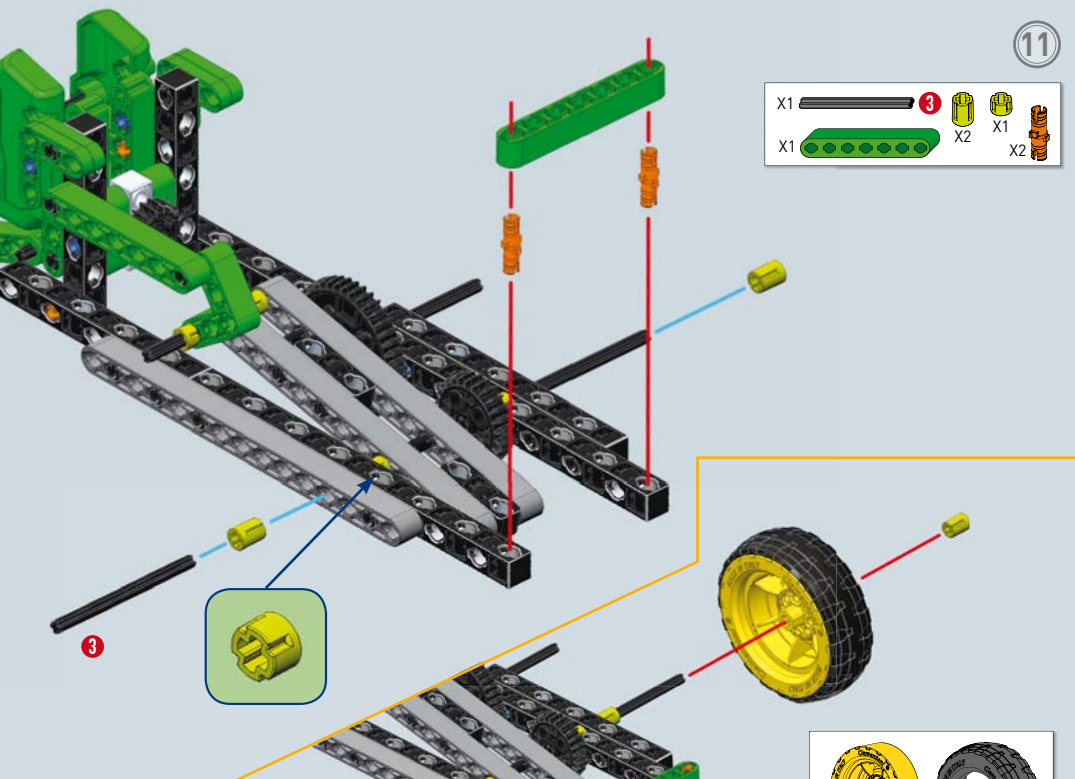

11

- X1  3  X2  X1 
- X1  X2  X1  X2 

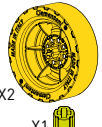

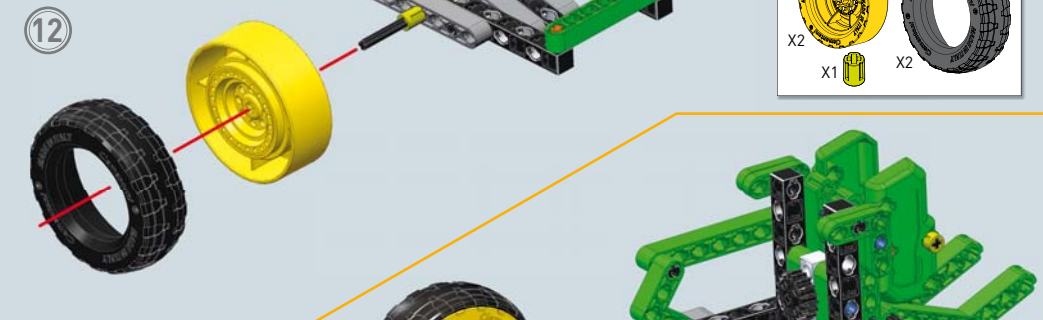

12

- X2  X2 
- X1  X2 



13

- X1 
- X1  X1 

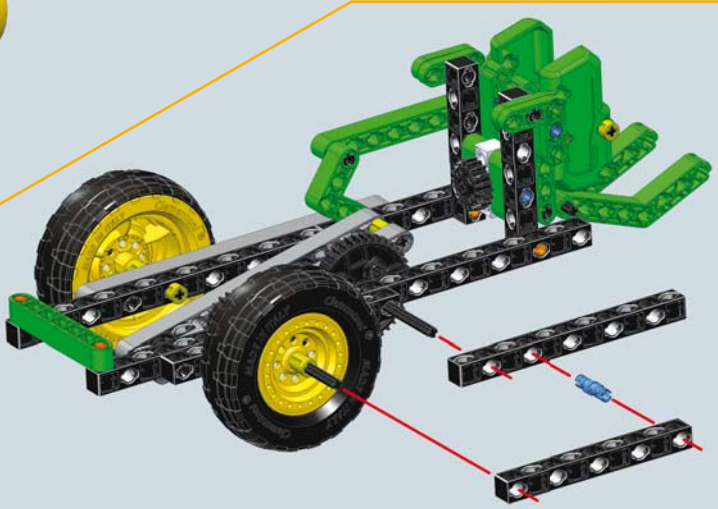



- X1
- X2
- X2

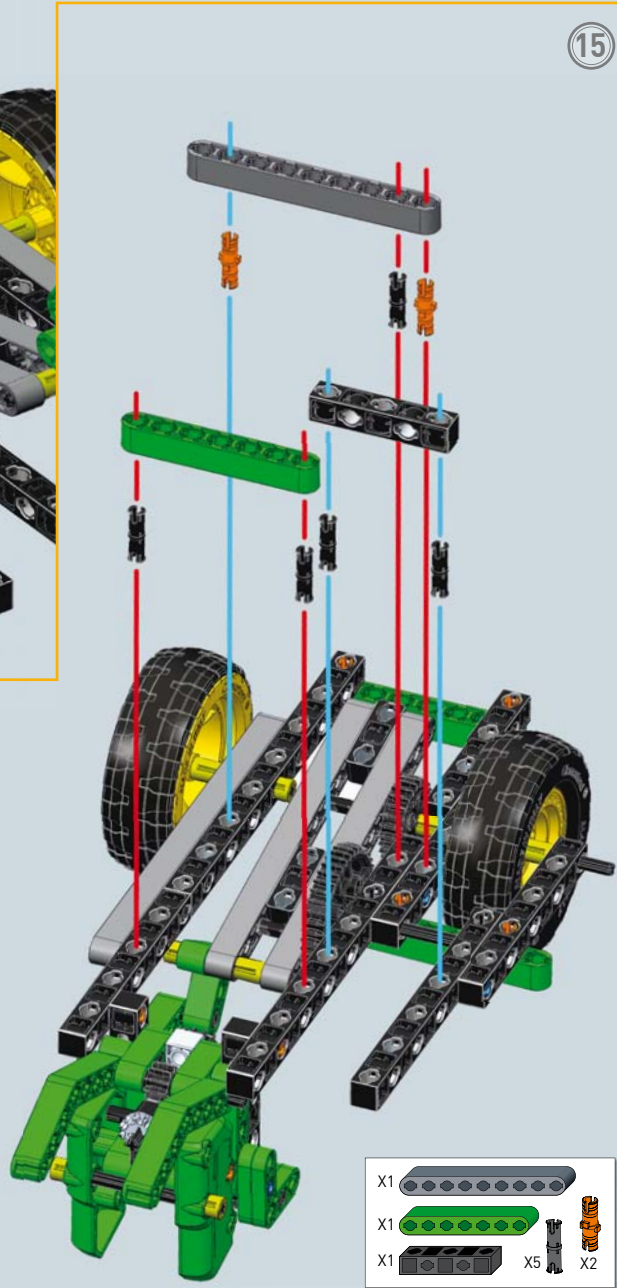
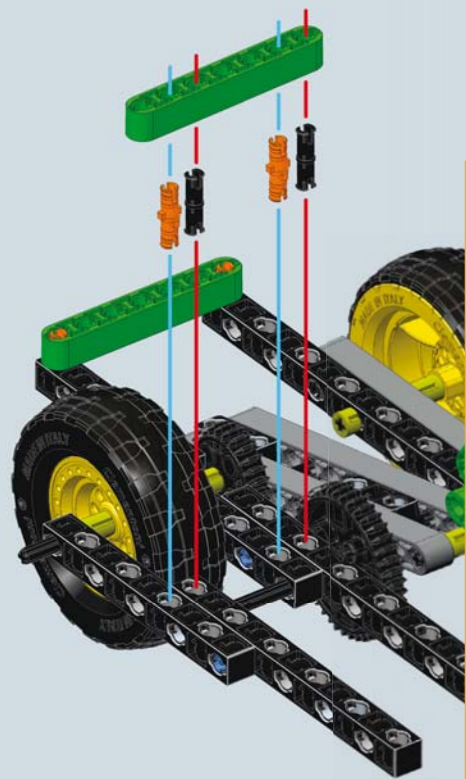

- X1
- X1
- X5
- X2

**Technische aantekeningen en wetenswaardigheden**

De modernste machines kunnen de tomaten op elektronische wijze selecteren door de kleur en de vorm van elke tomaat met speciale fotocellen te beoordelen. Op deze manier kunnen tevens residuen worden afgevoerd die niet geogost moeten worden.

18

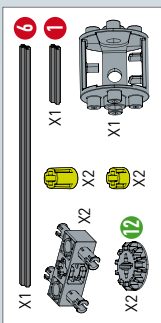
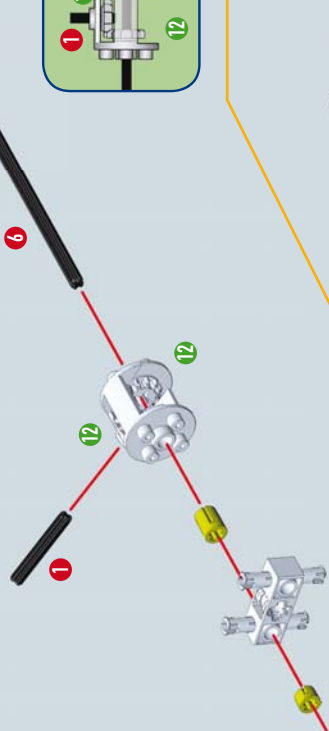
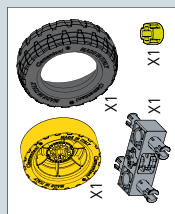
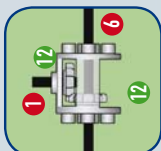
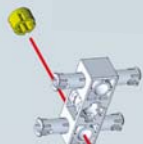
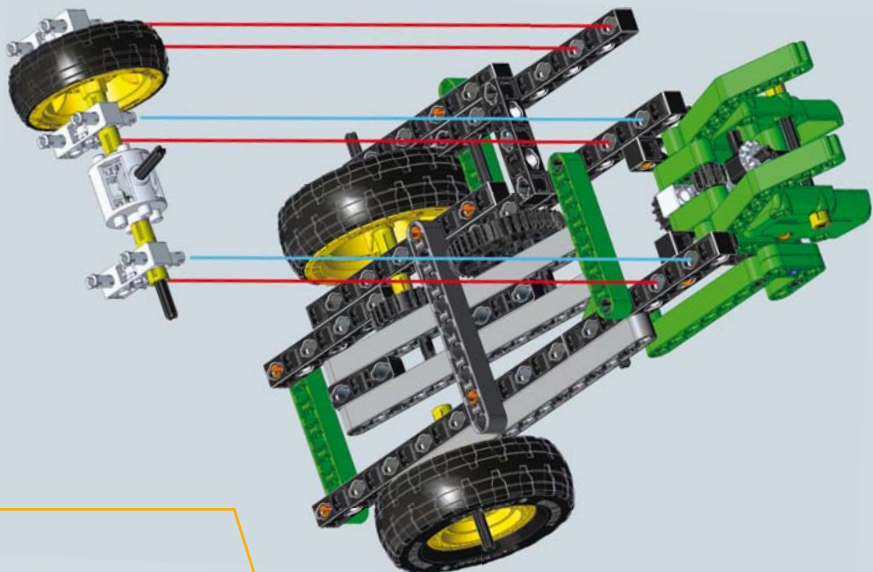

17



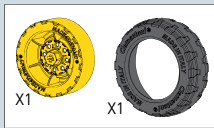

19

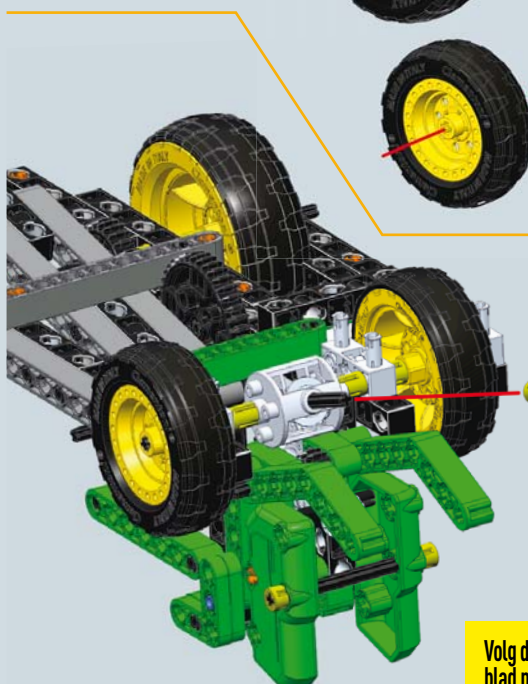
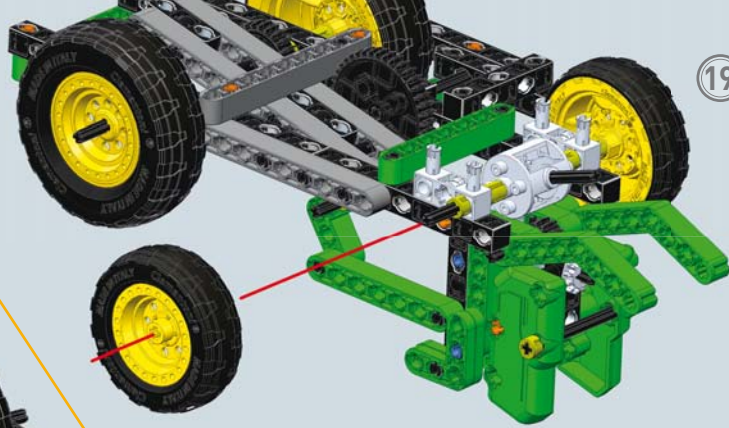

20

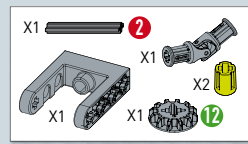

Volg de aanwijzingen op het geïllustreerde blad met waarschuwingen voor de montage van de cardankoppeling.

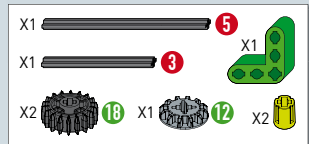

21

180°

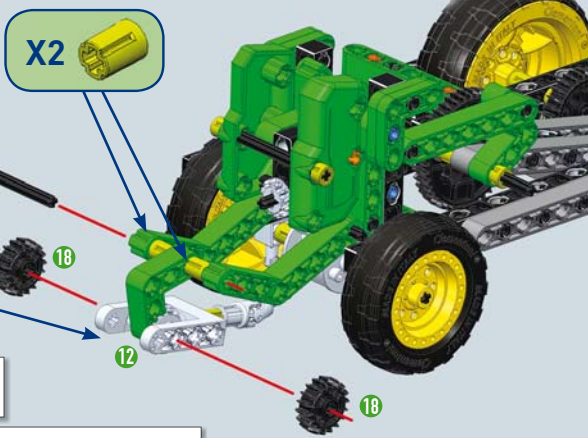
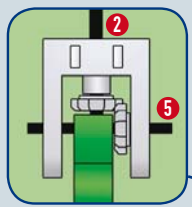

22

- X2
- X4
- X4
- X2
- X2
- X2

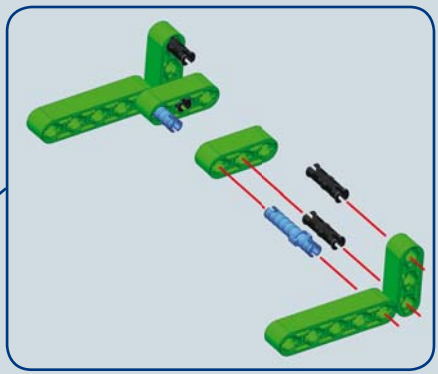
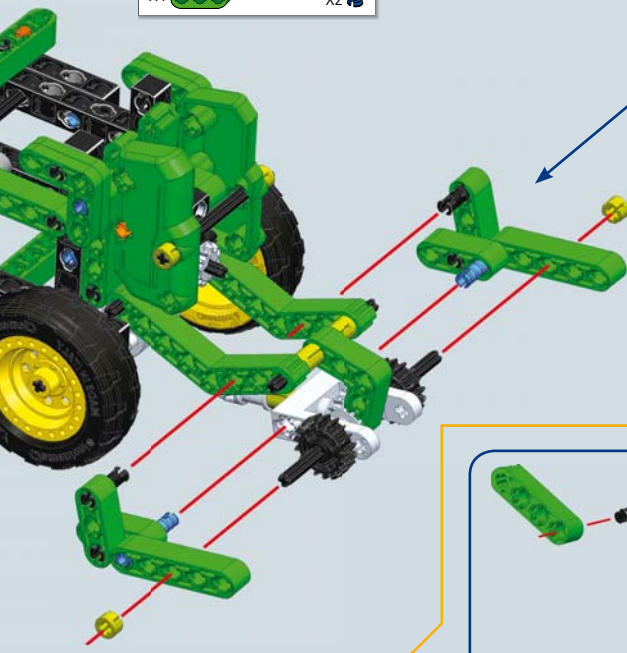

23

- X1
- X1
- X2
- X2
- X1
- X2
- X1

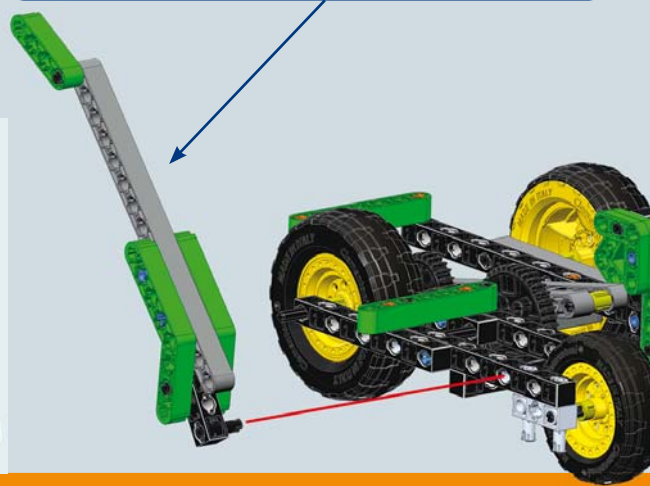
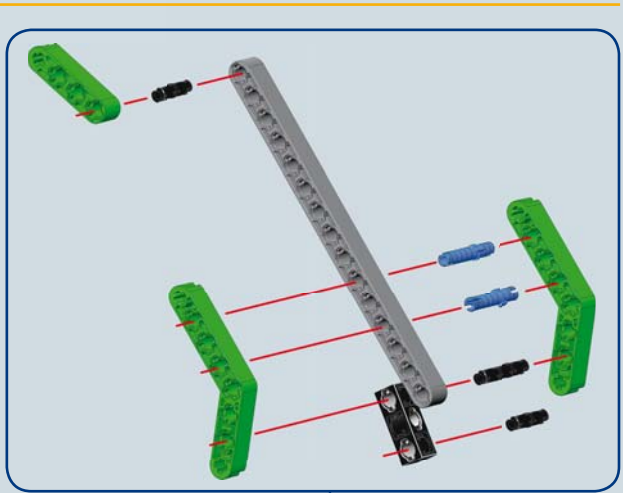

Uiteindelijk model