

# 1

Wetenschap  
& Spel

TECHNOLOGIC

# MECHANICA

## Laboratorium

### REDDINGSVOERTUIGEN

Constructies 1 t/m 3

- 1 - De UTV voor reddingsactiviteiten op het strand
- 2 - De hovercraft
- 3 - De takelwagen



#### WAARSCHUWING:

Om een correcte werking van de elektromotoren te waarborgen is tijdens de productie een kleine hoeveelheid vet in de motoren aangebracht.

Bij hoge temperaturen kan dit vet zacht en vettig worden.

Maak de motoren uit de doos met doekjes schoon als ze vuil worden.

Het gebruikte vet is niet giftig of gevaarlijk.

#### LET OP!

Alleen voor kinderen boven de 8 jaar.

De instructies voor volwassenen zijn inbegrepen en moeten gerespecteerd worden.

LEZEN EN BEWAREN VOOR  
LATERE RAADPLEGING.

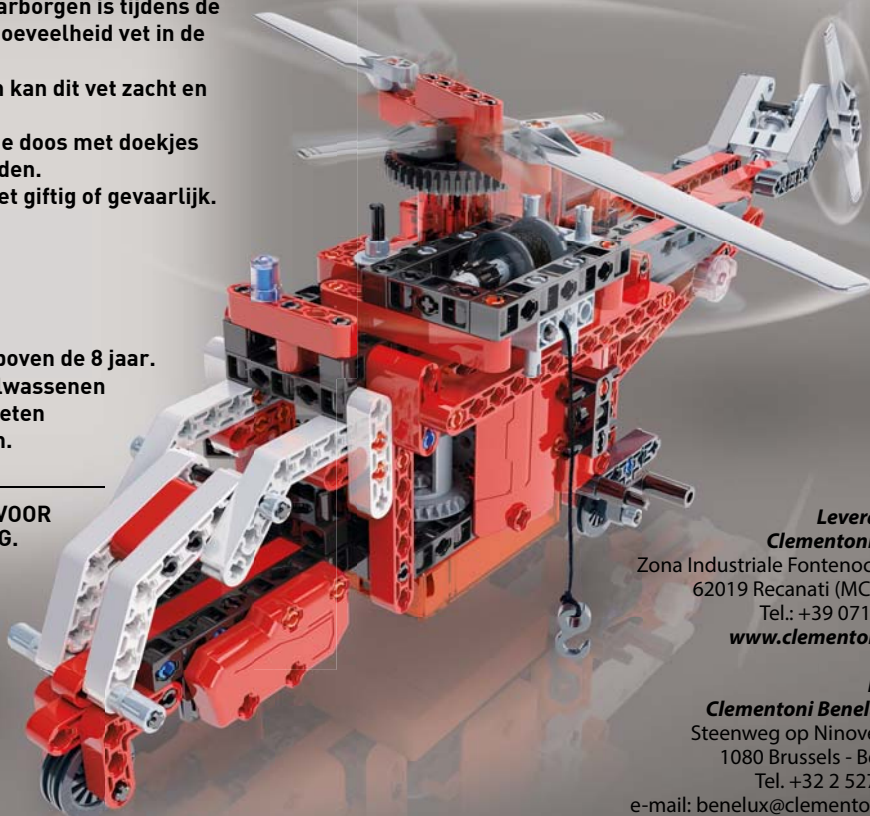

Leverancier:

**Clementoni S.p.A.**

Zona Industriale Fontenoce s.n.c.

62019 Recanati (MC) - Italy

Tel.: +39 071 75811

[www.clementoni.com](http://www.clementoni.com)

Filiaal:

**Clementoni Benelux sprl**

Steenweg op Ninove, 1120

1080 Brussels - Belgium

Tel. +32 2 527 31 96

e-mail: [benelux@clementoni.com](mailto:benelux@clementoni.com)

**AANWIJZINGEN VOOR DE TOEZICHTHOUDENDE OUDERS:** dit speelgoed is geschikt voor kinderen van 8 jaar en ouder. Voor de montage van het instrument en tijdens de hantering en installatie van de elektrische onderdelen is de aanwezigheid van een volwassene aanbevolen.

## VERWIJDERING EN INSTALLATIE VAN DE BATTERIJEN

Zorg ervoor dat het toestel uitgeschakeld is.

- 1 Gebruik een universele schroevendraaier om de schroef los te draaien die het deksel van het batterijcompartiment fixeert.
- 2 Verwijder de lege batterijen.
- 3 Voer de nieuwe in (4 x 1,5 V AAA/LR03) volgens het polenteken op het compartiment zelf.
- 4 De batterijen moeten ingevoerd worden door een volwassene.
- 5 Sluit het deksel van het compartiment opnieuw, door de schroef opnieuw aan te draaien.
- 6 Controleer of het toestel werkt.

## HOE VOEGT MEN DE BATTERIJEN IN

Vraag hulp aan een volwassene!

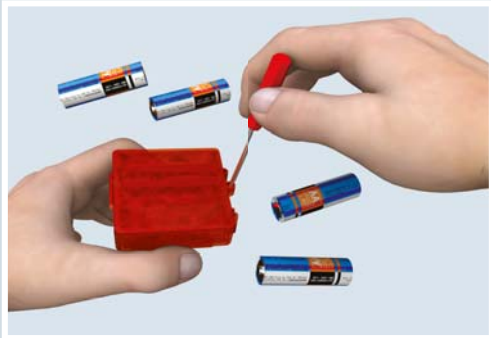

**Voeding:** : D.C. 6V

**Batterijen:** 4 x 1,5V AA/LR6

(niet in de verpakking bijgesloten)

## ANDERE AANBEVELINGEN:

- De batterijen zijn gevaarlijk wanneer ze worden ingeslikt, houd ze daarom ver buiten het bereik van kinderen.
- Als het spel voor langere tijd niet gebruikt wordt verwijder dan de batterijen.
- Probeer de batterijen niet te openen.
- Werp de batterijen niet in het vuur.

## AANWIJZINGEN VOOR EEN CORRECT GEBRUIK VAN SPELLETJES MET VERVANGBARE BATTERIJEN

- De batterijen moeten in de goede richting geplaatst worden (-) en (+) overeenkomstig met de merktekens op de batterijen.
- Leeggelopen batterijen uit het speelgoed halen.
- De voedingsklemmen mogen niet worden kortgesloten.
- Raak, ter voorkoming van kortsluiting, de contacten in het batterijvak op geen enkele manier aan.
- Verwijder de oplaadbare batterijen uit het spel voor het opladen. Oplaadbare batterijen mogen uitsluitend onder toezicht van een volwassene worden opgeladen.
- Probeer niet om niet-oplaadbare batterijen toch op te laden.
- Verschillende soorten batterijen of nieuwe en reeds gebruikte batterijen niet mengen.

## RICHTLIJNEN VOOR DE VERWIJDERING VAN BATTERIJEN



Het symbool geeft aan dat lege batterijen in overeenstemming met de geldende wettelijke milieuvorschriften behandeld moeten worden. De scheikundige symbolen voor kwik (Hg), cadmium (Cd) en/of lood (Pb) onder het symbool van de doorgekruiste vuilnisbak geven aan dat de batterij een aanzienlijk percentage van deze stof bevat. Deze stoffen zijn schadelijk voor de gezondheid en het milieu. Door een correcte verwijdering van de batterijen kunnen de schadelijke stoffen worden geïsoleerd en op passende wijze worden behandeld. Een correcte verwijdering bevordert de recyclage van de waardevolle grondstoffen en beperkt de schadelijke effecten op personen en het milieu. Door uitgeputte batterijen naar de vuilstort te brengen of in het milieu te lozen, neemt het gevaar voor de vervuiling van grond- en oppervlaktewateren aanzienlijk toe. In overeenstemming met de Europese richtlijn 2013/56/EU is het verboden om accu's en batterijen bij het huisvuil te doen. Consumenten moeten deze producten gescheiden inzamelen om de behandeling en recyclage ervan te bevorderen.



## HOE BATTERIJEN VERWIJDEREN:

- Laat de batterijen volledig leeglopen door het apparaat in te schakelen tot de batterijen uitgeput zijn, alvorens de batterijen weg te gooien.
- Verwijder de batterijen uit het apparaat.
- Verwijder de batterijen conform de toepasselijke normen door de verzameling in specifieke houders of door ze te brengen naar een erkend inzamelcentrum of in te leveren bij de winkelier waar de batterijen zijn gekocht. Batterijen kunnen gratis worden ingeleverd!
- De illegale lozing van batterijen is strafbaar.



## INSTRUCTIES VOOR DE LOZING VAN ELEKTRISCHE EN ELEKTRONISCHE APPARATUUR ONDERWORPEN AAN DE INZAMELING VAN GESCHIEDEN AFVAL.

**BELANGRIJK!** Het symbool  van de doorgekruiste vuilnisbak geeft aan dat alle componenten van het product waar dit symbool op is aangebracht (of die als dusdanig in de spelaanwijzingen zijn beschreven) gescheiden moeten worden ingezameld binnen de lidstaten van de Europese Unie (richtlijn 2012/19/EG) en in alle landen die een gescheiden afvalinzameling toepassen. Het is verboden om dergelijke componenten bij het normale huisvuil te doen.

## HOE AEEA VERWIJDEREN:

- 
- Uitsluitend componenten, voorzien van dit symbool  (of die als dusdanig in de documentatie zijn beschreven) dienen verplicht gescheiden te worden ingezameld en naar erkende afvalverwerkingsbedrijven te worden gebracht. Het is echter ook mogelijk, waar toegestaan, om het te verwijderen product bij de aankoop van een soortgelijk apparaat bij de winkel in te leveren als de buitenafmetingen van het product kleiner dan 25 cm groot zijn.
  - De gebruikers van het product spelen een belangrijke rol in het bevorderen van de correcte verwijdering van elektrische en elektronische apparatuur aan het einde van de nuttige levensduur. Daarom is het belangrijk dat elke gebruiker zich van zijn/haar rol bewust is en elektrisch/elektronisch afval altijd verwijdert conform de toepasselijke wetgeving. Op deze manier draagt hij/zij bij aan een correct afvalbeheer en worden het hergebruik, de recyclage en/of de terugwinning bevorderd.

## Waarschuwing!

- 
- De componenten voorzien van het symbool  bevatten stoffen die schadelijk zijn voor de gezondheid en het milieu. Het is verboden ze te stoppen bij het ongescheiden stadsafval of het normale huisvuil. Een niet-correcte verwijdering kan het milieu schaden en is strafbaar.
  - Het is verboden ze te stoppen bij het ongescheiden stadsafval of het normale huisvuil. Een niet-correcte verwijdering kan het milieu schaden en is strafbaar. Het is verboden deze componenten te gebruiken op een onjuiste manier en in het bijzonder is het verboden de elektrische en elektronische componenten van het spel te demonteren en het spel te gebruiken indien het beschadigd is. Dit kan schadelijk zijn voor de gezondheid.

**N.B. Hetgeen hierboven wordt aangegeven betreft uitsluitend de componenten van het spel (of diegene die in de documentatie worden aangeduid) gemarkeerd met het symbool .**

## Waarschuwing!

De andere componenten van het spel (kaarten, accessoires enz.) en de verpakking zijn niet onderworpen aan de voornoemde aanwijzingen en kunnen samen met het andere huisafval geloosd worden. Ze hoeven dus niet naar inzamelcentra voor elektrisch en elektronisch afval gebracht worden of aan de winkelier gerestitueerd worden bij de aankoop van een nieuw product.

De (niet-professionelen) professionelen worden verzocht contact op te nemen met hun verkoper, met de openbare diensten voor het lozen van afval of met de Klantendienst van **CLEMENTONI S.p.A. (Tel. +39 071 75811; fax +39 071 7581234; e-mail: info@clementoni.it)** voor alle inlichtingen m.b.t. de correcte lozing van het product.



Bouw nu je modellen met de App van het Mechanica Laboratorium. De interactieve animatiefilmpjes zijn eenvoudig en leuk en helpen je tijdens de montage.



**JE BELEEFT NOG MEER PLEZIER DOOR DE 35 ACTIVITEITEN OP ONZE WEBSITE TE DOWNLOADEN**

Hier vind je alle instructies om talrijke experimenten uit te voeren en om de principes uit de fysica en mechanica uit te diepen

[www.mechanicallaboratorium.clementoni.com](http://www.mechanicallaboratorium.clementoni.com)

**DE BELEGERINGSWAPENS**

**DE STORMRAM**



**DE HELIKOPTERROTOR**



**DE KATAPULT**



**DE HEFBOMEN**

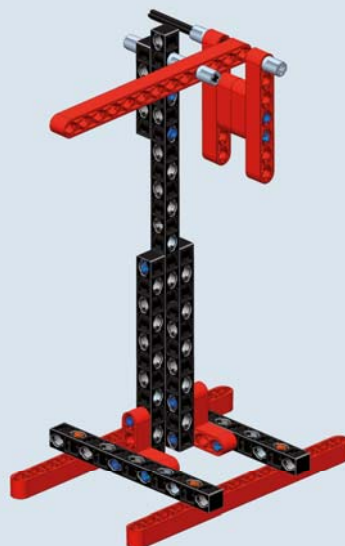
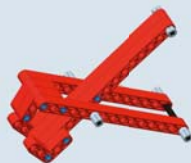



# 1 De UTV voor reddingsactiviteiten op het strand



UTV's (Utility Task Vehicle) zijn zeer geschikt voor toezicht en reddingsactiviteiten op het strand, omdat ze makkelijk manoeuvreerbaar zijn op een klein oppervlak en op ontoegankelijke terreinen. Het verschil met een normale quad is dat de UTV 2 tot 6 personen aan boord kan vervoeren, waarbij er vooraan 2 personen zij-aan-zij kunnen zitten, vandaar ook de Engelse benaming "Side by Side".

Sommige moderne modellen hebben tot 6 wielen of zelfs 4 rupsbanden.

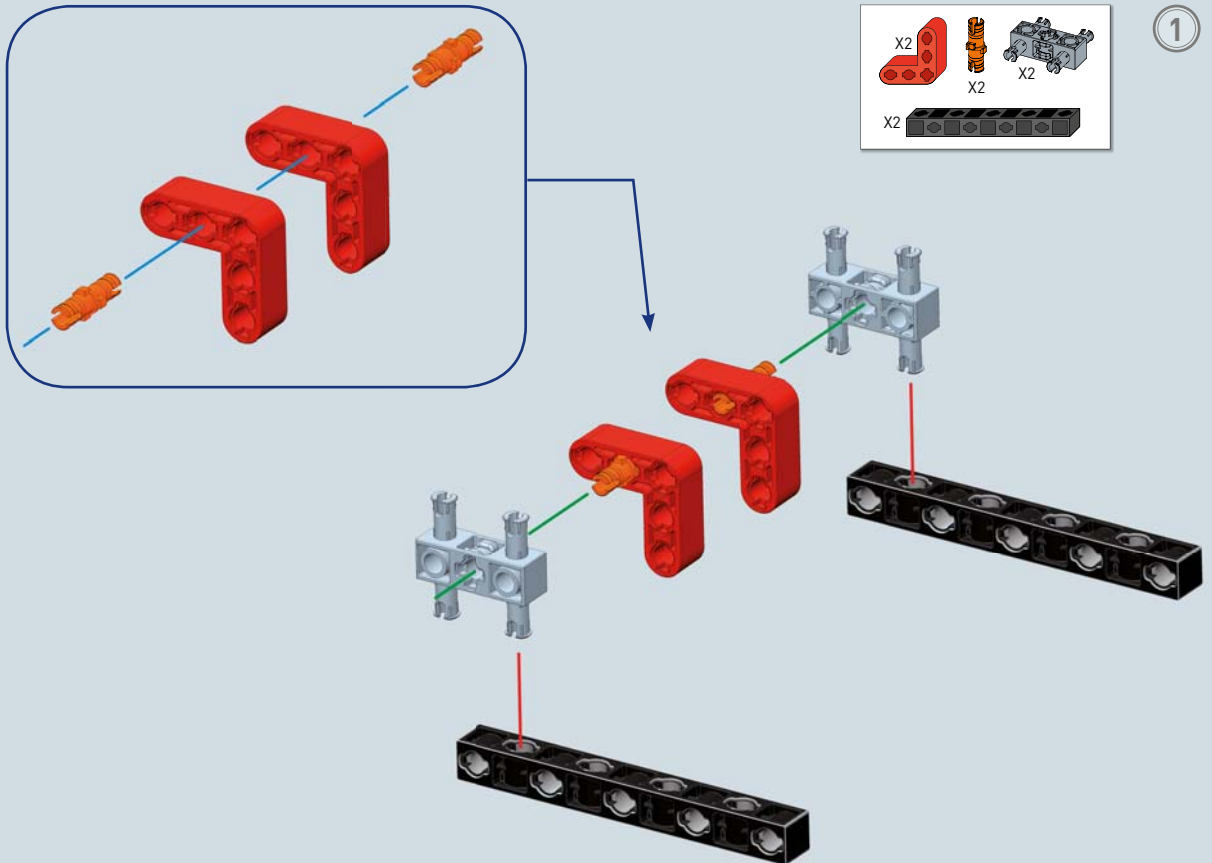

2

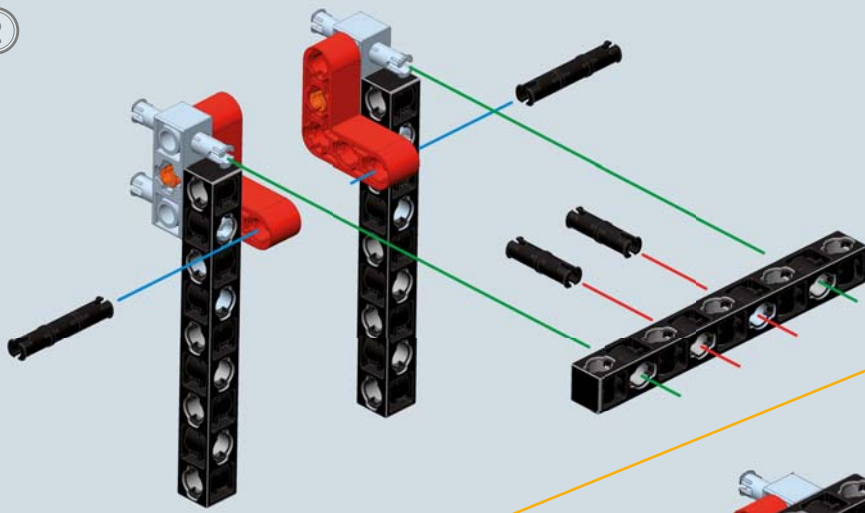

- X2
- X2
- X1

3

- X1
- X2

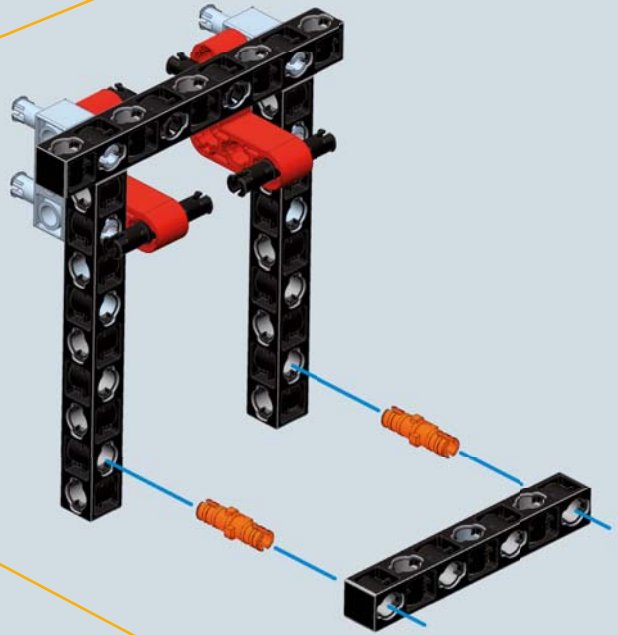

4

- X4
- X2

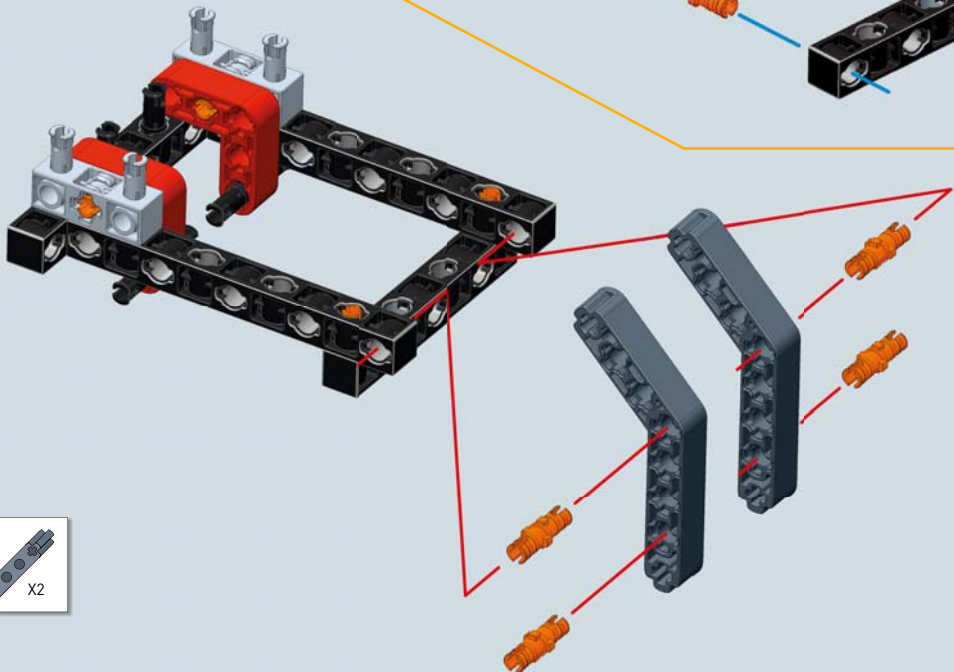

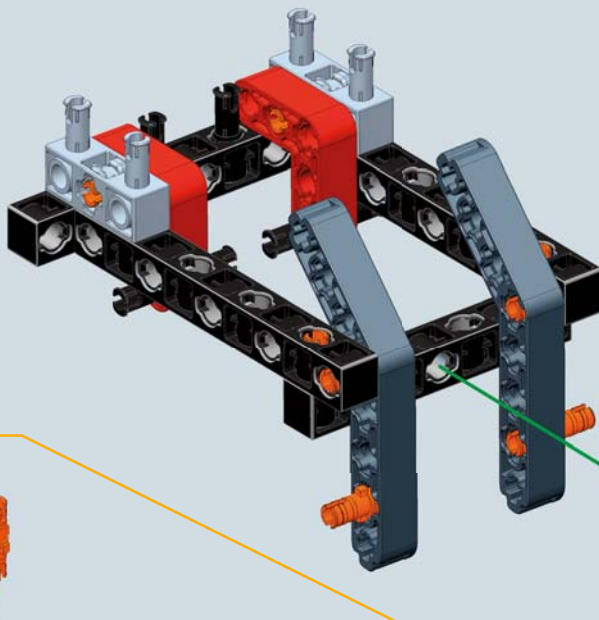

- X2
- X1

5

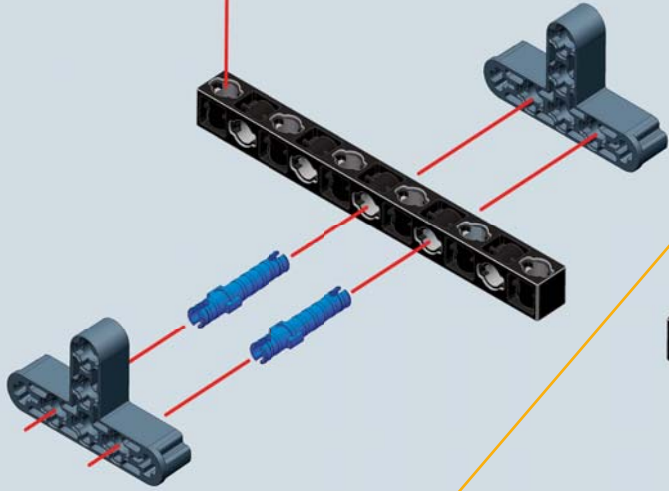
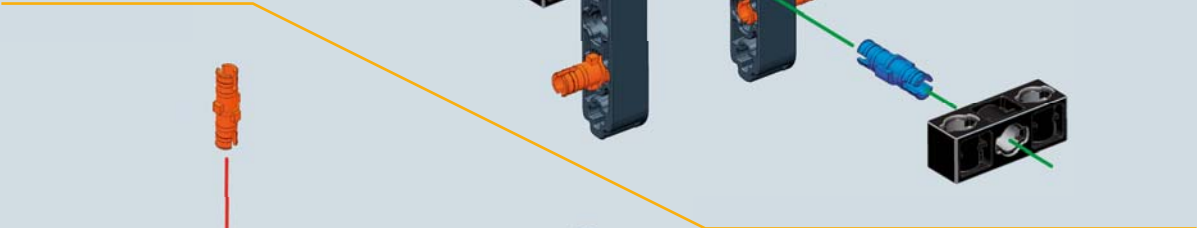

- X2
- X1
- X2
- X1

6

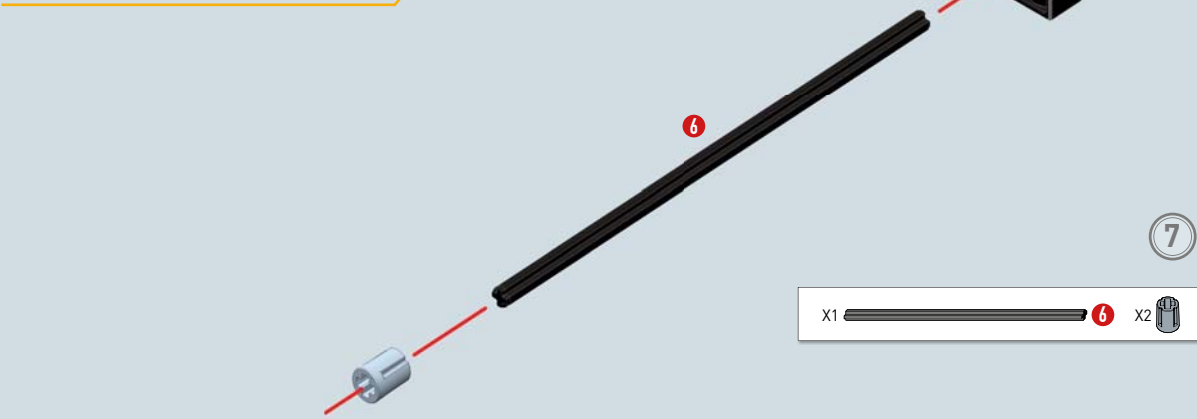
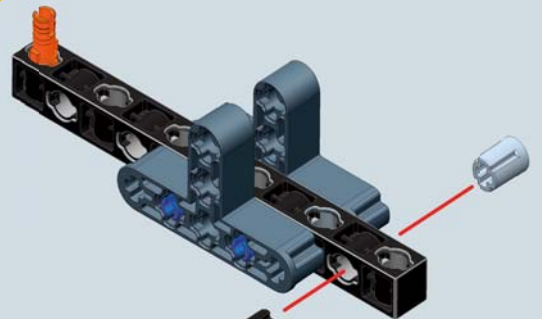

- X1
- X2

7





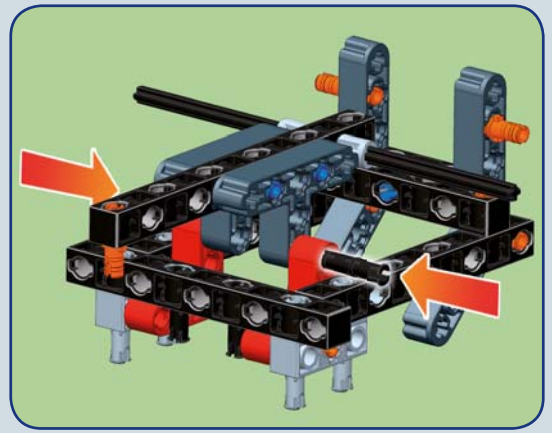
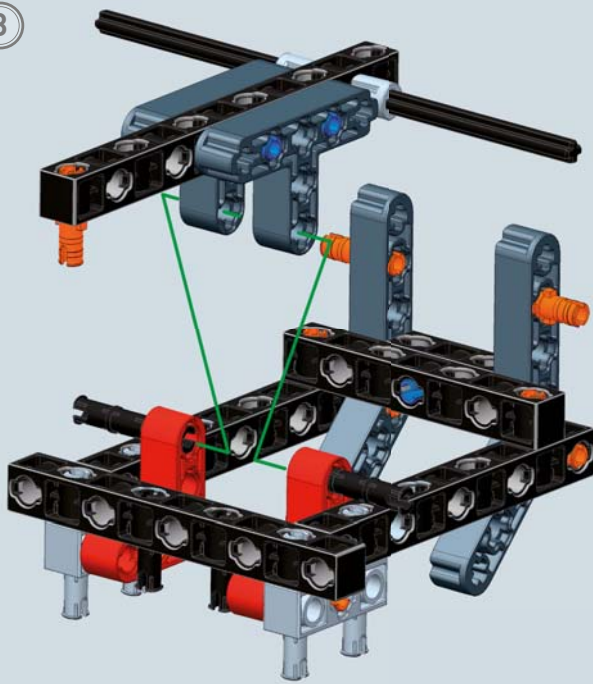

1:1

8



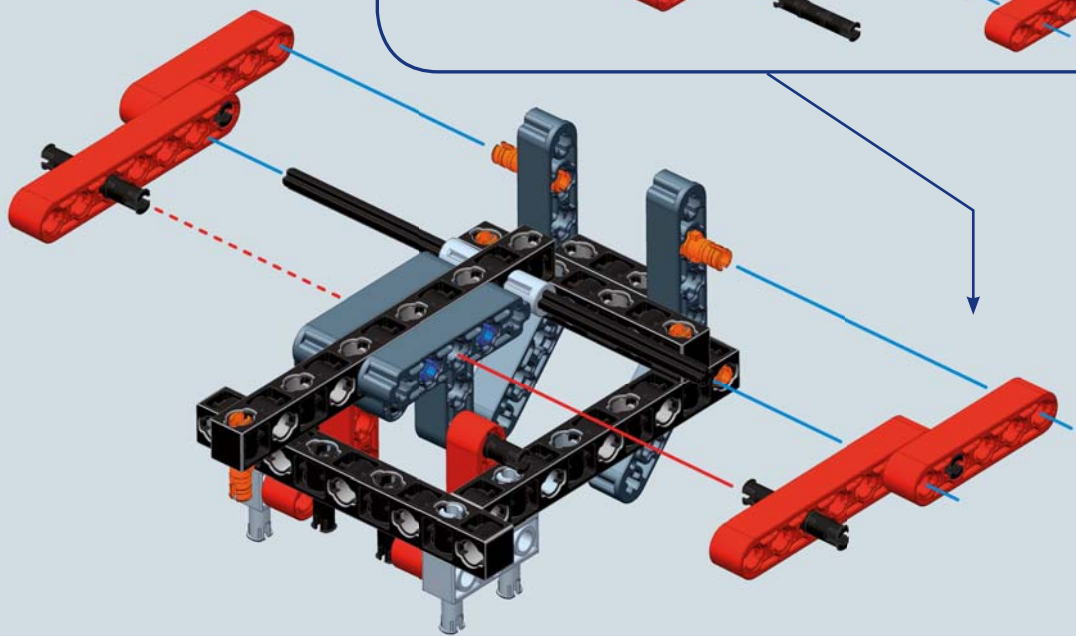
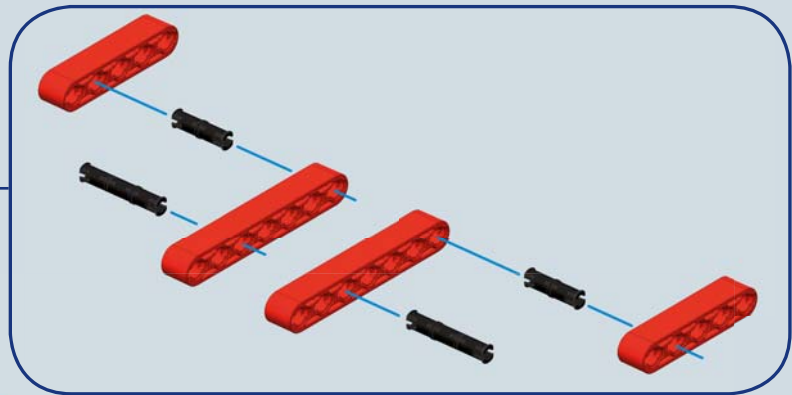

9

- X2  X2 
- X2  X2 



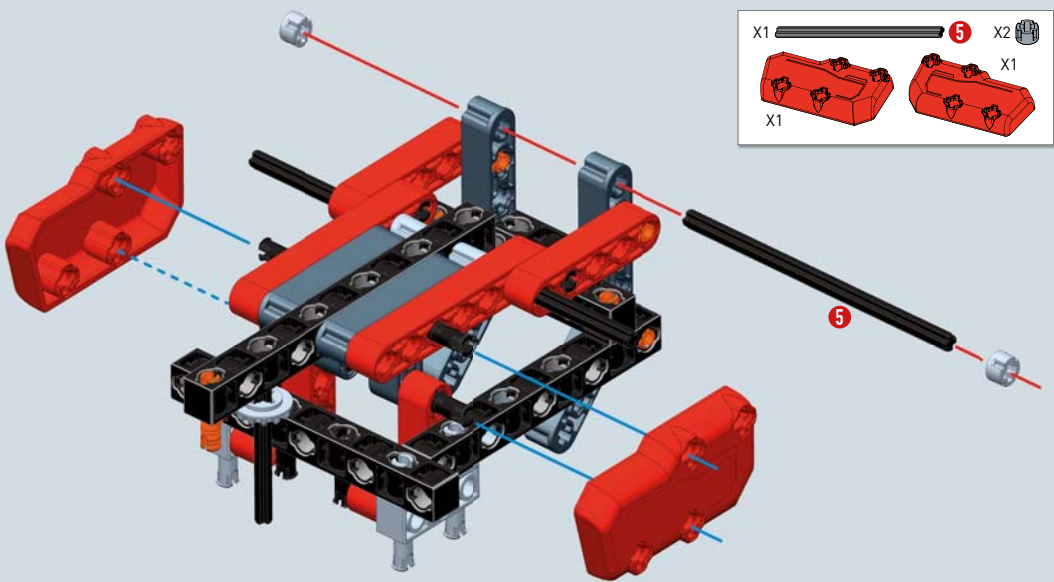





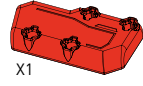
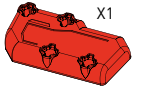

X1  **5** X2 

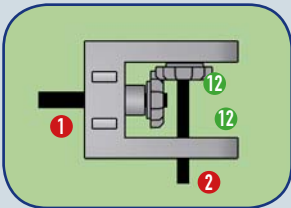

X1  X1 

10

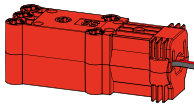

X1  **1** X1  **2**

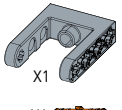
X1  X1  **12** X2 

X1  X1 

11

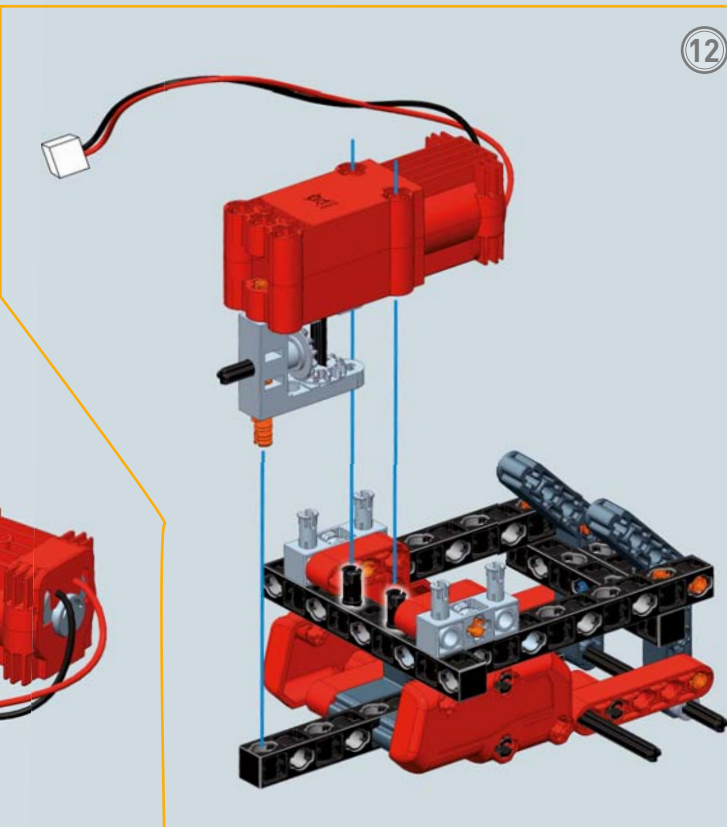
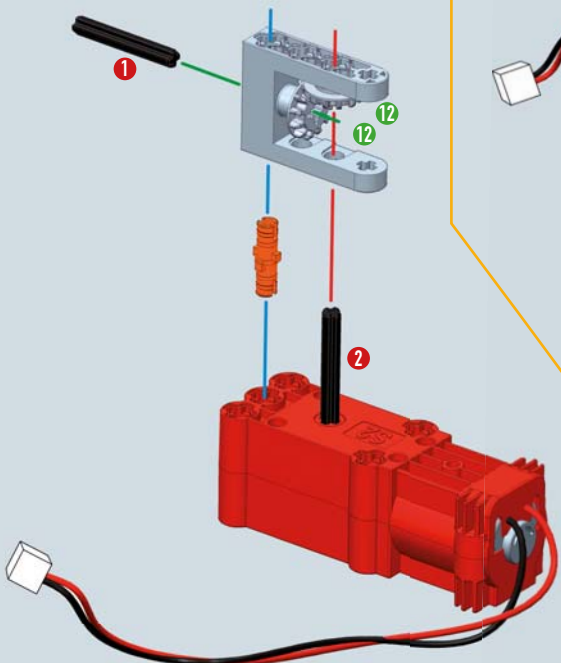

12

1:1  **1**

1:1  **2**

1:1  **5**

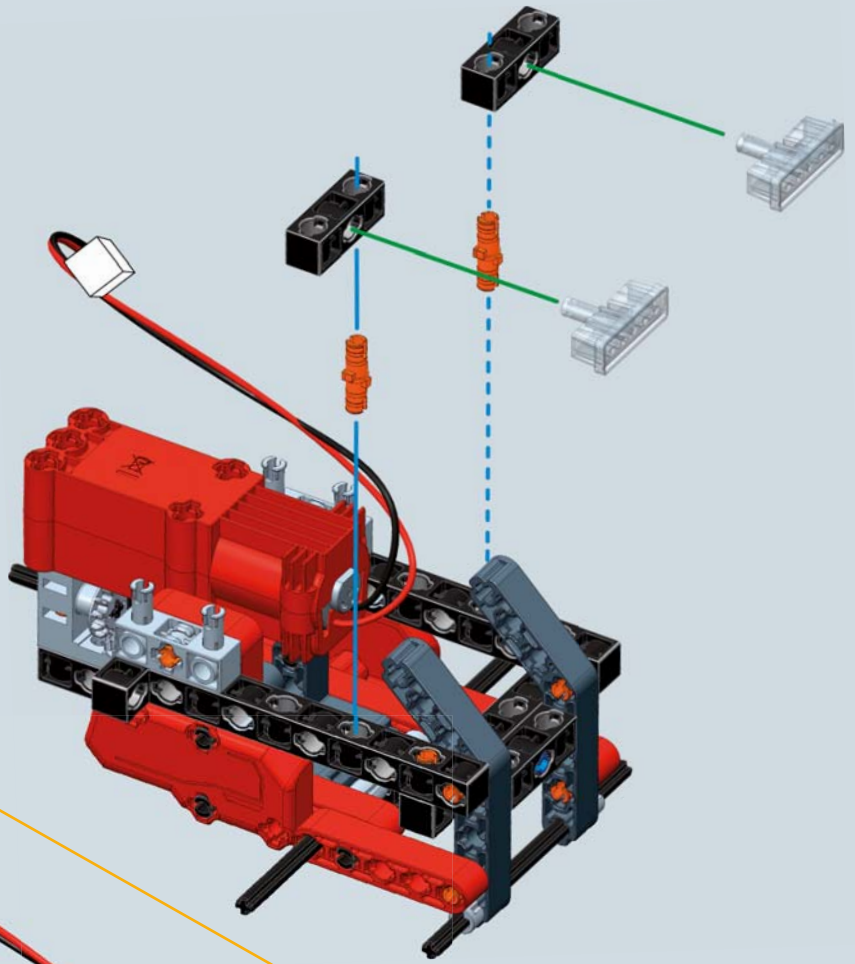
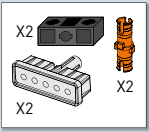

13

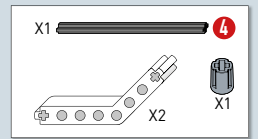
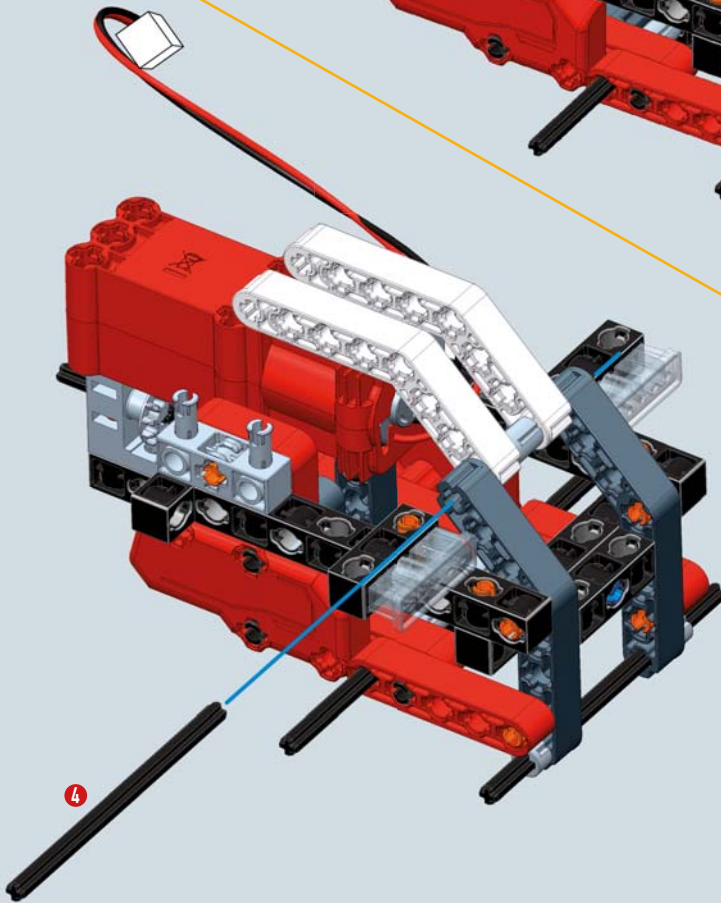

14



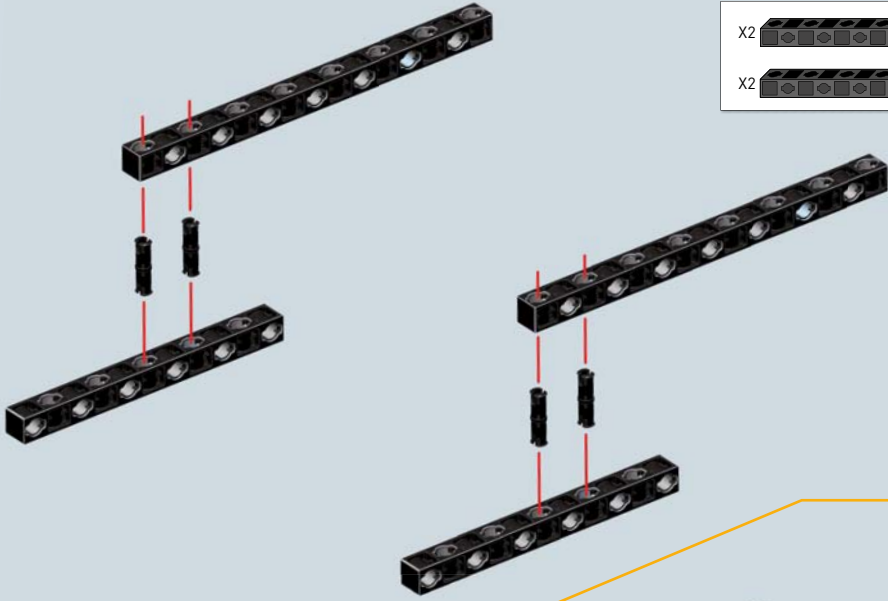

15

- X2  X4 
- X2 



16

- X4 
- X4 

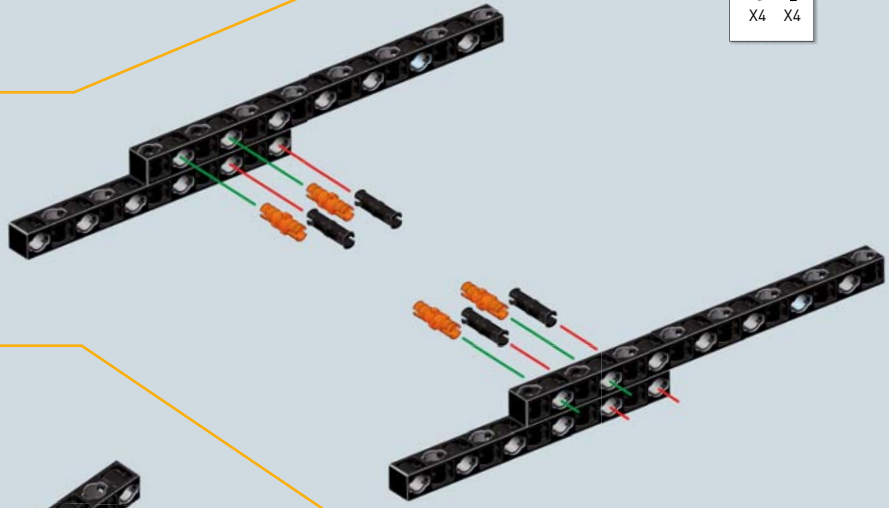

17

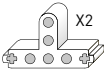
- X2 

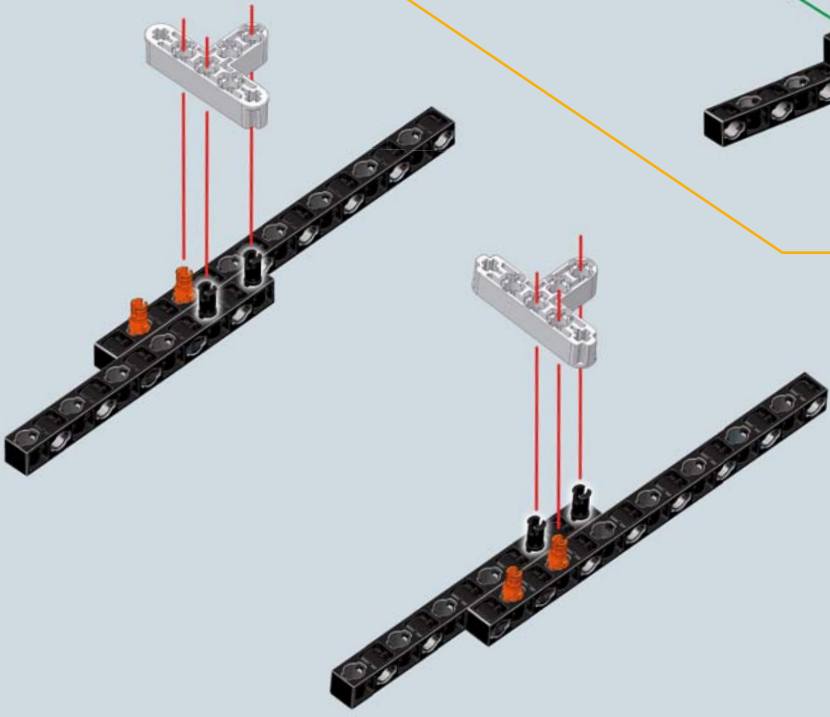

18

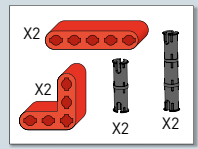
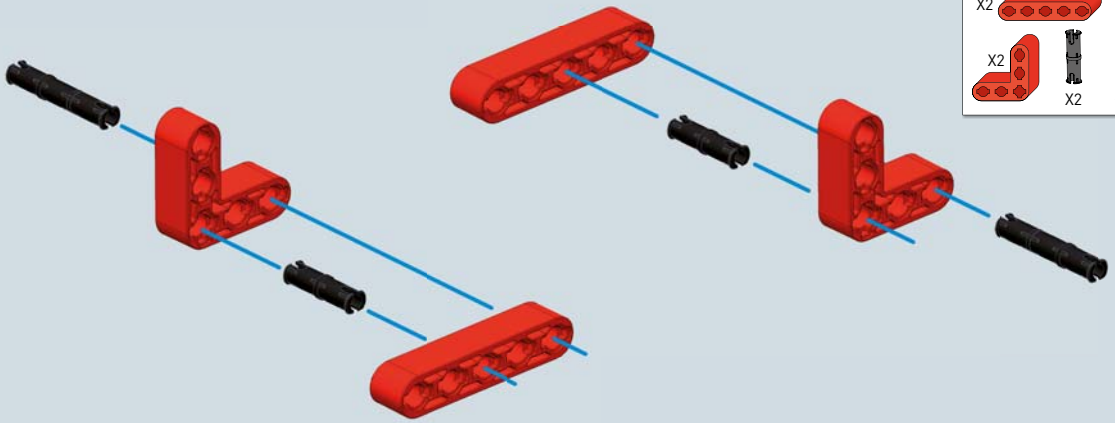

19

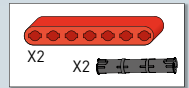
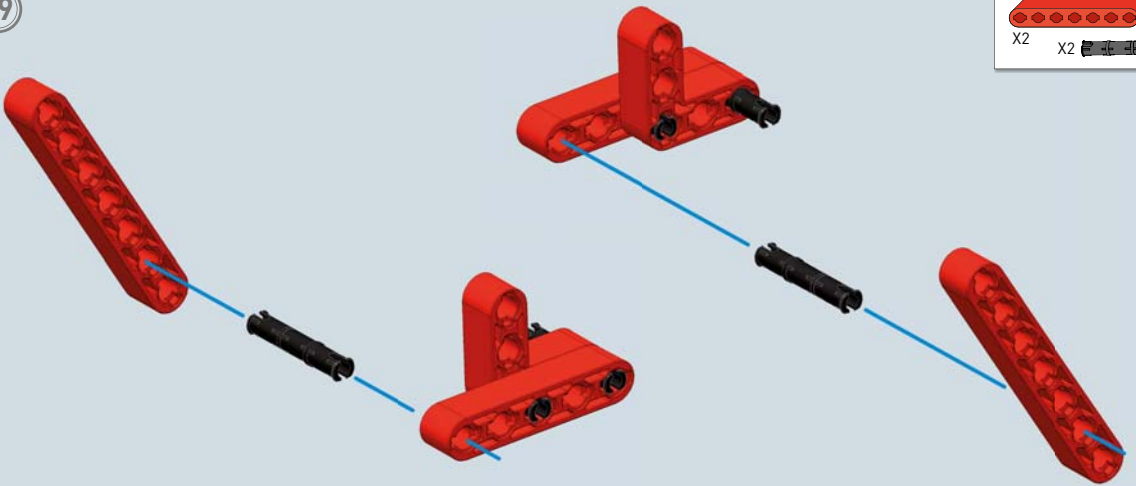

20

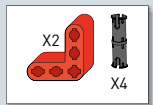
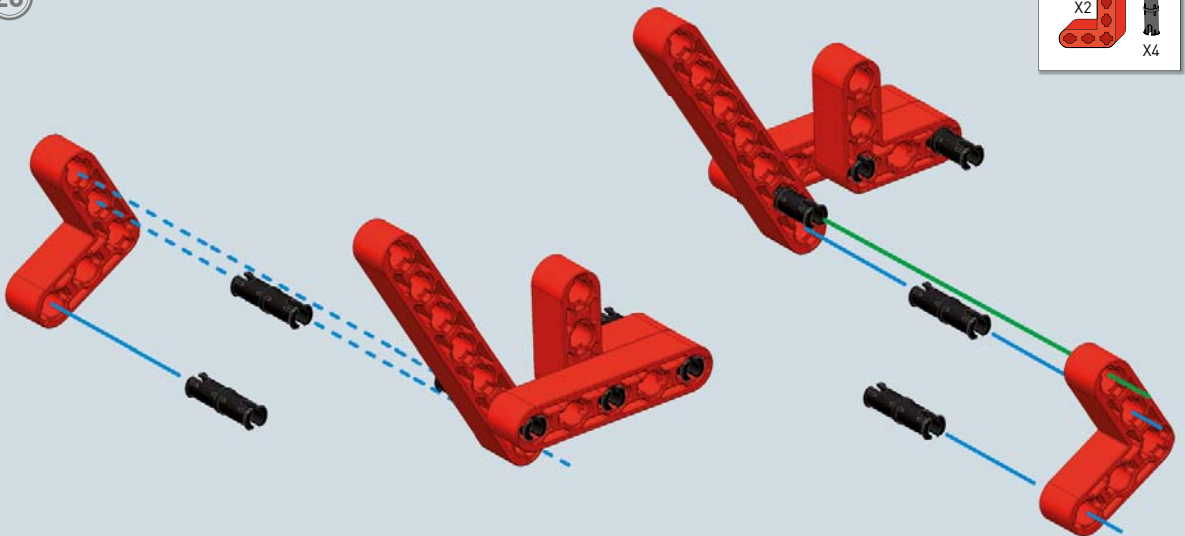



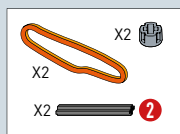
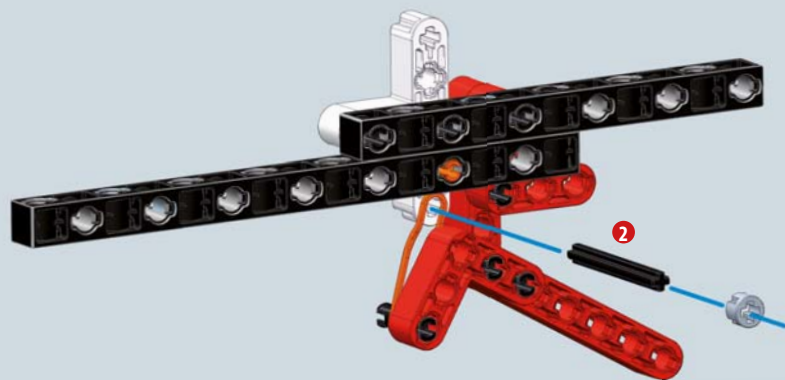

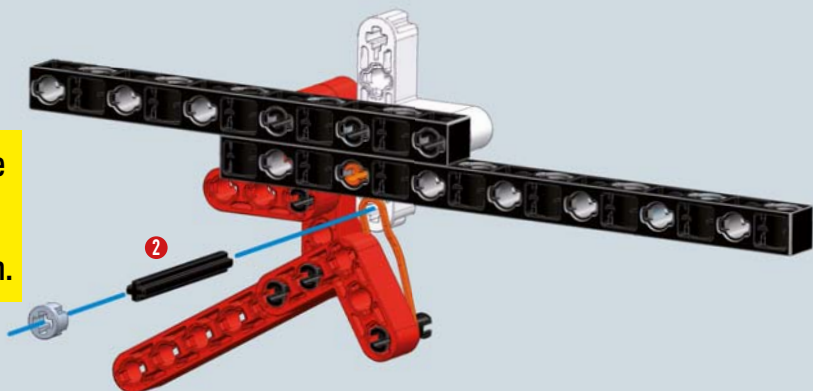

Span de elastiekjes rond de kleine zwarte spijkers en blokkeer ze door het stangetje 2 in het gat afgebeeld op de tekening te steken.





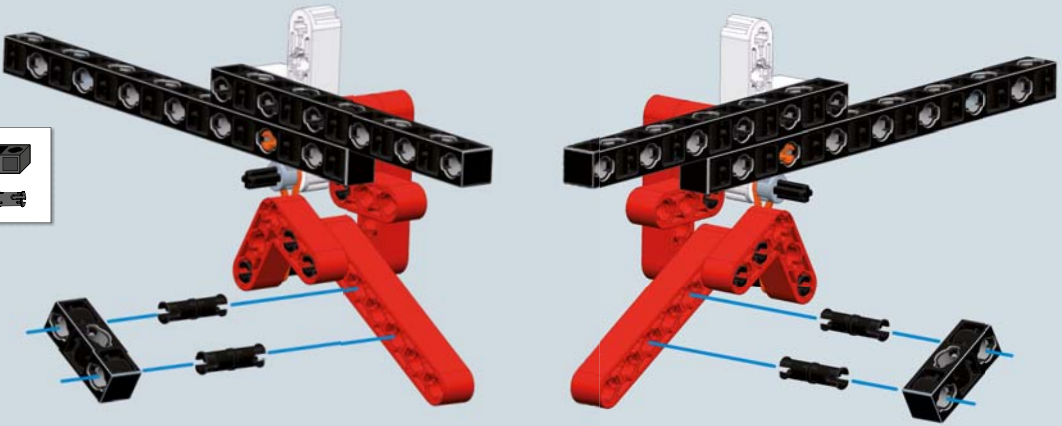

23

- X2 
- X4 





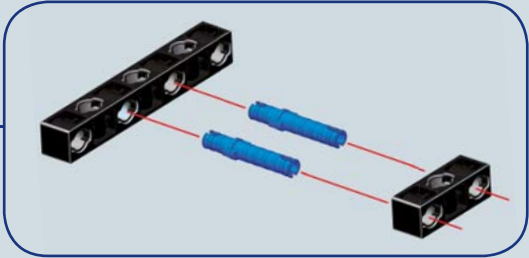
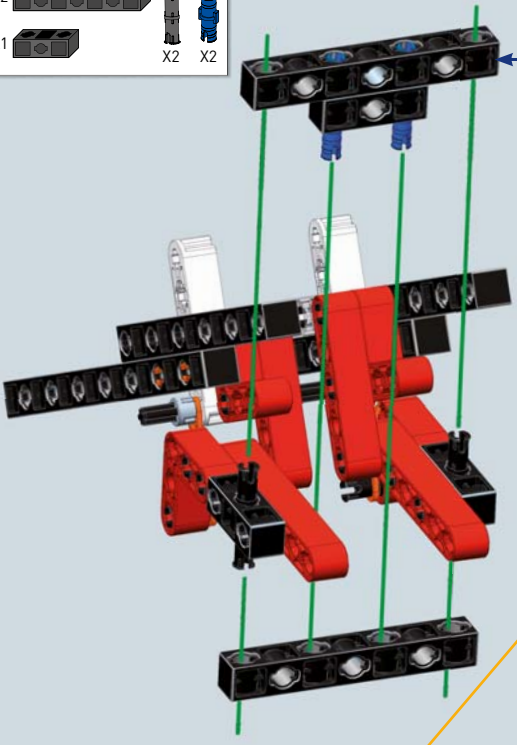

24

- X2 
- X1 
- X2 
- X2 





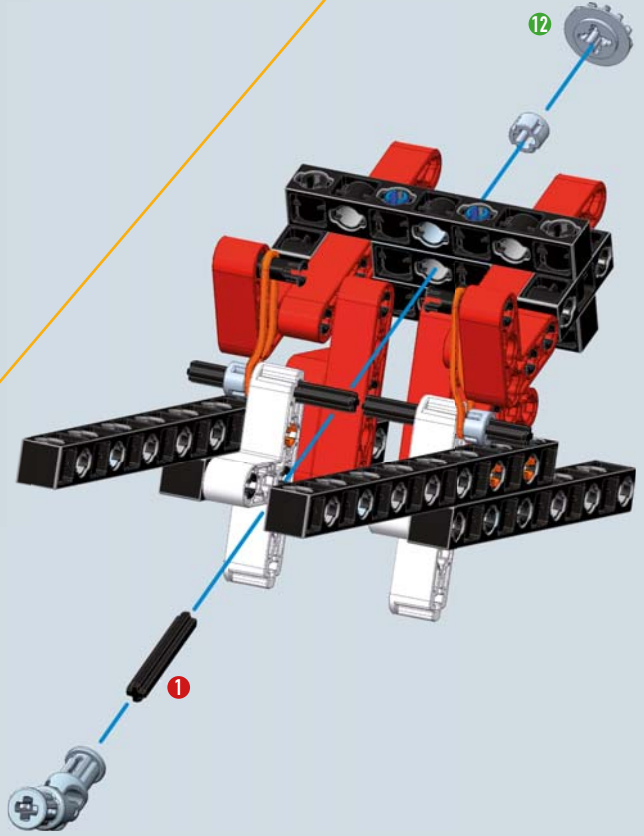

25

- X1 
- X1 
- X1 
- X1 



Monteer de cardankoppeling volgens de instructies vermeld op het blad met waarschuwingen.

- X1  6
- X1  12
- X3 
- X2 

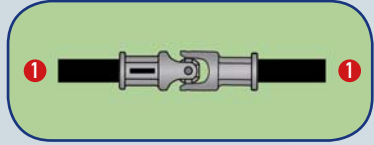
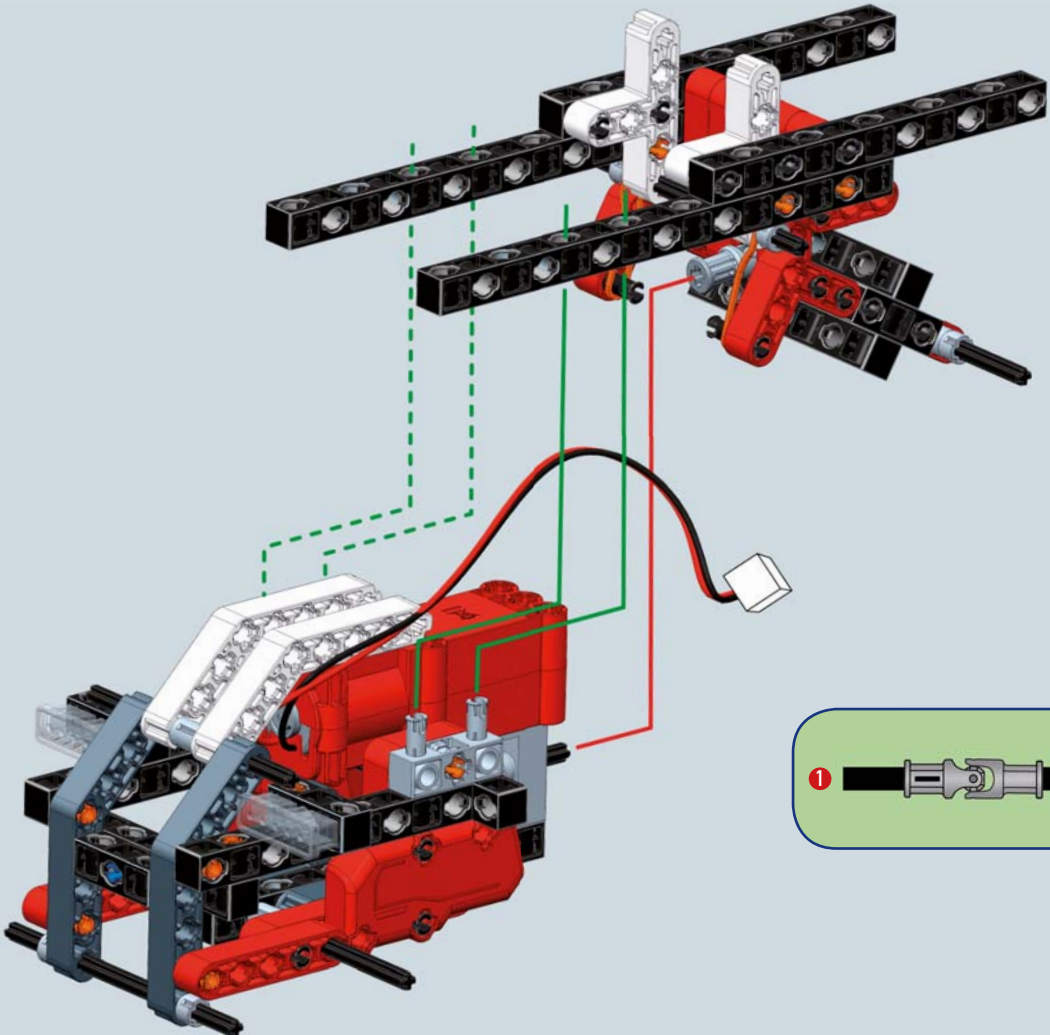
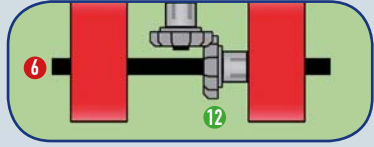
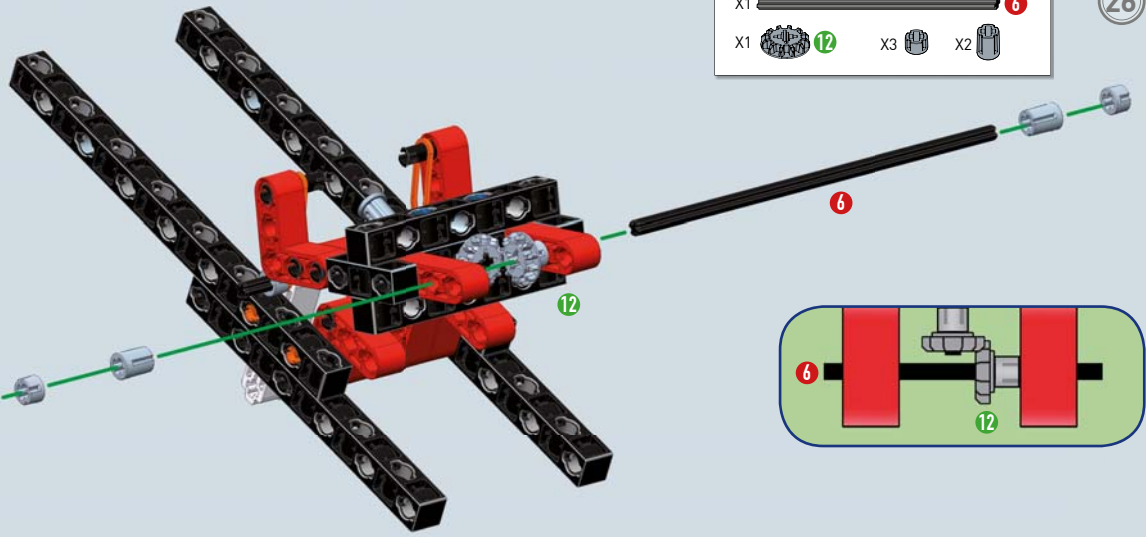







31

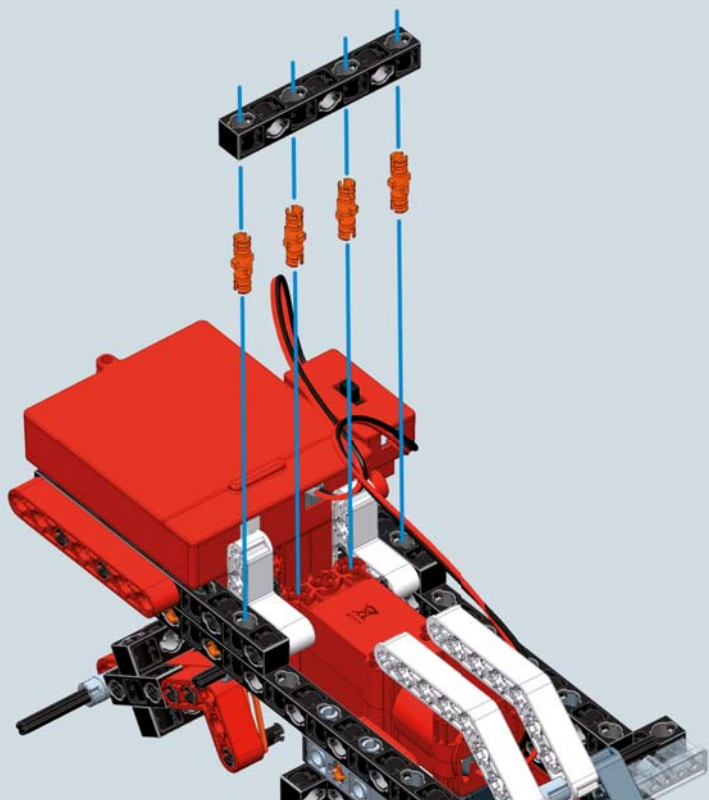

- X1
- X4

32

- X2
- X2
- X4
- X2

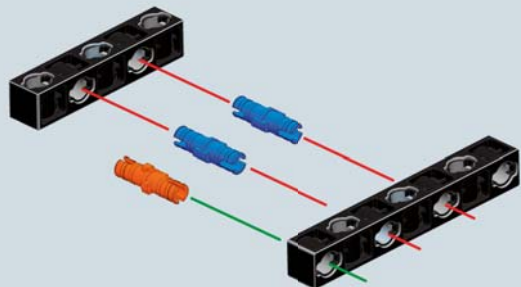
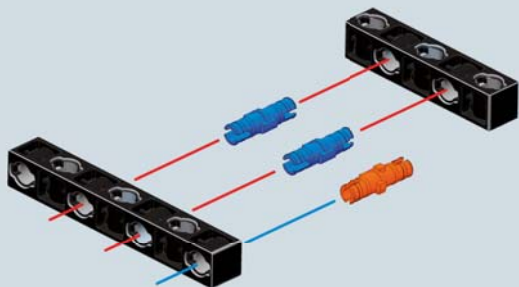

33

- X2
- X2

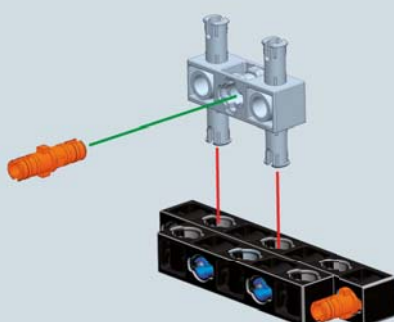
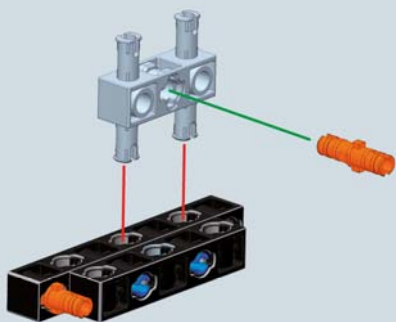

34

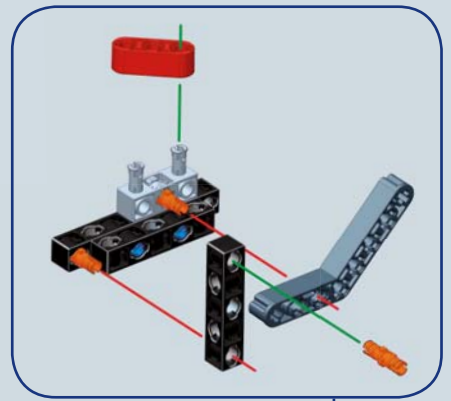
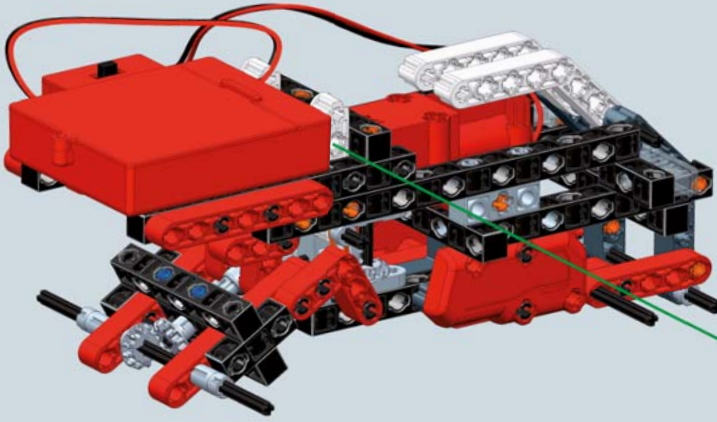
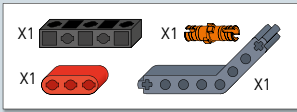

35

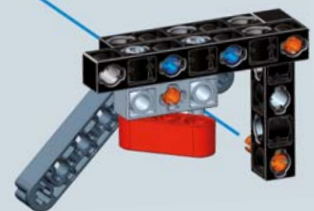
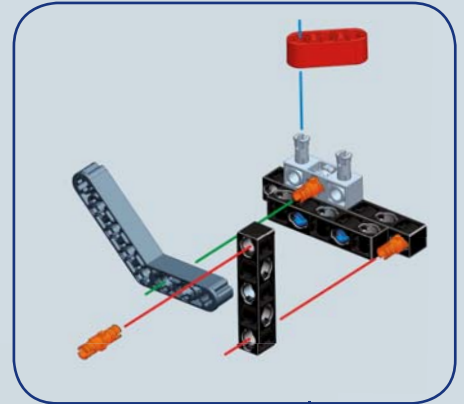
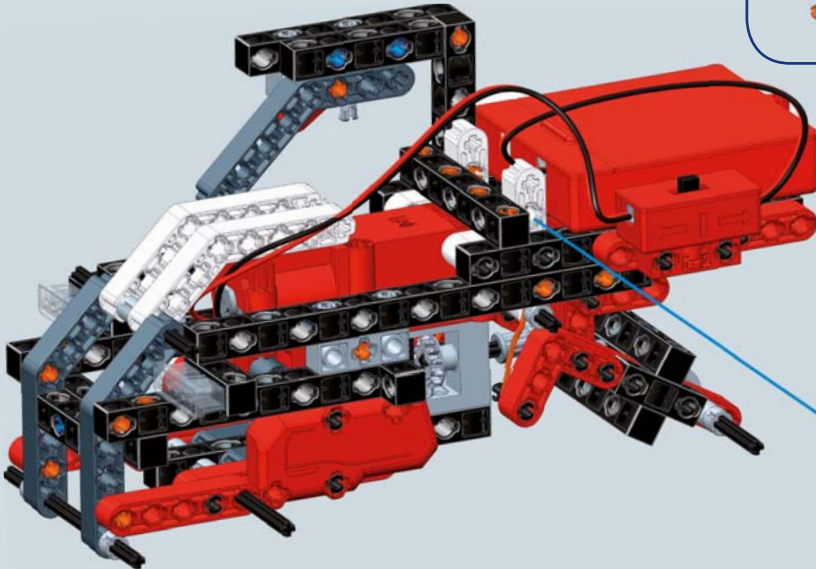
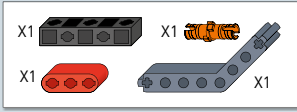

X1  5 X3  X2 

36

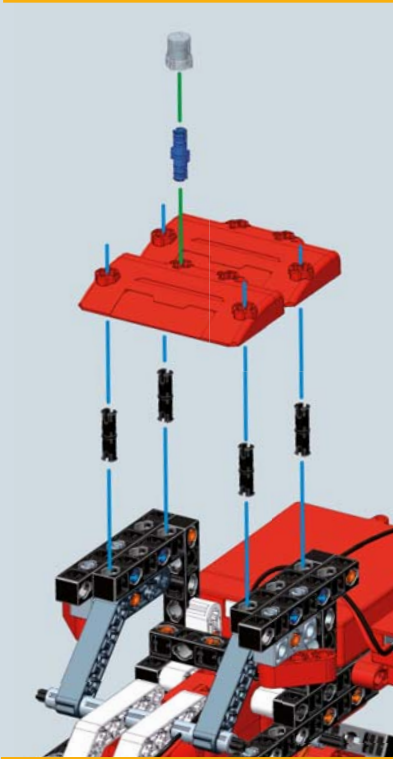
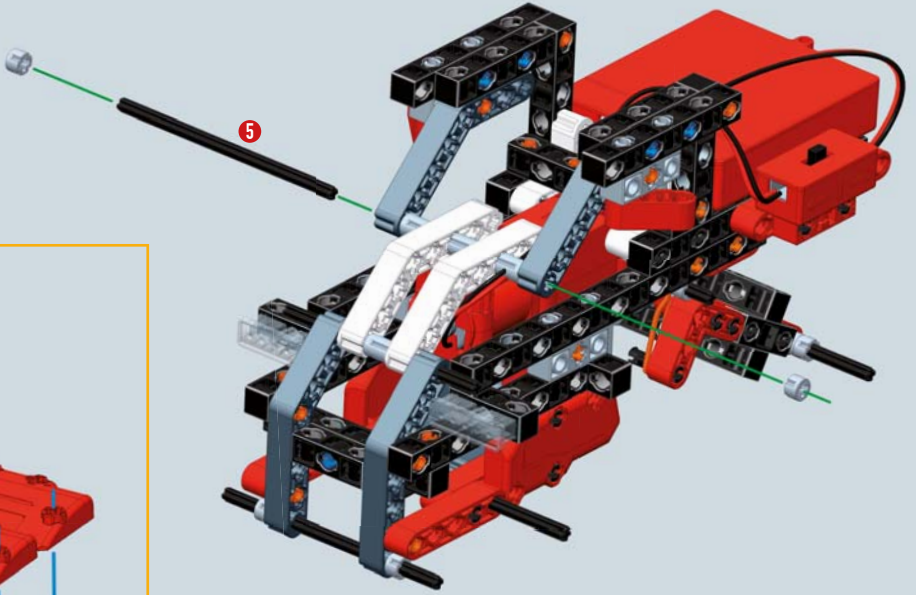

37

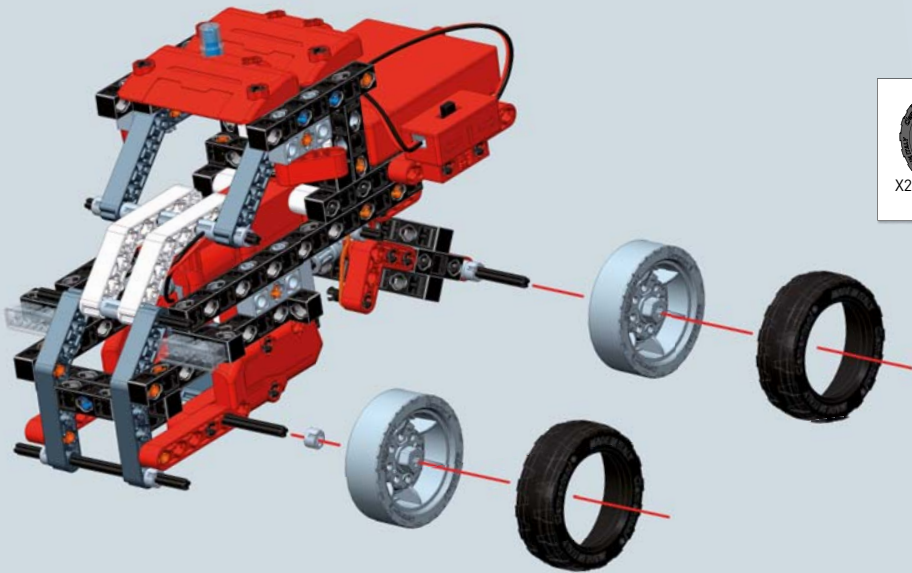
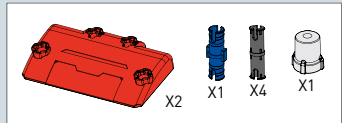

38

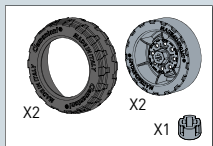

1:1  5



39

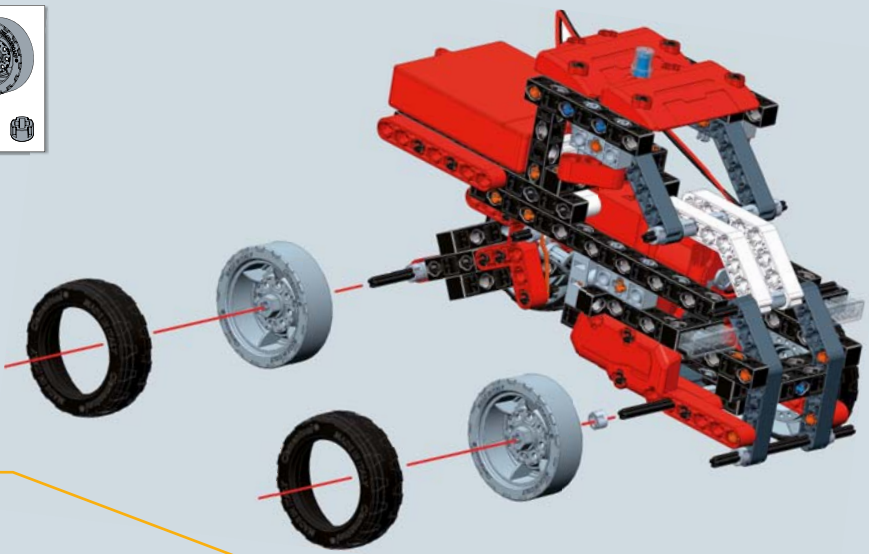
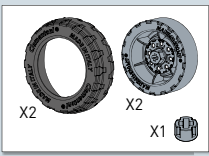

40

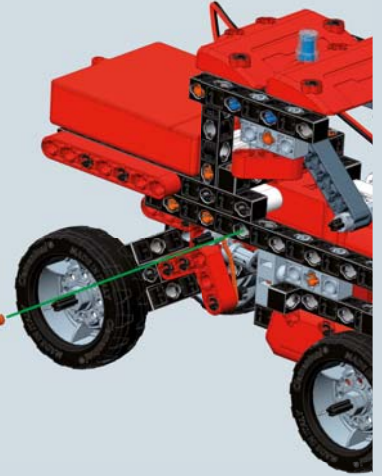
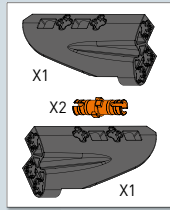

41

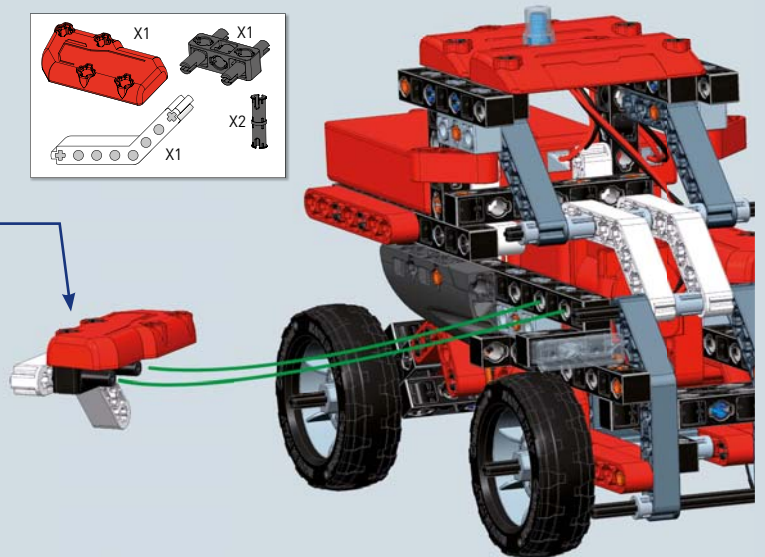
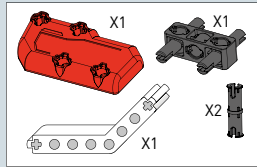
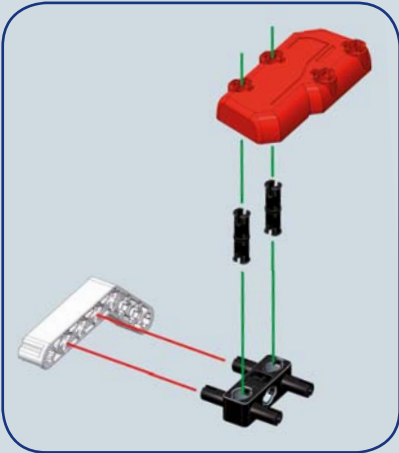



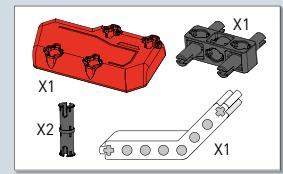
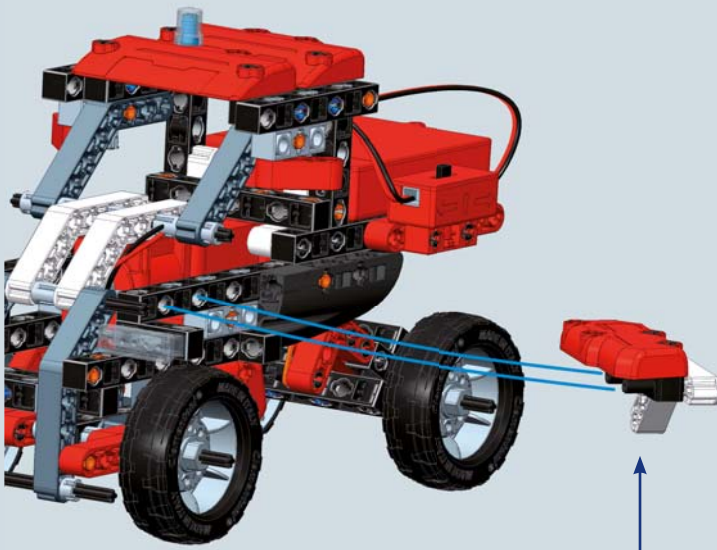

42

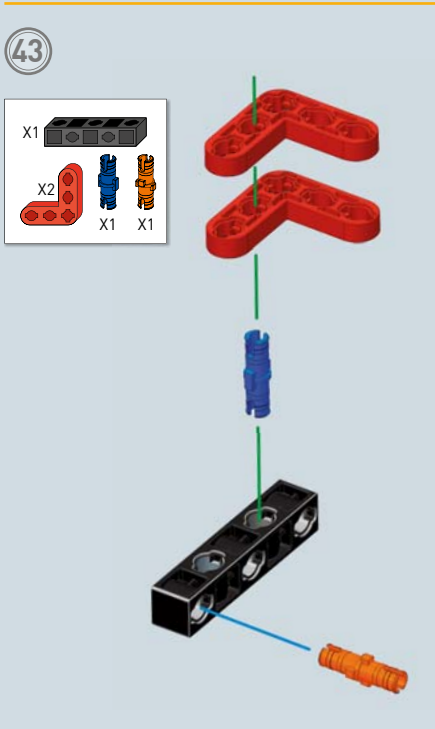
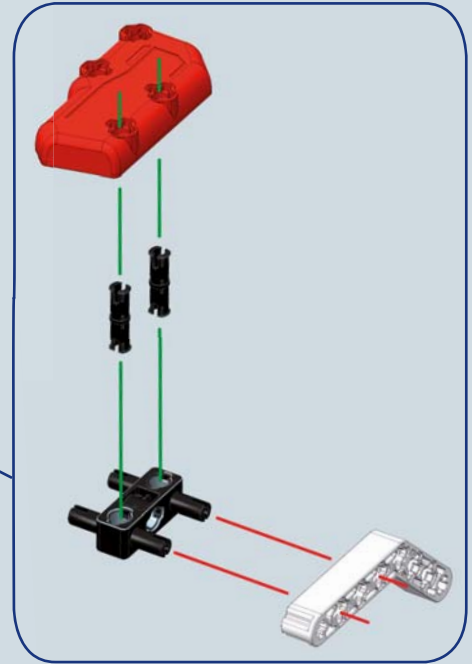

43

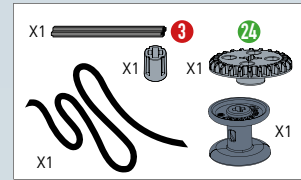
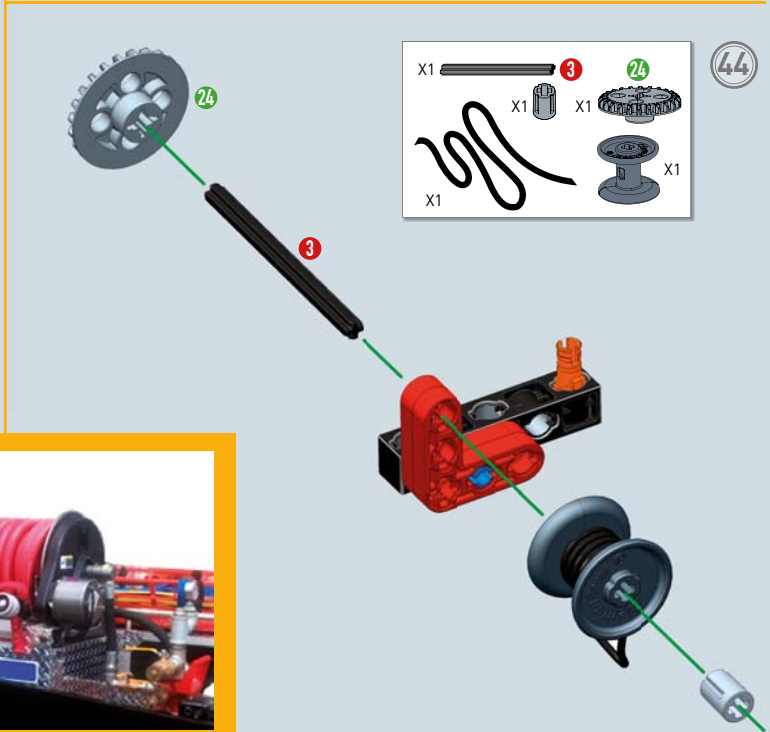
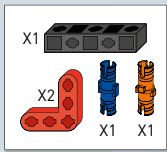

44

**Technische informatie en wetenswaardigheden**  
 Sommige voertuigen zijn uitgerust met brandbestrijdingsmiddelen: watertanken bevestigd op de achterkant van het voertuig met speciale waterslangen.



45

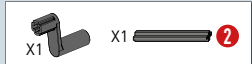
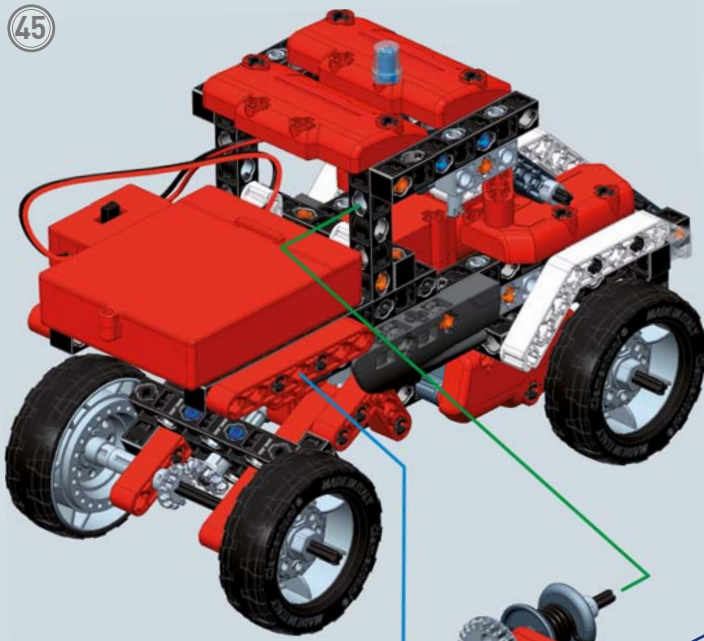

46

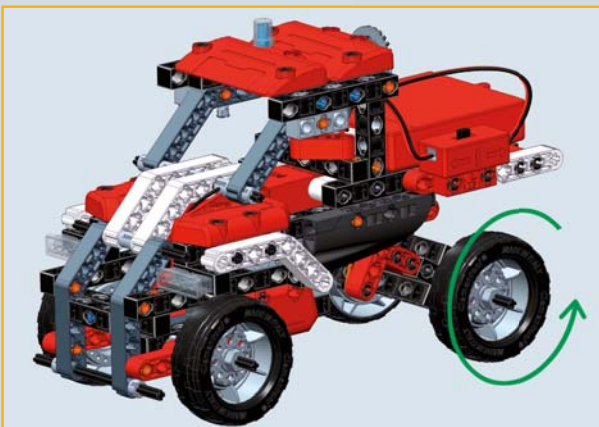
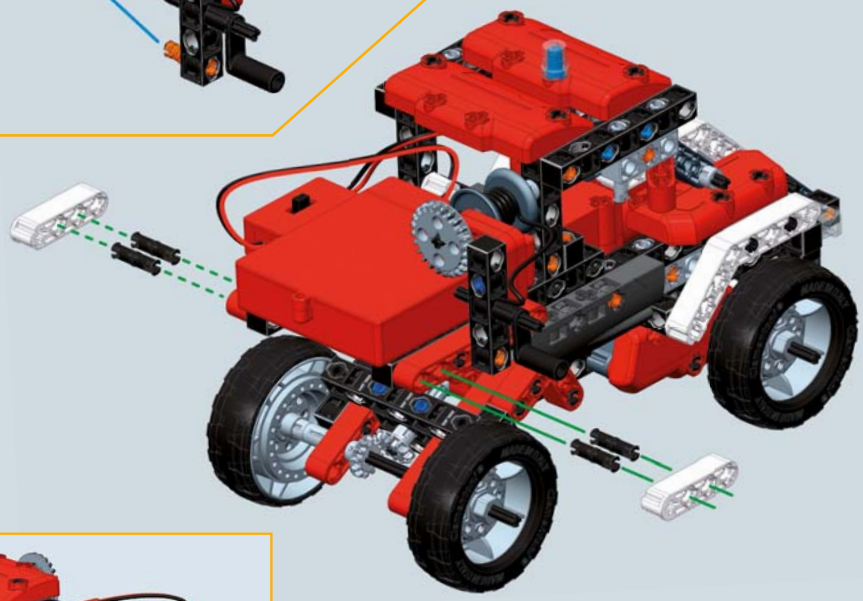
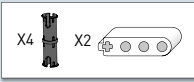

Gebruik de schakelaar om de rotatie van de achterwielen te starten.





De hovercraft is een voertuig dat op het water glijdt, dankzij een "luchtkussen" dat wordt gevormd onder de soepele rokken. Zijn propellers liggen niet ondergedompeld in het water, maar bevinden zich aan boord, voor meer stuwkracht en om het voertuig sneller te laten draaien.

Hovercrafts worden in heel de wereld vaak als reddingsvoertuig gebruikt bij de kustwacht, brandweer, nood- en spoedhulp. De speciale technische eigenschappen van dit voertuig zorgen ervoor dat hij snel en tegelijkertijd makkelijk te besturen is, en dat hij plaatsen kan bereiken die moeilijk toegankelijk zijn voor normale vaartuigen.

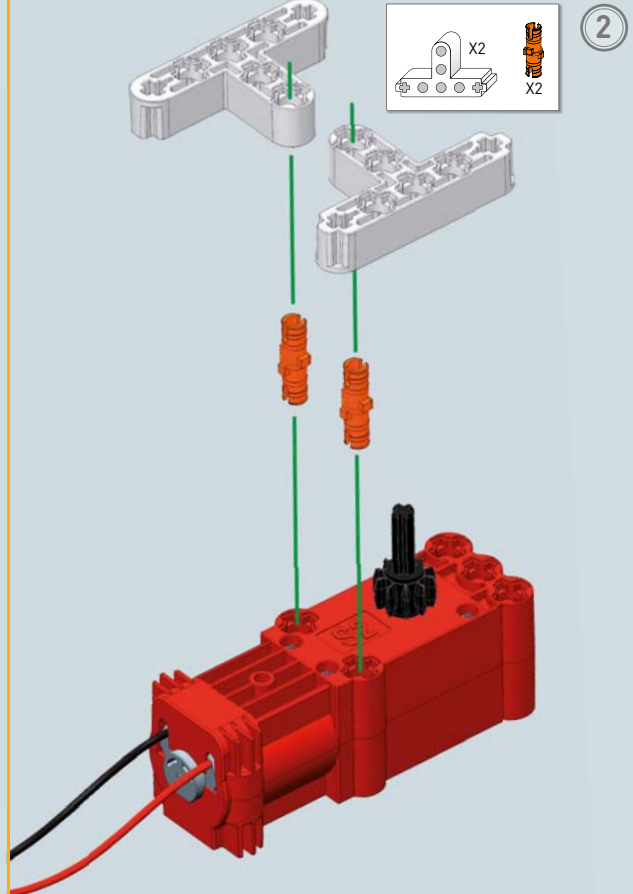
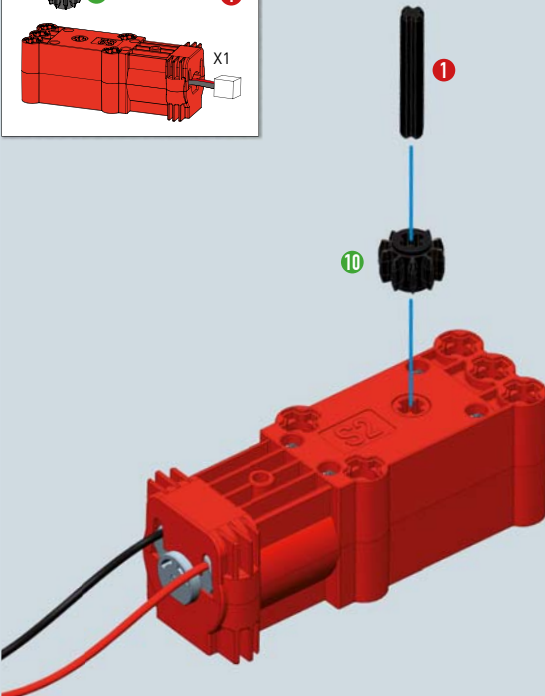
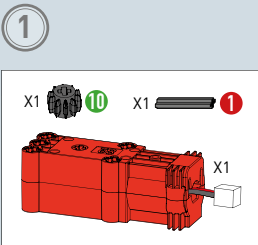







Sluit de kabel van de schakelaar  
aan op het batterijvak

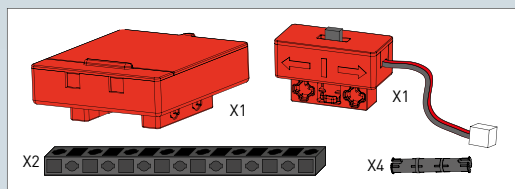
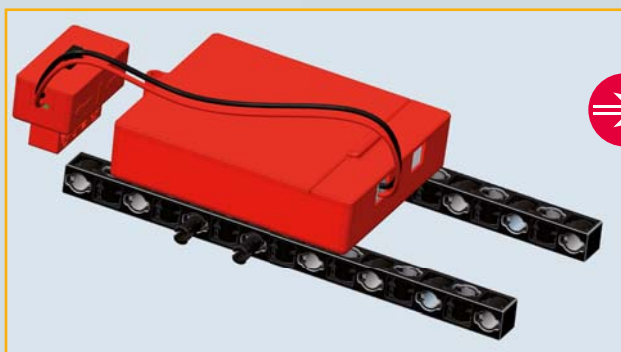
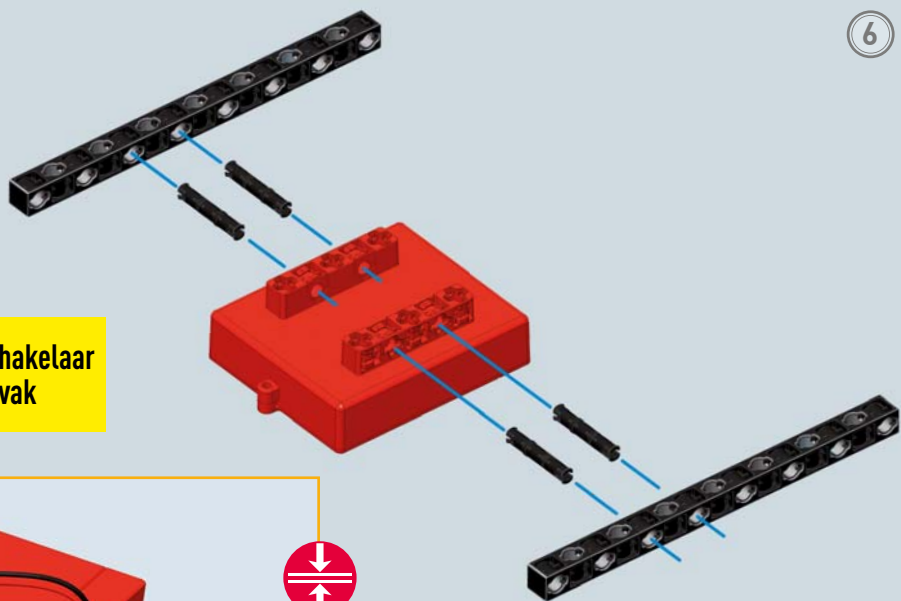

Sluit de kabel van de motor  
aan op de schakelaar

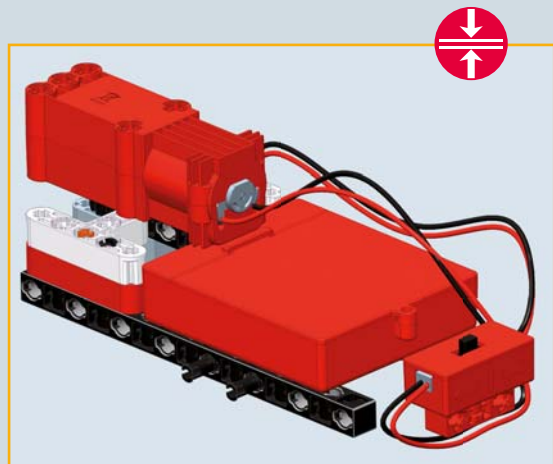
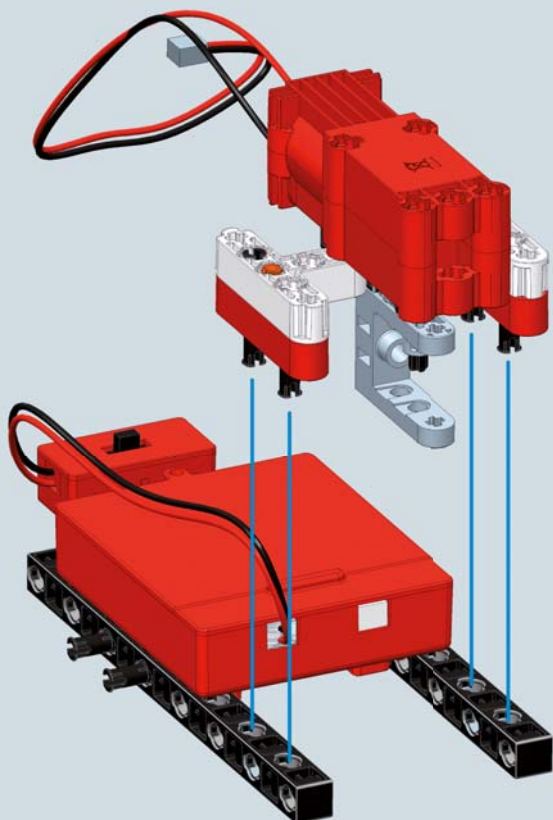

8

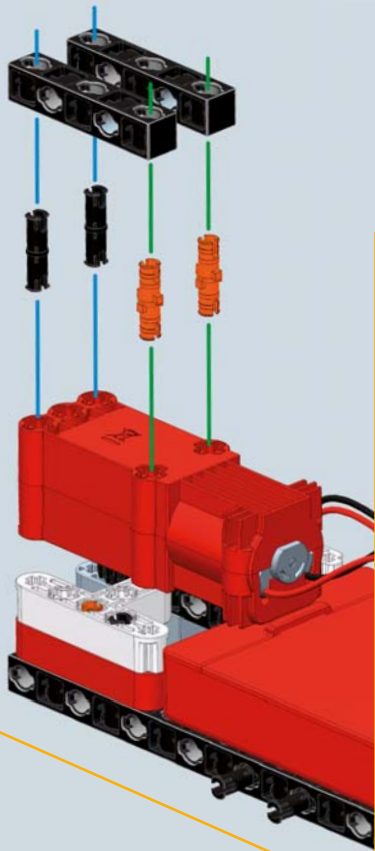

- X2
- X2
- X2

9

- X1 5
- X1 26
- X2
- X1 18



10

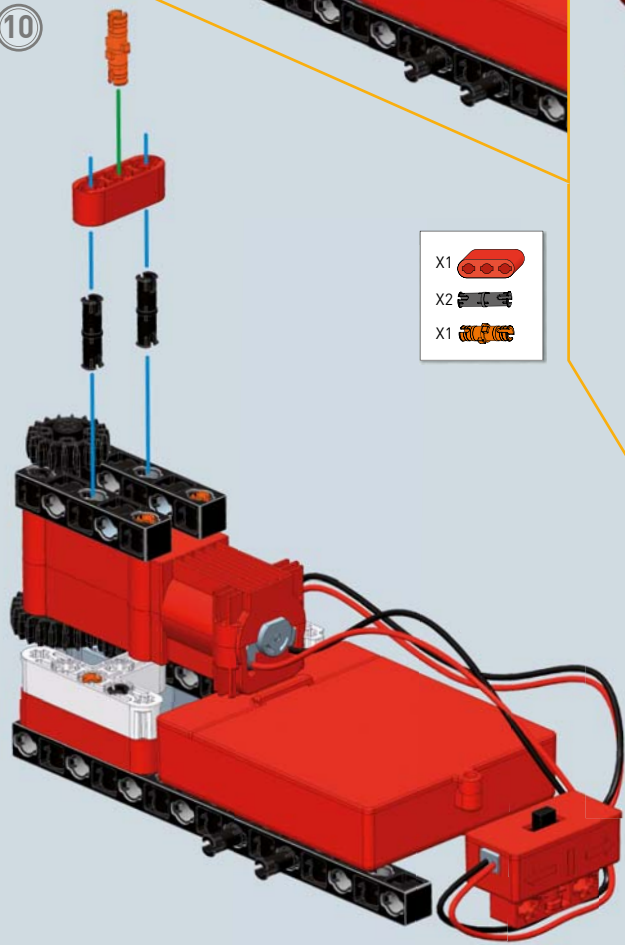

- X1
- X2
- X1

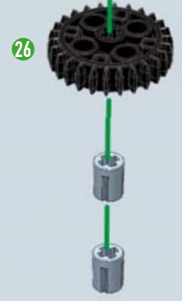
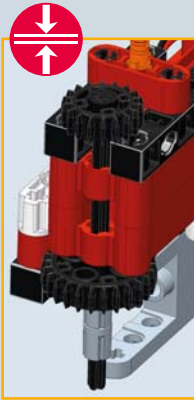
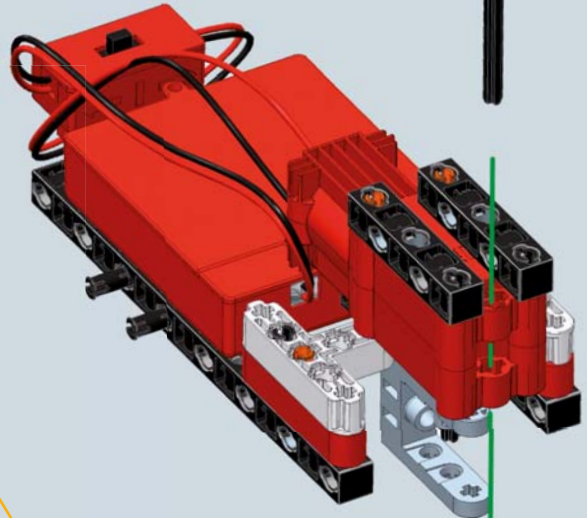

11

X2			X4
X2			



12

X2		4		18
X1		3		X1
		X1		X3

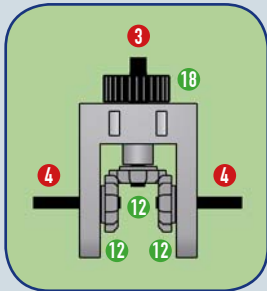
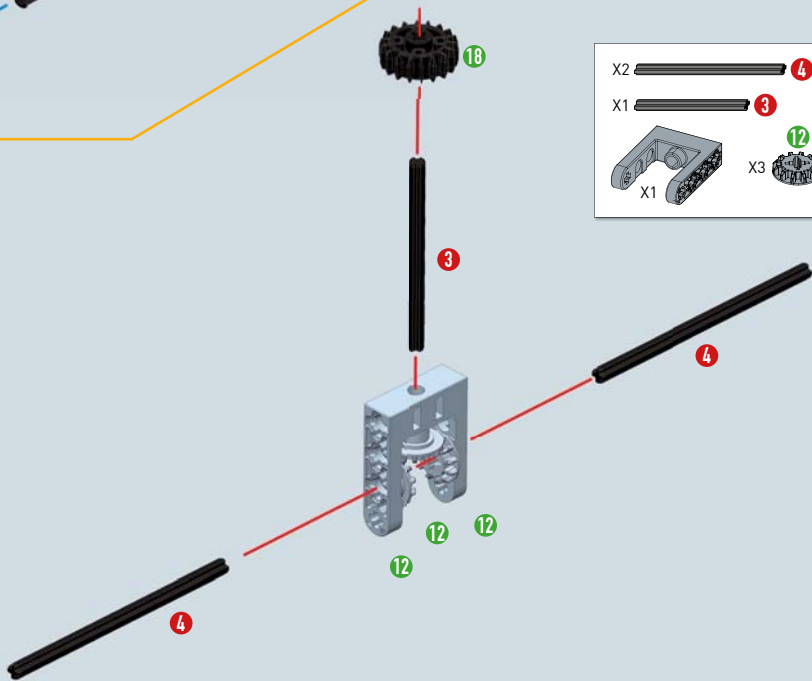

13

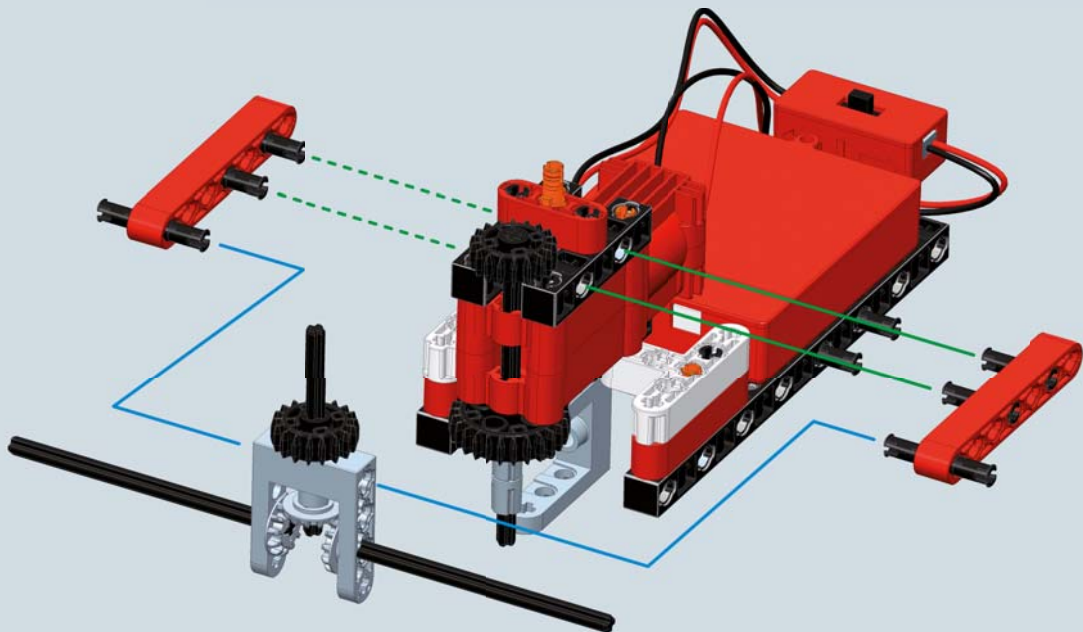

1:1

1:1

14

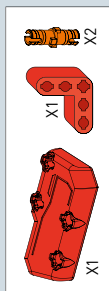
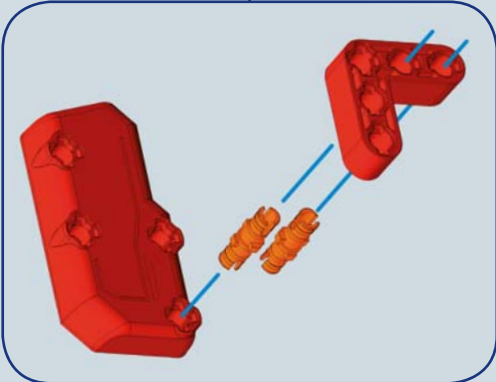
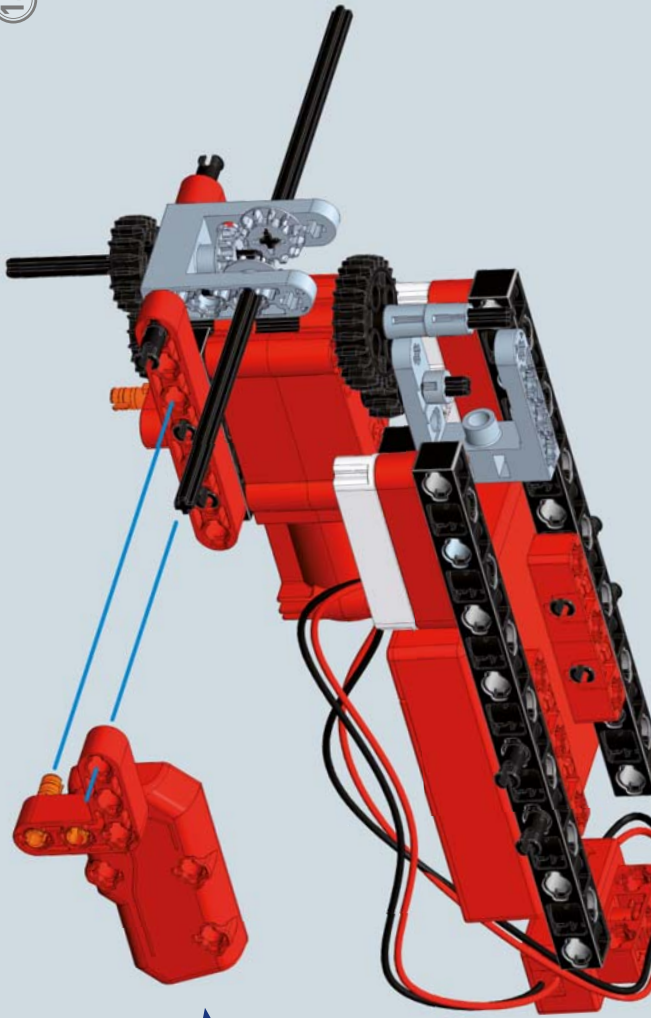

15

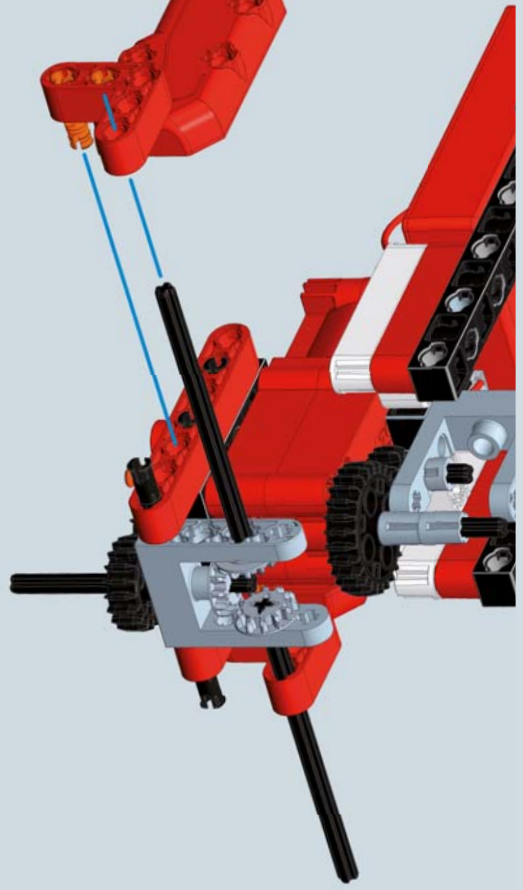
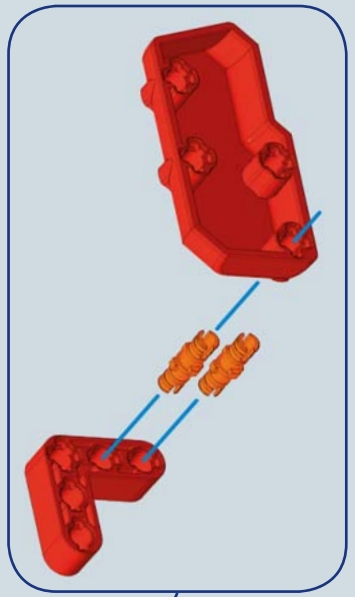
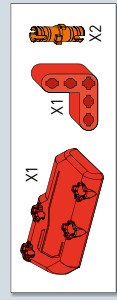



16

X1		X1		X1	
X1					
X1					

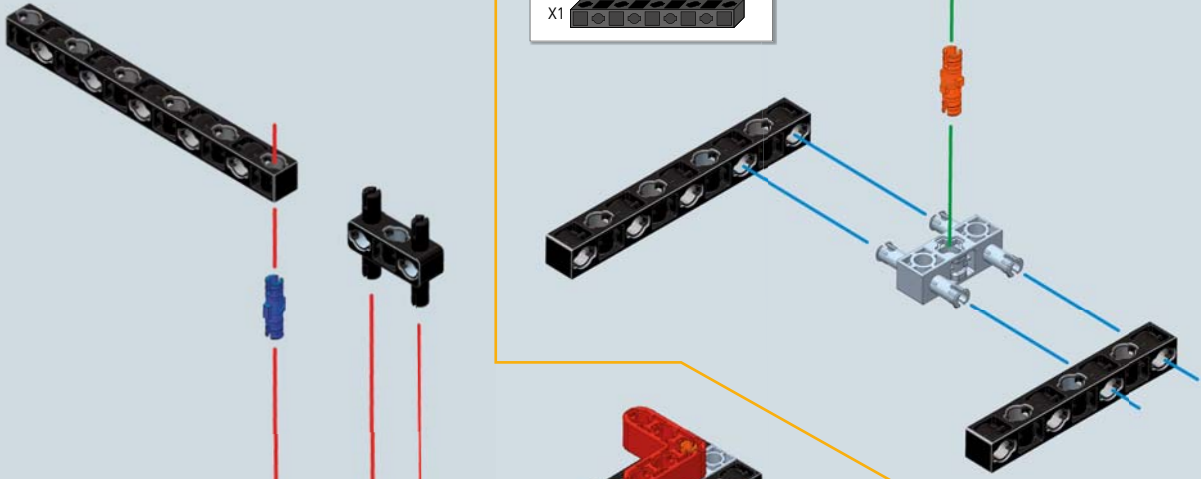

17

X2		X1	
X1			
X1			

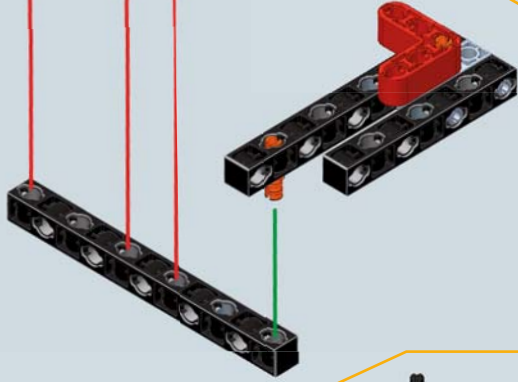

18

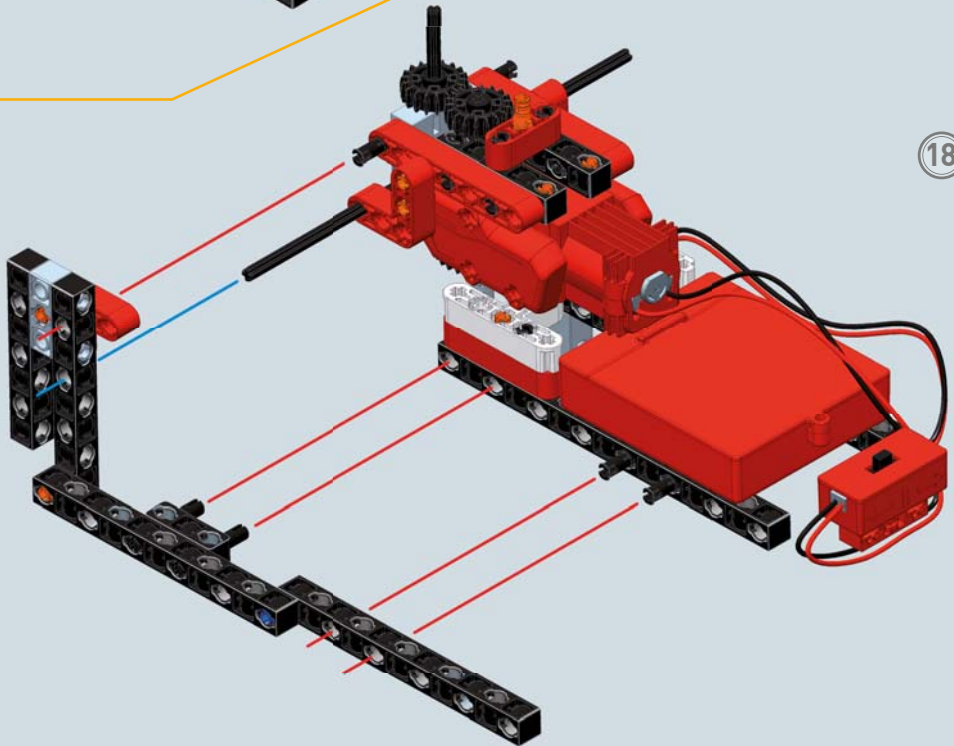



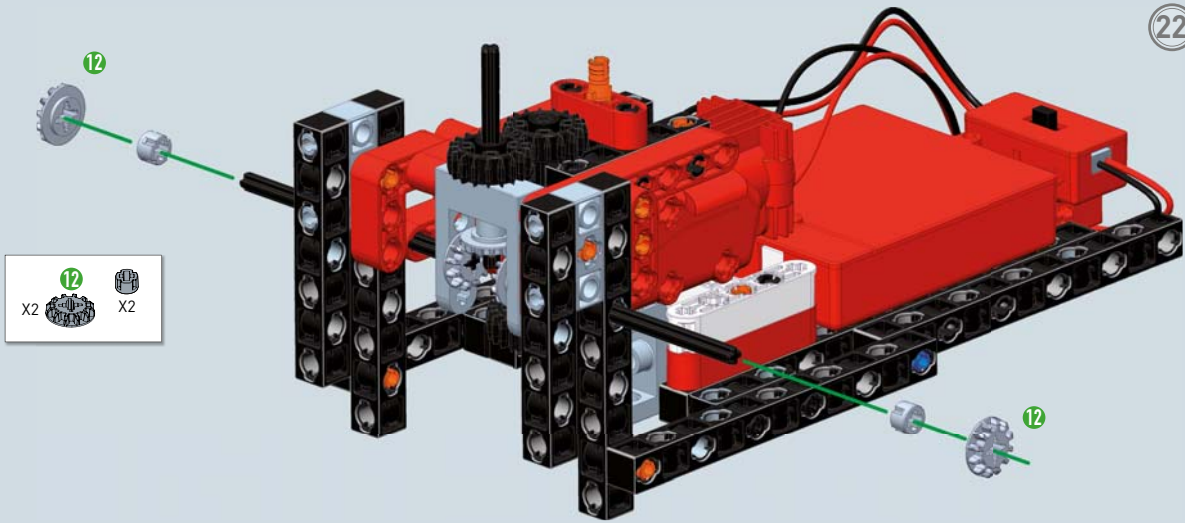

12 X2

12 X2

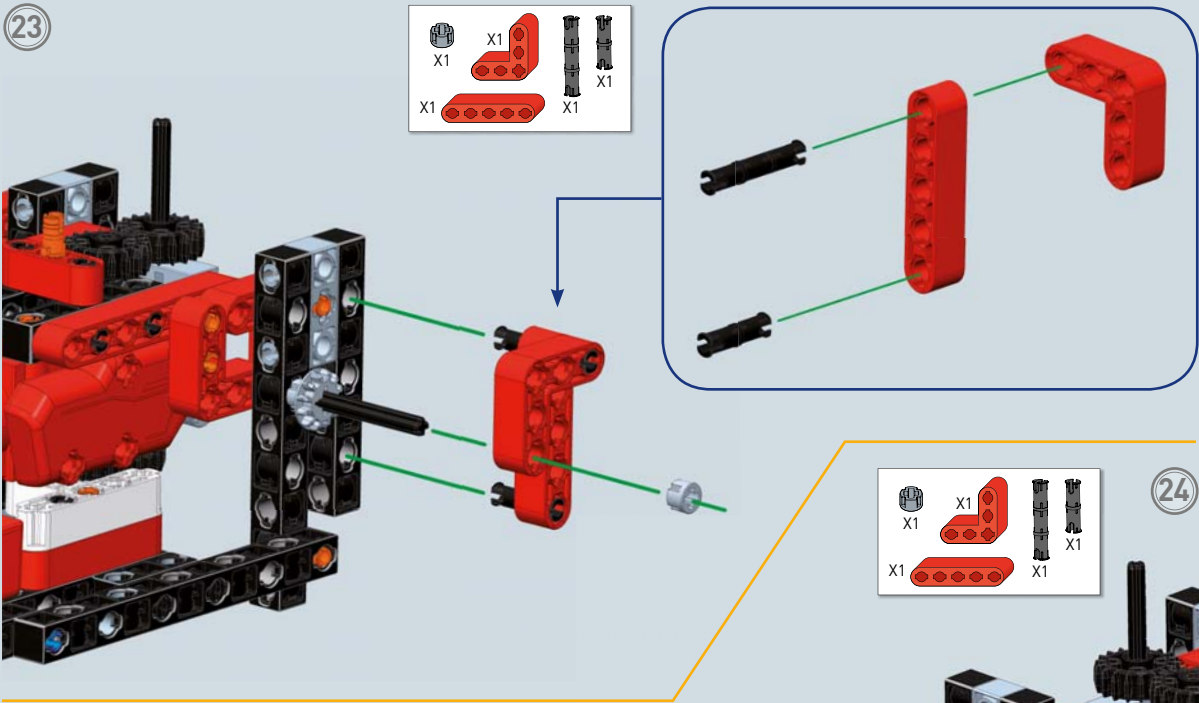

X1 X1

X1 X1

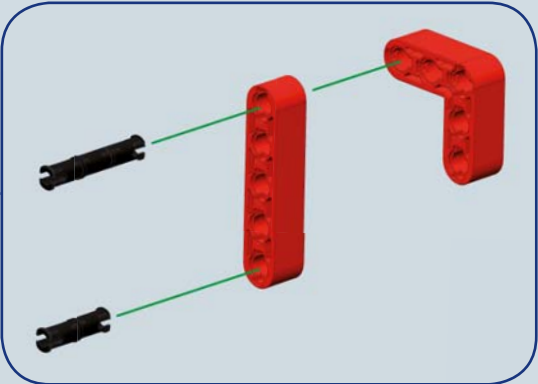





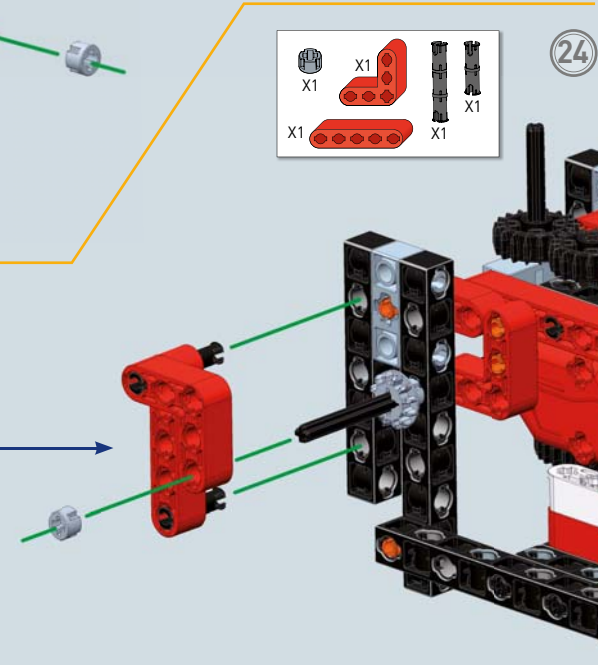
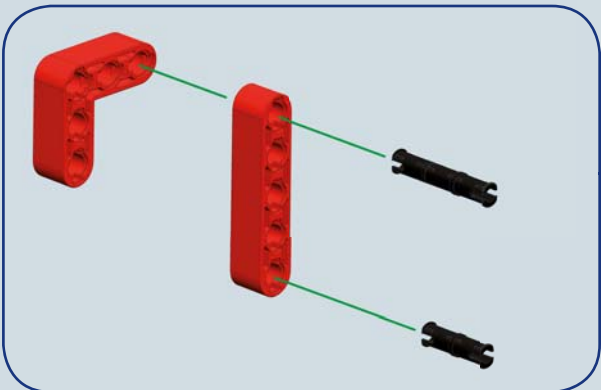
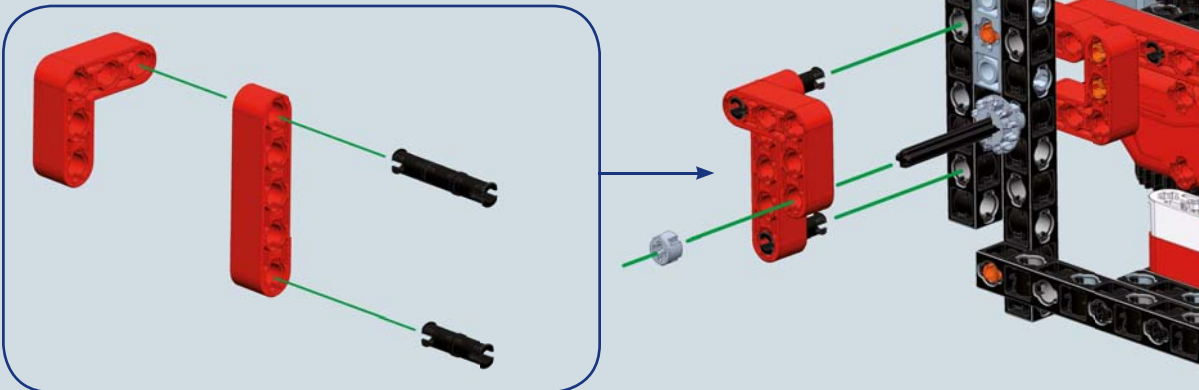

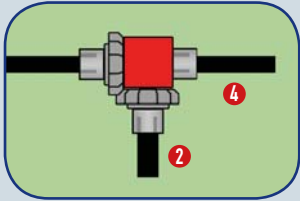
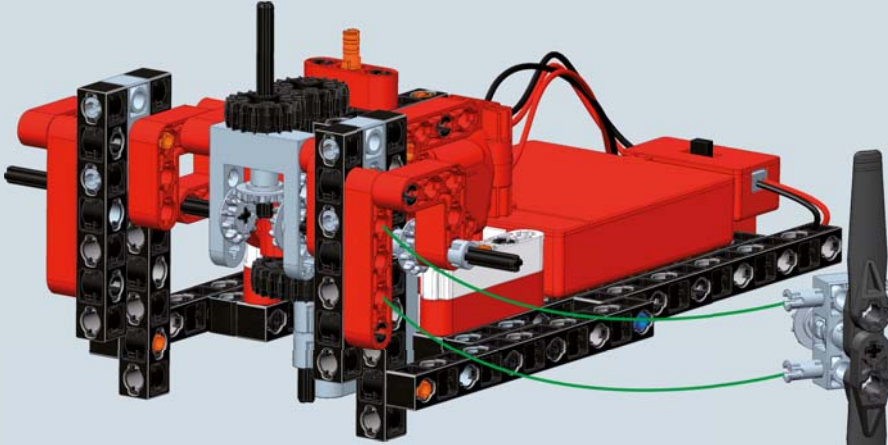
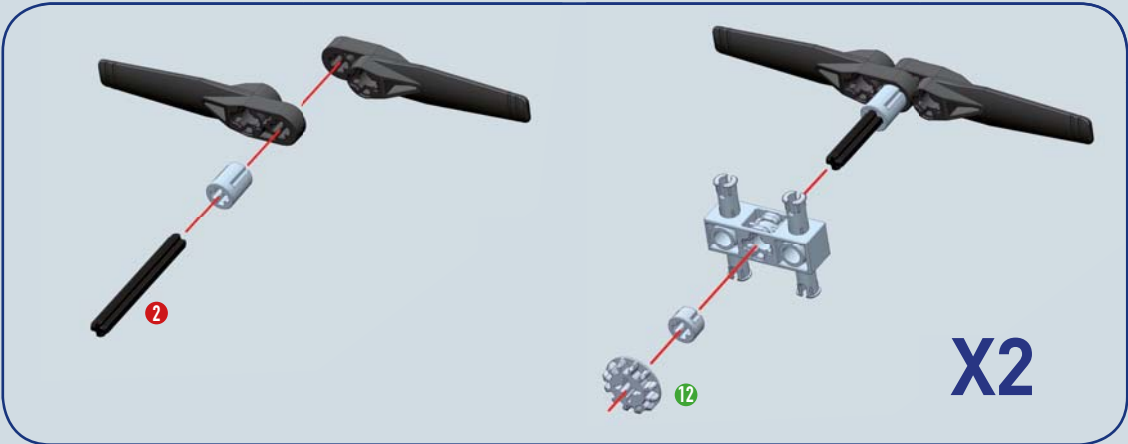
X1 X1

X1 X1





- X2  2
- X4 
- X2 
- X2  12
- X2 
- X2 

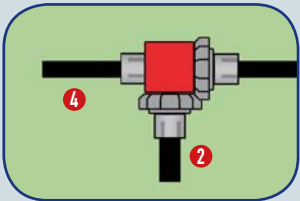
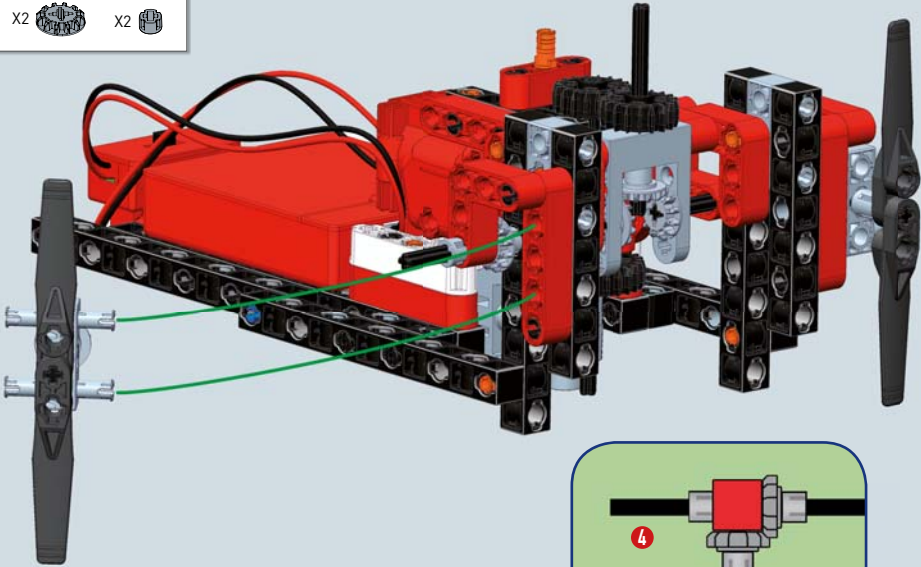



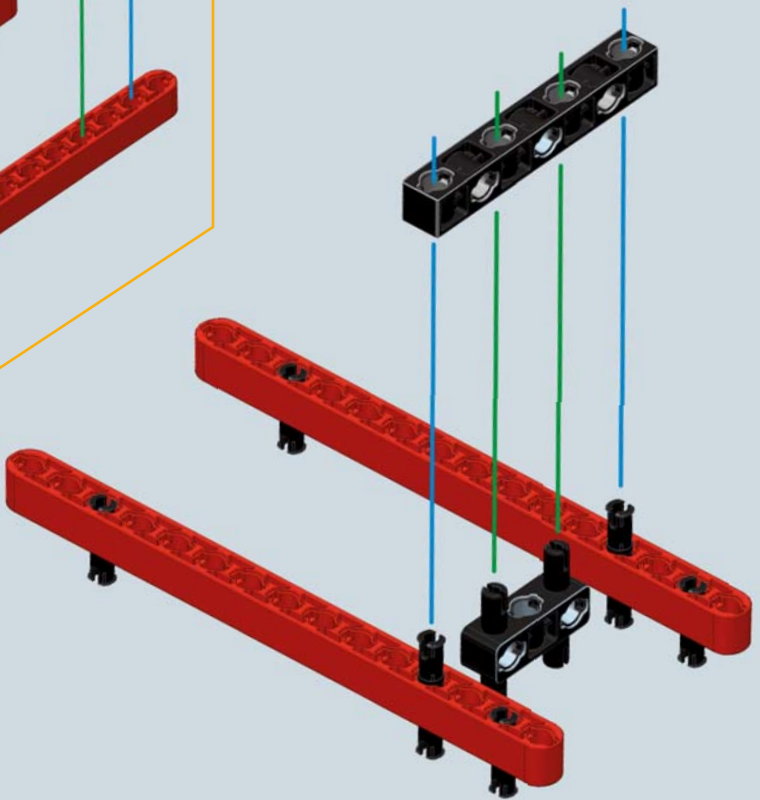
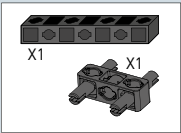
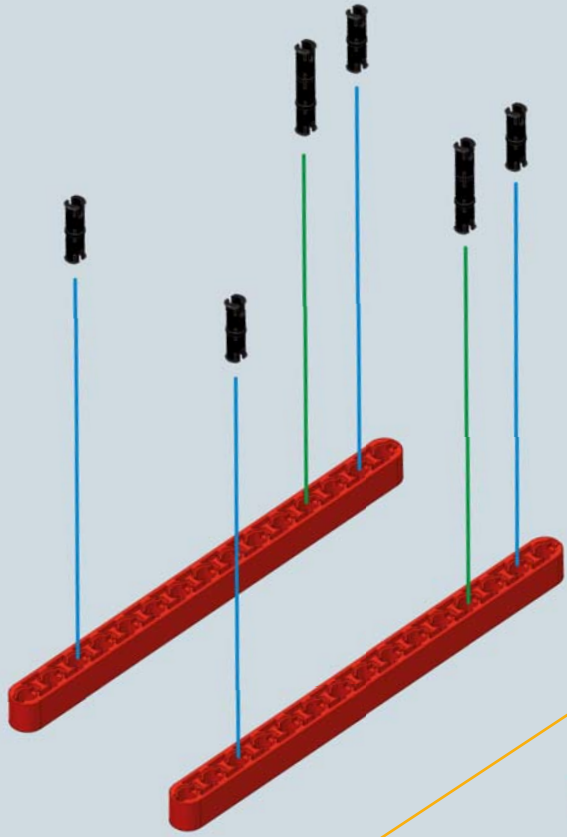
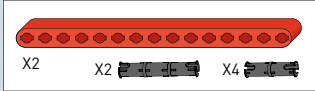
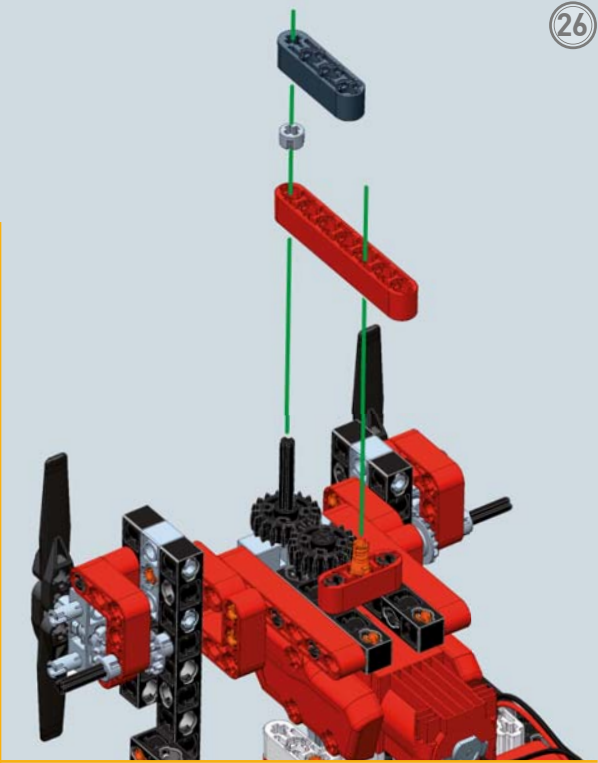
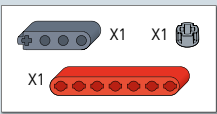

29

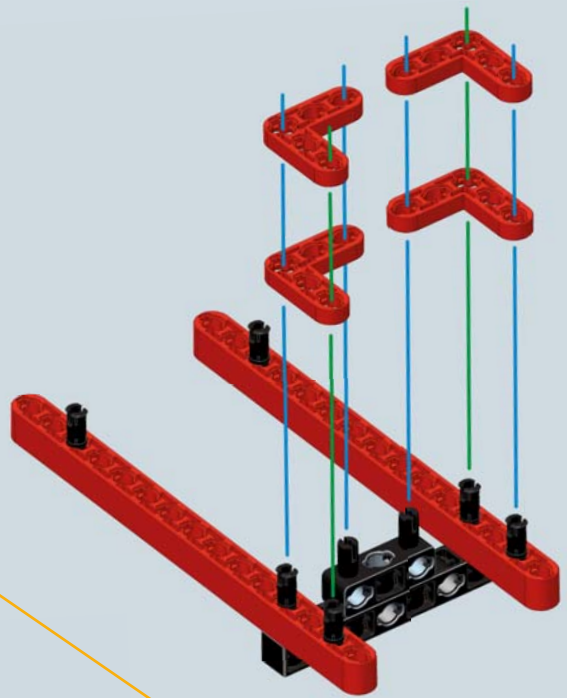

30

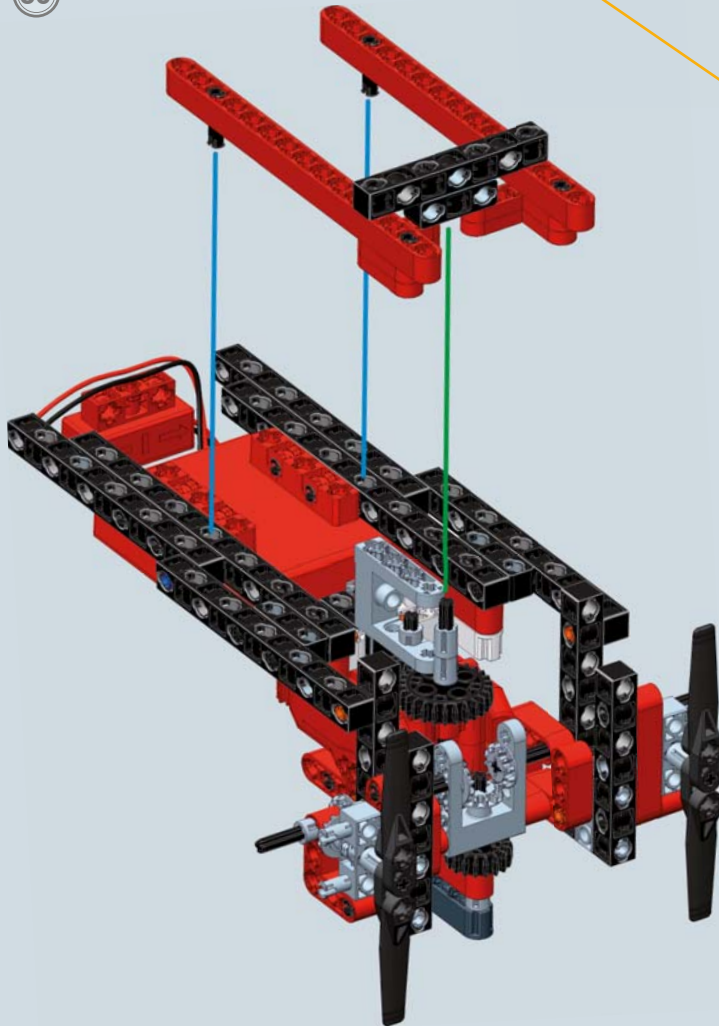

#### Technische informatie en wetenswaardigheden

De propellers van de hovercraft liggen niet in het water: de stuwkracht wordt dus gegenereerd door contact met de lucht. Deze stuwende propellers van het aeronautische type worden achteraan het voertuig gemonteerd en hebben zeer fijne bladen die zeer snel draaien.

31

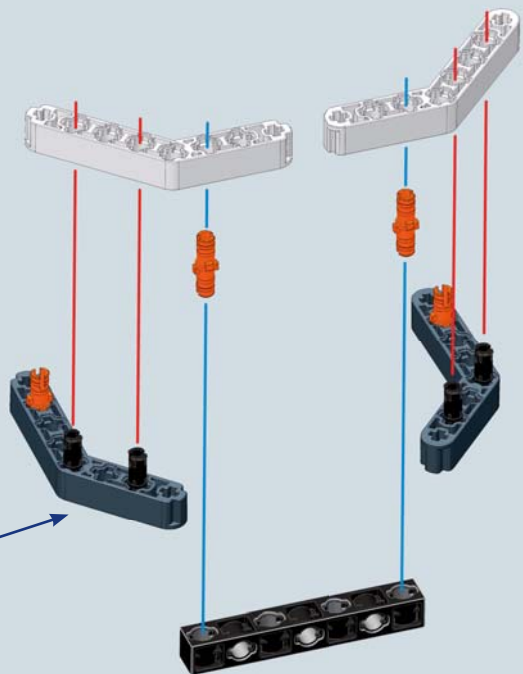
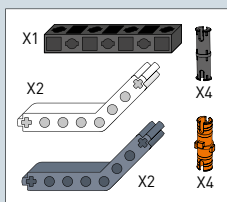
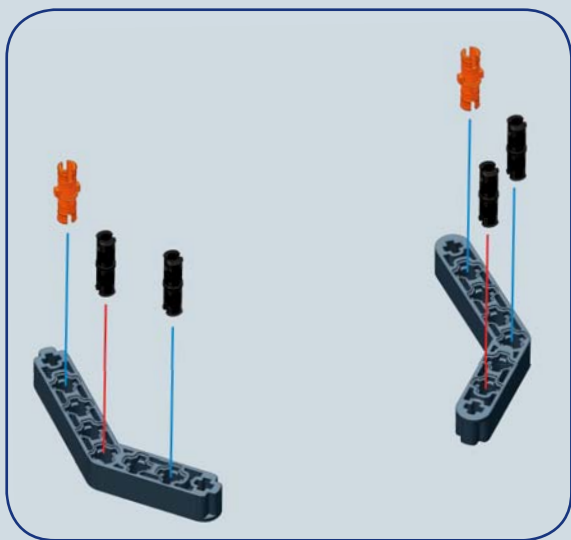

32

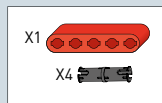
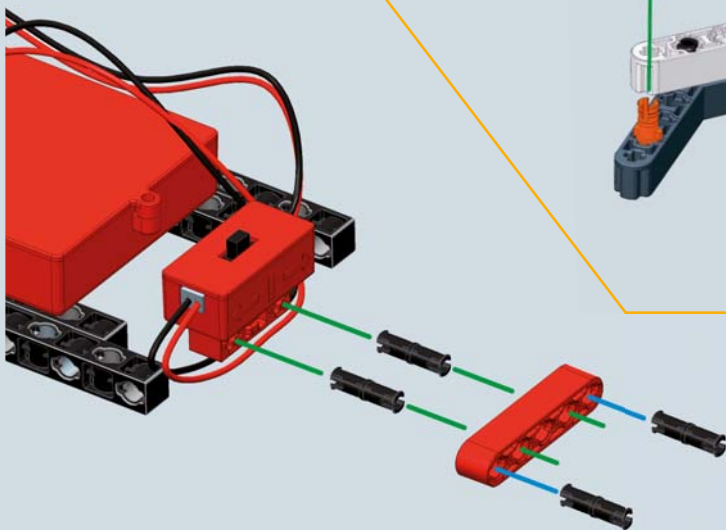
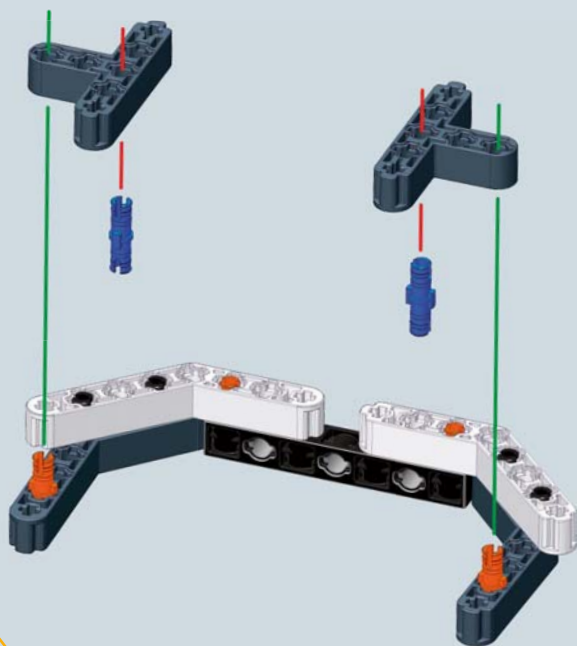
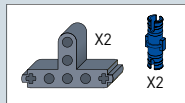

33

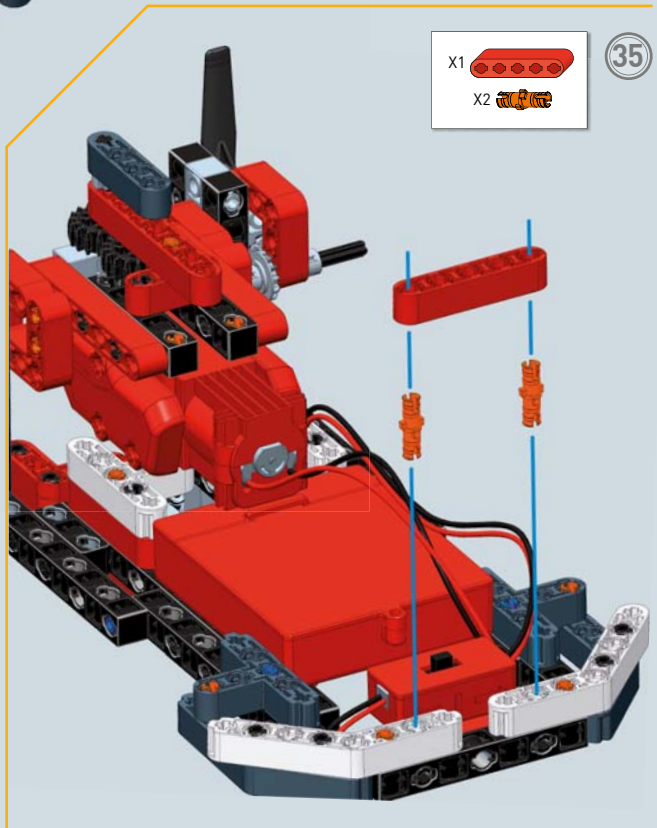
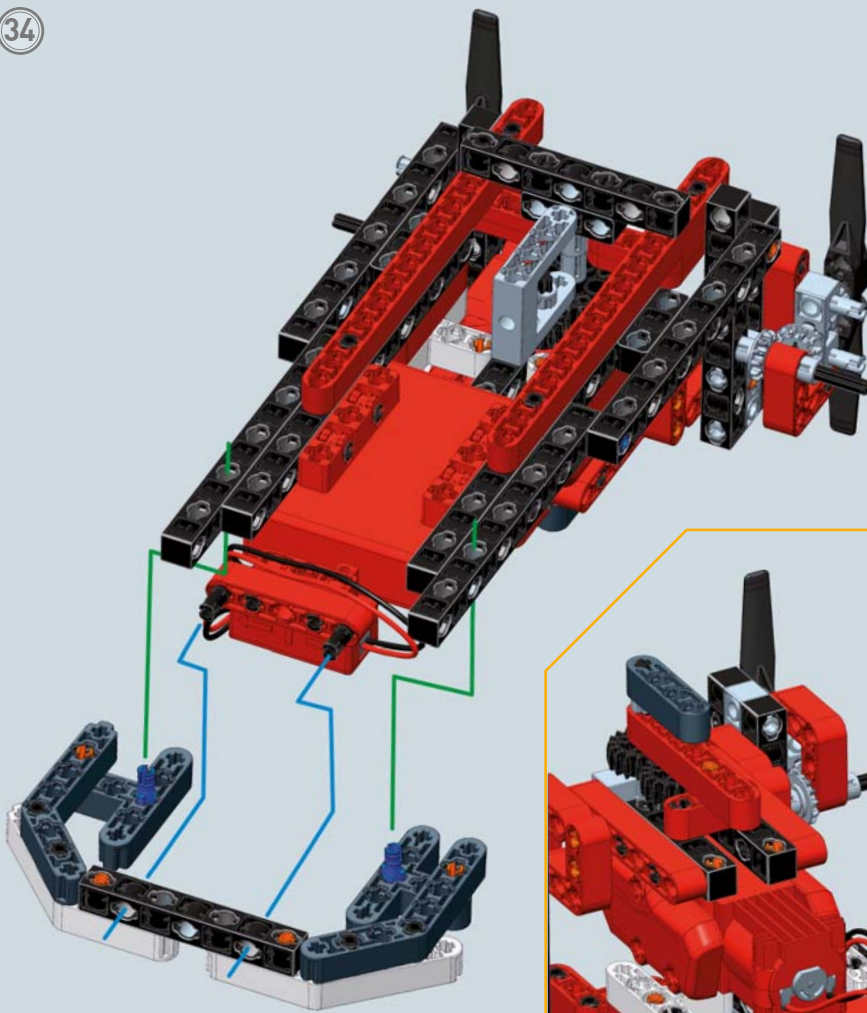

- X1
- X2

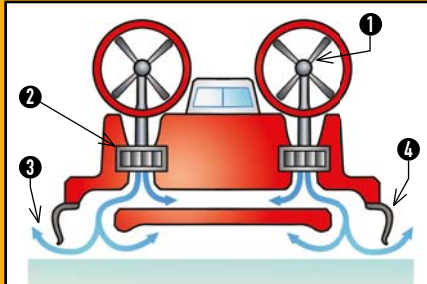

- ① - Propellers
- ② - Motor
- ③ - Lucht
- ④ - Soepele rokkens

**Technische informatie en wetenswaardigheden**

De door de motor geproduceerde lucht wordt gestuwd naar de rokkens en vormt zo een permanente luchtuitloop naar het oppervlak. Dit "vlottend" effect zorgt ervoor dat de hovercraft zeer licht wordt en op het water kan glijden. Een stel propellers wordt gebruikt om het vaartuig aan te drijven en te laten draaien, maar is ook nuttig om de snelheid te verminderen, wanneer het vaartuig moet vertragen.





### Technische informatie en wetenswaardigheden 3

Dankzij het luchtkussen kan de hovercraft zich vlot verplaatsen op modderige of moerassige terreinen, net zoals op een compacte ondergrond. De soepele rokken voorkomen dat het vaartuig beschadigd wordt.

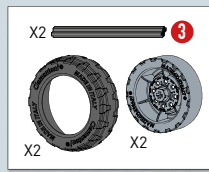

36

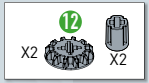
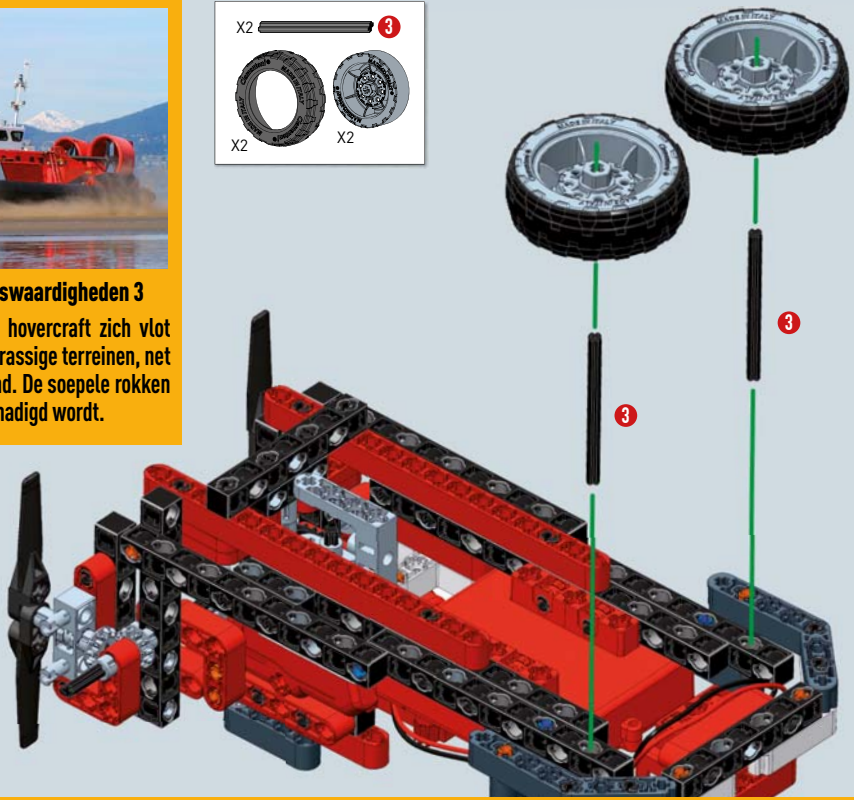

37

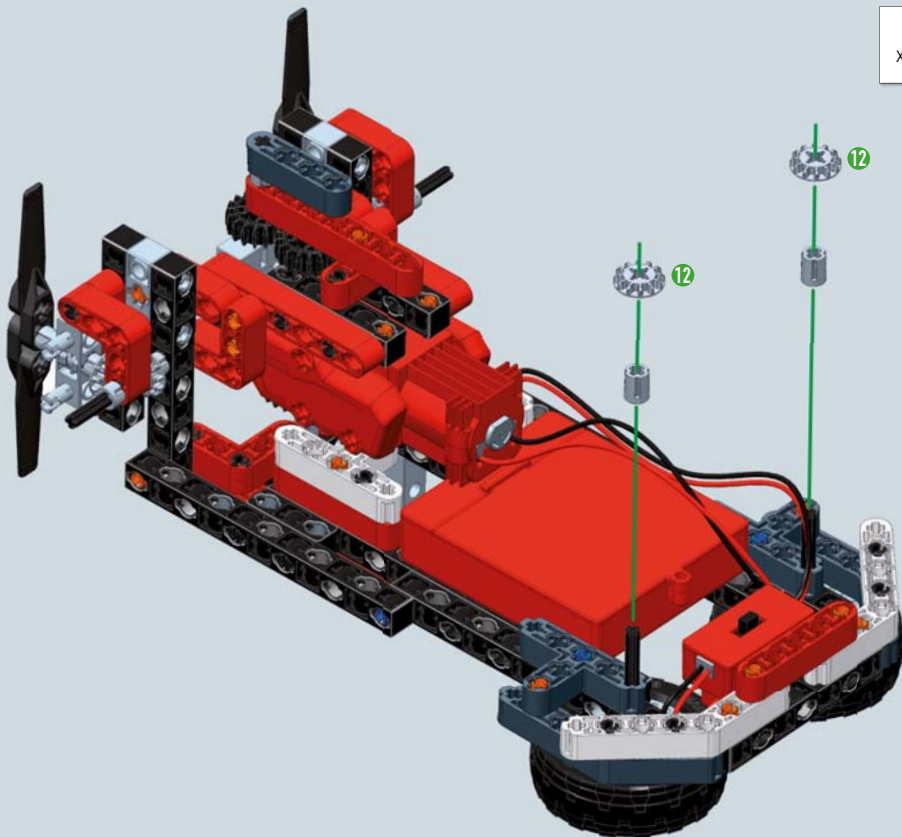

38

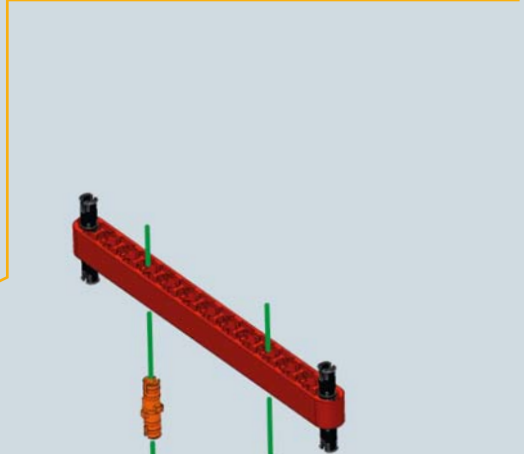
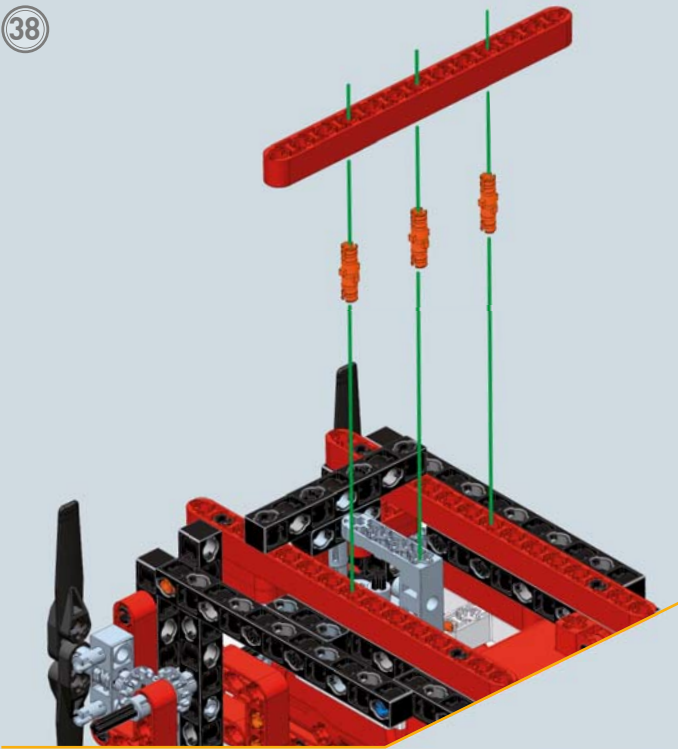



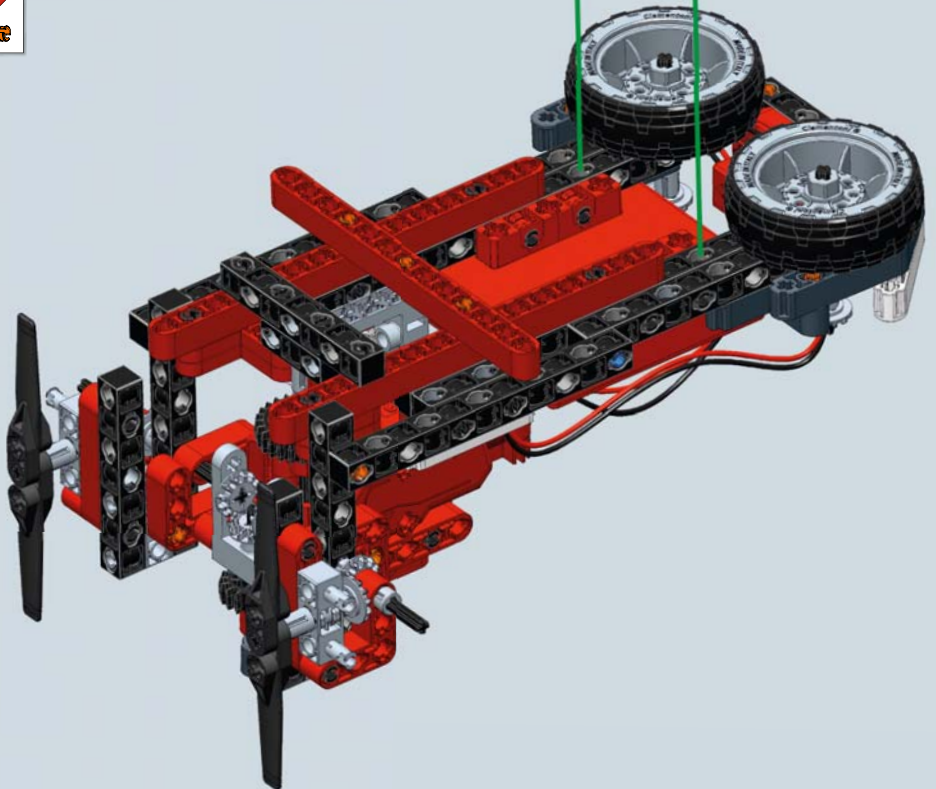
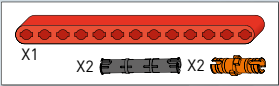

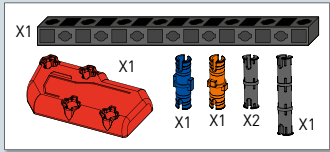
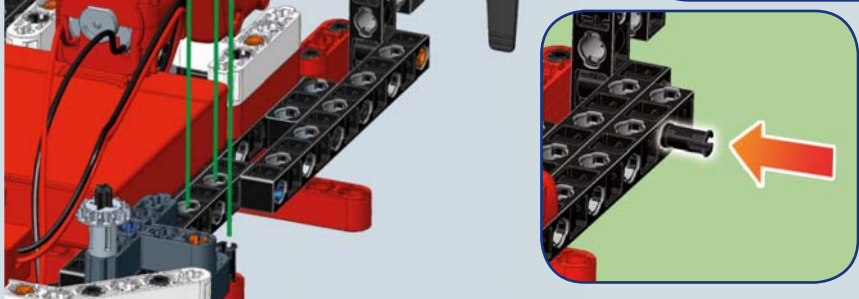
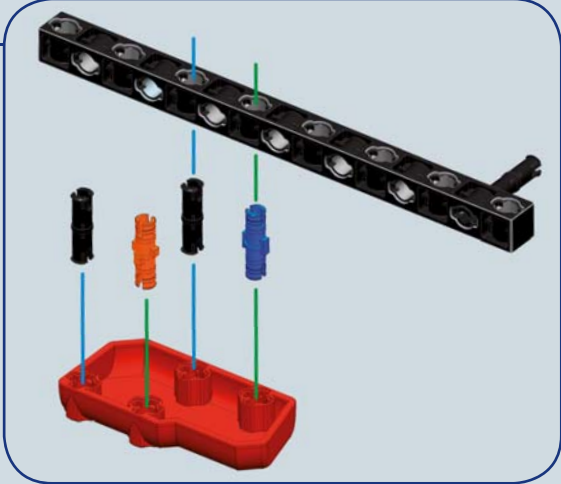
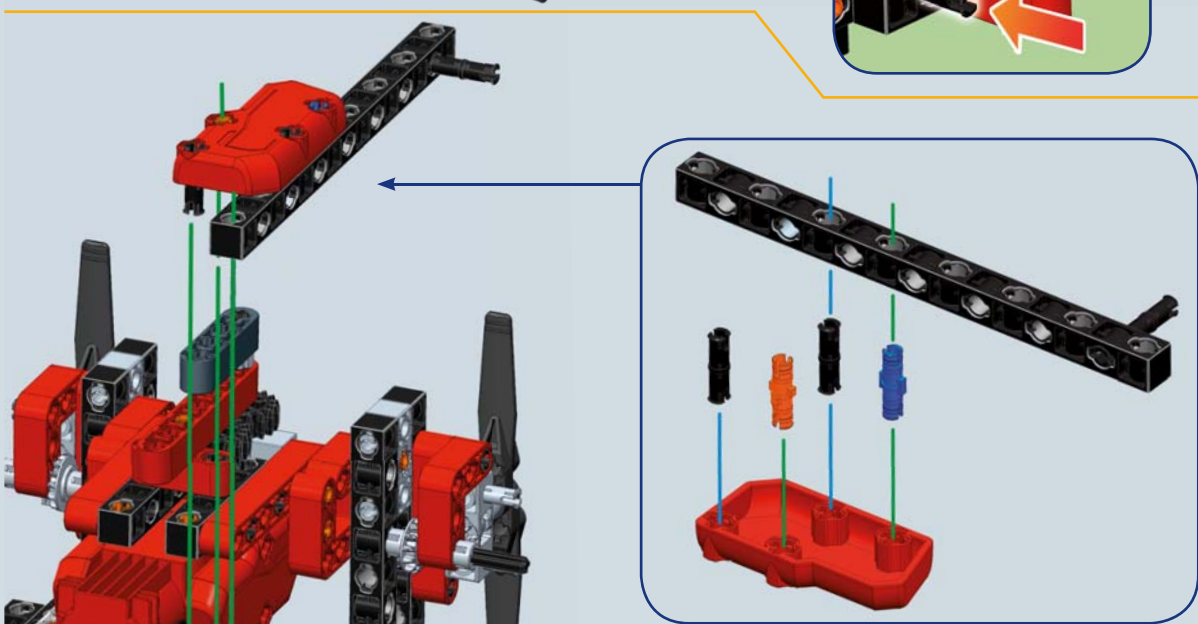
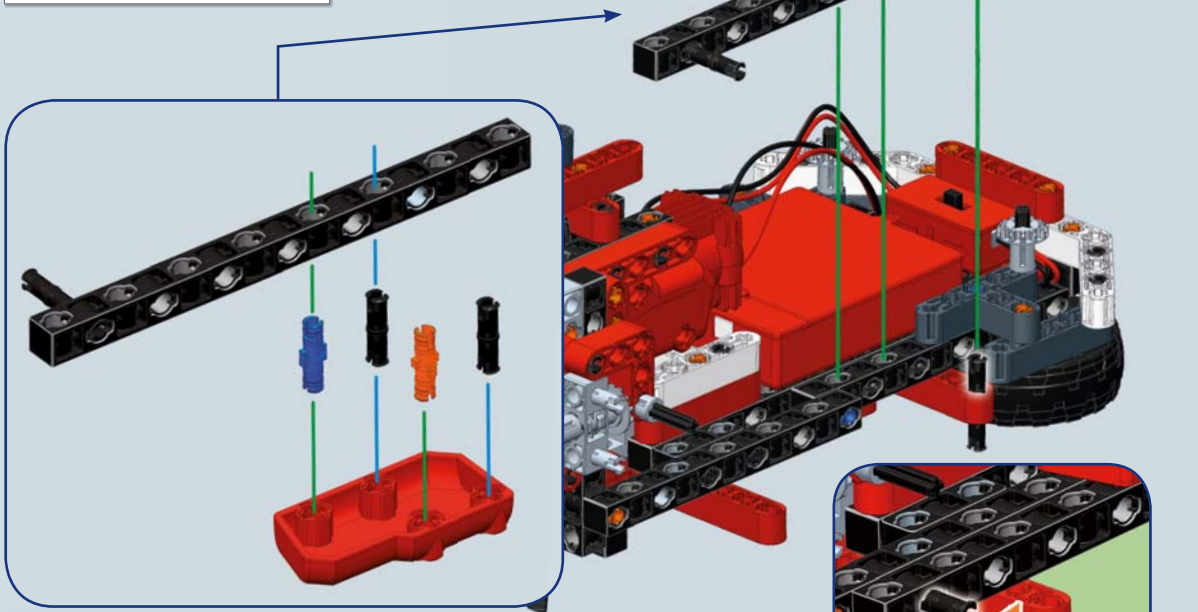
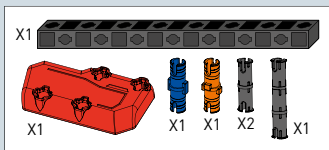



39







- X2  3
- X2 
- X4 
- X2 
- X2 
- X2 
- X4 
- X2 

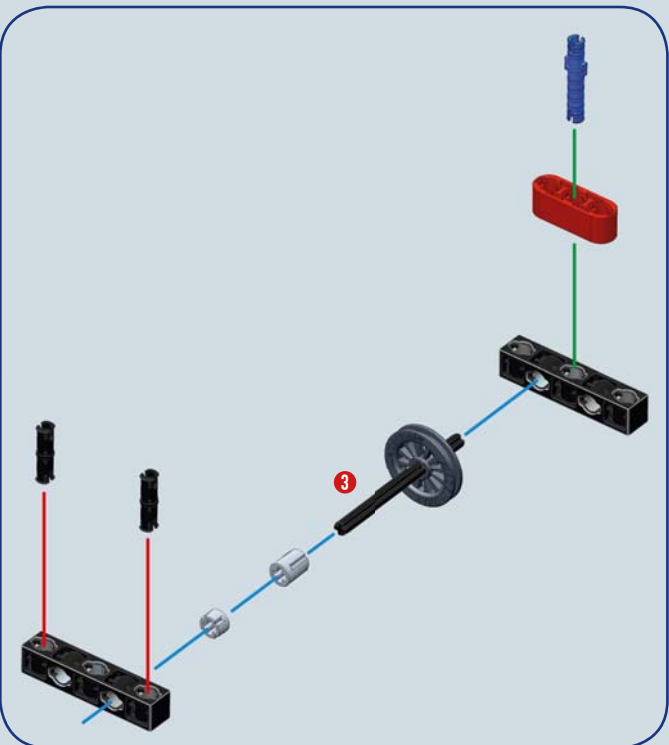
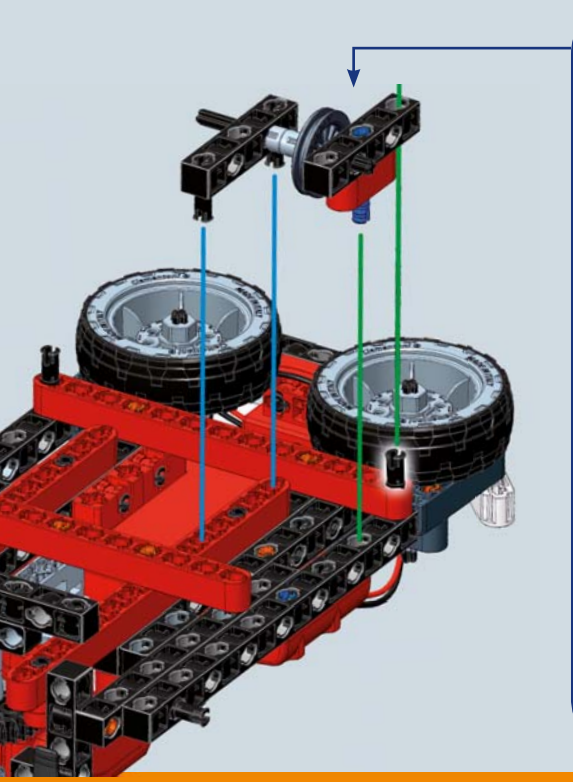
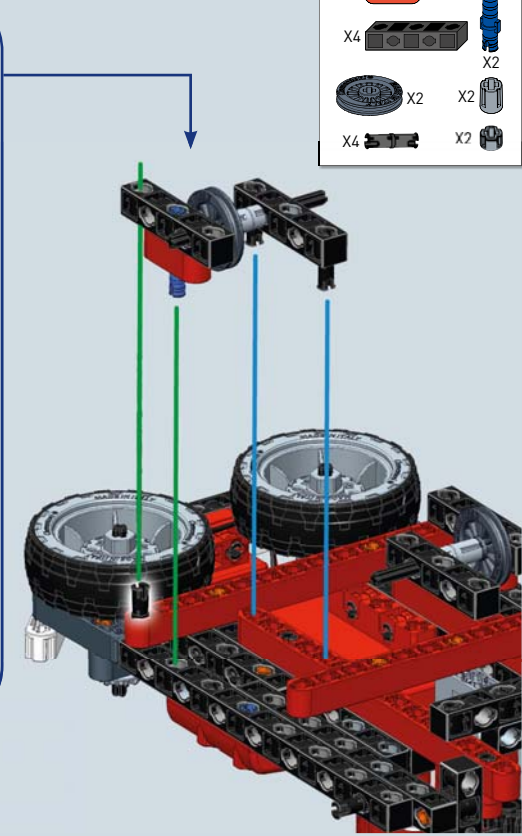
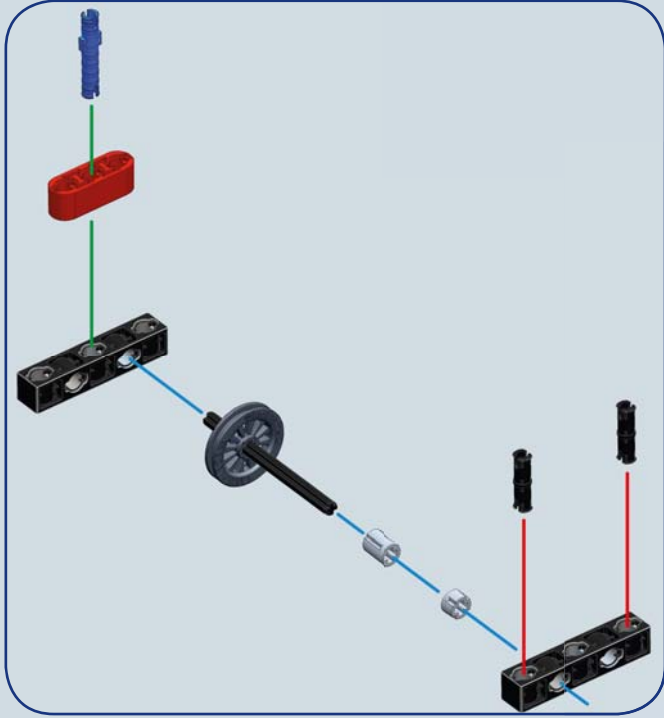



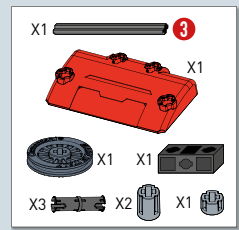
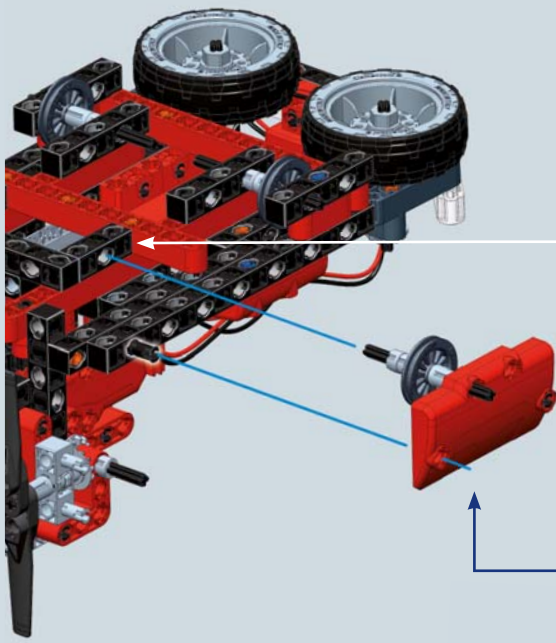

43

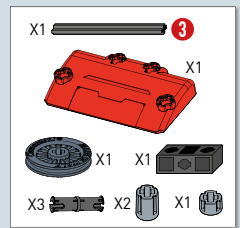
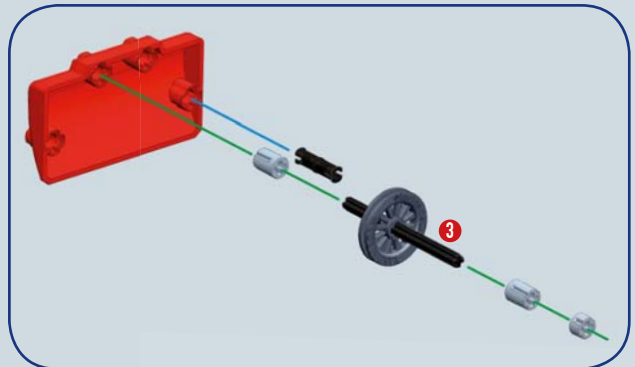
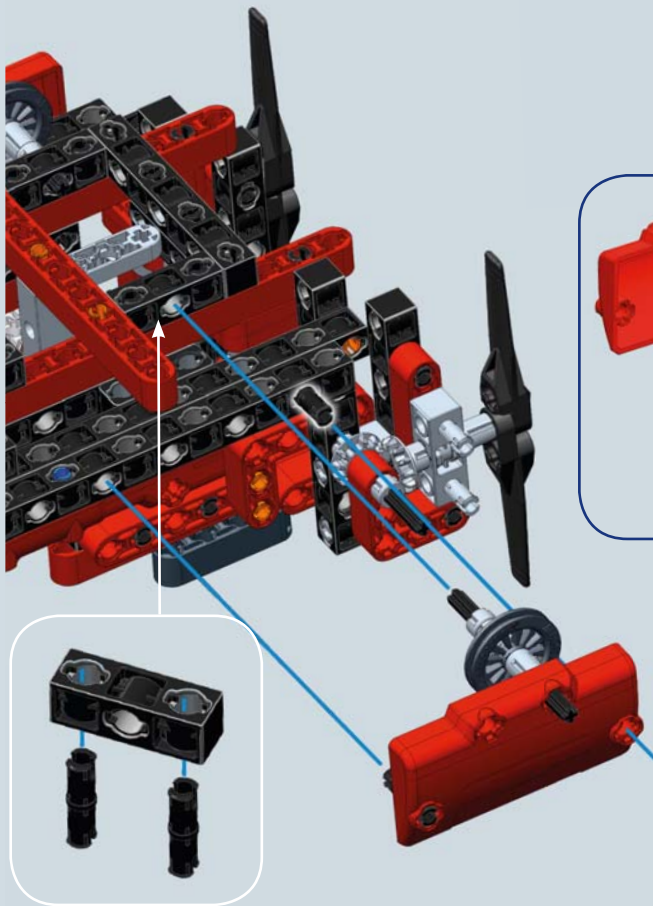
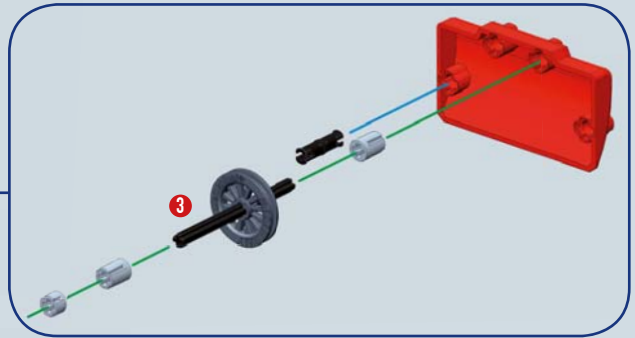

44



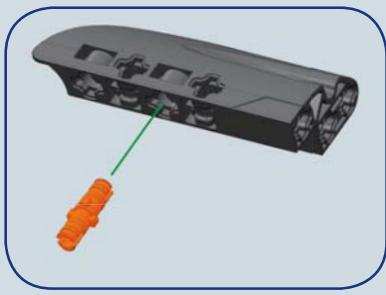

45

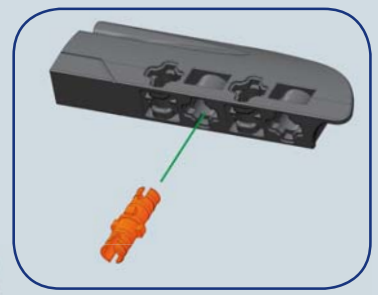
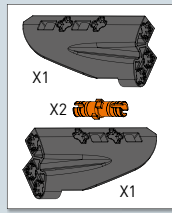

46

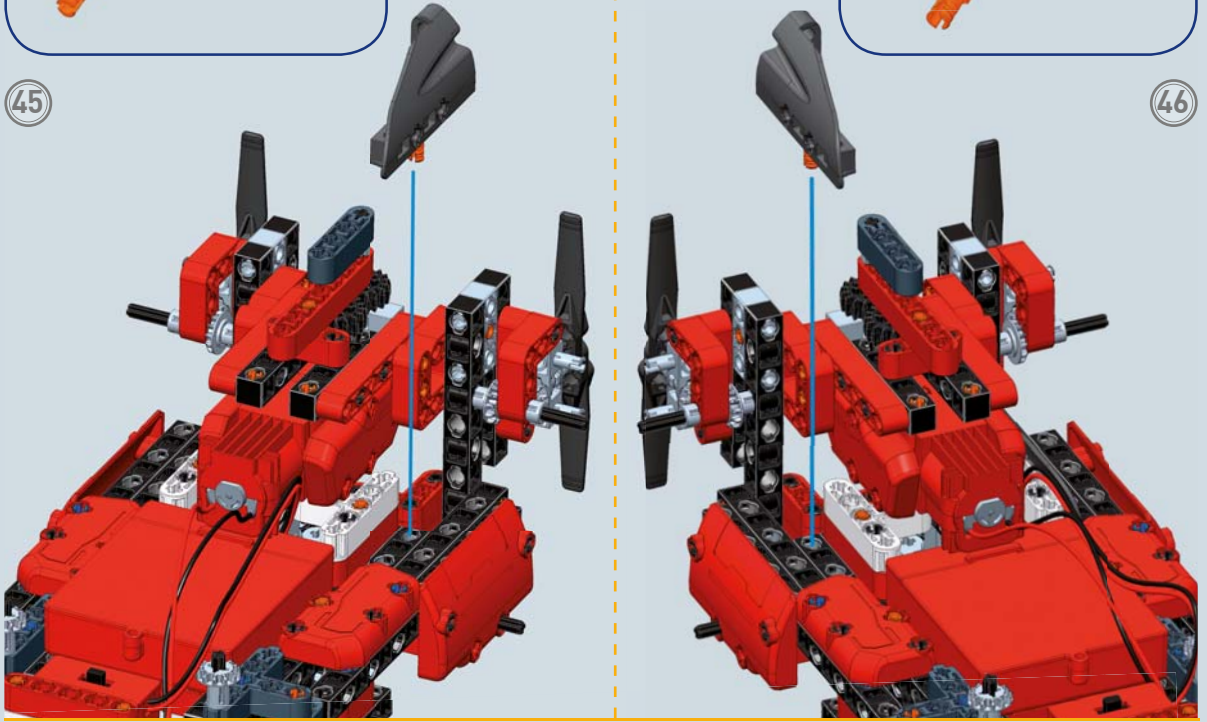

47

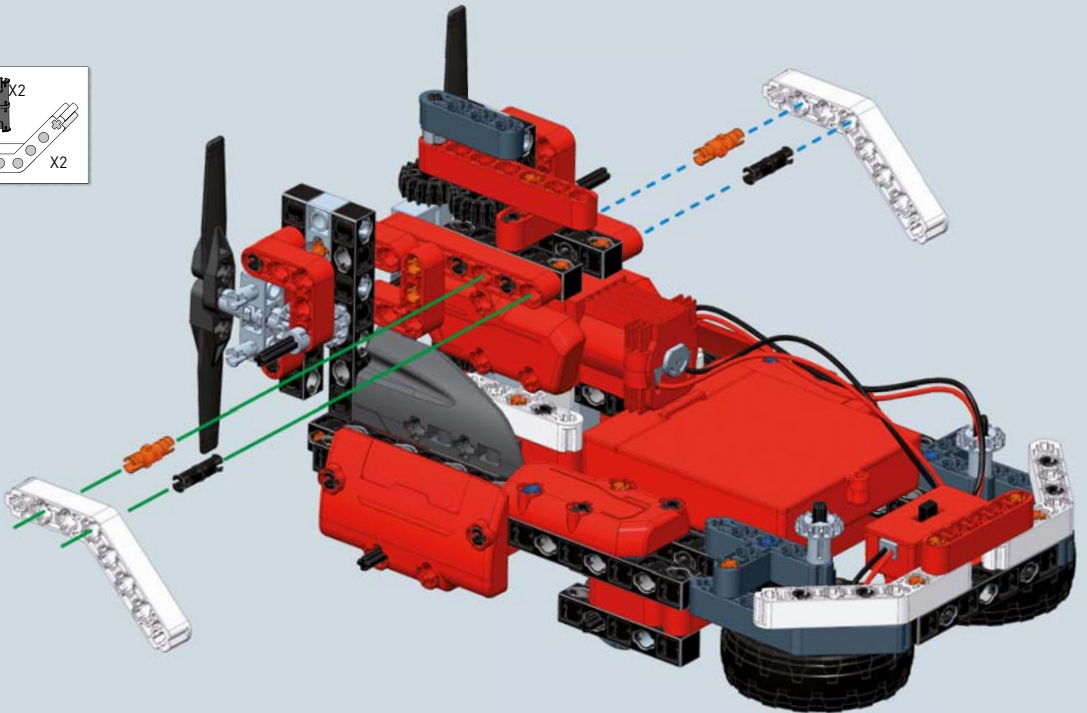
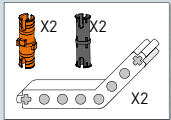

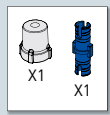

48

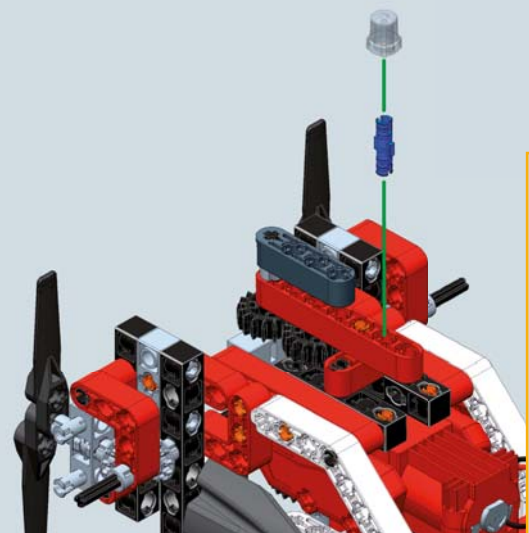

49

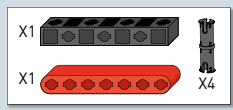
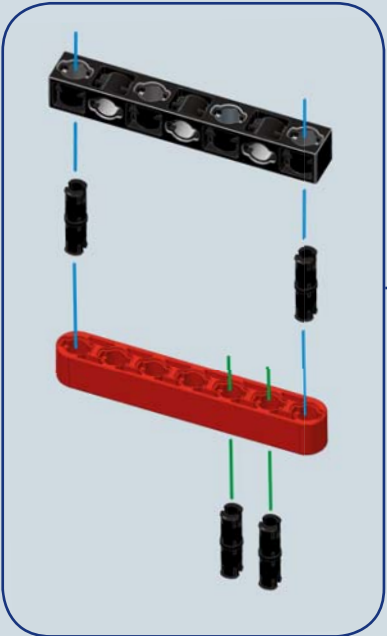
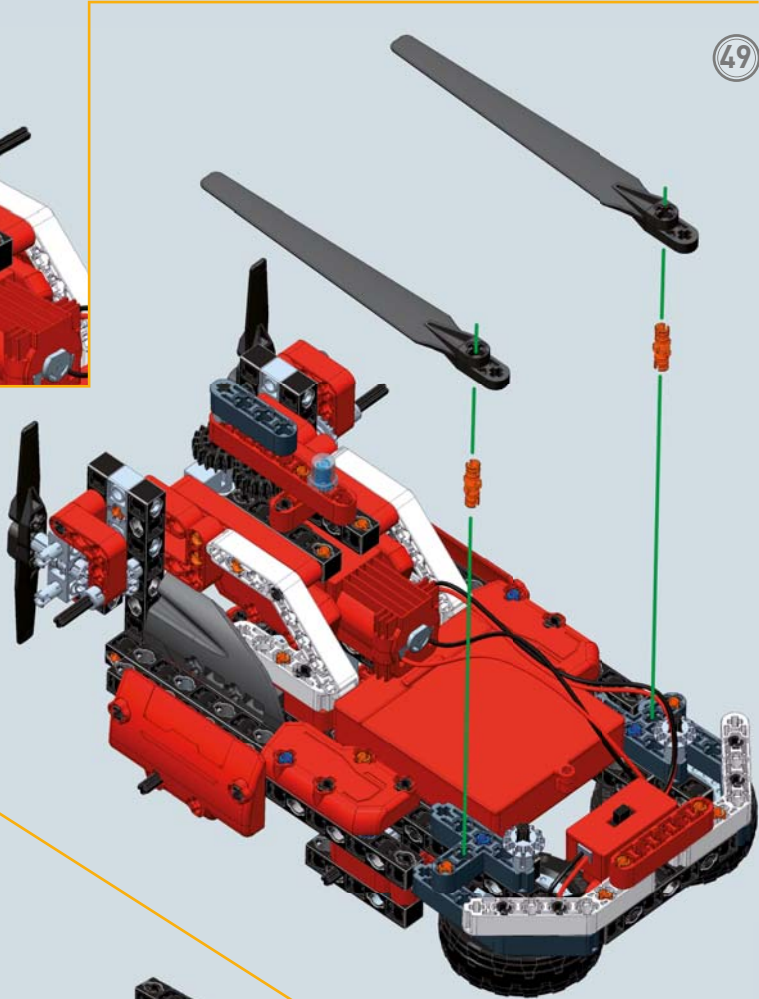
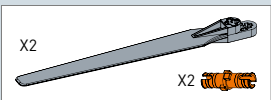

50

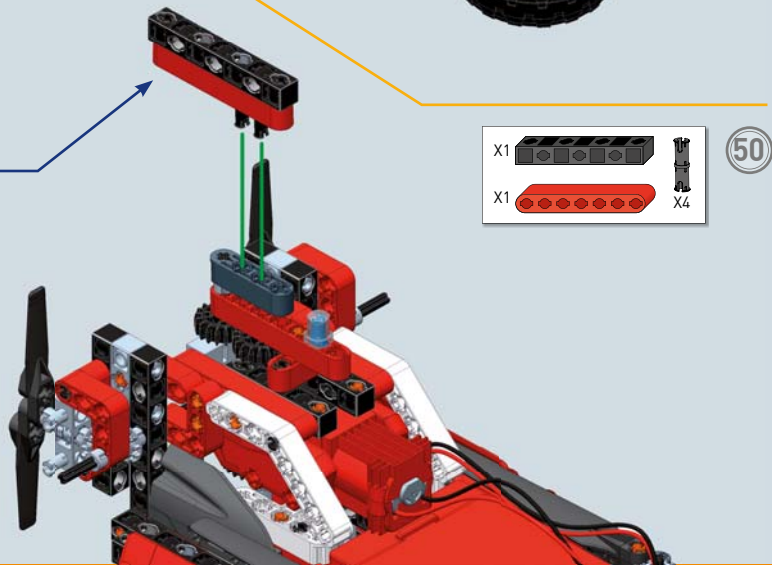



51

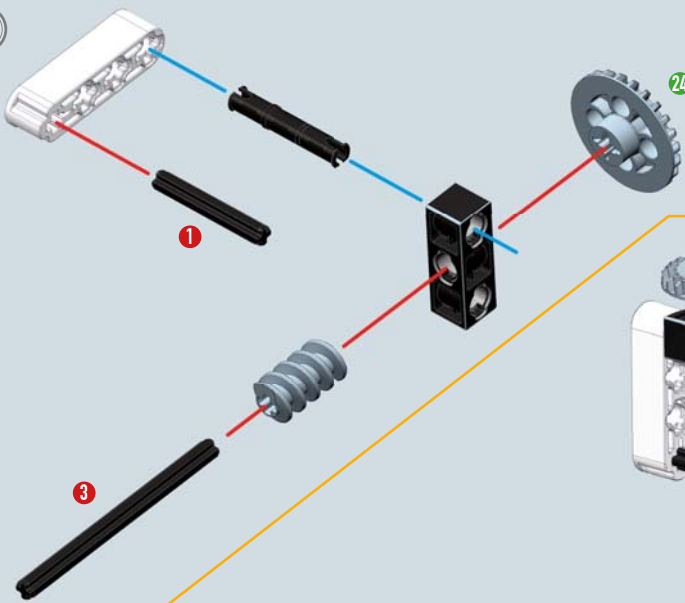

- X1 3
- X1 1
- X1 24
- X1 X1
- X1 X1
- X1 X1
- X1 X1

52

- X1 X1
- X1 X1
- X2 X2
- X1 X1

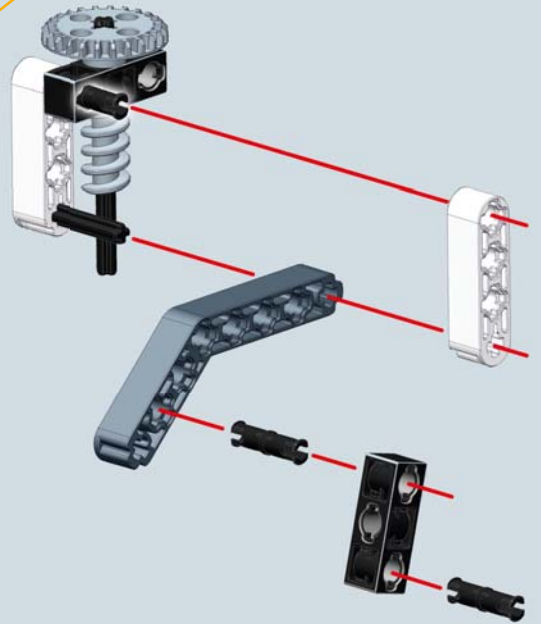

53

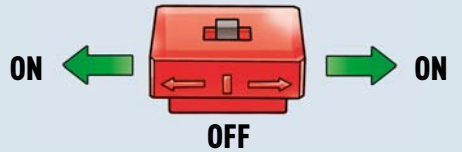
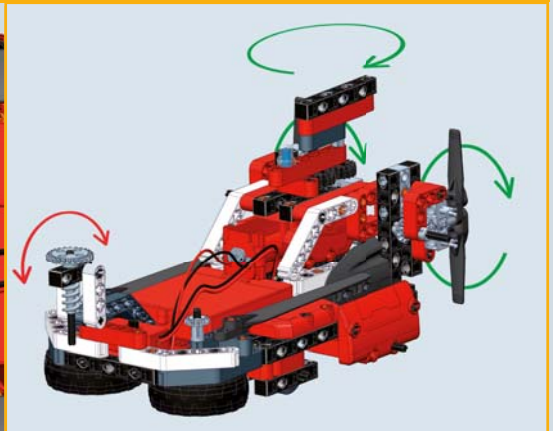
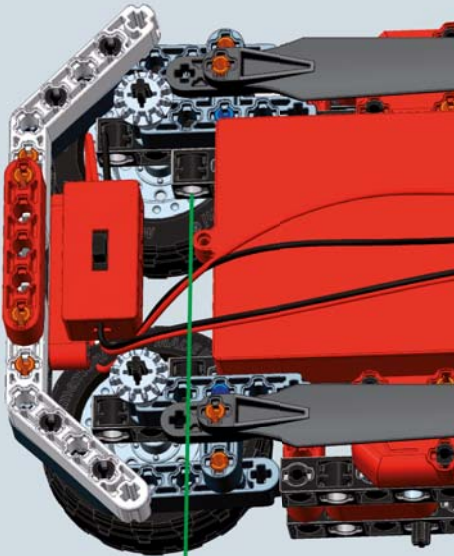

Gebruik de schakelaar om de rotatie van de achterwielen te starten.

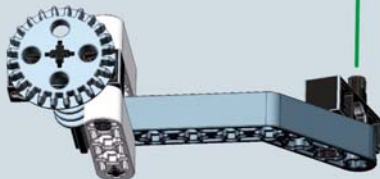

1:1 1

1:1 3





De takelwagen is een noodhulpvoertuig ontworpen om motorvoertuigen met technische problemen weg te slepen naar een andere plaats

Meestal wordt hij gebruikt voor het wegslepen van voertuigen die door een ongeval buiten de rijbaan terecht kwamen, op moeilijk toegankelijke plaatsen.



1

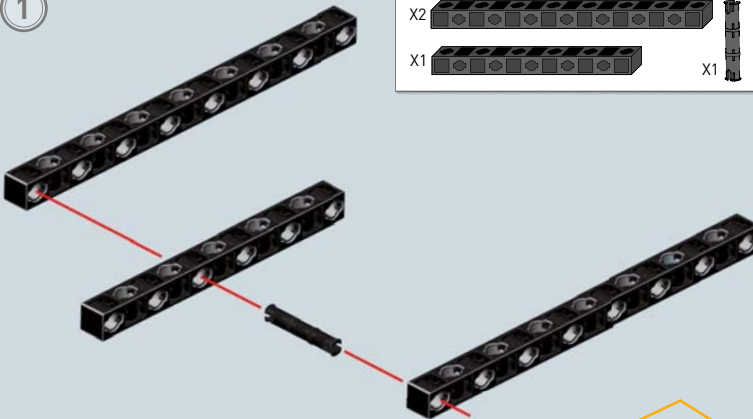

2

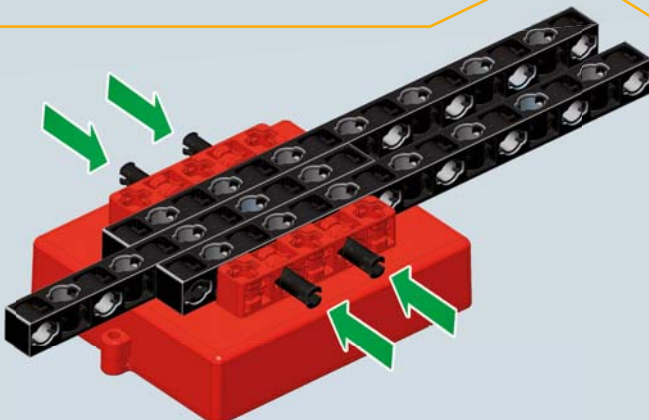
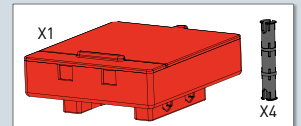
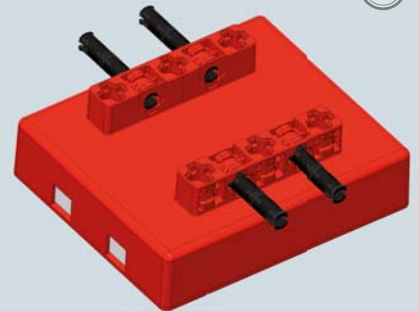

3

4

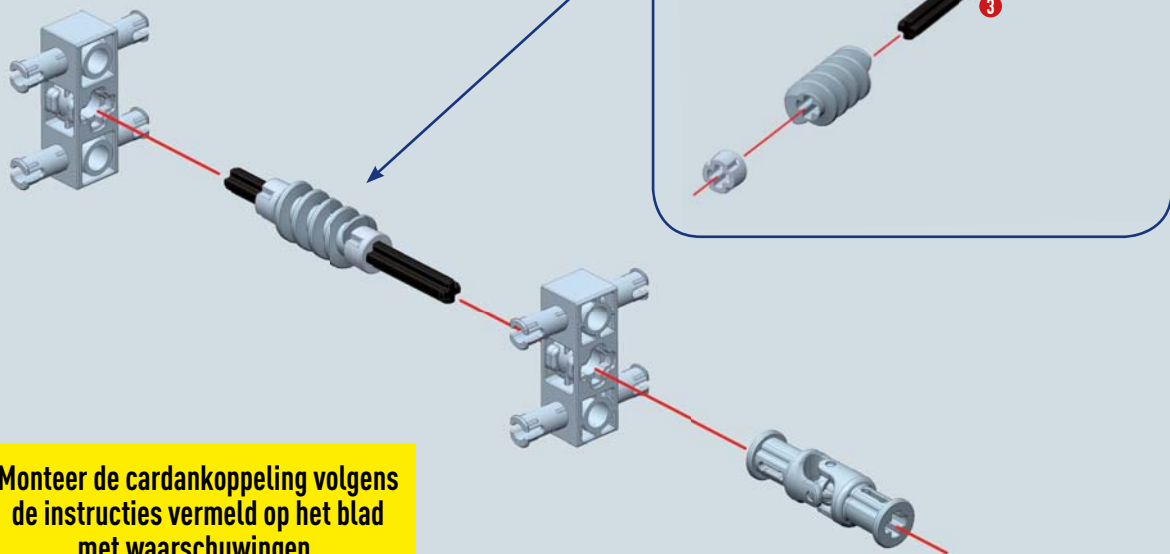
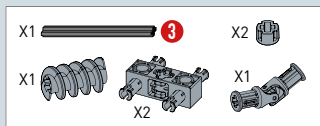

Monteer de cardankoppeling volgens de instructies vermeld op het blad met waarschuwingen.

5

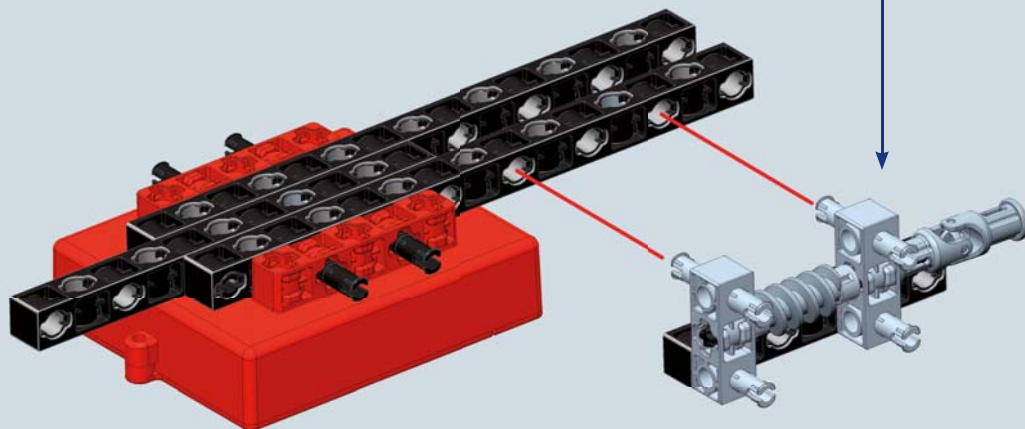
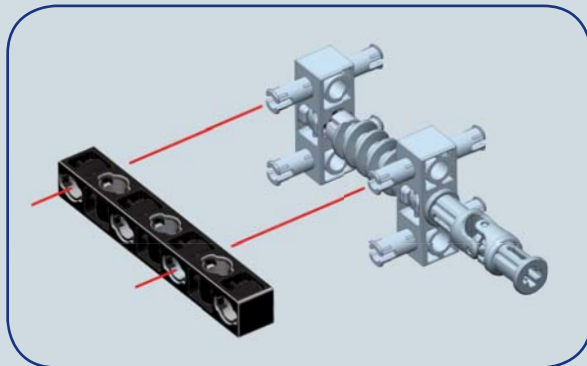

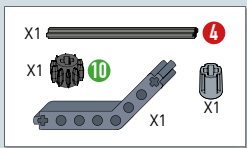

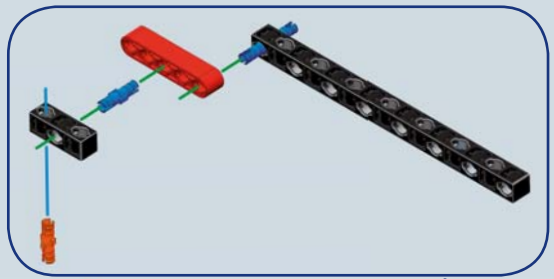
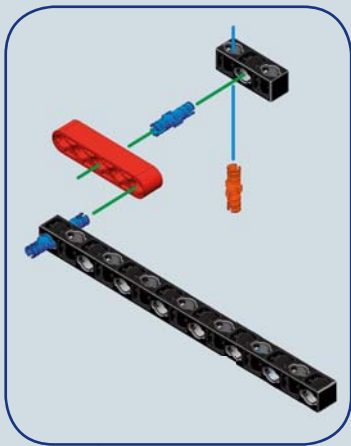
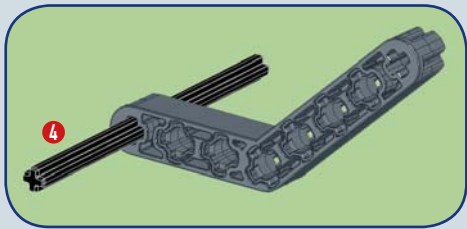
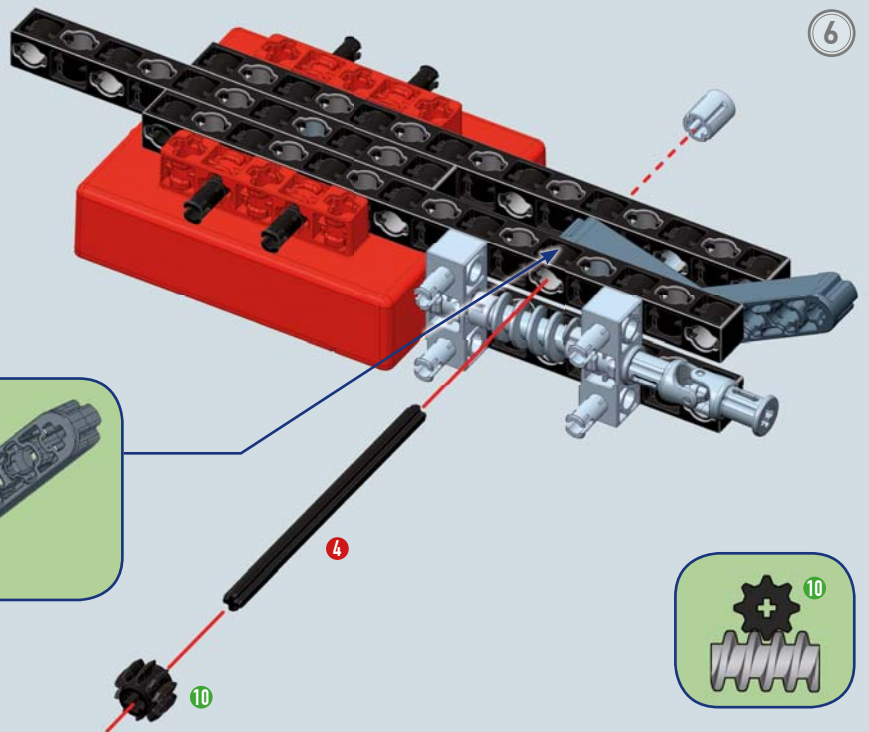

6

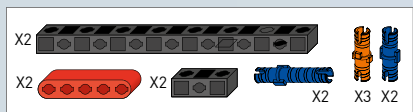
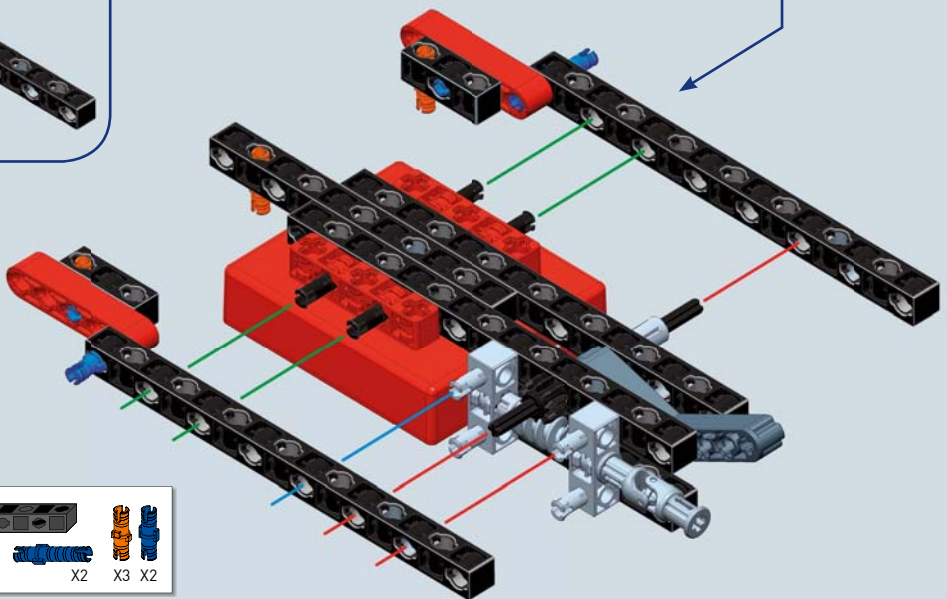

7



X1  5 X2 

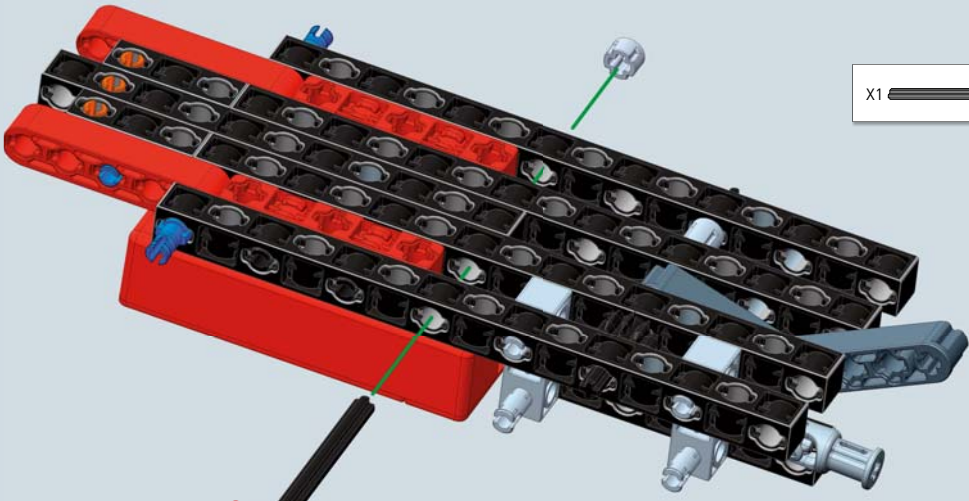



5

9

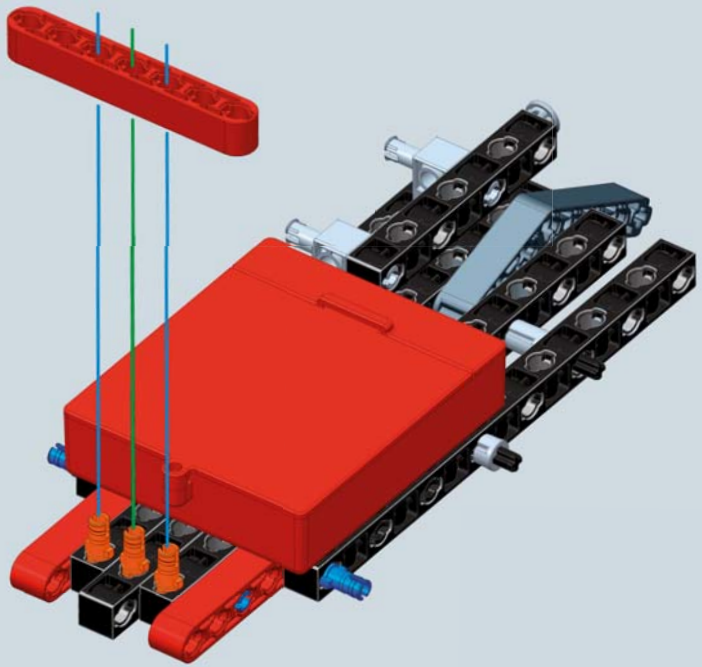
X1 



10

X2  X2  X4 

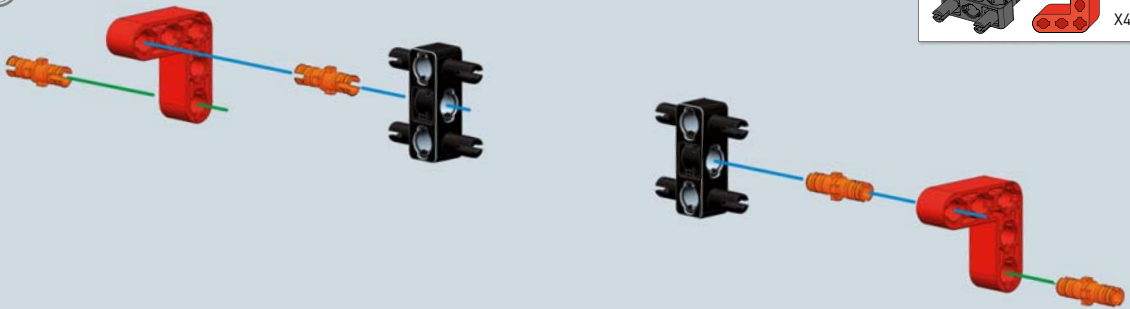



1:1  5 





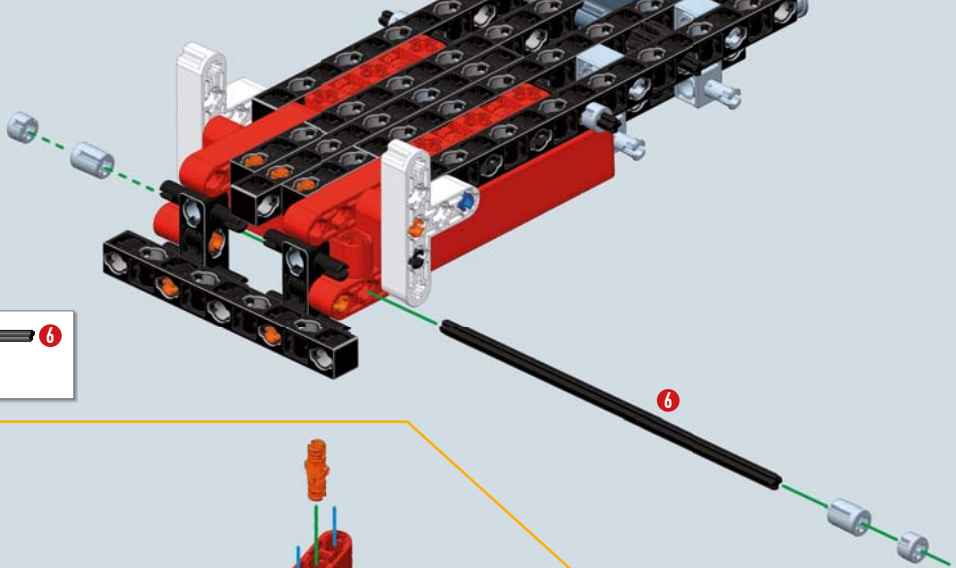



14

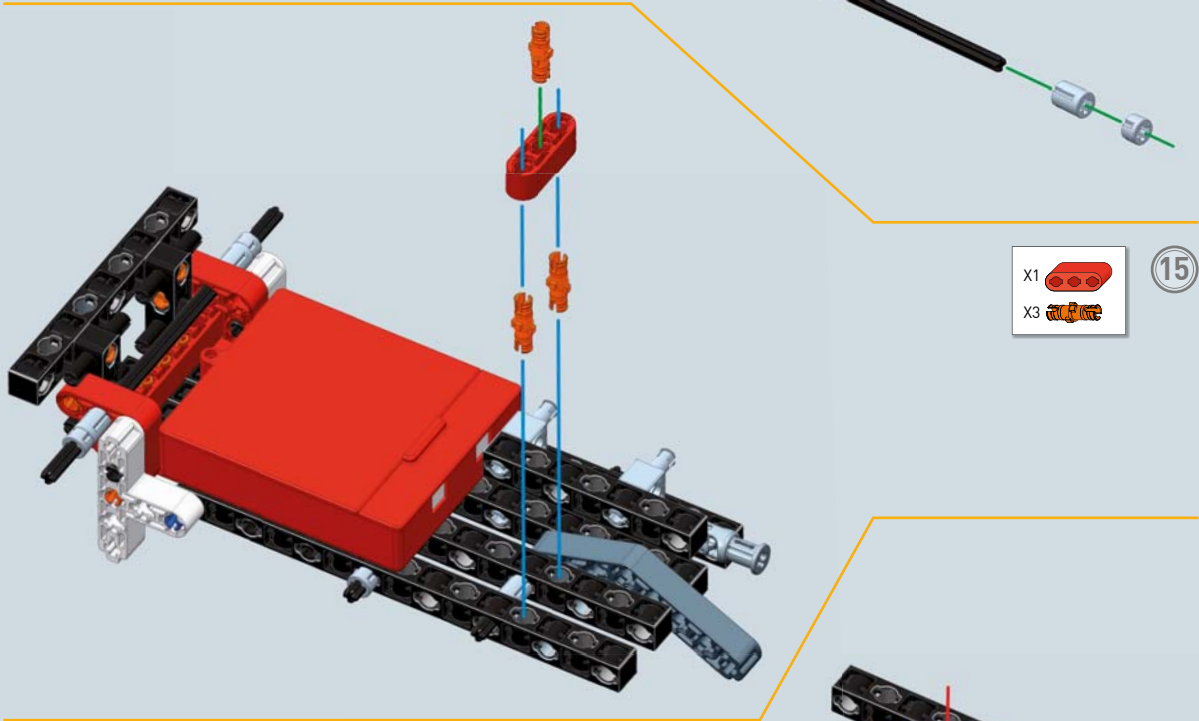

X1  6

X2  X2 



X1  15

X3 

16

X1  16

X2 

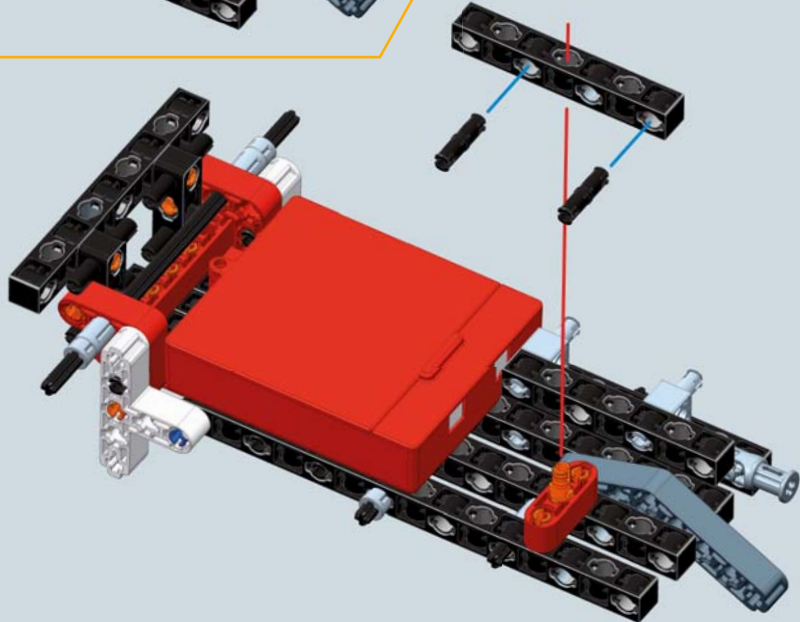

1:1



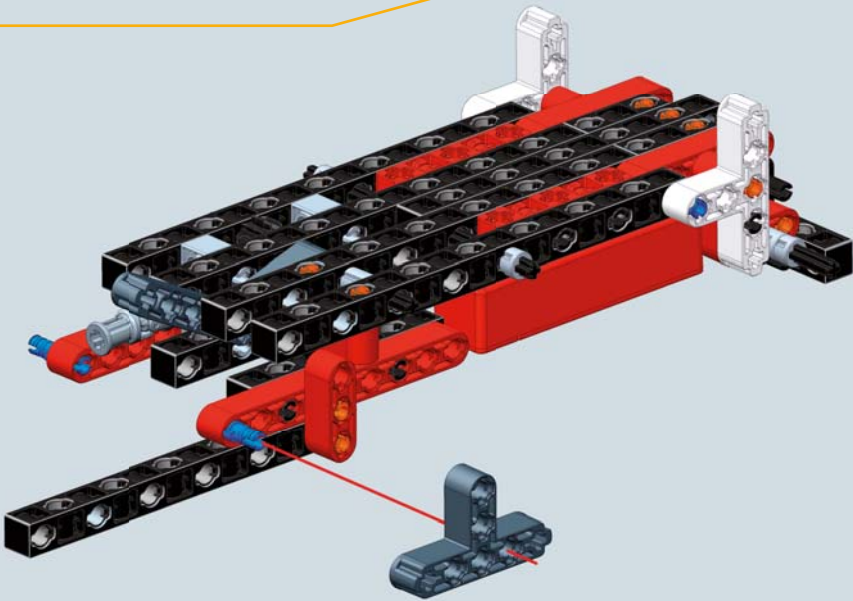
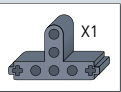
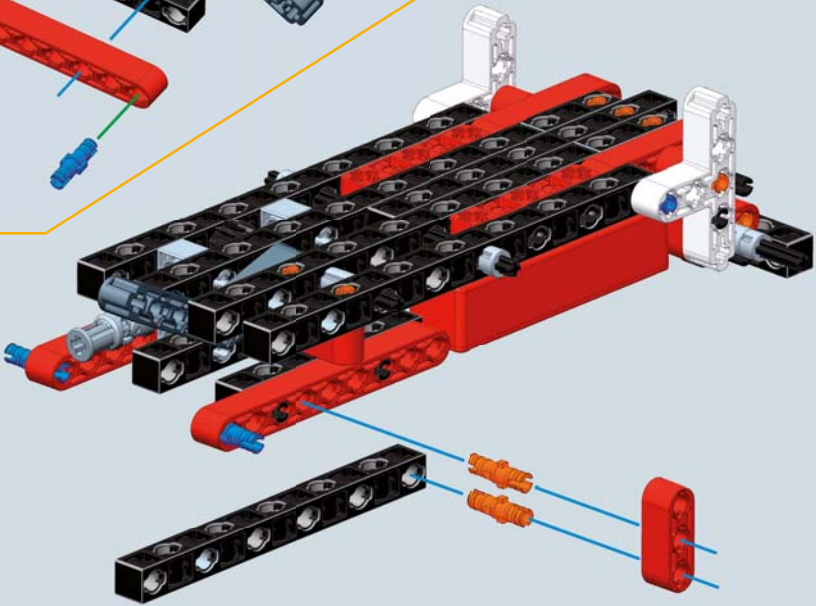
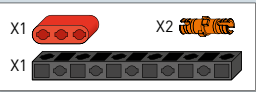
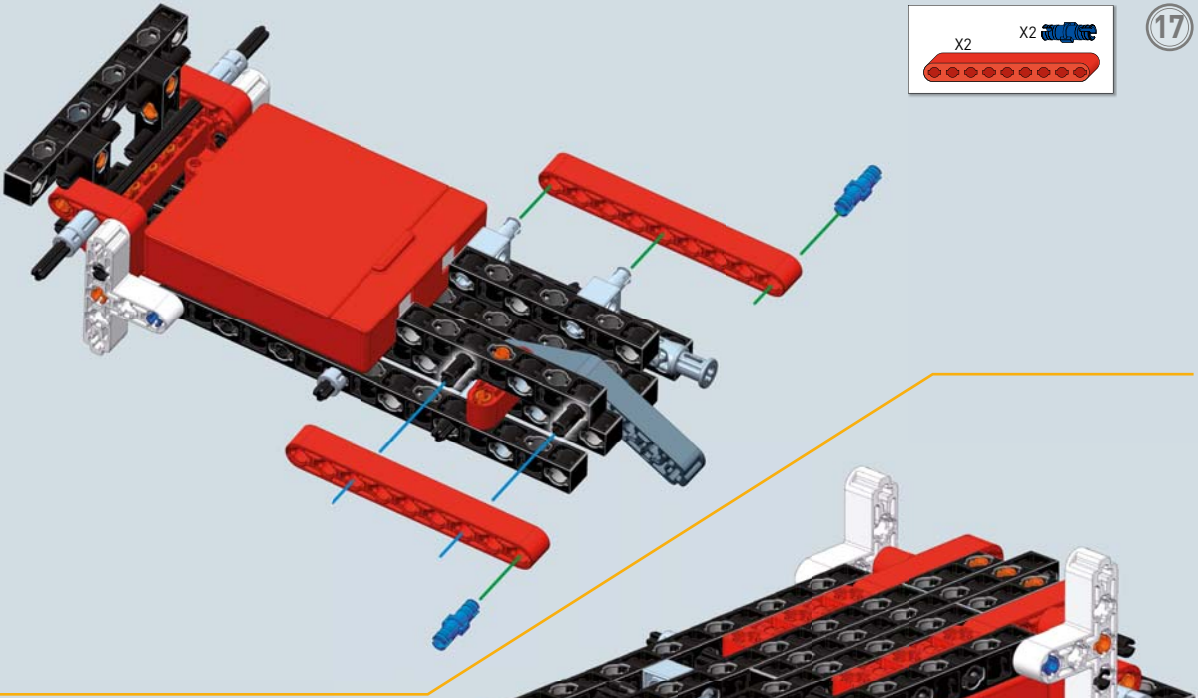
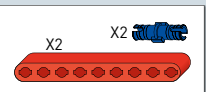



20

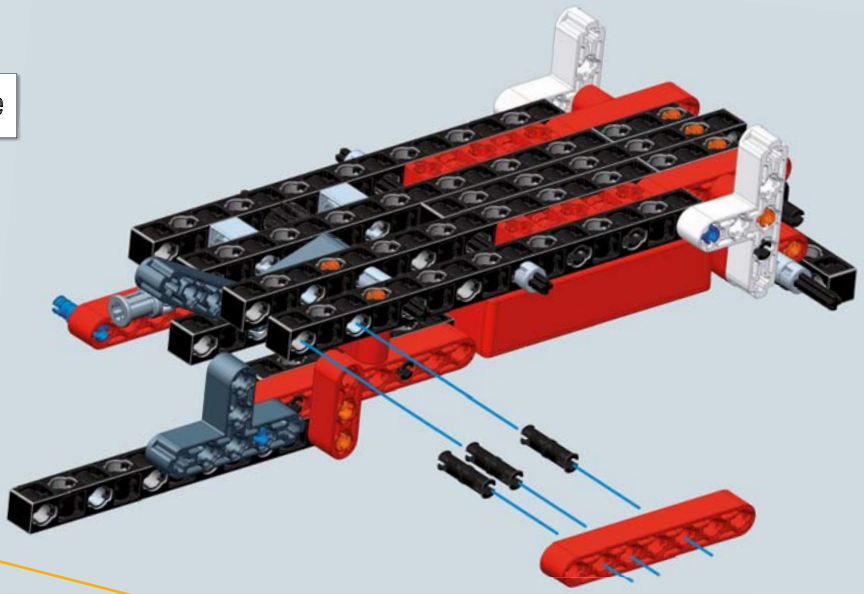
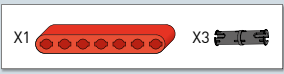

21

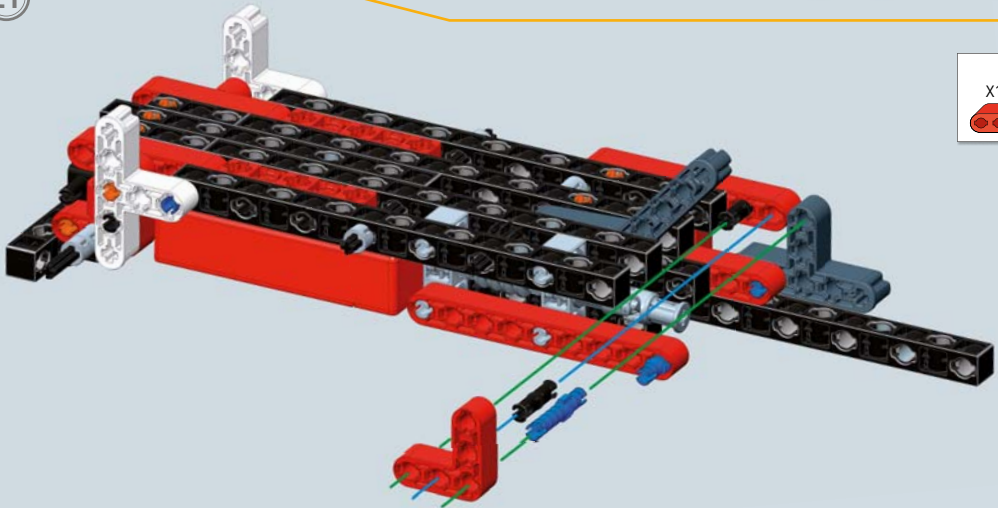
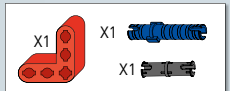

22

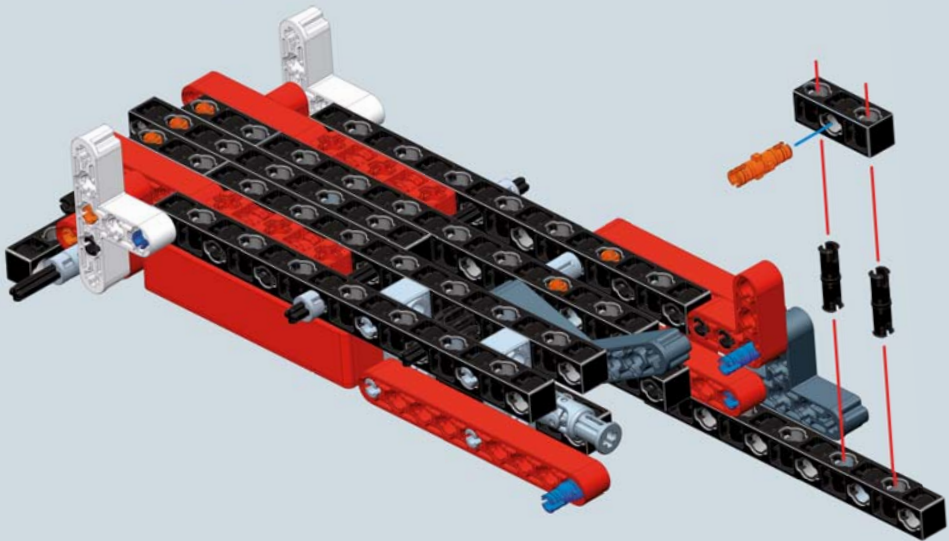
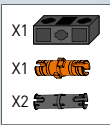



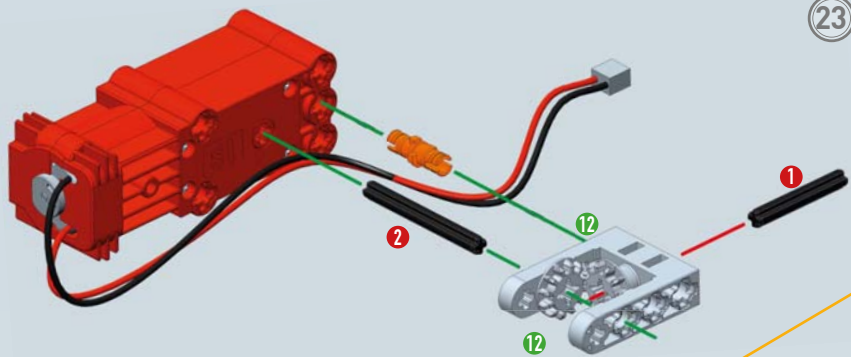
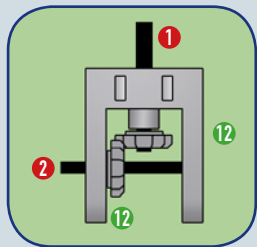
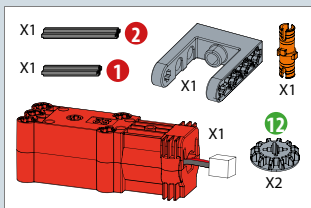

Verbind stangetje 1 aan de cardankoppeling.

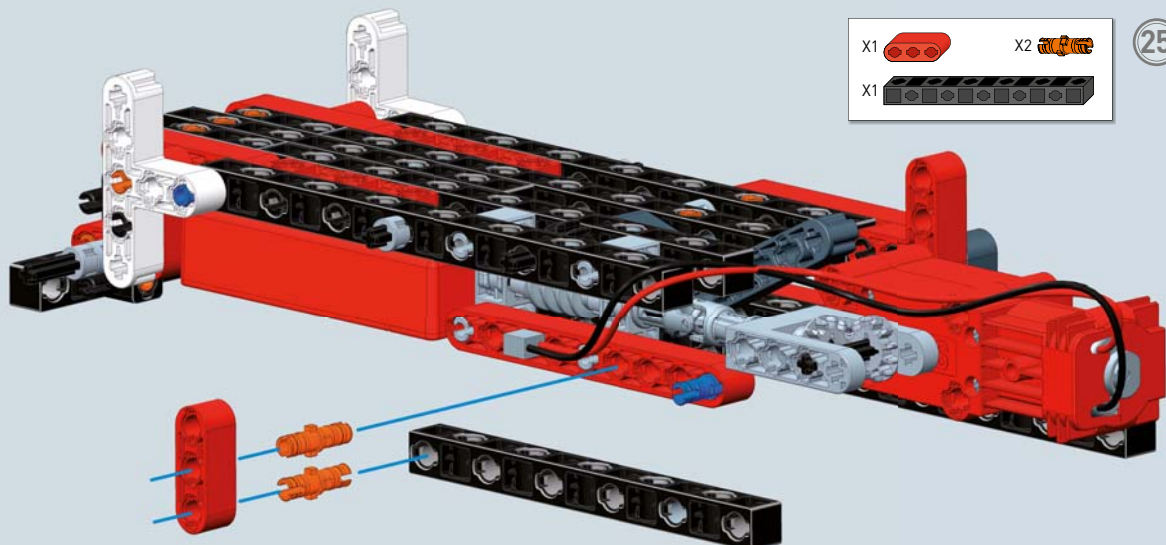
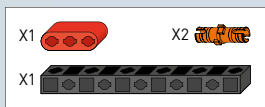
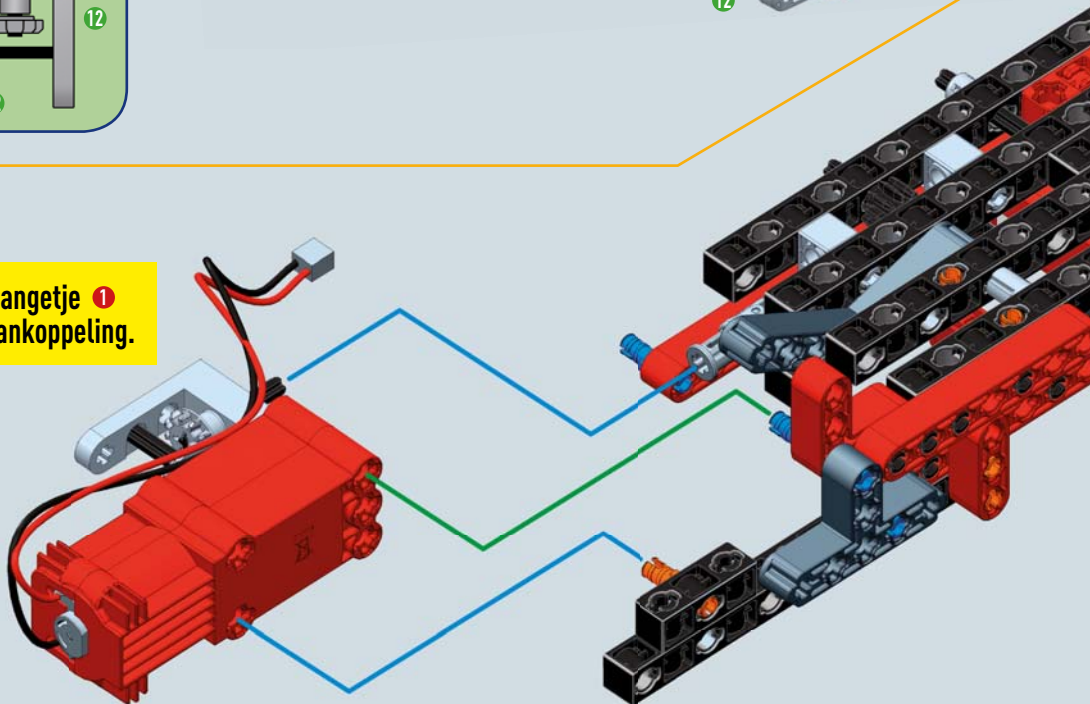

26

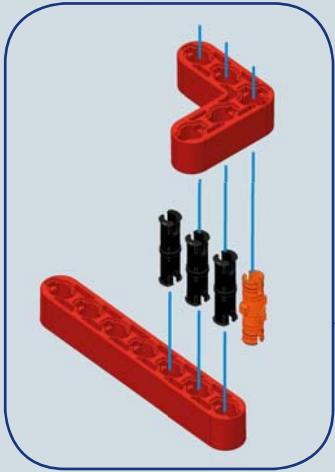
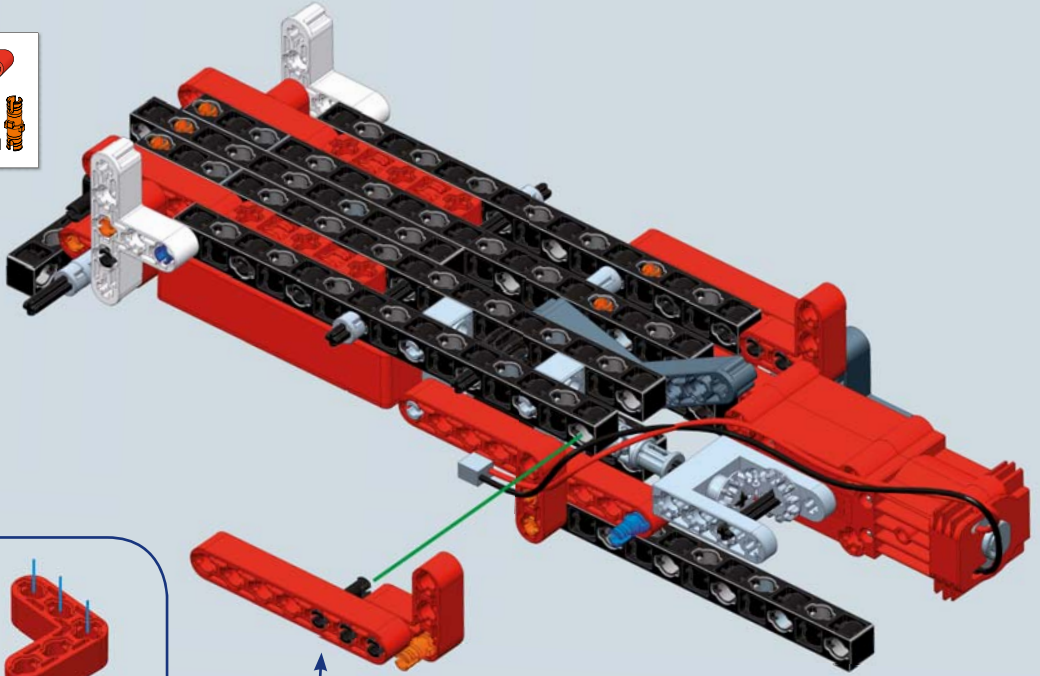
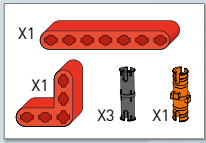

27

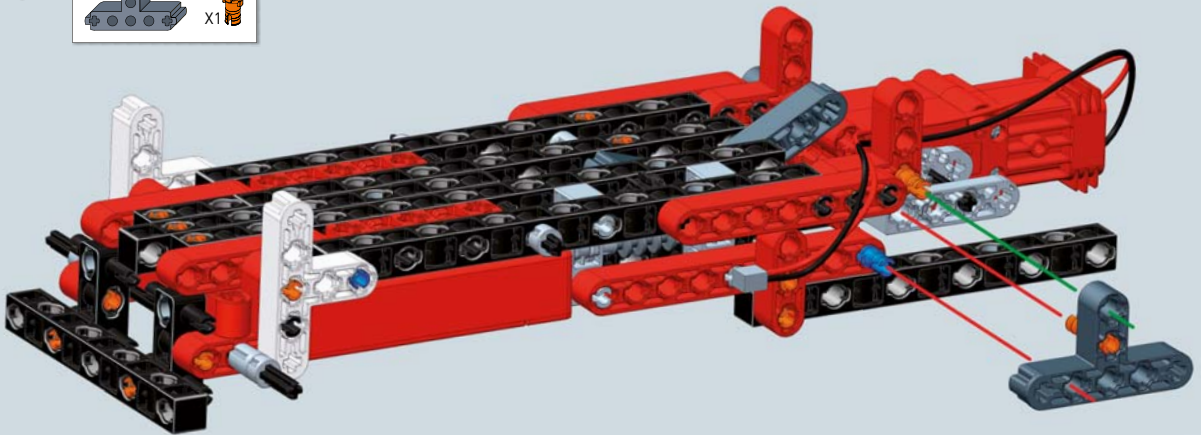
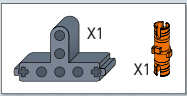

- X1  6
- X2 
- X1 

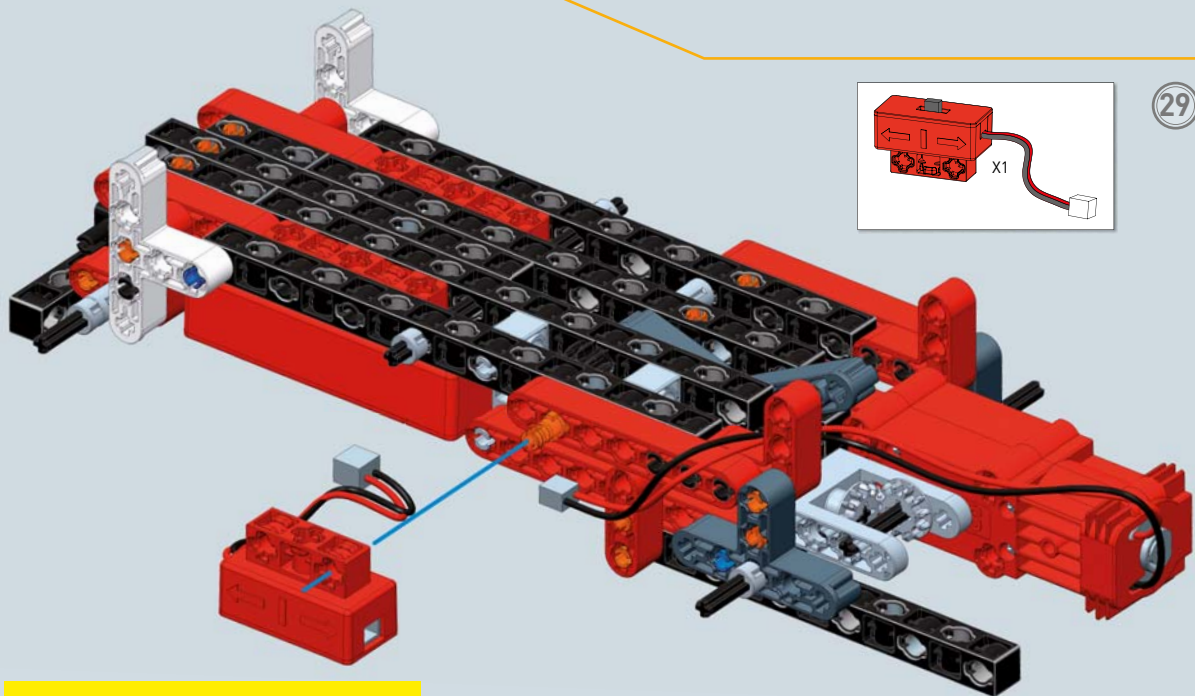
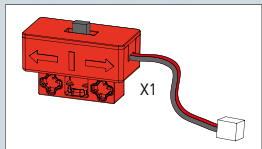
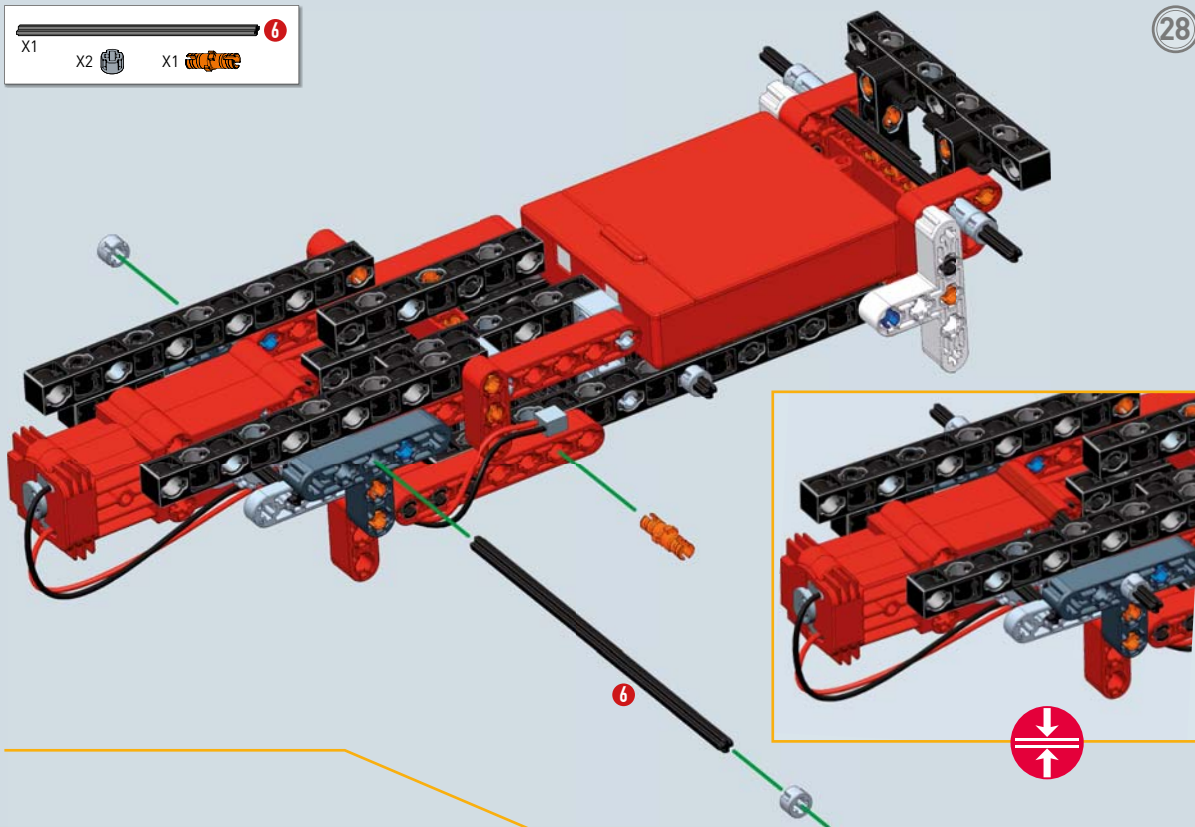



Sluit de kabel van de motor aan op de schakelaar en de kabel van de schakelaar aan op het batterijvak.

- 1:1  6



30

- X3 
- X2 

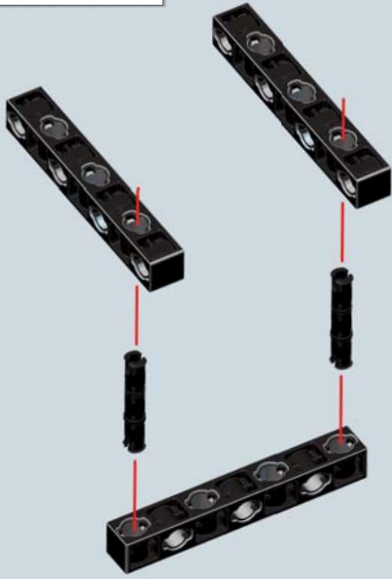



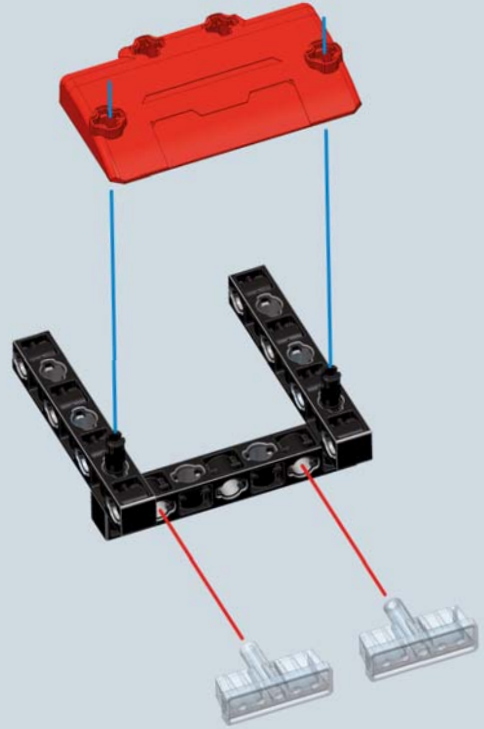

31

- X1 
- X2 



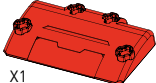

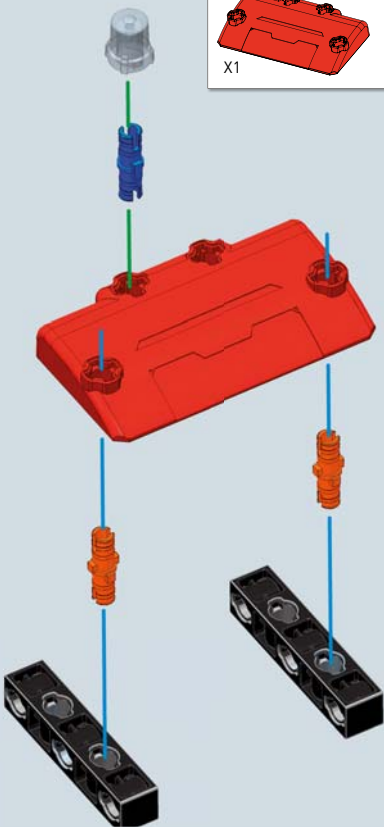

32

- X2 
- X1 
- X1 
- X1 
- X2 

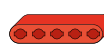

33

- X1 
- X1 
- X1 
- X2 

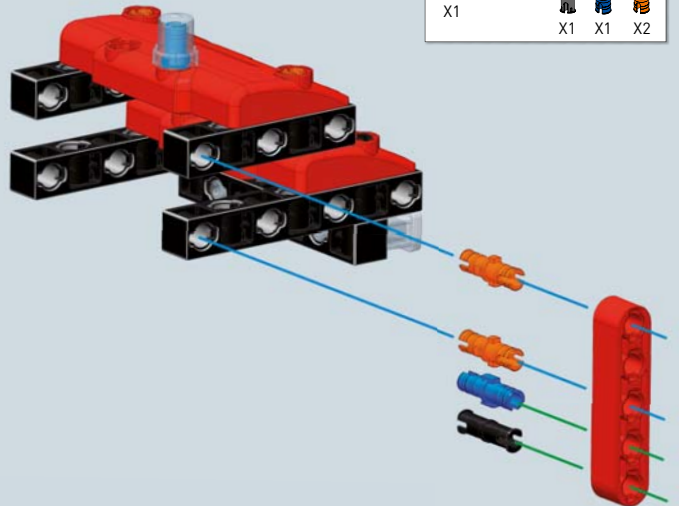

34

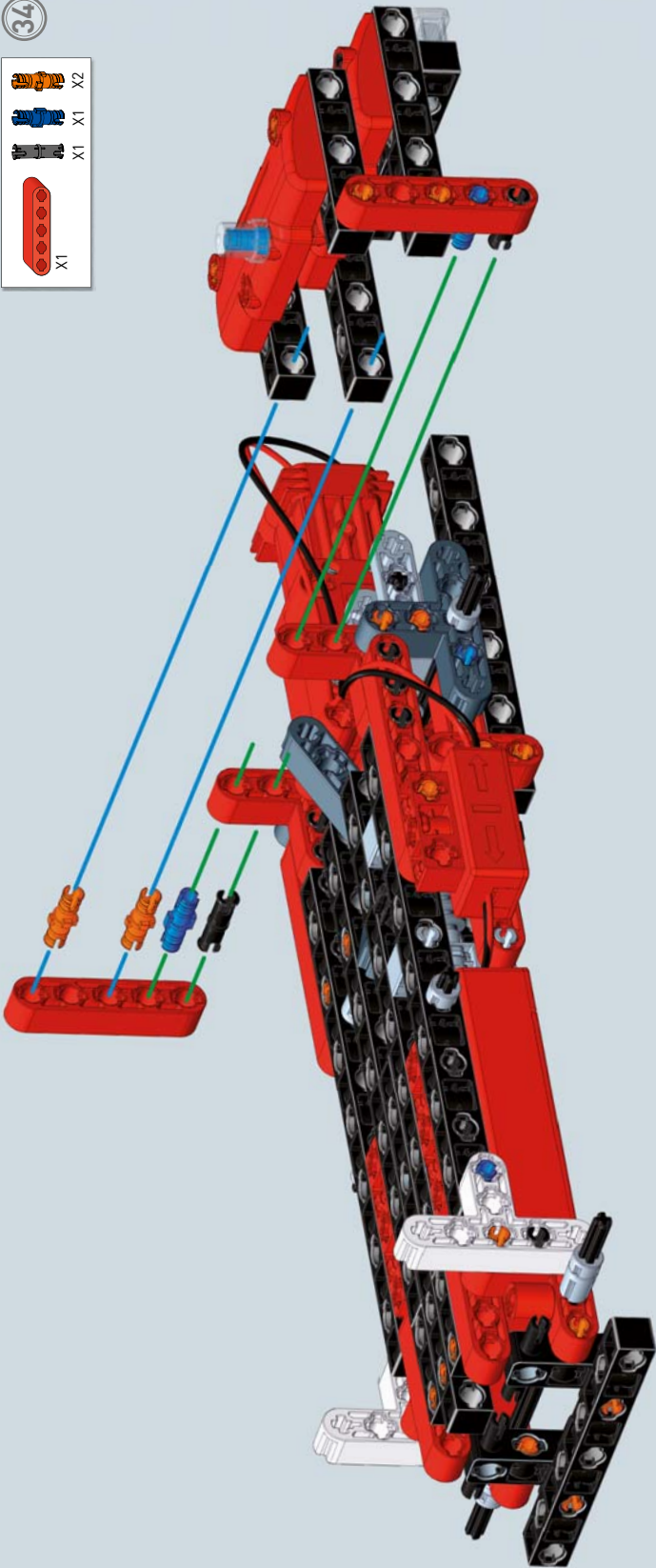
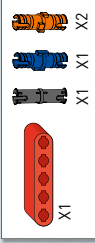

35

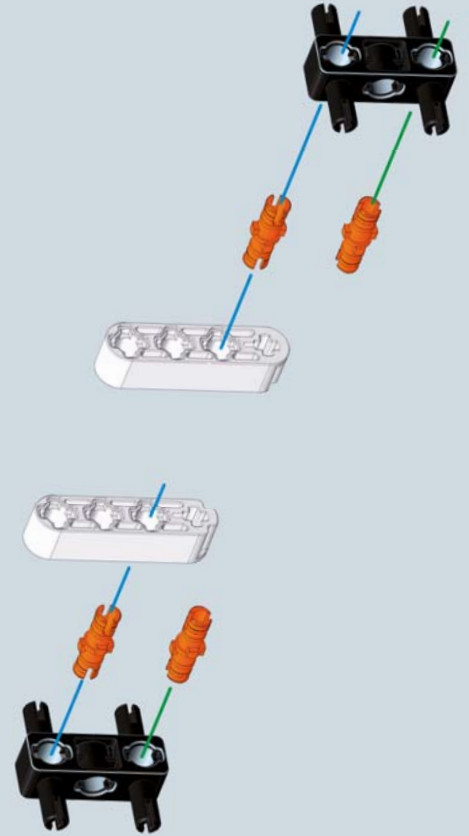
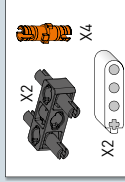

36

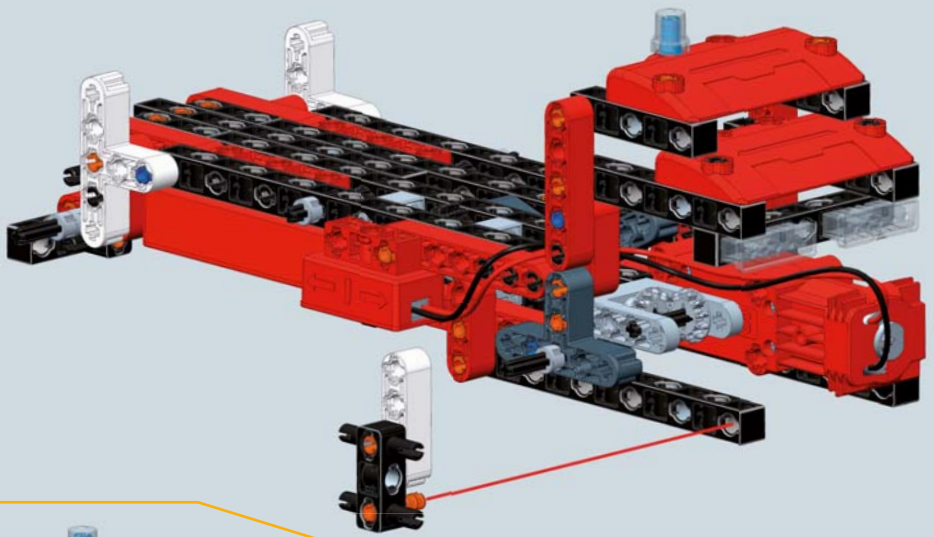

37

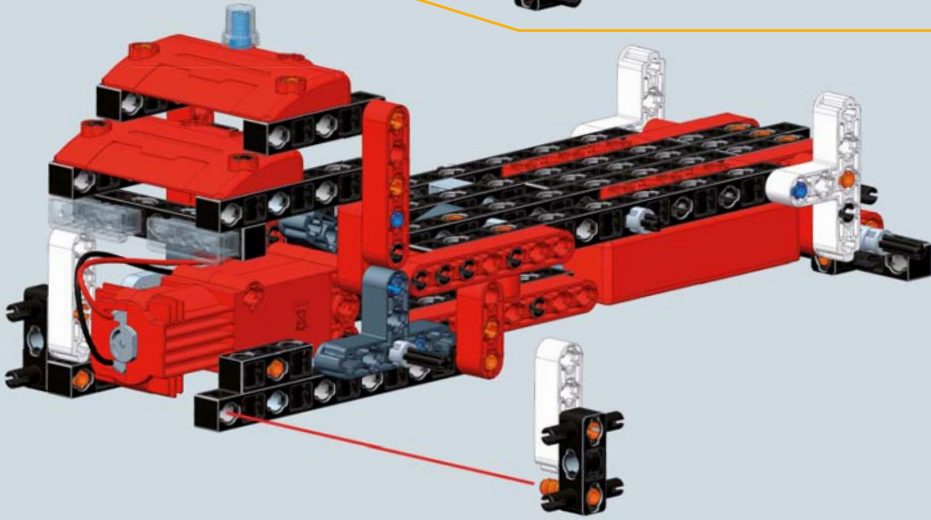

38

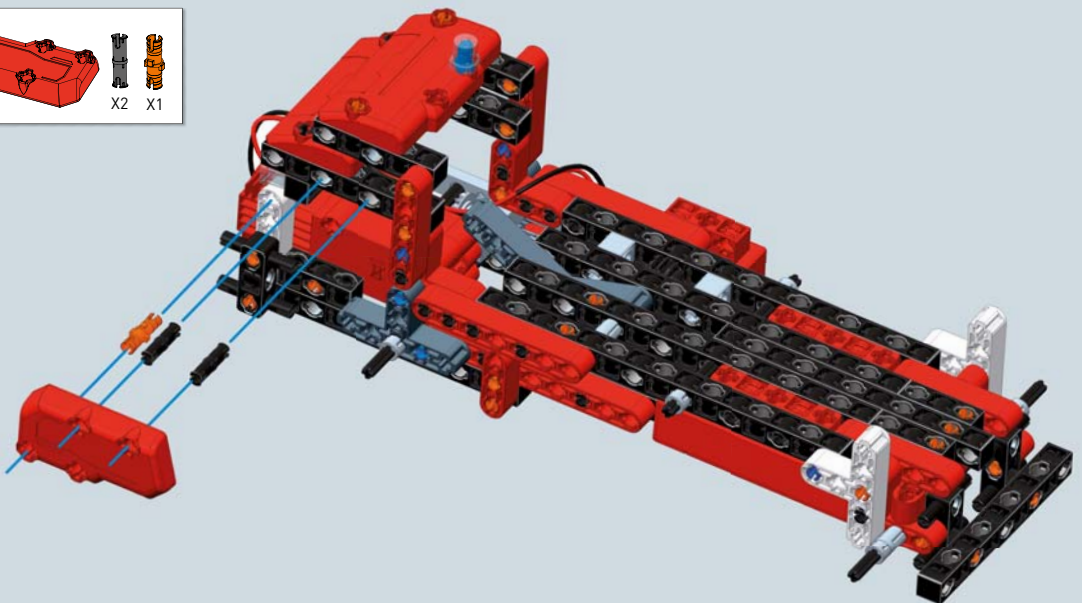
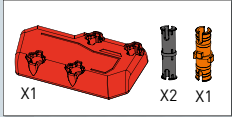



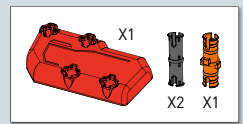
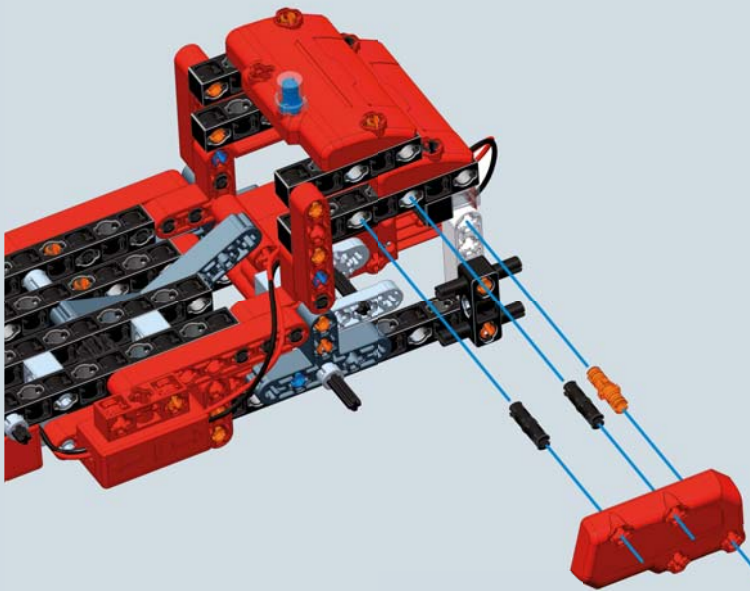

39

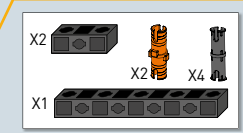

40

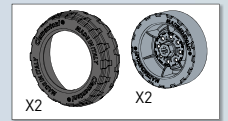
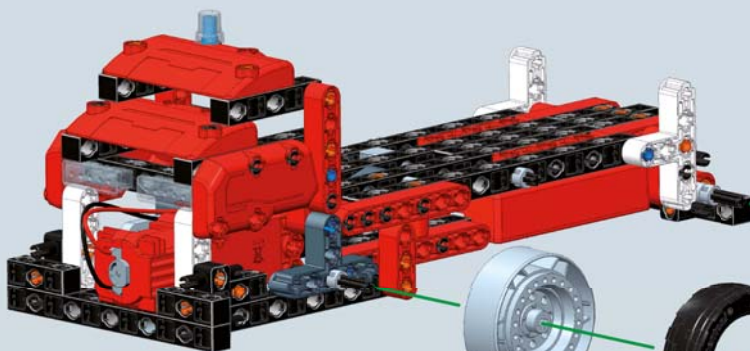
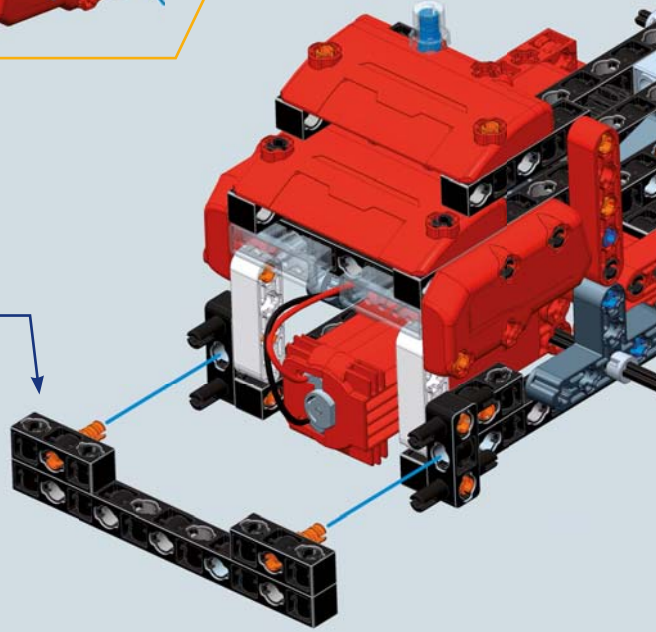
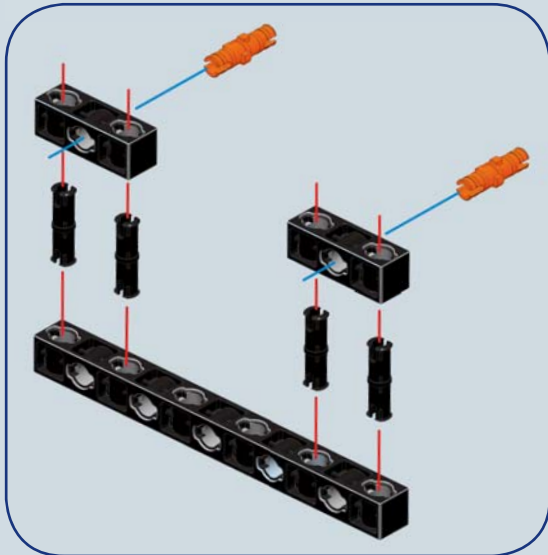

41

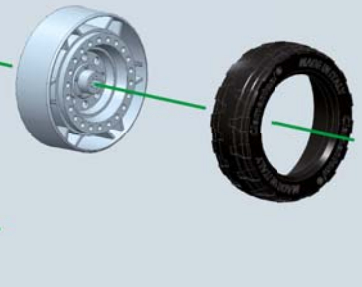

42

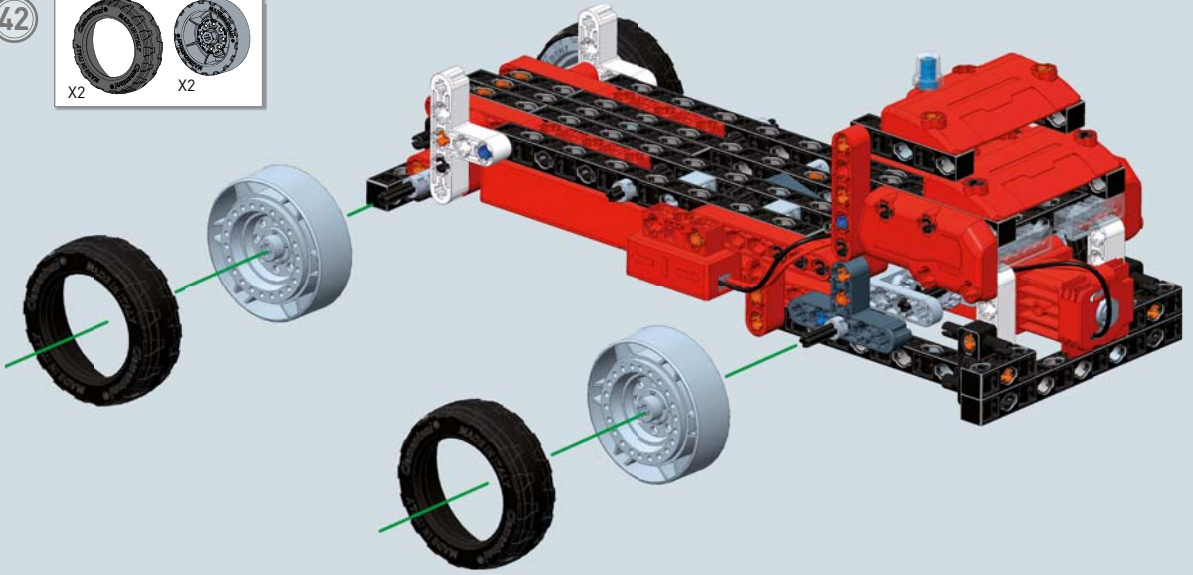
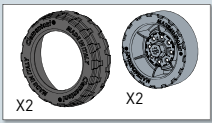

43

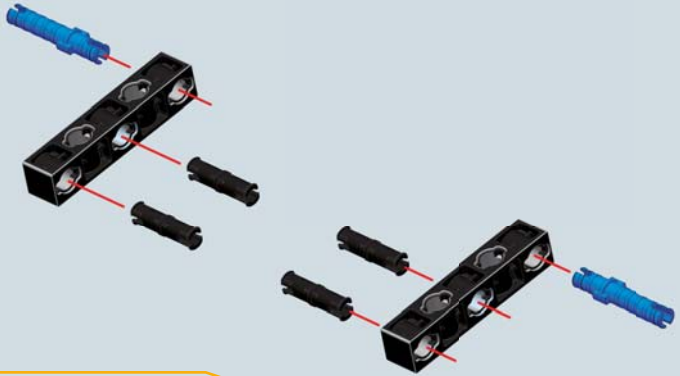
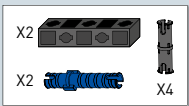

44

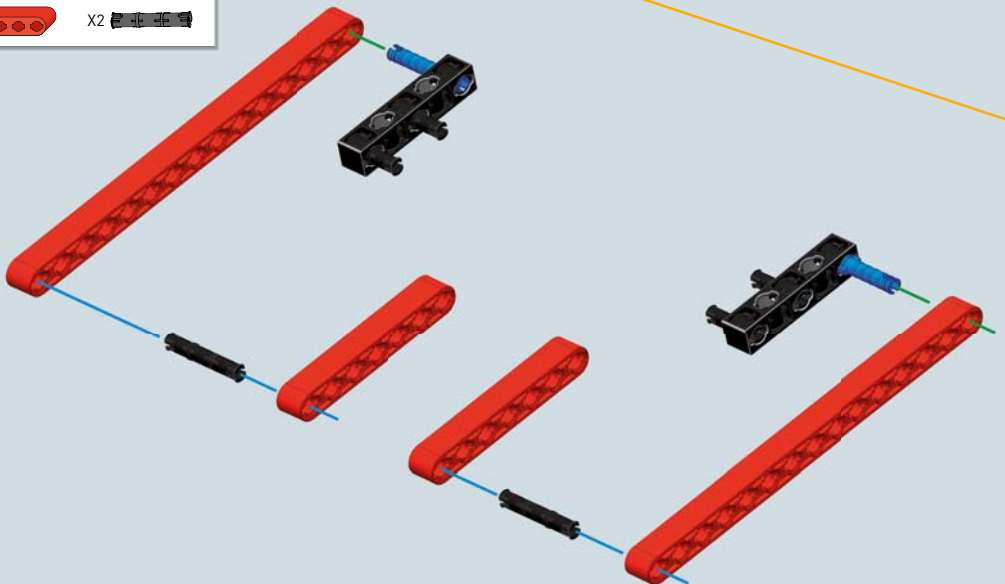
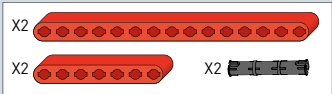

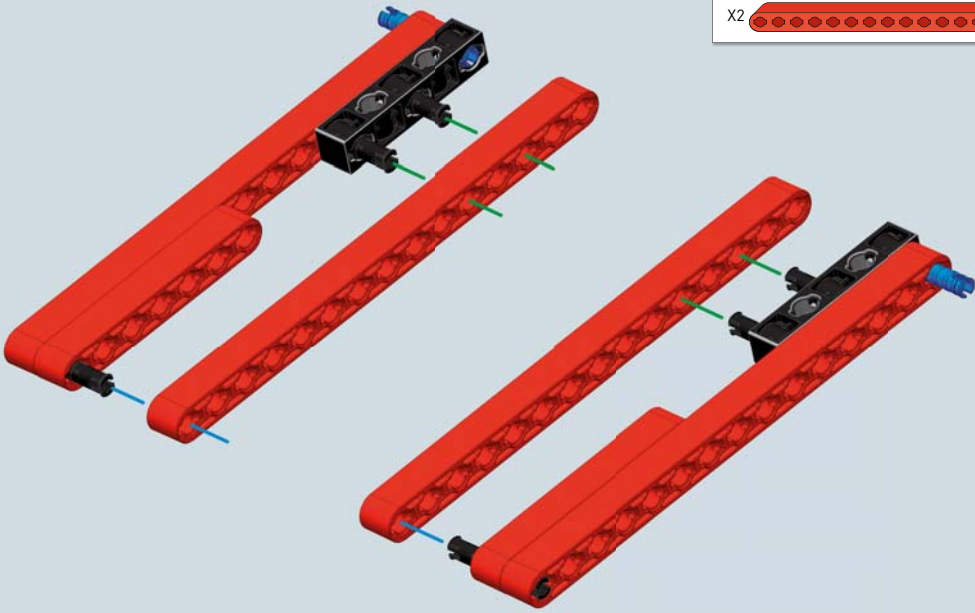

45

X2 



46

X2   
X1 

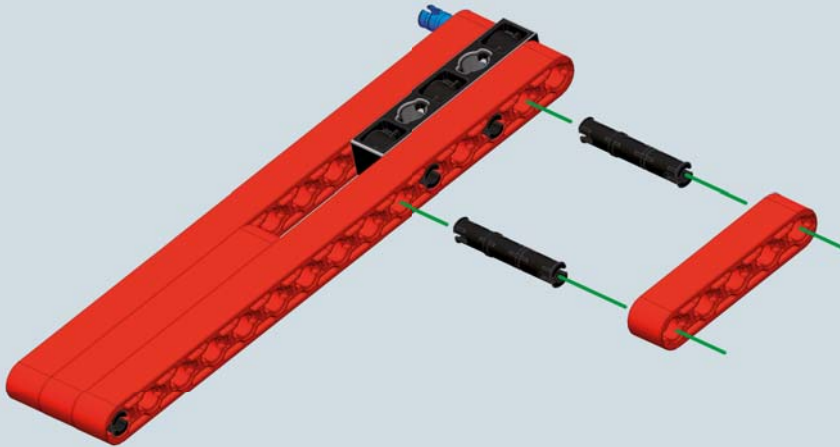

47

X1   
X1 



### Technische informatie en wetenswaardigheden

De meeste takelwagens zijn uitgerust met een vaste of kantelende laadvloer. Het kantelvlak wordt aangedreven door hydraulische cilinders die het omhoog heffen en doen kantelen.





48

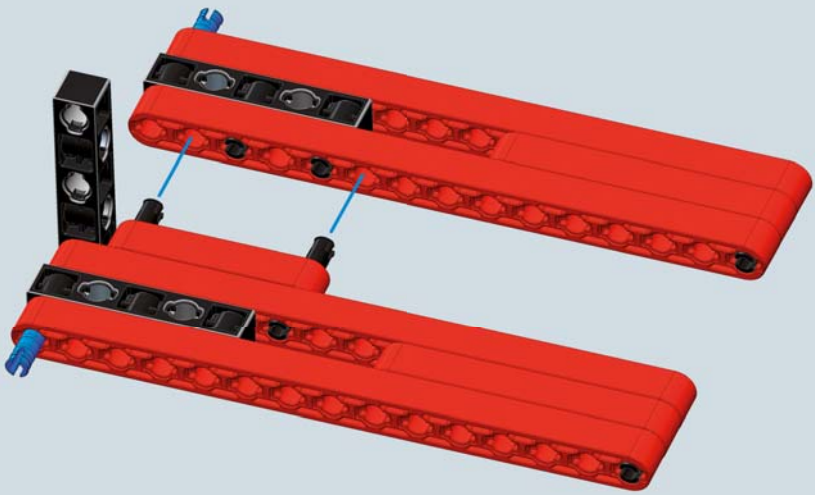

49

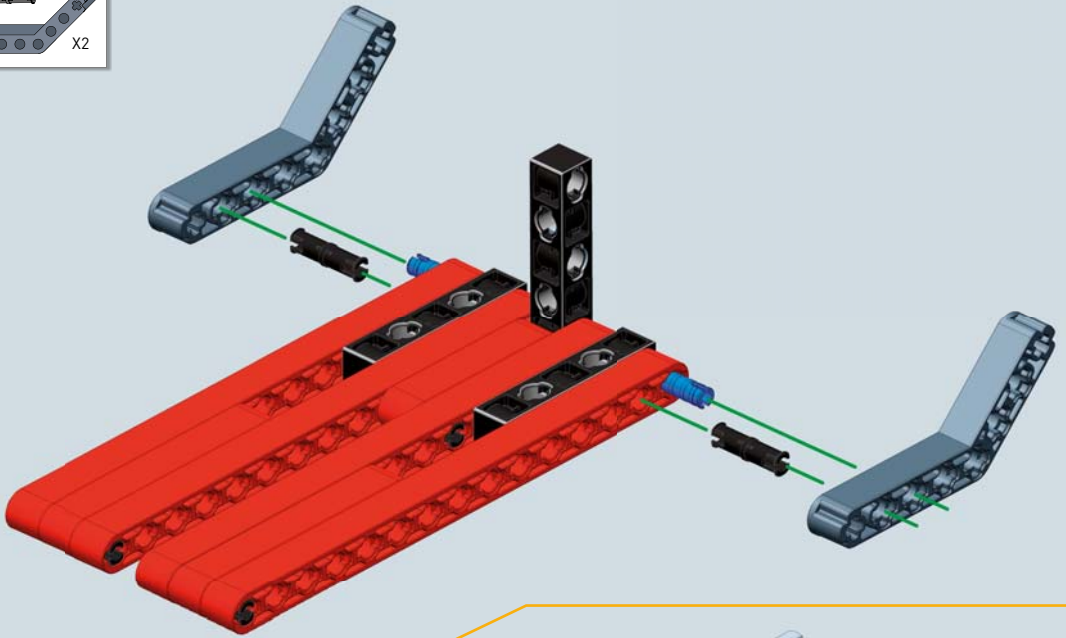
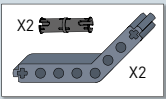

50

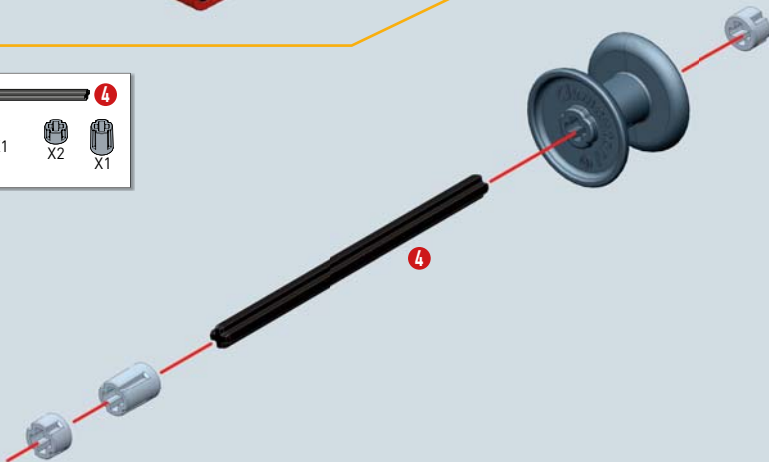
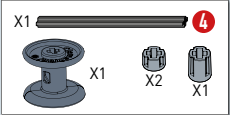

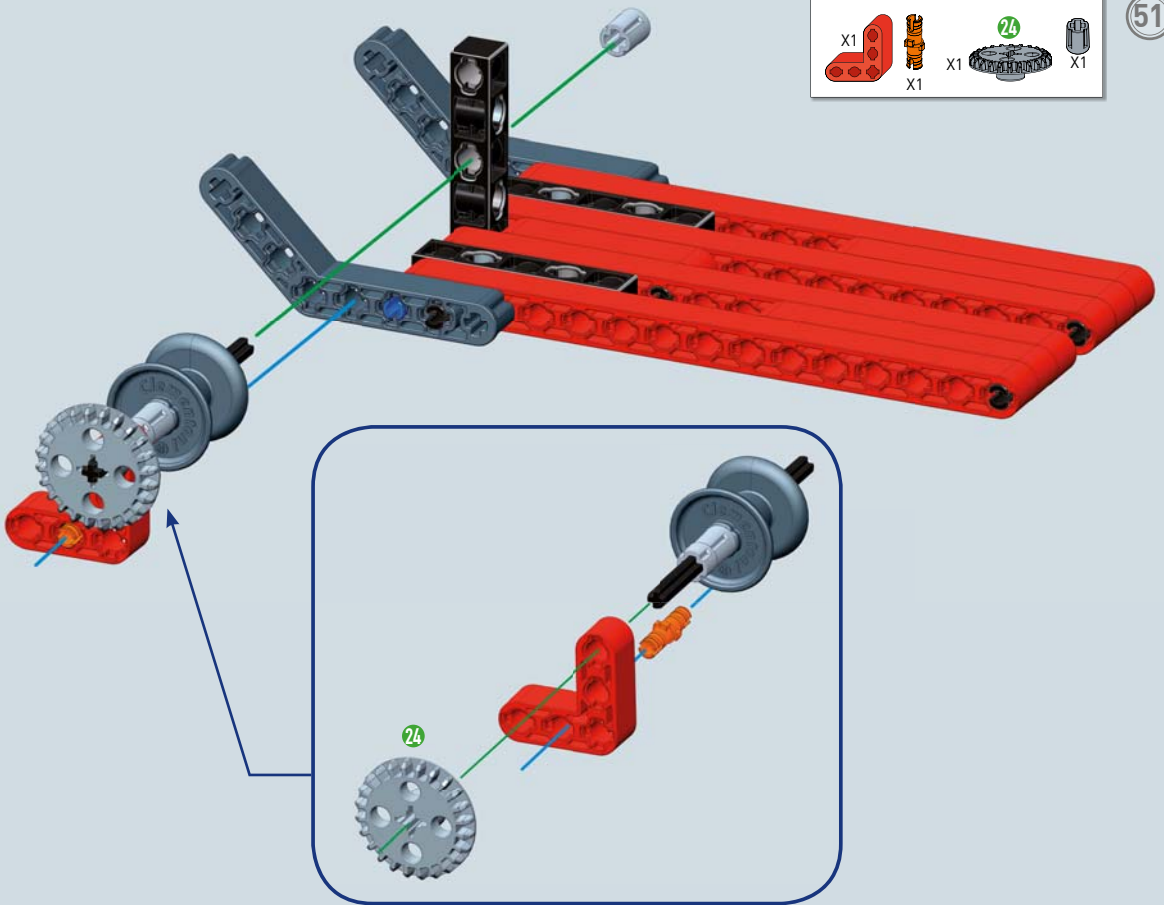

### Technische informatie en wetenswaardigheden

De lier is een onmisbaar element om het te takelen voertuig op de takelwagen te laden. Dit is een eenvoudig toestel dat gebruikt wordt om zware voorwerpen te slepen. Dankzij de krachtige stalen kabels kunnen de lieren, gemonteerd op de takelwagens gewichten van ongeveer 5500 kg slepen.

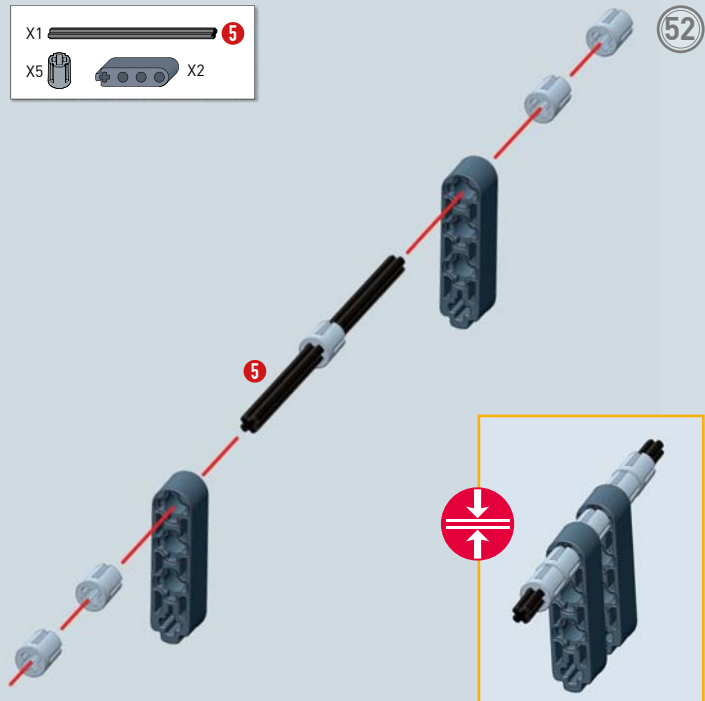
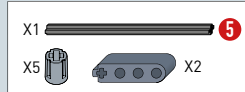

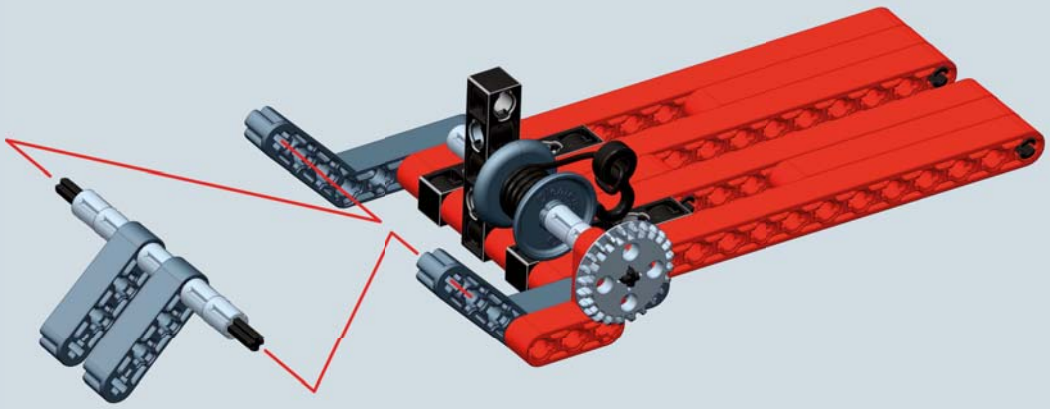

53

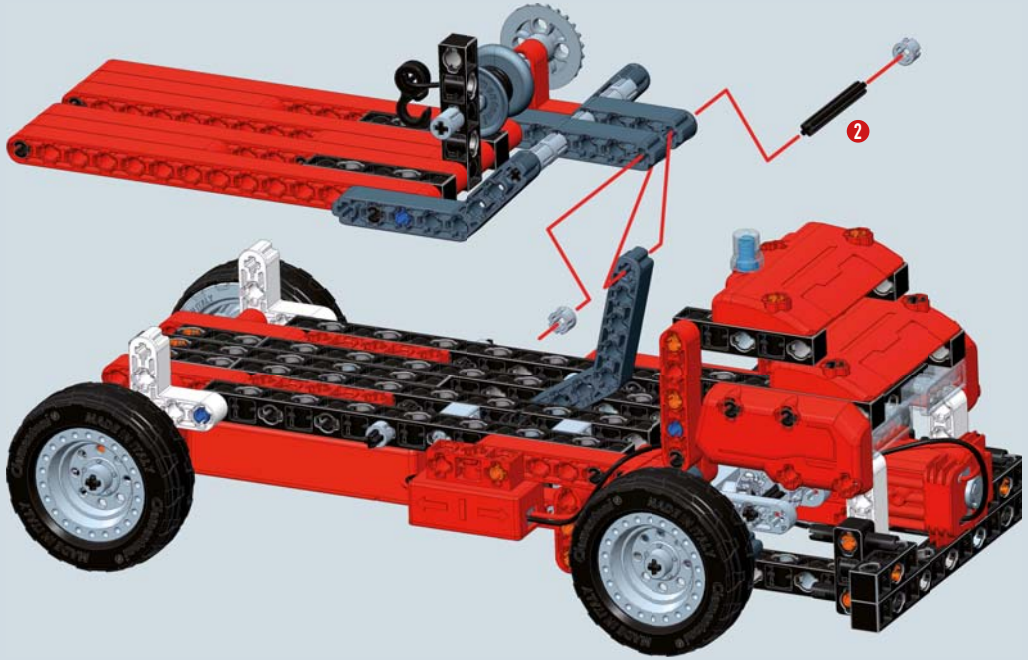

54



X2  X1  2

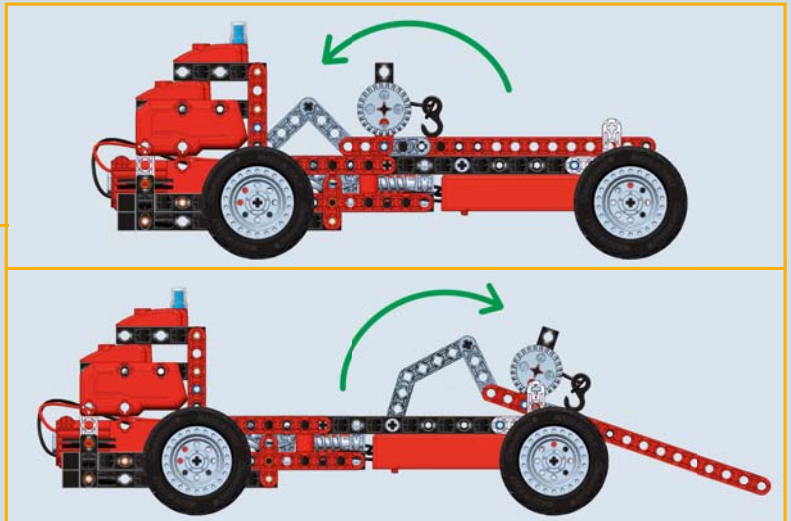

Met de schakelaar kan je het kantelvlak activeren.

1:1  2