

MECHANICS  
Laboratory

Constructions 1 to 11

2-speed  
GEARBOXGear  
RACK

- 1 - The first car in the world
- 2 - A vintage car with four seats
- 3 - Build a gear rack
- 4 - Assemble a manual gearbox
- 5 - Car with gearbox and electric motor
- 6 - Lunar buggy
- 7 - Assemble a scooter
- 8 - Build a motorbike
- 9 - Dragster with electric motor
- 10 - Livestock lorry
- 11 - Play music with a Celtic harp

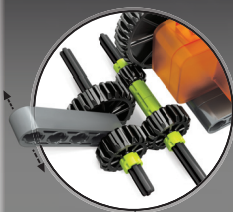
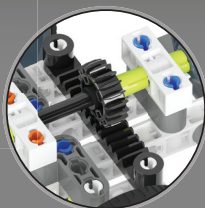

## WARNING

In order to ensure correct function of the electric motor, a small quantity of grease is added during the manufacturing process. As grease can melt at high temperatures, it may dirty the motor. However, it can simply be wiped off with a piece of kitchen paper or a napkin. The grease used is neither toxic nor hazardous.



## WARNING!

Only for use by children aged 8 years and older. Instructions for parents are included and have to be observed.

Read and keep this booklet for future reference.

Clementoni S.p.a.

Zona Industriale Fontenoce, s.n.c. - 62019 Recanati (MC) - Italy  
Tel. +39 071 75 811 - Fax +39 071 75 81234 - [www.clementoni.com](http://www.clementoni.com)

THE FUN CONTINUES ONLINE WITH  
ADDITIONAL ACTIVITIES TO DOWNLOAD  
New instructions to build models and learn more about  
the principles of physics and mechanics.  
[www.mechanicslaboratory.clementoni.com](http://www.mechanicslaboratory.clementoni.com)



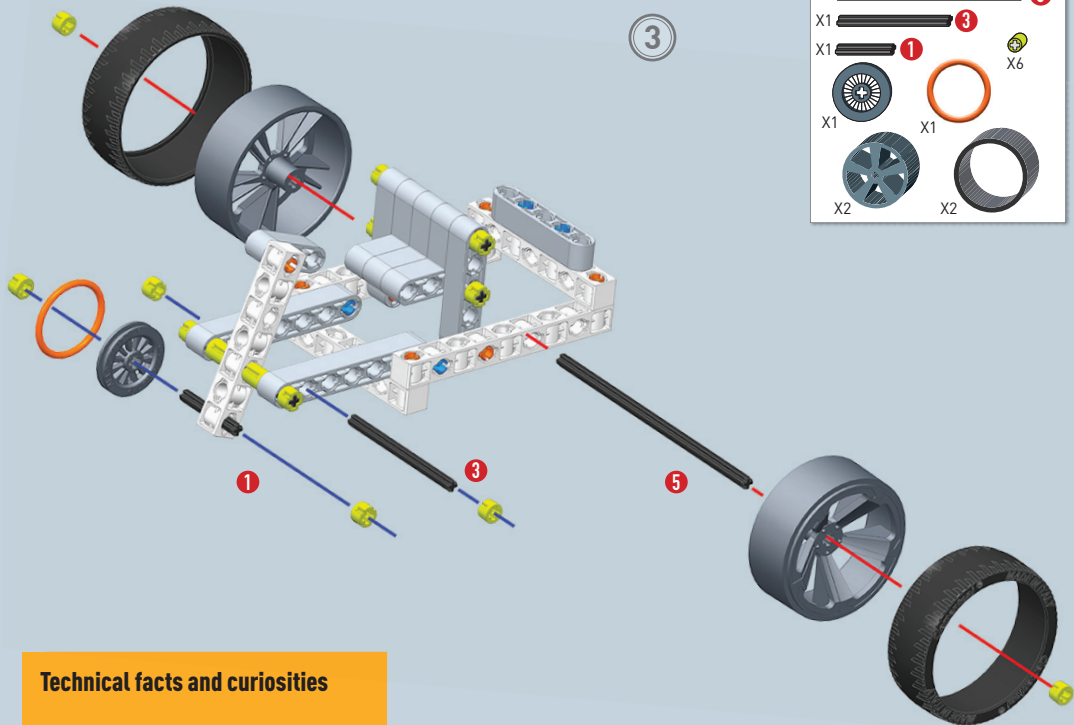

### Technical facts and curiosities

The first car in the world with a combustion engine was built in Germany by **K. Benz** in 1876. It was just under three metres long, weighed about 250 kg and could carry two people.

It had a single wheel at the front, like a tricycle, and a bar for steering, since a viable solution for moving two front wheels at the same time had not yet been devised.

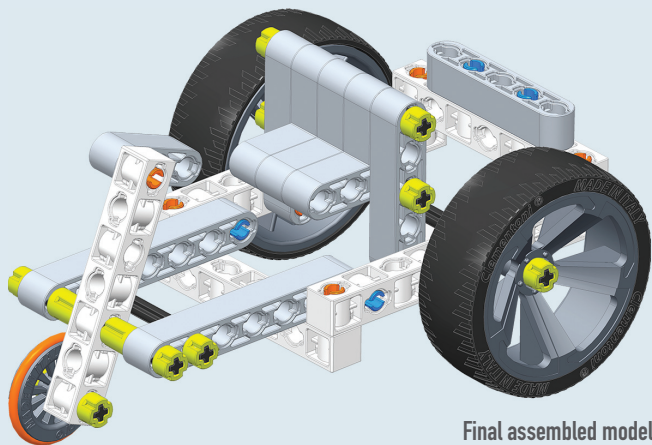

Final assembled model



## 2 A vintage car with four seats



1

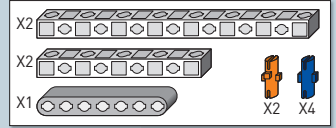
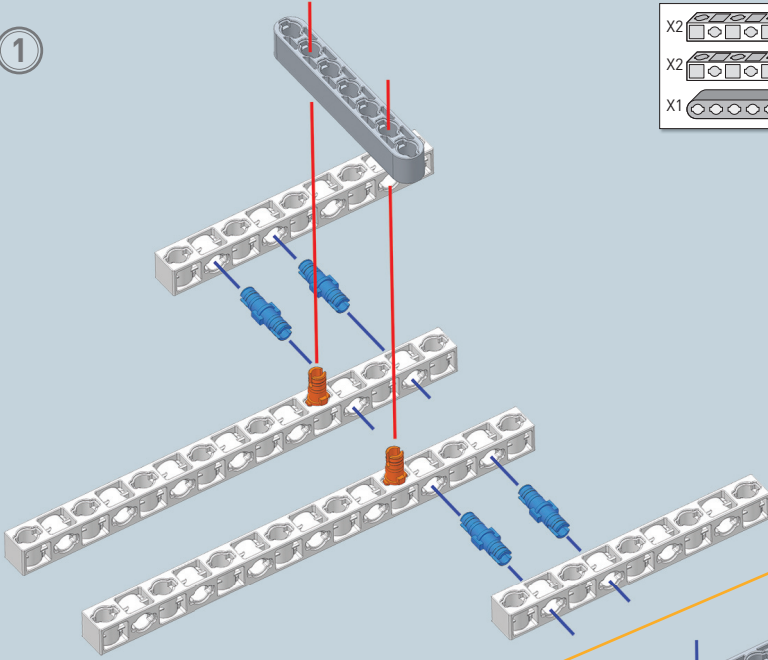

2

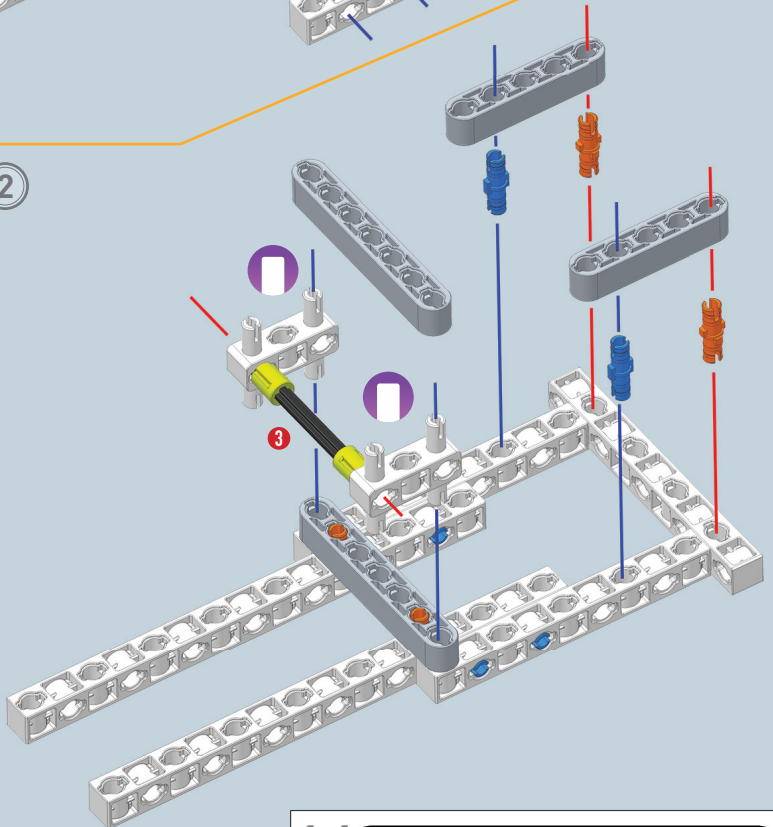
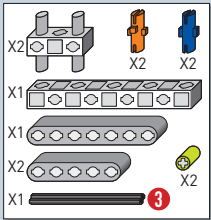

3

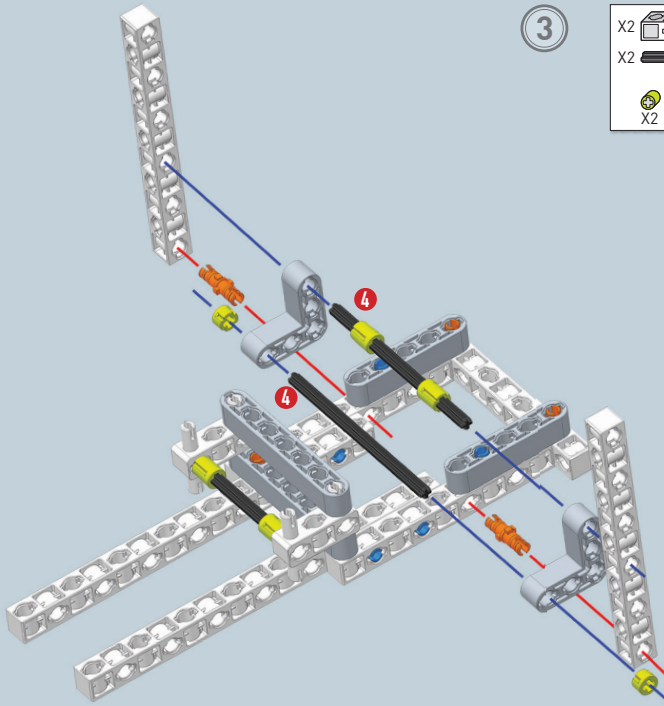
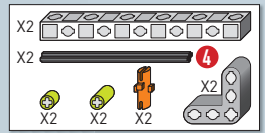

4

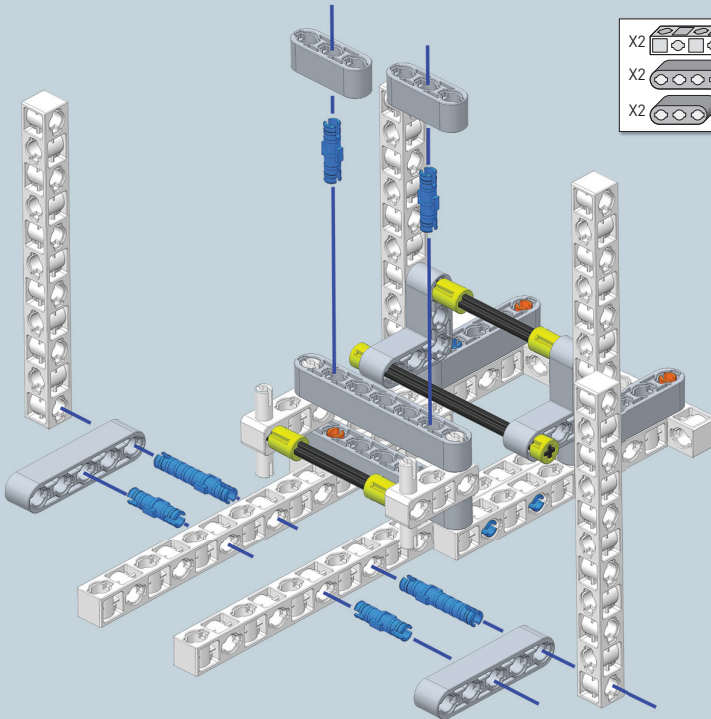
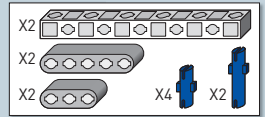

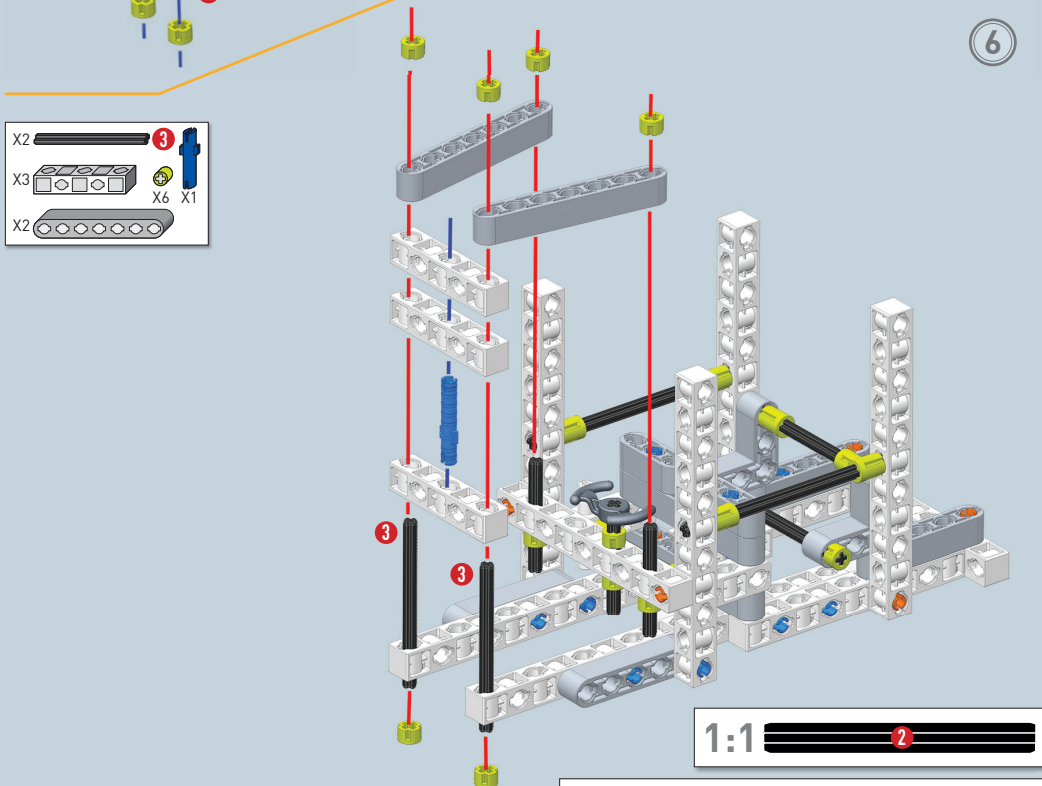
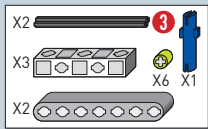
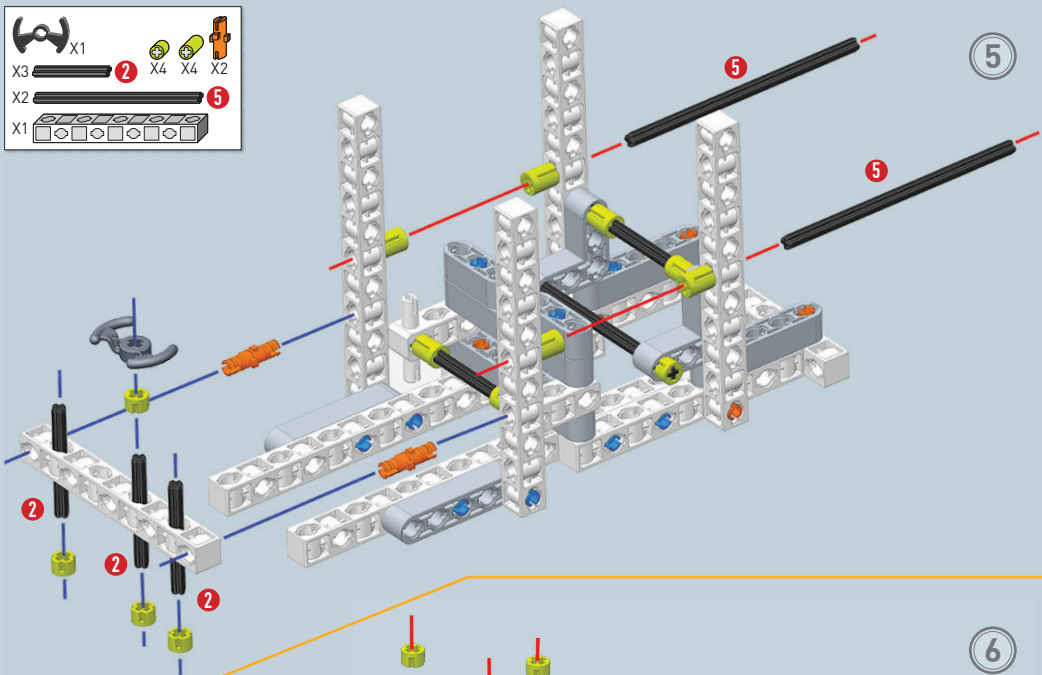
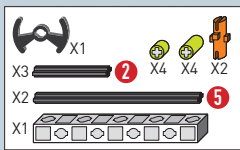

7

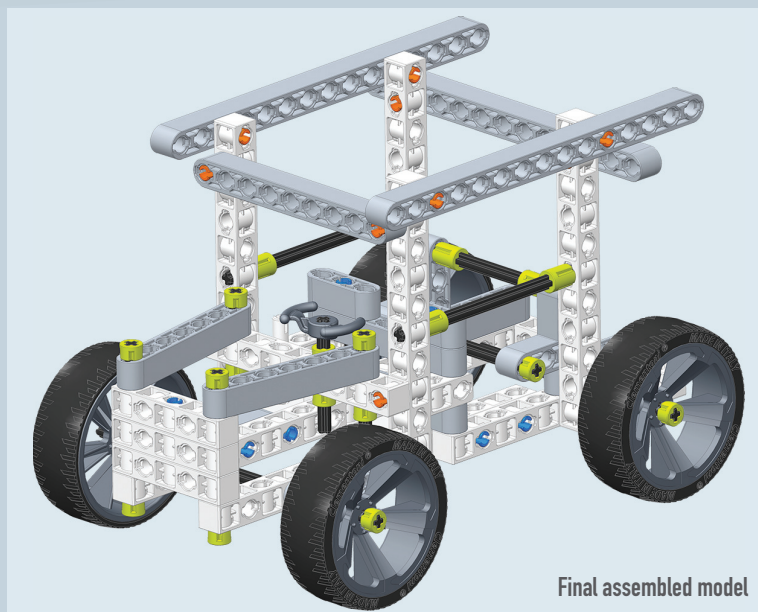
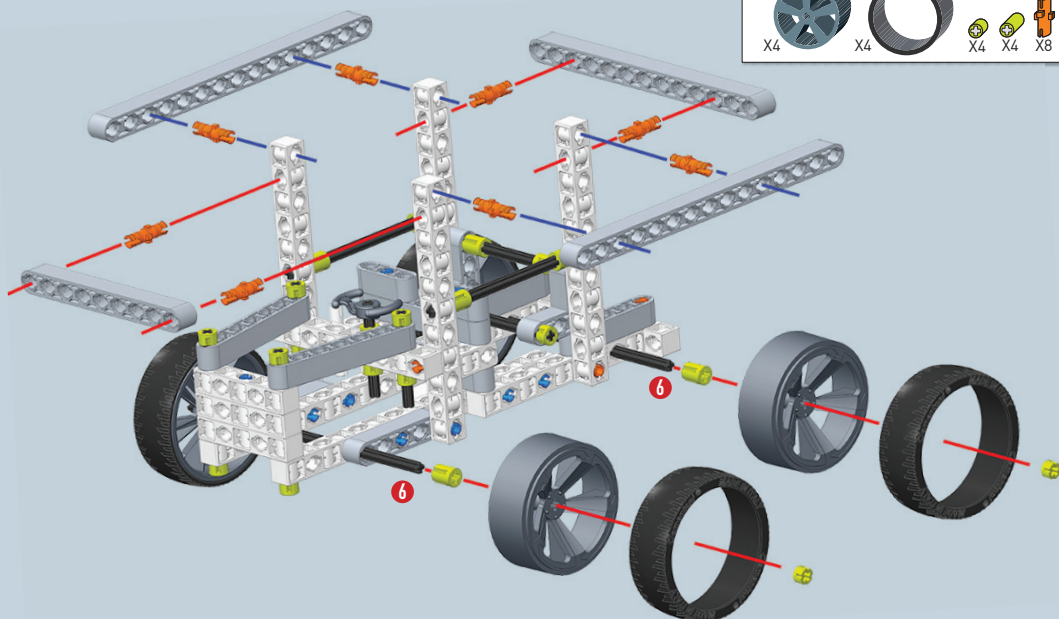
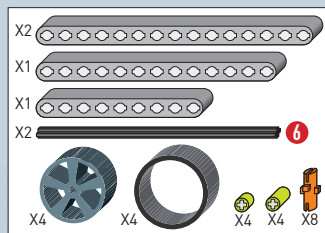

Final assembled model

1:1

6

### 3 Build a gear rack

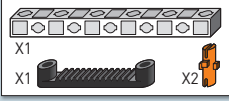

1

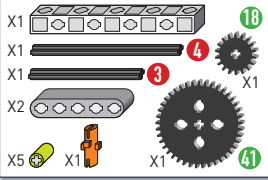
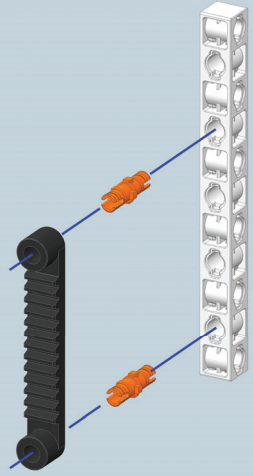

2

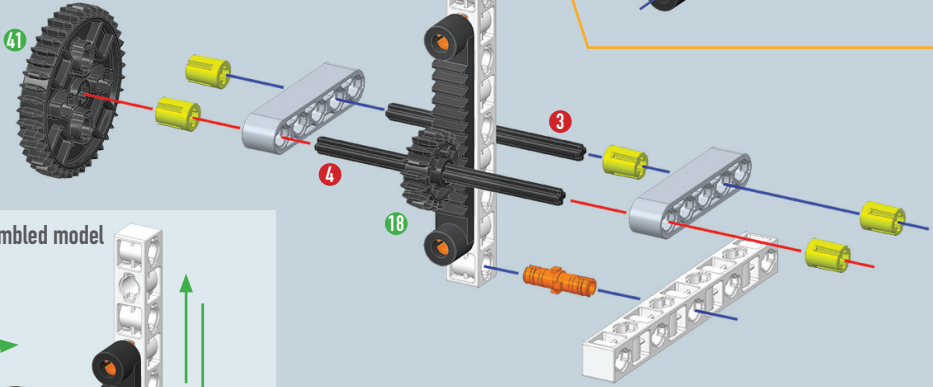

Final assembled model

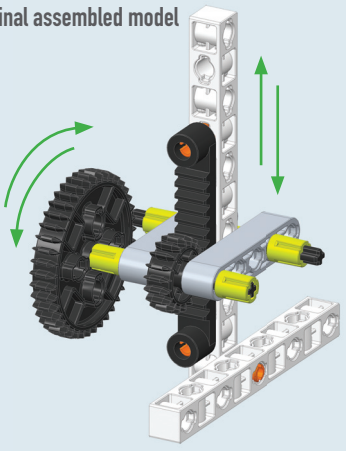

#### Technical facts about gear racks

A gear rack, together with a pinion, converts rotational motion into linear motion. In a car's steering system, the rotational motion of the steering wheel is converted into the linear motion of the wheels' tie rods, thus steering the car.

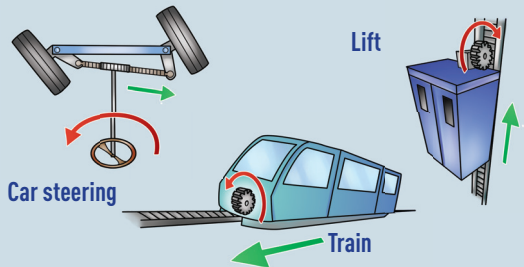



## 4 Assemble a manual gearbox

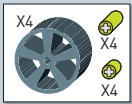
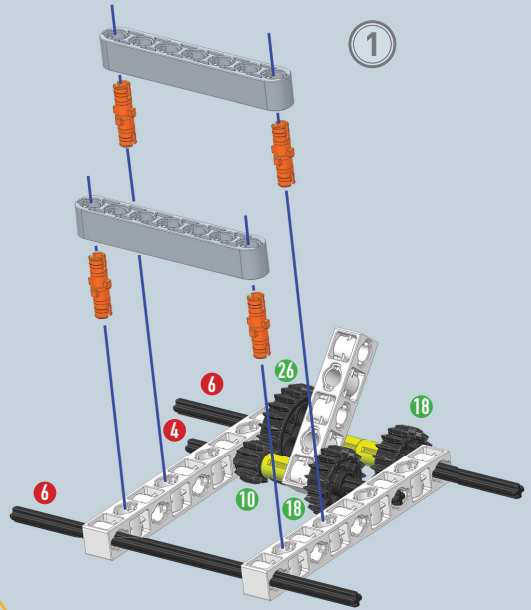
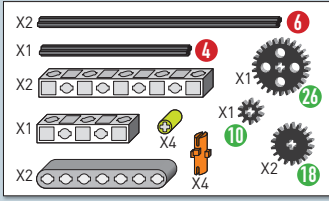

2

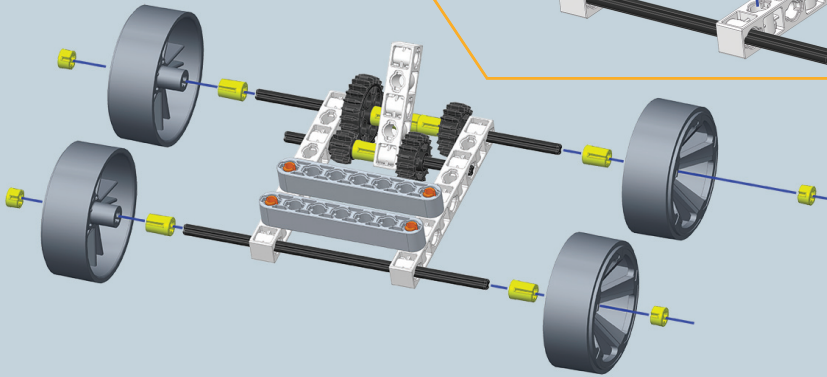

1:1



1:1

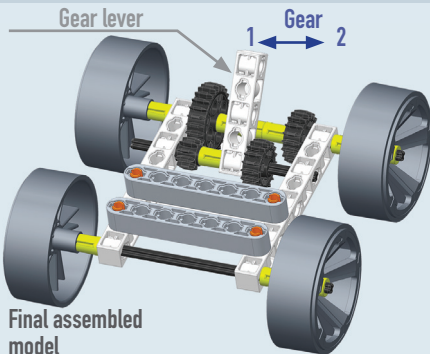

Final assembled model

### Technical facts on manual gearboxes

In a real car the gears are sealed inside a box, called the gearbox, which is positioned between the engine axle and the wheel axles.

### Ways of changing gear

The lever (see figure) can be used to move the various-sized cogwheels horizontally on the transmission axle to make them engage with the cogwheels on the wheel axles, which, depending on the driving wheel, causes a change in the rotation of the wheels and a change in the speed of the car.

# 5 Car with gearbox and electric motor

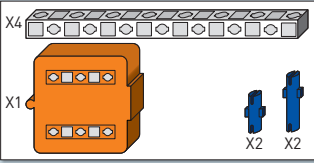

1

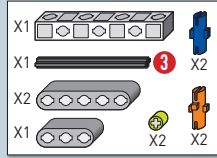
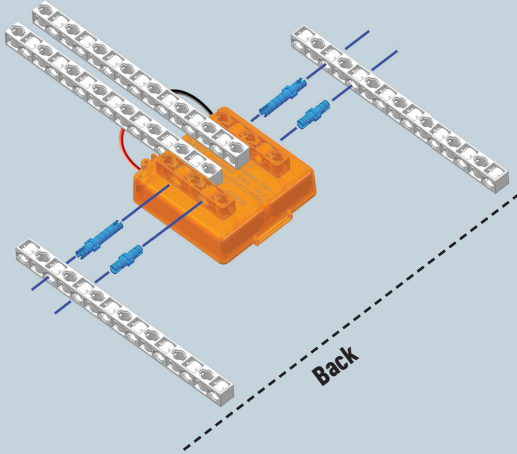

2

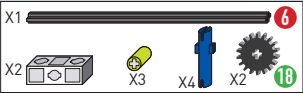
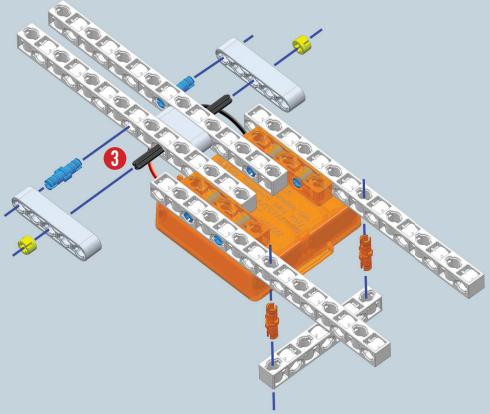

3

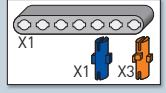
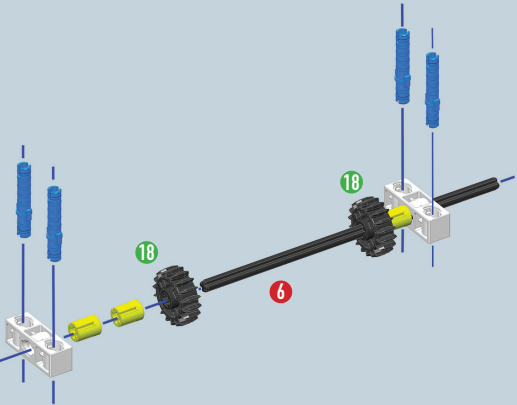

4

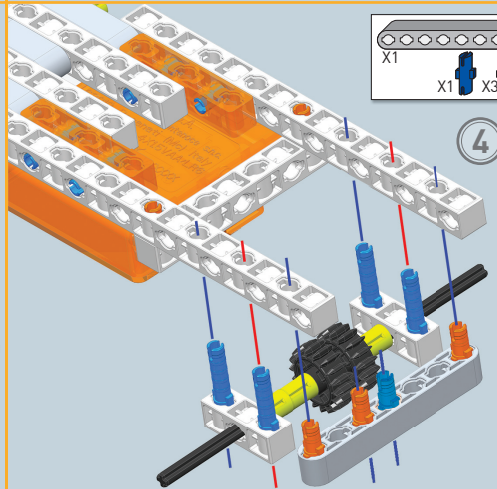

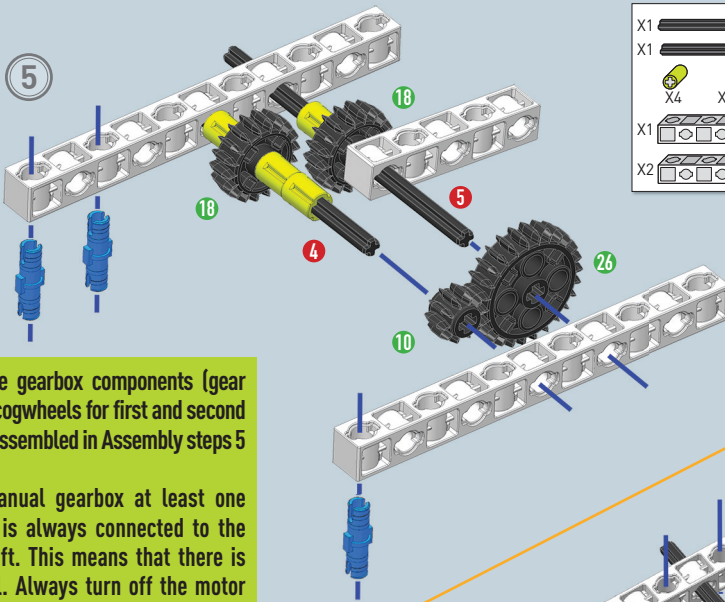

- X1 5
- X1 4
- X4 6
- X3 3
- X1 1
- X2 18
- X1 26
- X2 18
- X1 10

**Note** - The gearbox components (gear lever and cogwheels for first and second gear) are assembled in Assembly steps 5 and 6.

In this manual gearbox at least one cogwheel is always connected to the motor shaft. This means that there is no neutral. Always turn off the motor to change gear.

**Warning!** Carefully check the position of the rods with respect to the sides of the car. The rods should stick out an equal amount on both sides.

**Engaging the gears**

In the final assembled model, to engage and lock 1<sup>st</sup> gear, move the gear lever to the orange peg and press gently on the gear lever. To move into 2<sup>nd</sup> gear, turn off the motor, lift the gear lever, move it to the blue peg and press gently on the gear lever. Restart the motor.

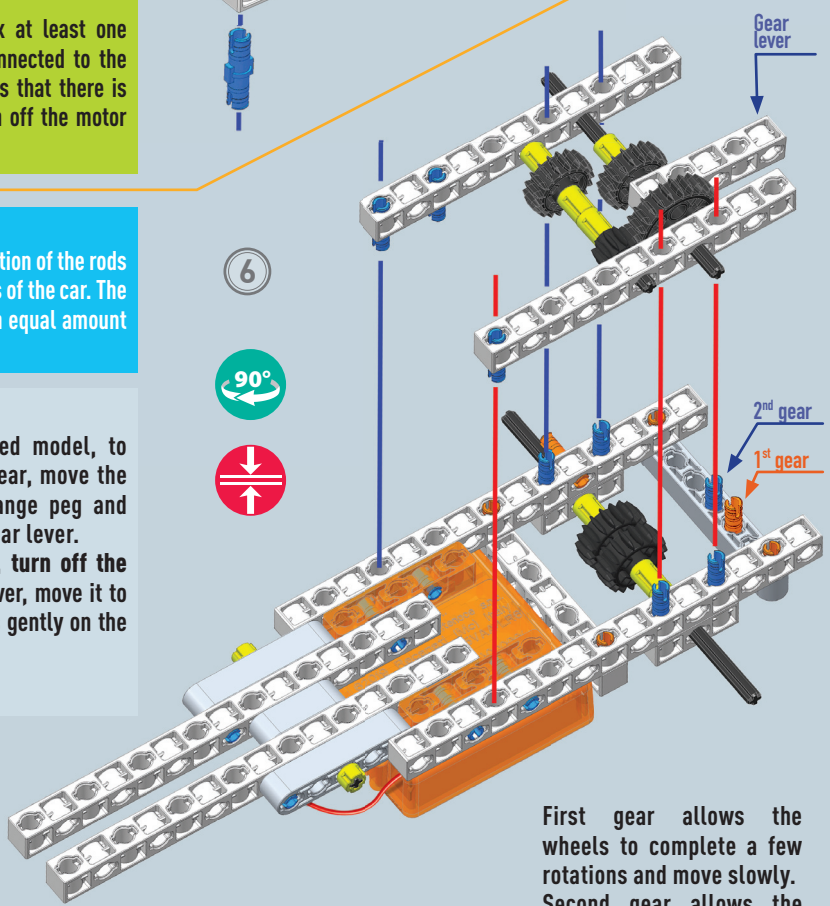

First gear allows the wheels to complete a few rotations and move slowly. Second gear allows the wheels to increase the number of rotations and therefore move faster.

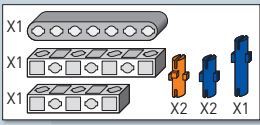

7

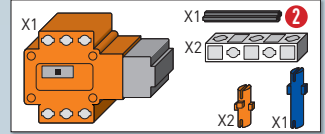
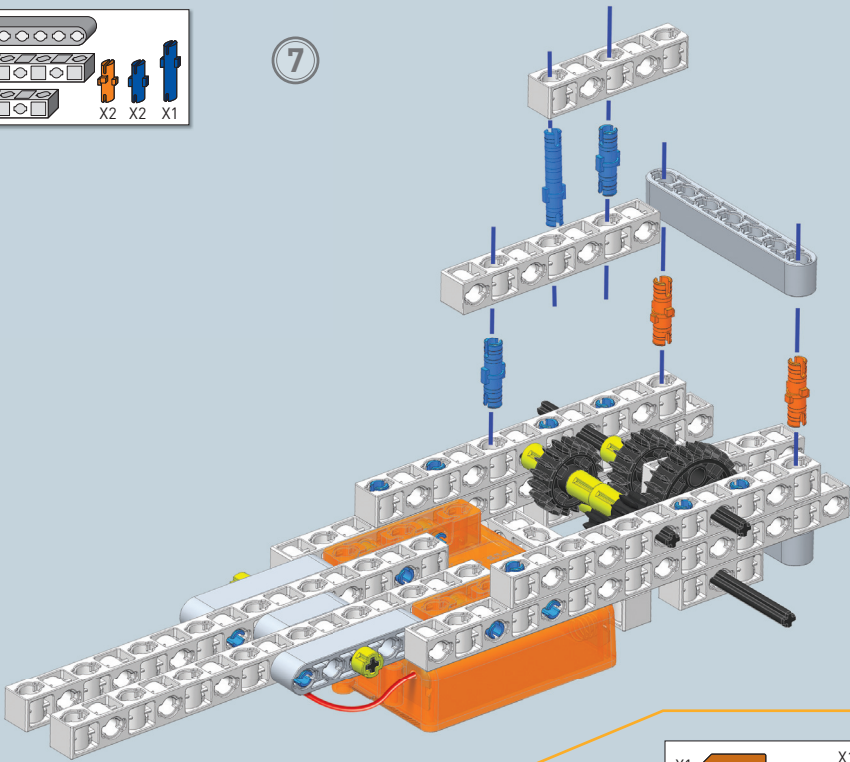

8

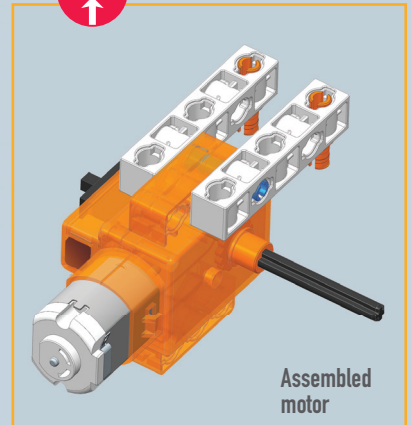
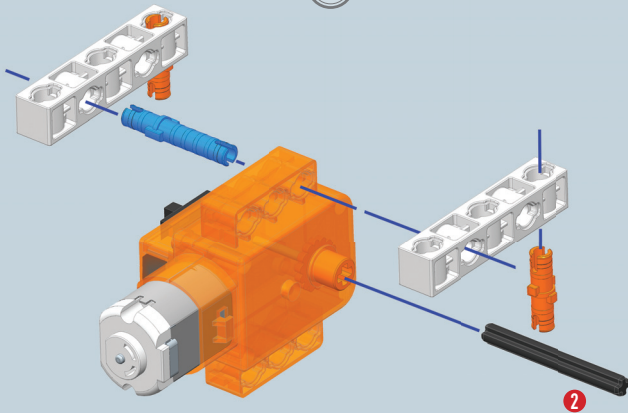

9

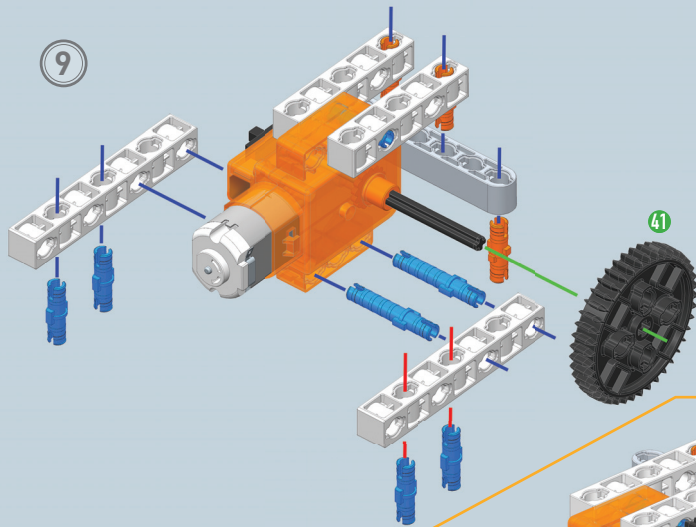

X1

X2

X1

X1

X2

X4

41

10

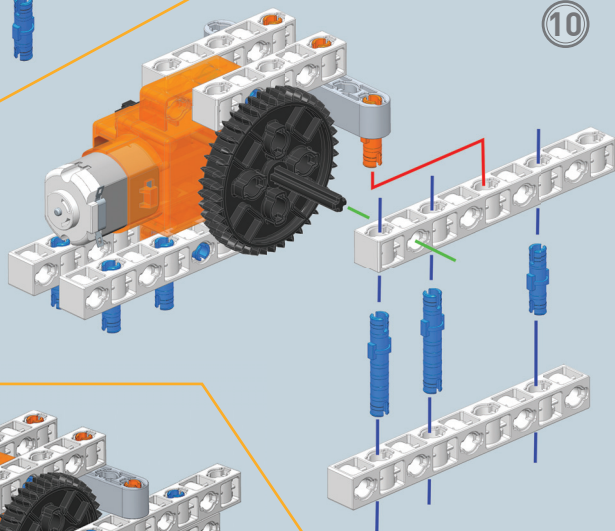

X2

X1

X2

11

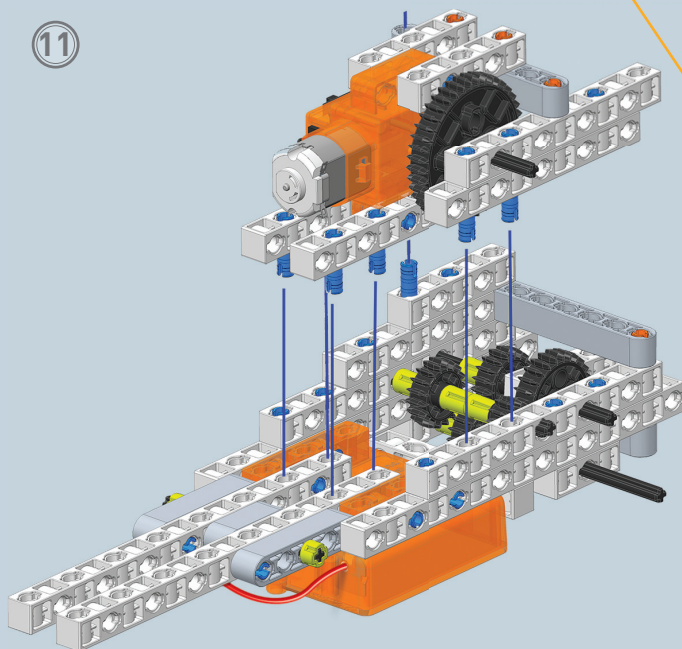

12

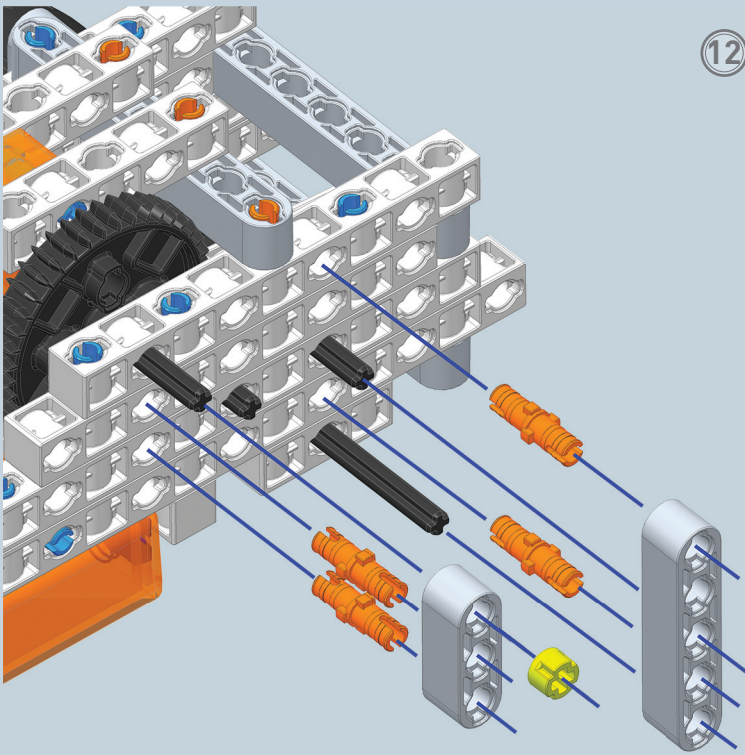

13

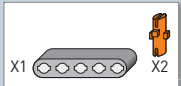

- With the motor switch in the central position (OFF), insert the Molex connector, making sure it is positioned correctly.

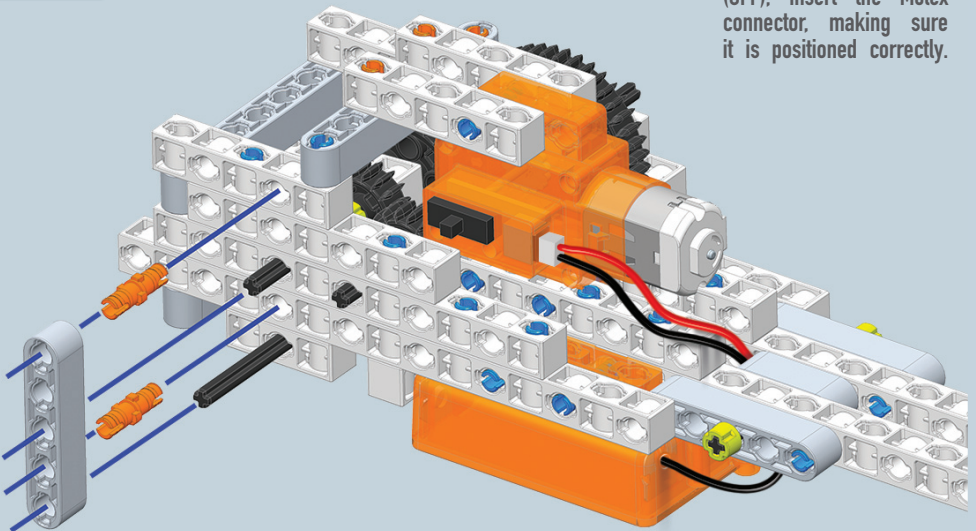

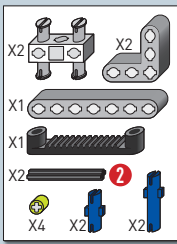

14

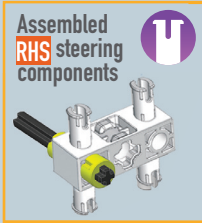

RHS

LHS

Note - The steering components (rods and collars) must be securely tightened.

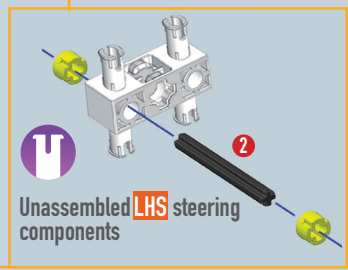

Unassembled LHS steering components

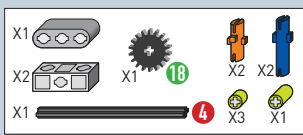

15

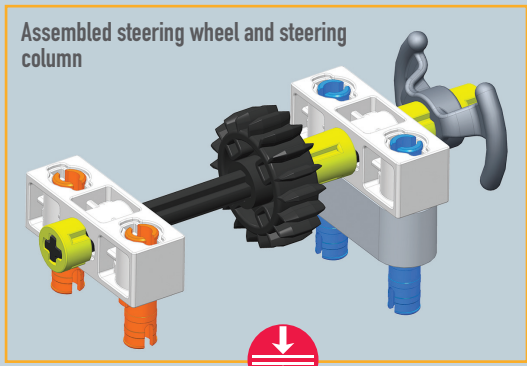
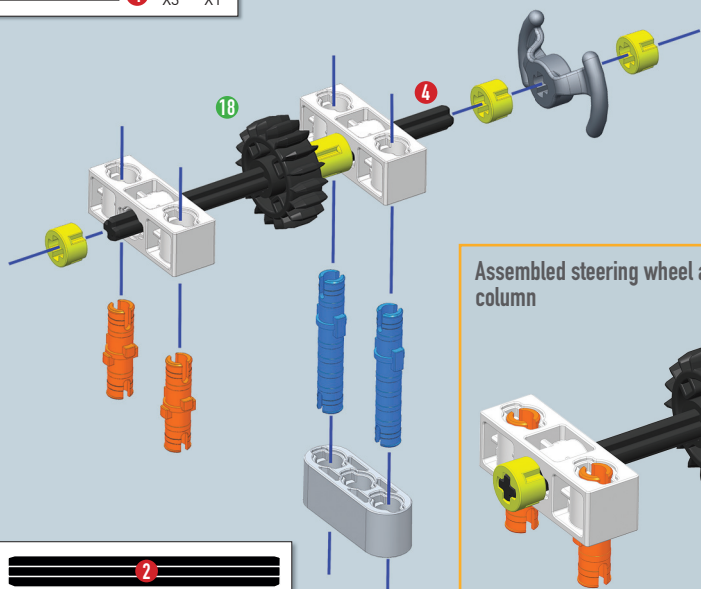

Assembled steering wheel and steering column



16

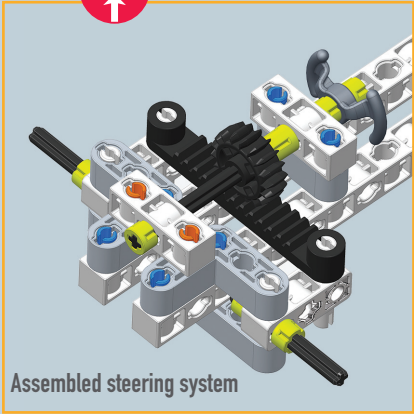

Assembled steering system

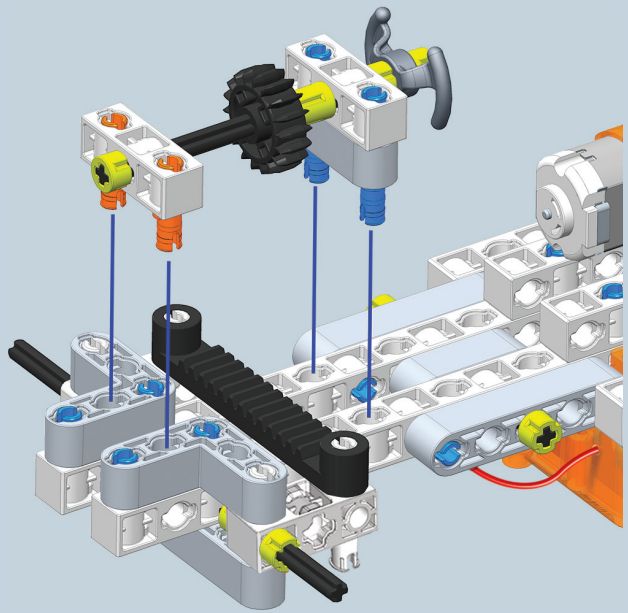

17

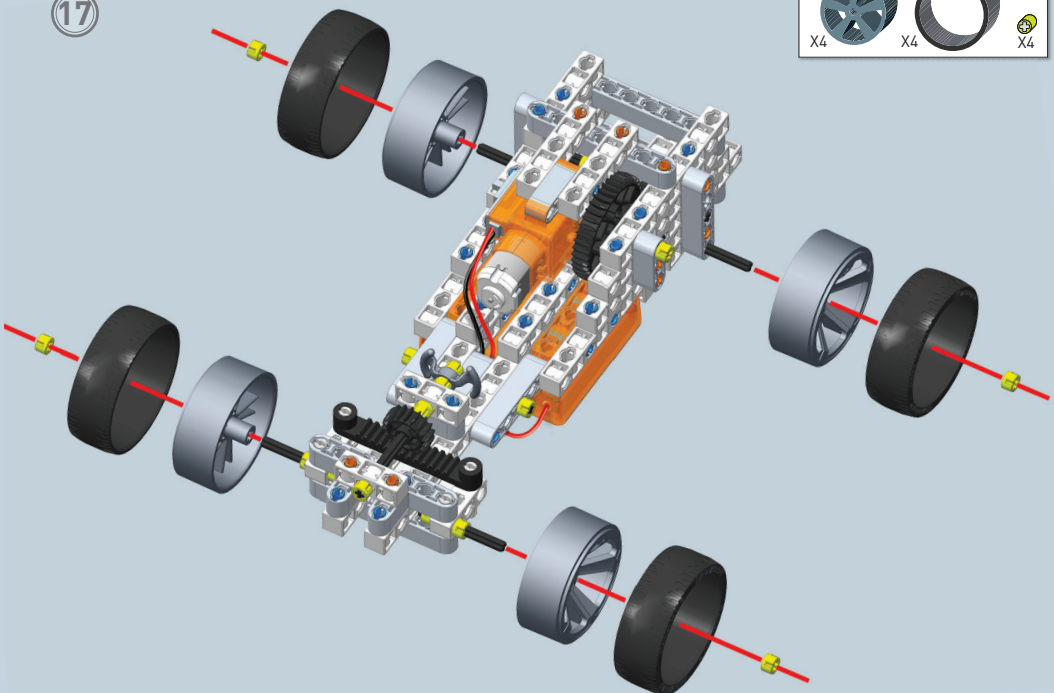
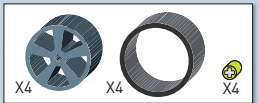



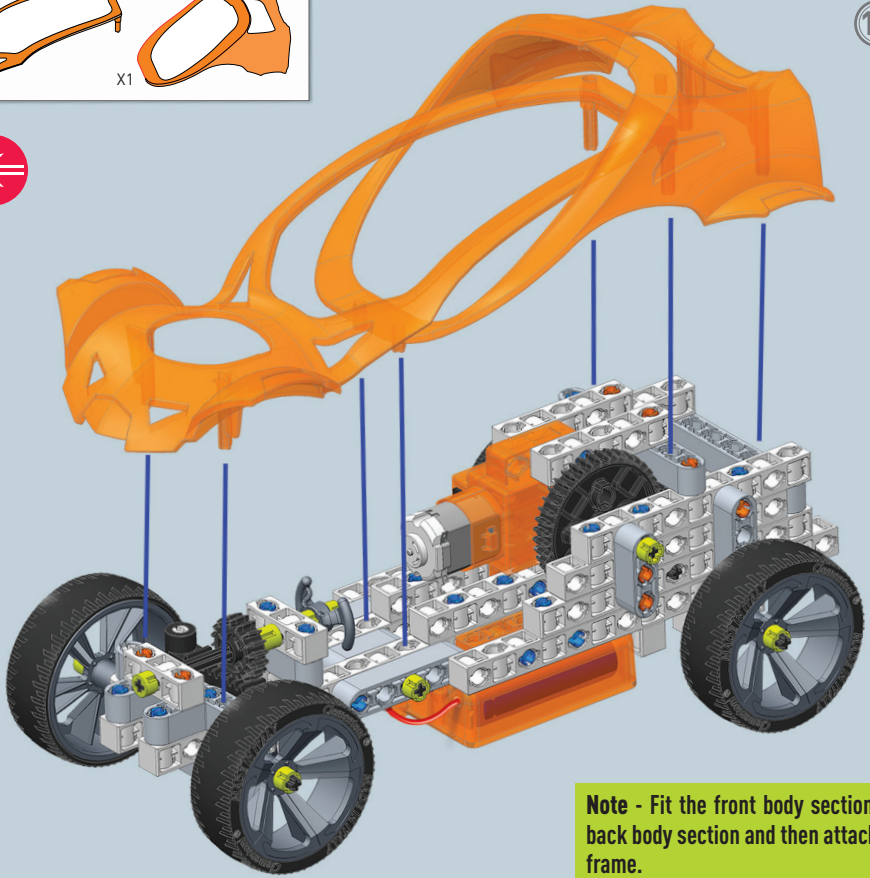
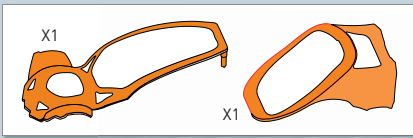

**Note** - Fit the front body section to the back body section and then attach to the frame.

**IMPORTANT!** Always turn off the motor to change gear.

- **Electric motor switch**  
Sliding the switch to the **central** position turns the motor **OFF**  
Sliding the switch to the **side** positions turns the motor **ON**

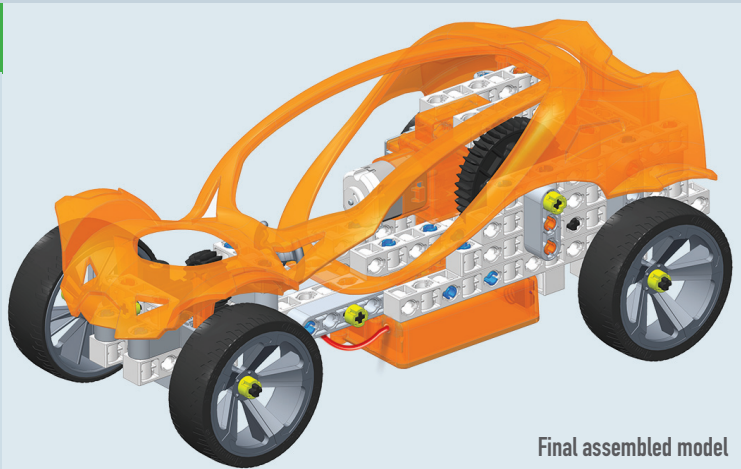
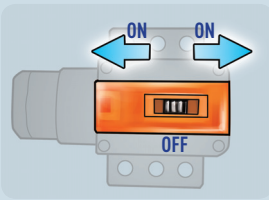

Final assembled model

**Note** - The car has a reverse gear, which can be accessed by operating the motor switch, and a two-speed gearbox.

# 6 Lunar buggy

1

X3		X2			
X2		X1			
X1		X1		X1	

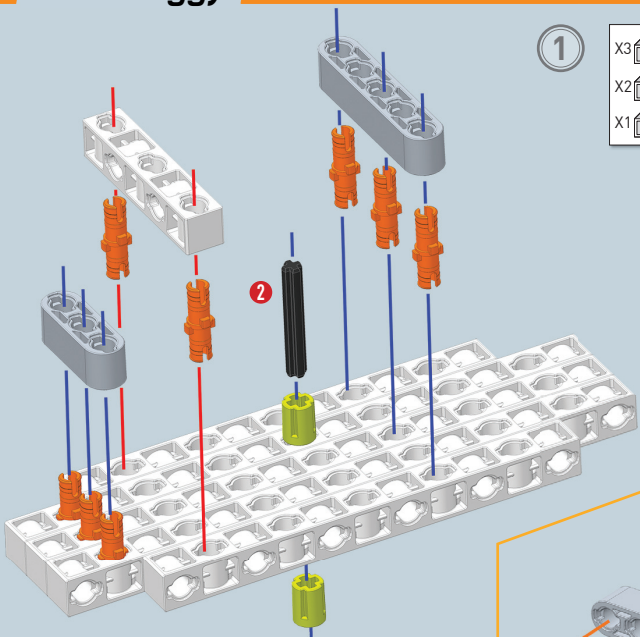

2

X2			
X1		X2	
X1		X2	

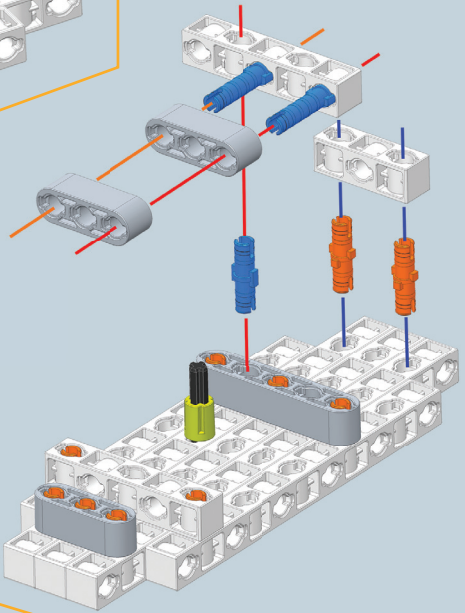

3

X2		
X4		

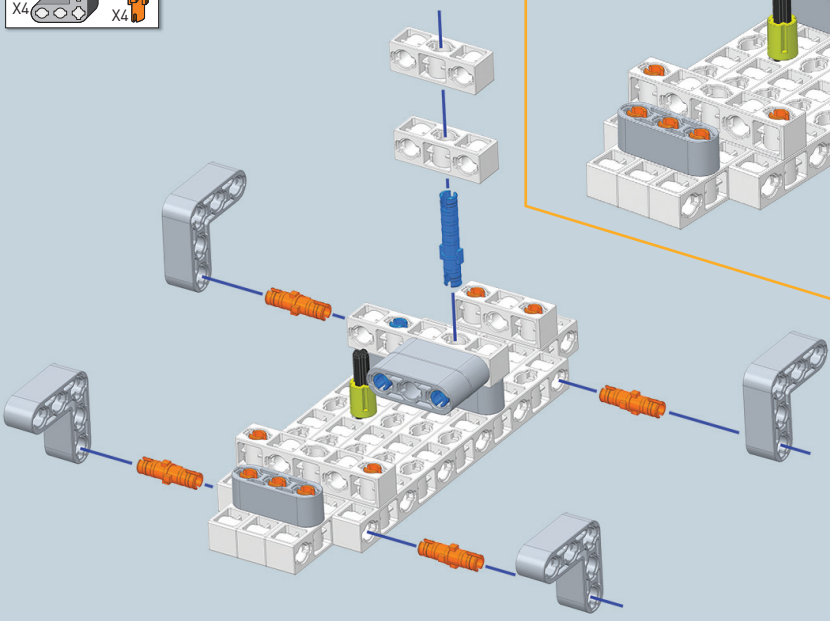

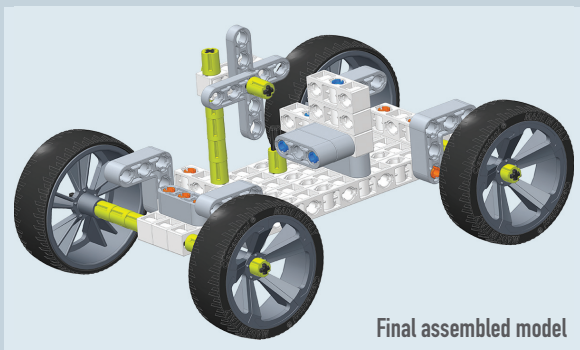
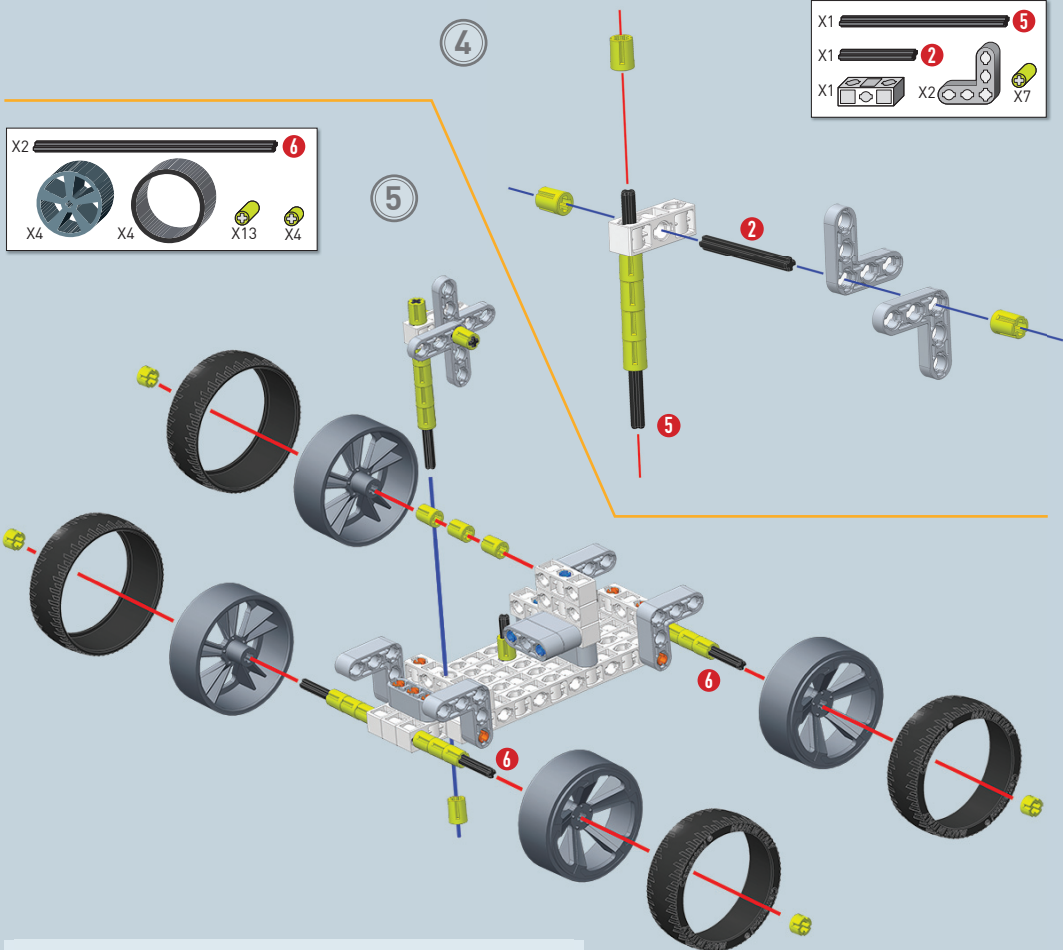

Final assembled model

**Technical facts and curiosities**

**1971** In the Apollo 15 moon mission, NASA, the US space agency, used the first car with an electric motor on the surface of the moon. It weighed 200 kg, had non-rechargeable chemical batteries and went about 5 km an hour. The buggy was abandoned on the moon.



# 7 Assemble a scooter

1

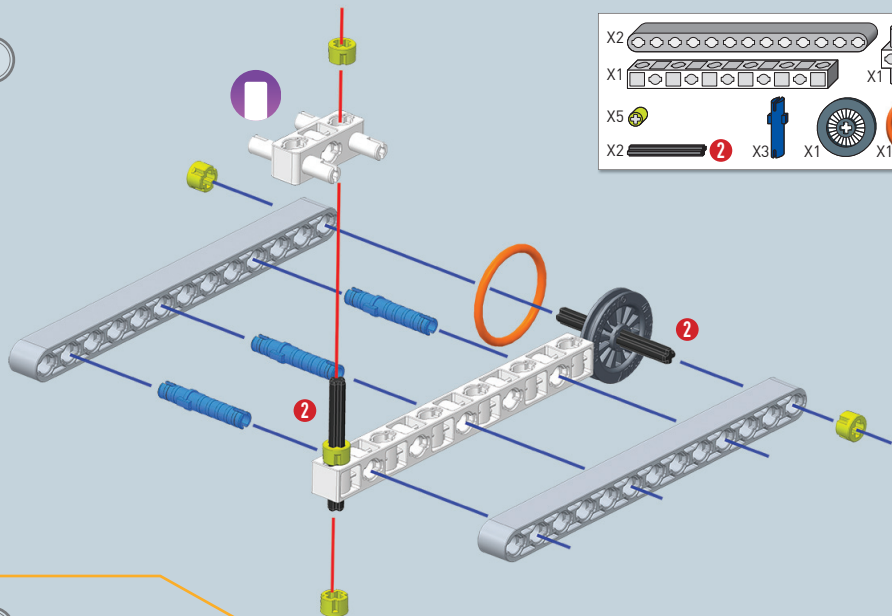

X2		
X1		
X5		
X2		
X3		

2

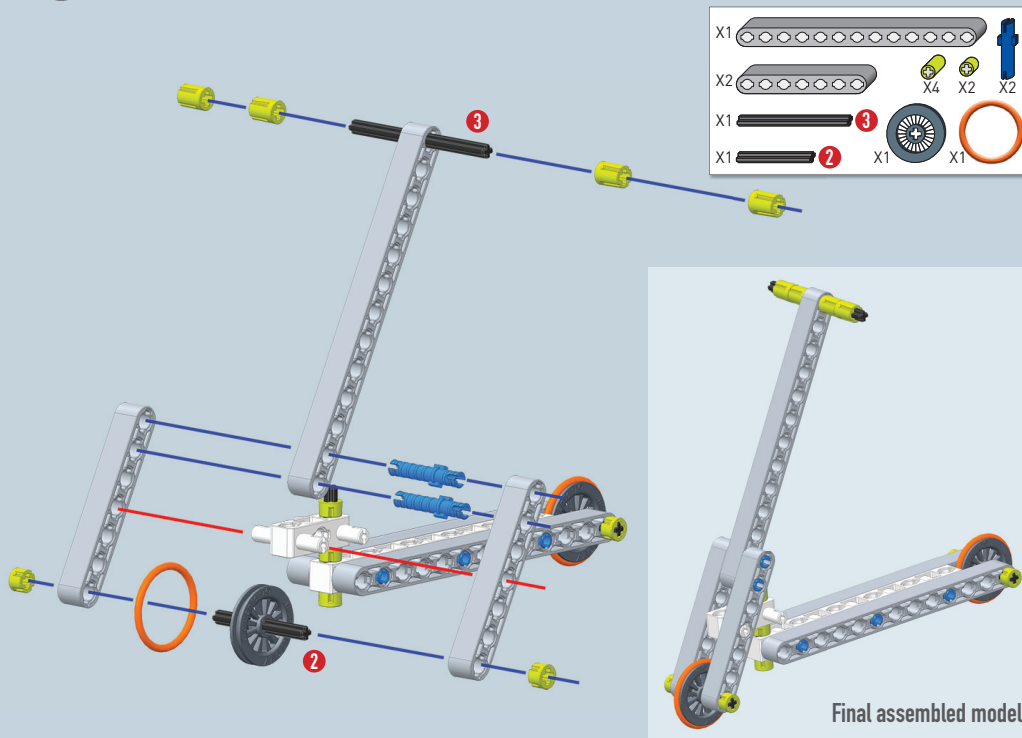

X1		
X2		
X1		
X1		
X4		
X2		

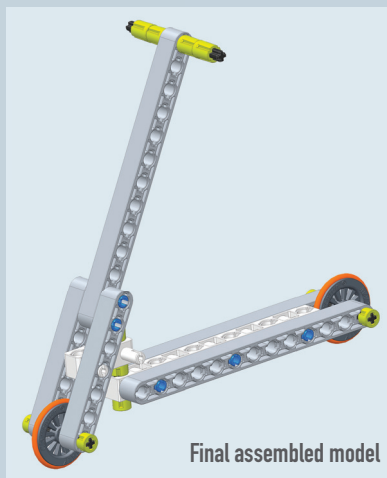

1:1

1:1



3

X1		4	
X1		3	X2
X2		X4	
X1		X1	
X1		X1	

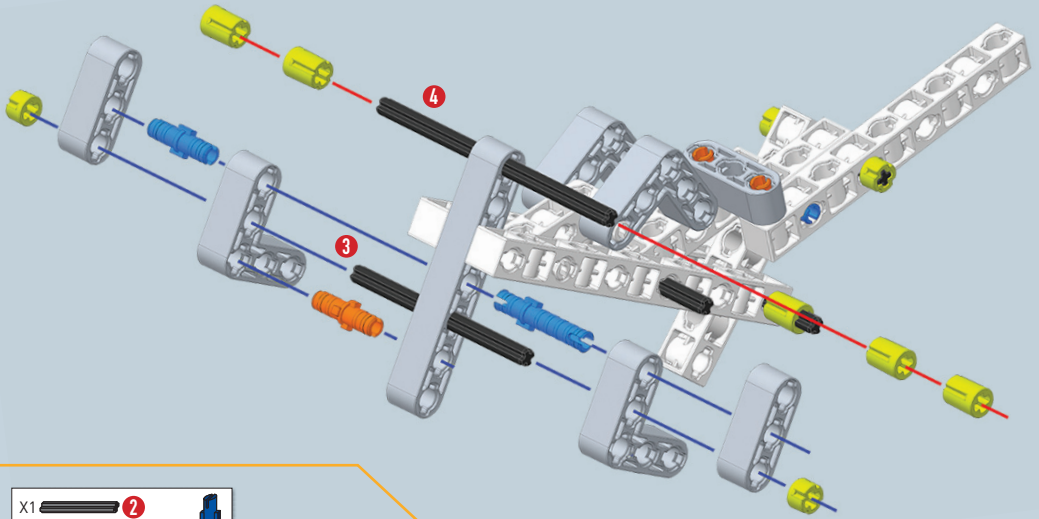

X1		2	
X2		X2	
X1		X1	

4

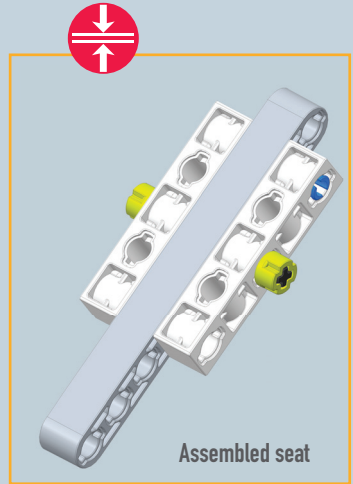
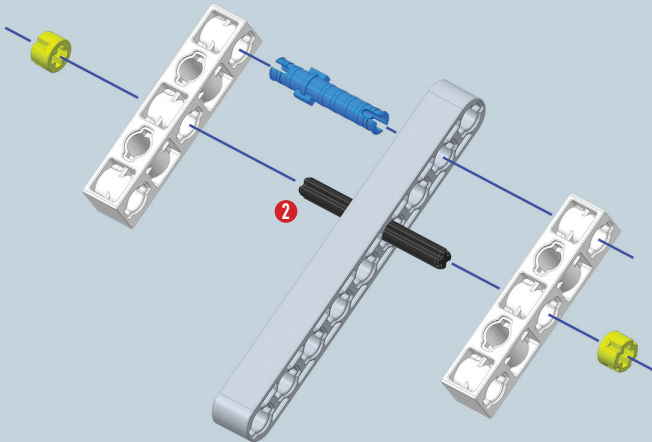

1:1

1:1

1:1

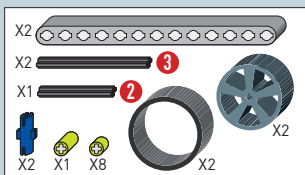

5

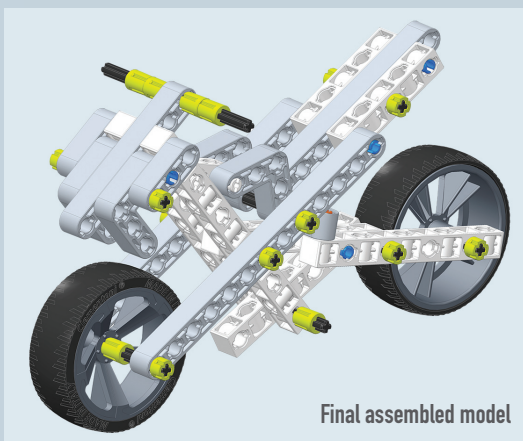
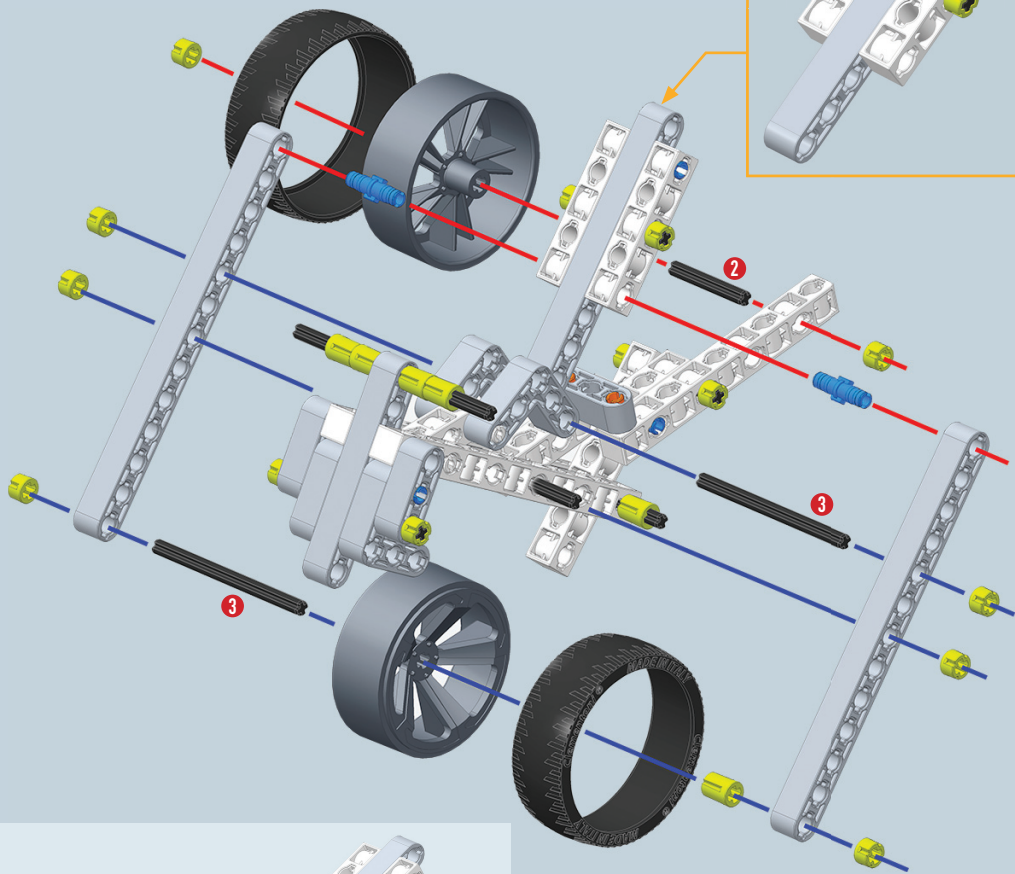

Final assembled model

### Technical facts and curiosities

1869 French engineer **L. G. Perreaux** filed a patent for a motorbike and built a two-wheeled vehicle with a steam engine, based on the bicycle.

1885 German engineers **G. Daimler** and **W. Maybach** built the first motorbike with a combustion engine. It had a wooden frame and wheels.









5

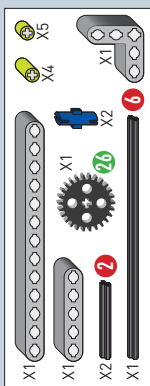
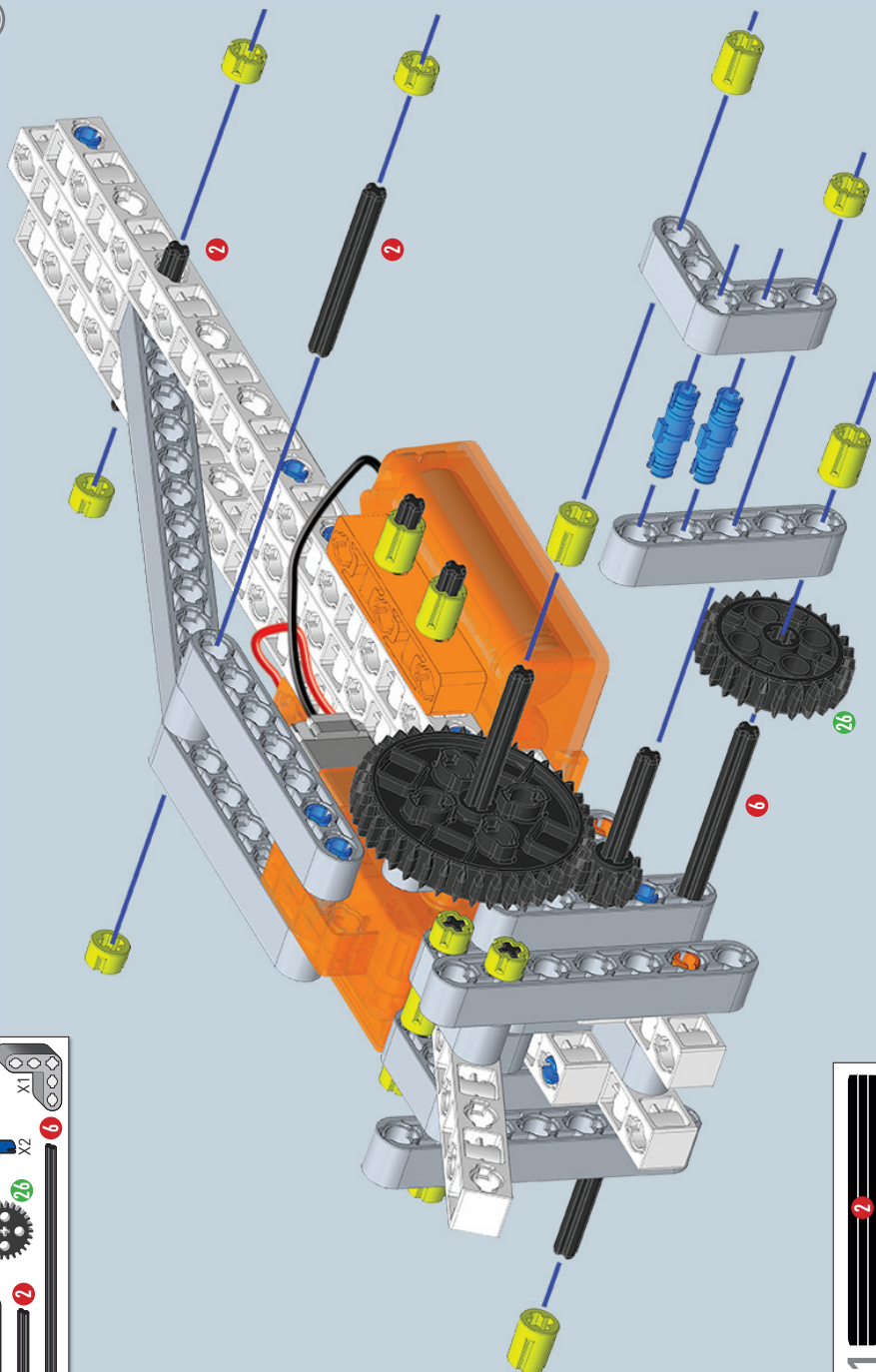



1

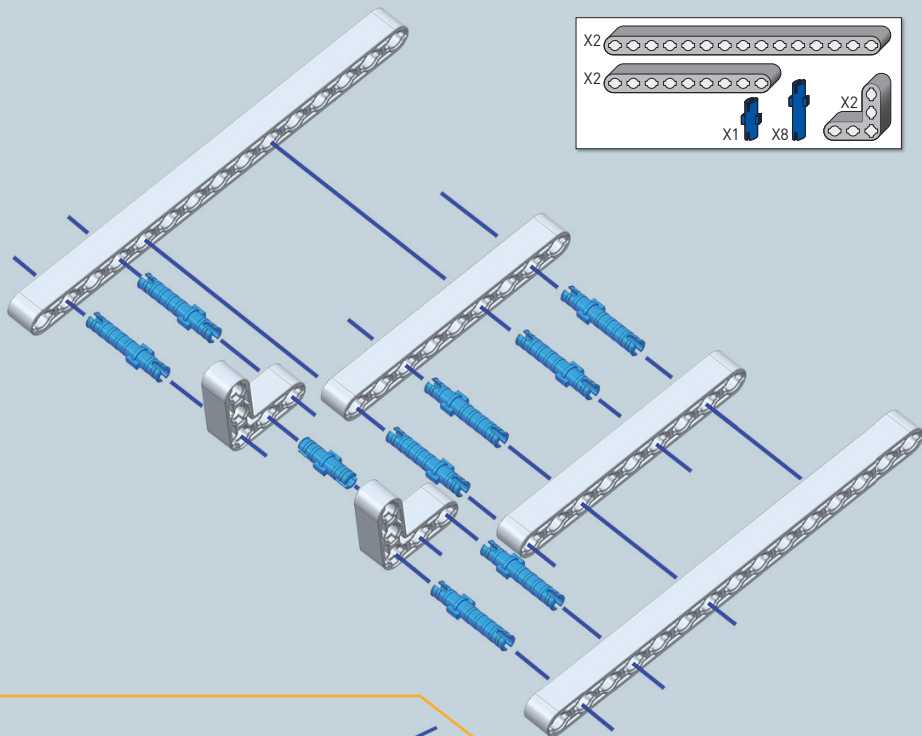

X2	
X2	
X1	
X8	
X2	

2

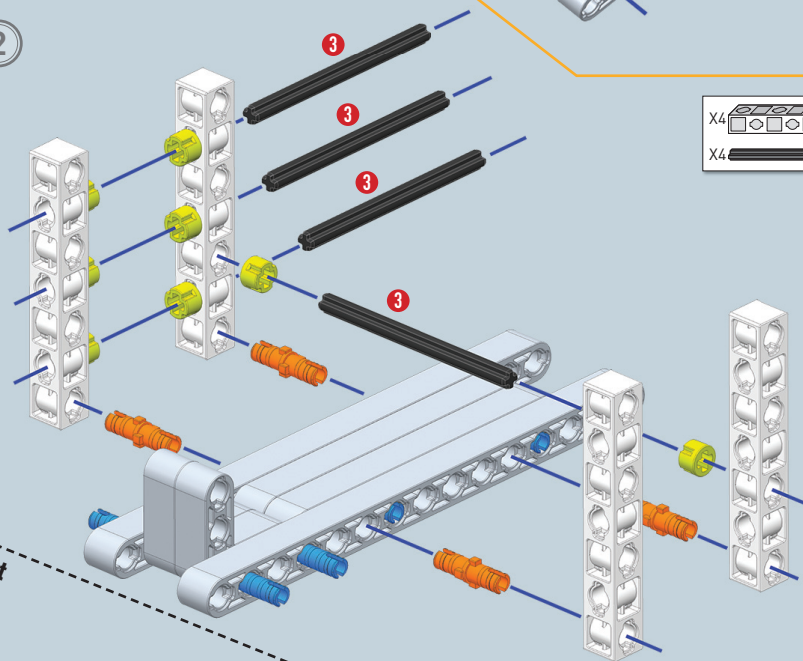

X4	
X4	
X8	
X4	

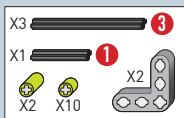

3

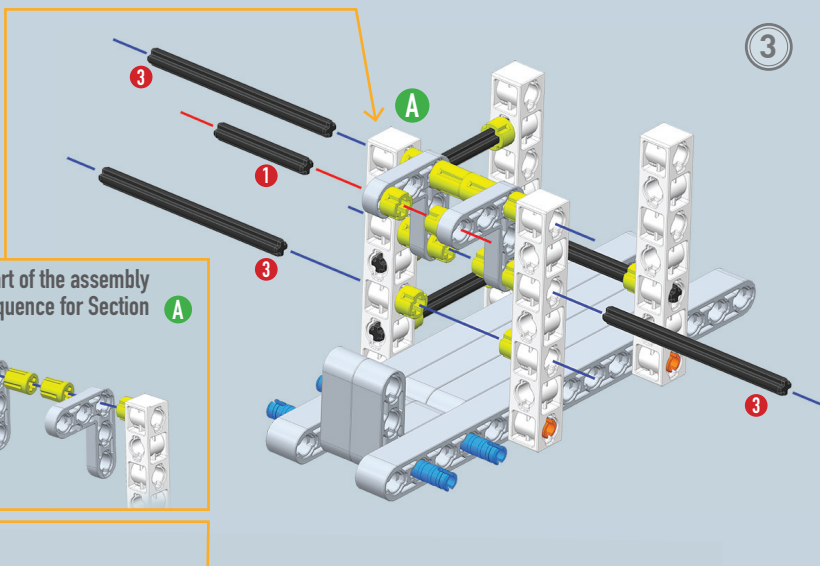

Start of the assembly sequence for Section **A**

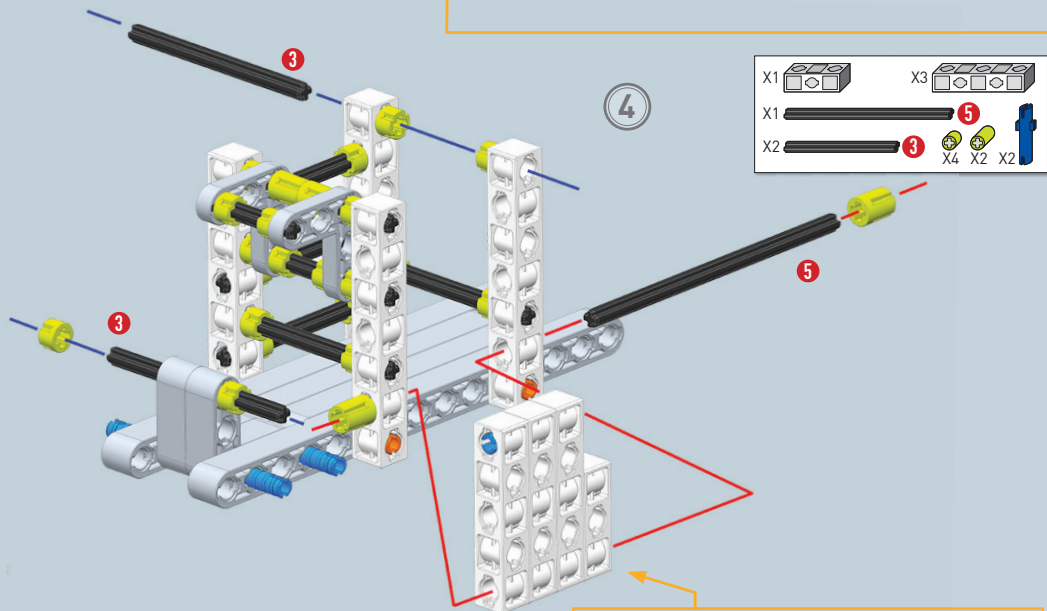
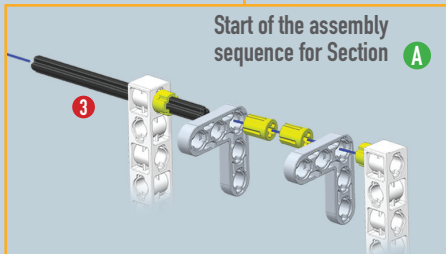

4

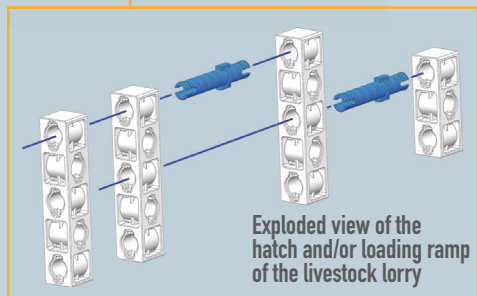
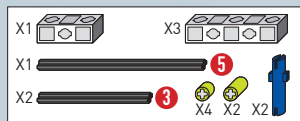

Exploded view of the hatch and/or loading ramp of the livestock lorry

5

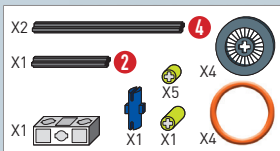
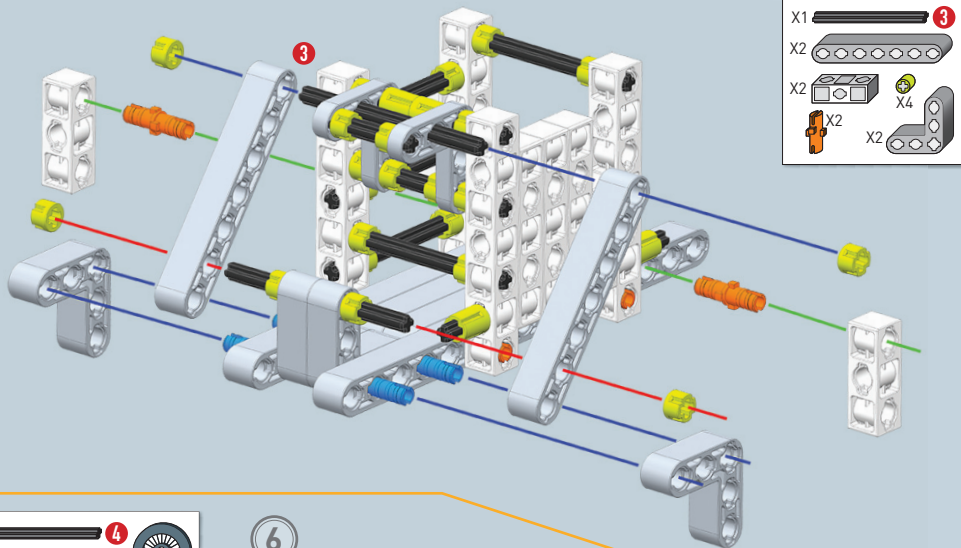

6

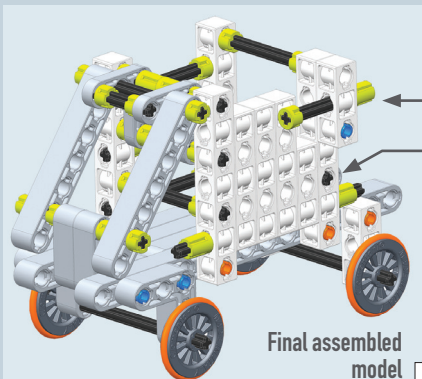
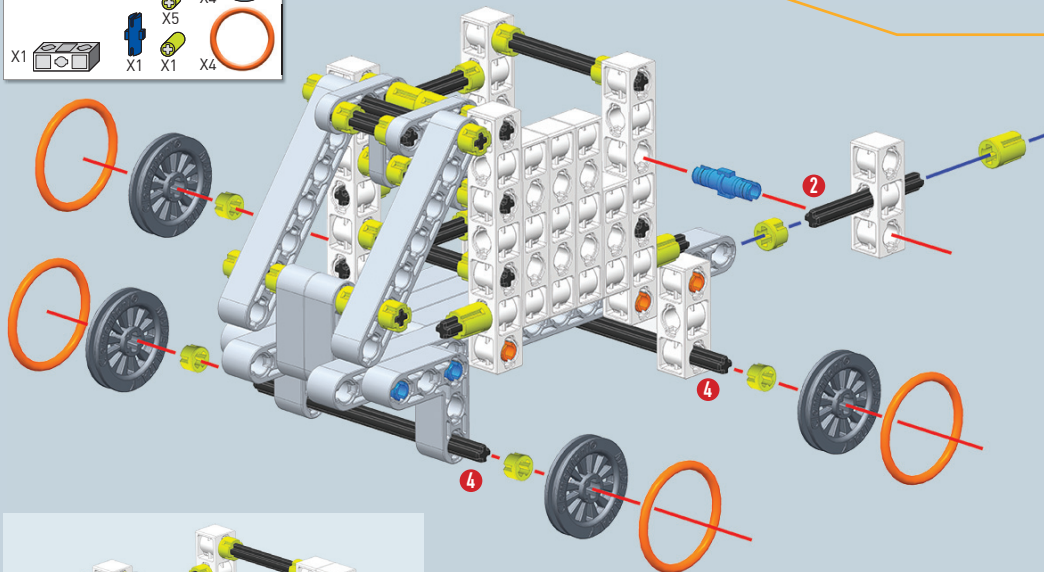

Final assembled model

← Rod for securing the hatch

← The hatch is hinged at the base which means it can be converted into a ramp for loading or unloading animals.



# 11 Play music with a Celtic harp

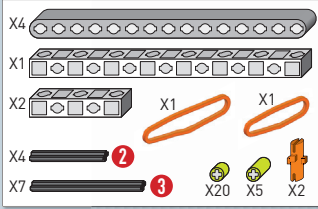

Note how four strings can be made from two elastic bands.

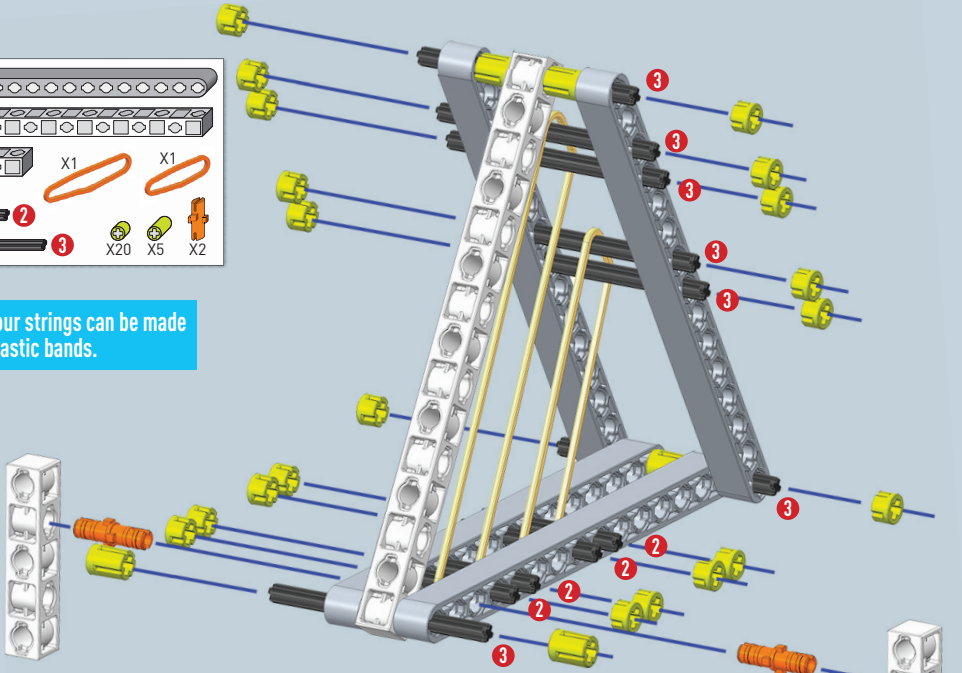

## Technical facts and curiosities

When you pluck a harp string with your fingers the air particles start to oscillate, generating sound vibrations in the air. On reaching your ear, these vibrations cross the tympanic membrane and from here travel to the brain, where they are perceived as sound. Sound also travels through liquids and solids. In air, sound travels at about 340 metres a second (m/s), in water it travels at 500 metres a second (m/s), in wood it travels an average of about 3,500 metres a second (m/s) and in iron it travels at over 5,000 metres a second (m/s). Sound does not travel in a vacuum or in space because there is no air.

• Pluck the strings in the order shown

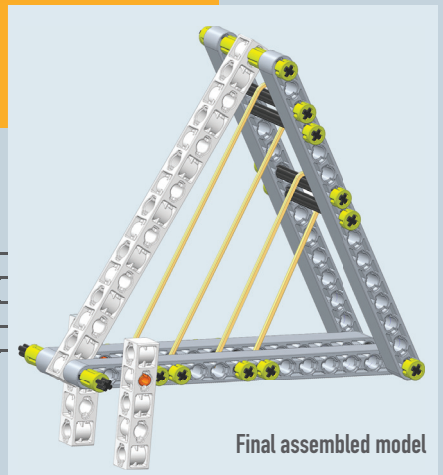

Final assembled model

# PARTS LIST



Double beam 15 holes 4 pcs



Double beam 11 holes 4 pcs



Double beam 9 holes 4 pcs



Double beam 7 holes 4 pcs



Double beam 5 holes 4 pcs



Double beam 3 holes 4 pcs

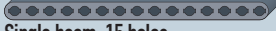

Single beam 15 holes 4 pcs



Single beam 13 holes 4 pcs



Single beam 9 holes 4 pcs



Single beam 7 holes 4 pcs



Single beam 5 holes 4 pcs



Single beam 3 holes 4 pcs



Angled beam (top) 4 pcs



Angled beam (bottom) 2 pcs



Rod 6 11.7 cm long 2 pcs

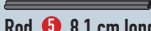

Rod 5 8.1 cm long 2 pcs

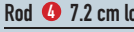

Rod 4 7.2 cm long 2 pcs

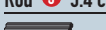

Rod 3 5.4 cm long 10 pcs



Rod 2 3.6 cm long 4 pcs



Rod 1 2.7 cm long 2 pcs



Beam with pegs 4 pcs



Beam with pins 4 pcs



Right angle gearbox 2 pcs



Short collar 24 pcs



Long collar 24 pcs



Short double peg 32 pcs



Short single peg 32 pcs



Long single peg 32 pcs



Cogwheel with 10 teeth 1 pc



Cogwheel with 18 teeth 5 pcs



Cogwheel with 26 teeth 1 pc



Cogwheel with 41 teeth 1 pc

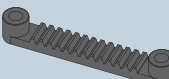

Toothed rod 1 pc



String (150 cm long) 1 pc



Steering wheel 1 pc



Spool 1 pc



Pulley 4 pcs



Hook 1 pcs



Crank 2 pcs



Elastic band 3 pcs



Small tyre (for pulley) 4 pcs



Electric motor 1 pc ~~1 pc~~

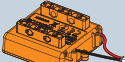

Battery compartment 1 pc ~~1 pc~~

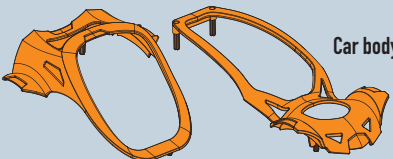

Car body 2 pcs



Large tyre 4 pcs



Wheel rim 4 pcs