

139,125

PATENT



SPECIFICATION

Application Date, Oct. 6, 1919. No. 24,306/19.

(Patent of Addition to No. 4183, Feb. 18, 1914.)

Complete Accepted, Feb. 26, 1920.

COMPLETE SPECIFICATION.

An Element for use in Building Constructional Toys or Models.

I, FRANK HORNBY, of Meccano Limited, Binns Road, Liverpool, Constructional Toy Manufacturer, do hereby declare the nature of this invention and in what manner the same is to be performed, to be particularly described and ascertained in and by the following statement:—

- 5 This invention relates to an improvement in or modification of the element for use in building constructional toys or models described in my prior Specification No. 4183—1914. In that invention the boss of the crank element had a plain bore which was adapted to be fitted over rods or the like and gripped thereon, or the bore of the boss might be used as a bearing. In the building
10 of constructional toys from interchangeable separate parts it is desirable that as many of the parts as possible used in the construction of such toys or models should be available for fulfilling several functions in order that the number of parts required in an outfit for building a series of models should be minimised as far as possible. The present invention is designed with that object.
- 15 According to this invention, the part or element consisting, as in my previous invention referred to, of a perforated strip web piece provided with a tubular boss, has the bore of such boss formed with an internal screw thread, so that a threaded rod or bar may be screwed therein, and in addition to the
20 axially threaded hole, one or two radial holes also internally threaded are made transversely to the axial hole, and where two such radial holes are provided they are disposed in line so that a threaded rod or bar may be screwed through both holes in alignment.

A crank element in accordance with this invention is illustrated in the accompanying drawings, Fig. 1 showing a face view of the crank element and Fig. 2 an
25 end view, Fig. 3 being a section analogous to Fig. 2, Fig. 4 shows the crank element bolted to a plate and the threaded bore engaged by a threaded rod, Fig. 5 being a view analogous to Fig. 4, but showing the crank boss engaged by a plain rod, and Fig. 6 illustrates how a pair of such crank elements may be bolted to a plate required say to be traversed by rotary movement of a screwed
30 rod.

In carrying out the invention, the strip web 1 of the crank is secured in any suitable manner to the boss 2, but preferably in the manner described in my prior specification and as shown in Fig. 3 by expanding the end 2a of the boss into an orifice formed in the web 1. The strip web is preferably provided with
35 two perforations, an inner hole 4 and an outer slot 5. The bore 3 of the boss is threaded internally so that it may be engaged by a screwed rod 6, and one

or two radial threaded holes 7, 8, are formed transversely across the boss. One of these holes may be used to receive a pinching screw 9 to enable the rod 6 to be gripped in the boss or, when such screw 9 is removed the aligned threaded holes 7, 8, are available to receive a threaded rod similar to the rod 6 passed completely through both holes. The web 1 of the crank element may be bolted 5 at 10 as shown in Figs. 4 and 5 to a plate 11 or other element, the rod 6 in Fig. 4 being shown axially threaded into the boss 2, the screw 9 being removed, while Fig. 5 shows the application of the element to receive a plain rod 12 in the screwed bore of the boss 2, the element then acting as the crank element of my prior specification and, if desired, the plain rod 12 may slidably engage 10 the threaded bore of the boss 2 or be gripped therein by the screw 9.

A crank element, the boss of which is internally threaded for engagement by a screwed rod, as described, is capable of a variety of uses in building up constructional toys from a number of separate parts, for instance, as shown in Fig. 6, such elements may be used where it is required that a platform or plate 15 such as 13 be traversed to and fro from the rod 6 which rotates, the webs 1 of the crank element being bolted to the flanges of the plate 3 and the screwed rod 6 engaging the threaded bore of the bosses of both cranks. If the rod be fixed against axial movement and rotated the platform 3 will be traversed in one direction or another according to the direction of rotation of the rod 6 to 20 the crank elements in this example as fixed nuts.

The element lends itself to very many similar uses in connection with the building of construction toys from outfits consisting of interchangeable parts.

Having now particularly described and ascertained the nature of my said invention and in what manner the same is to be performed, I declare that 25 what I claim is:—

1. An element for use in the building of constructional toys or models from interchangeable parts, comprising, a strip web or plate provided with an internally threaded tubular boss, the strip web of the element being perforated.

2. An element for use in the building of constructional toys or models from 30 interchangeable parts, comprising, a strip web or plate provided with an internally threaded tubular boss, the strip web of the element being perforated with an outer slot and an inner hole.

3. An element for use in the building of constructional toys or models from interchangeable parts, comprising, a strip web or plate provided with a tubular 35 boss having an axial threaded hole therein and one or more radial threaded holes, the strip web of the element being perforated.

4. The element for use in the building of constructional toys or models from interchangeable parts, substantially as described and shown in Figs. 1 to 6 40 inclusive of the accompanying drawings.

Dated this 25th day of September, 1919.

For the Applicant,

A. J. DAVIES,
Patent Agent,
37, Moorfields, Liverpool.

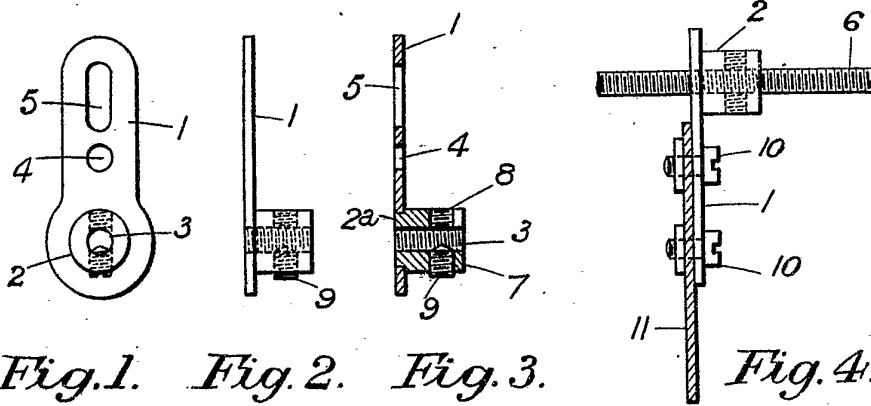

Fig. 1.

Fig. 2.

Fig. 3.

Fig. 4.

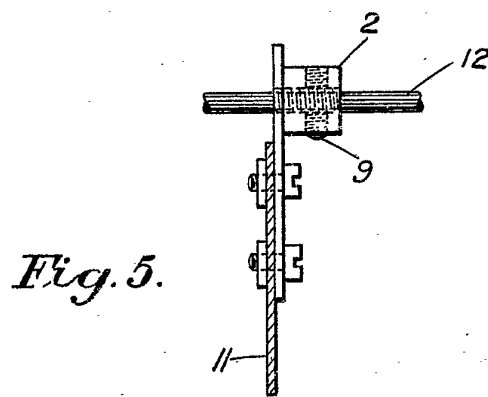

Fig. 5.

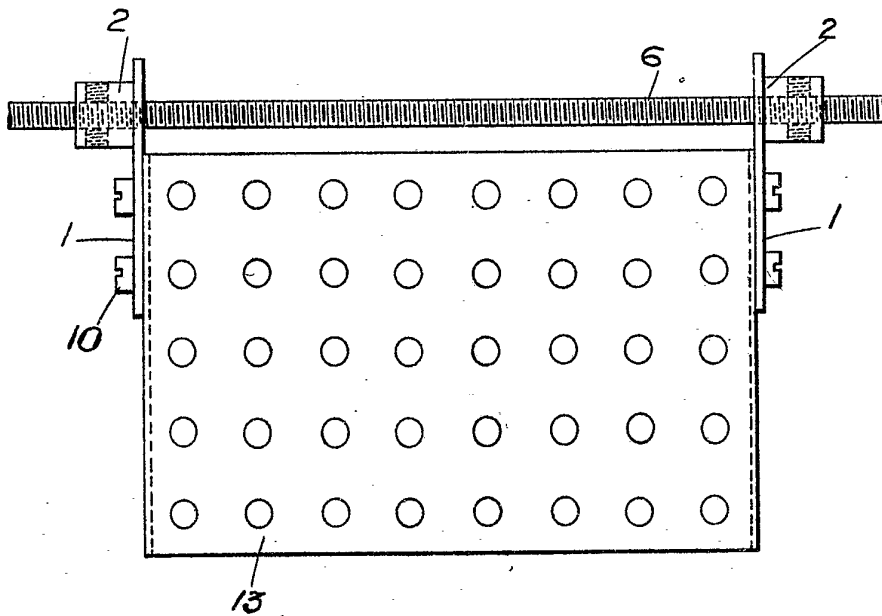

Fig. 6.